



TOWER DRYER

with
QuadraTouch Pro™
Dryer Control System



OWNER'S OPERATION MANUAL

Sukup Manufacturing Co.

1555 255th Street, Box 677

Sheffield, Iowa, USA 50475-0677

Phone: 641-892-4222

Fax: 641-892-4629

Website: www.sukup.com

E-mail: info@sukup.com



Thank you for purchasing Sukup equipment. At Sukup Manufacturing Co., we strive to provide our customers with the best products available. It's important to us that you get the best value for your money. That means producing top-quality products that will provide you with many years of satisfied ownership.

We back our products with experienced staff and the best customer service in the industry. Our dedicated employees have done their best to ensure that your Sukup equipment will meet your needs. With proper installation and use, it will serve you for many years.

If for some reason you experience difficulties with your Sukup equipment, your authorized Sukup dealer can provide you with the help you need. If you need assistance beyond what your dealer can provide, you can always contact your regional Sukup Distribution Center or our headquarters in Sheffield, Iowa, USA.

Thank you again for your purchase. We wish you many years of profitable, safe use of your Sukup equipment.

Steve, Emily, Matt,
Andy, Charles and
The Entire Sukup Family

Sukup Manufacturing Co.
Sheffield, Iowa, USA

Tower Dryer Owner's Operation Manual

This manual is comprised of several tabbed sections. The first provides warranty and safety information and identifies components of dryer. Others provide instructions for operation, troubleshooting and maintenance of dryer. Please read entire manual thoroughly before installation or operation. Check with dealer before each drying season for important updates.

Table of Contents

Section 1. Preliminary Information

- Warranty
- Safety Section
- Emergency Shutdown
- Component Identification

Section 2. Operation

- Introduction
- Start-up Preliminary Steps

Section 3. Maintenance

- Periodic Maintenance
- Component Maintenance

Section 4. Troubleshooting

- Quick-reference Troubleshooting
- Component Troubleshooting

Section 5. Software Manual

Section 6. Electrical Drawings

Section 7. Parts/Assemblies

Appendices A through K

- A. Specifications
- B. Electrical Requirements
- C. Drying Rate Tables
- D. Ground Rod Requirements
- E. Setting Unload System
- F. Adjusting Grain Flow Tube
- G. Altistart 22 Soft Start
- H. Altivar Variable Frequency Drive
- I. Burner Control Unit LME 69
- J. Optional Features

PLEASE NOTE: Information in this manual is property of Sukup Manufacturing Co., Sheffield, Iowa, USA, and is provided on condition that it will not be used in any way detrimental to the company's interests. Reproduction of contents is prohibited unless express written consent is given from Sukup Manufacturing Co.

Preliminary Information

Table of Contents

Warranty-----	1-2
Safety -----	1-3
Safety Decal Placement -----	1-10
Main Switch & Emergency Stop Switch Locations -----	1-11
Dryer Component Identification -----	1-12
Sensor/Switch Locations -----	1-12
Power Box Component Identification -----	1-14
Pipe Train Component Identification -----	1-18
Switches, Various Components-----	1-22
Touch-Screen Controller-----	1-28

<u>DATE</u>	<u>REVISION</u>	<u>PAGE</u>
12/28/2022	– Updated description of power distribution box -----	11
	Updated statements on inspecting wiring & limiting electromagnetic interference -----	14
	Added specifications for Models U1512 & U10030-----	15, 17, 19 & 20
	Added reference to updated statements on Page 14 -----	16



Sukup Manufacturing Co.
PO Box 677 Sheffield, IA USA 50475
Phone: 641-892-4222 Fax: 641-892-4629
E-mail: Info@sukup.com Visit us at: www.sukup.com

TOWER DRYER LIMITED WARRANTY

SUKUP MANUFACTURING CO. (Sukup) warrants to original retail purchaser that within time limits set forth, new equipment shall be free from defects in material and workmanship. A part will not be considered defective if it substantially fulfills performance specifications, such as cosmetic (appearance) issues that will not affect life of product. Should any part prove defective within warranty period, part will be replaced or repaired without charge F.O.B. Sukup Manufacturing Co., Sheffield, Iowa USA or Distribution Centers - Arcola, Illinois; Aurora, Nebraska; Cameron, Missouri; Defiance, Ohio; Jonesboro, Arkansas; Watertown, South Dakota. To claim warranty, a copy of original invoice is required, see reverse side.

THE FOREGOING LIMITED WARRANTY IS EXCLUSIVE AND IN LIEU OF ALL OTHER WARRANTIES OF MERCHANTABILITY, FITNESS FOR PARTICULAR PURPOSE AND OF ANY OTHER TYPE, WHETHER EXPRESS OR IMPLIED. Sukup neither assumes nor authorizes anyone to assume for it any other obligation or liability in connection with said part, and will not be liable for incidental or consequential damages. THE REMEDIES STATED HEREIN SHALL BE THE EXCLUSIVE REMEDIES AVAILABLE UNDER THIS LIMITED WARRANTY.

Sukup reserves the right to change specifications, add improvements or discontinue manufacture of any of its equipment without notice or obligation to purchasers of its equipment. This warranty gives you specific legal rights. You may also have other rights which vary according to state or province.

WARRANTY EXCLUSIONS - Labor, transportation, or any cost related to a service call is not provided by Sukup. This Limited Warranty does not apply to damage resulting from misuse, neglect, normal wear, accident or improper installation or maintenance. ITEMS NOT MANUFACTURED BY SUKUP (e.g., belts, motors) ARE COVERED UNDER WARRANTIES OF THEIR RESPECTIVE MANUFACTURERS AND ARE EXCLUDED FROM COVERAGE UNDER THE SUKUP WARRANTY. SUKUP MANUFACTURING CO. MAKES NO WARRANTY, EXPRESS OR IMPLIED, OF MERCHANTABILITY OR FITNESS FOR A PARTICULAR PURPOSE.

Upon taking delivery of product, purchaser (dealer and/or end user) assumes responsibility for proper storage of all materials. Proper storage includes dry, temperature and humidity controlled facilities that eliminate the potential of moisture, including condensation, from causing white rust and/or corrosion of any sort. Warranty does not extend to defects, damage or cosmetic (appearance) issues caused by improper storage or handling.

TOWER DRYER WARRANTY - Sukup warrants stick-built tower dryers for one year from date of purchase and modular tower dryers for two years from date of purchase.

An optional **FOUR-YEAR** (stick-built) or **THREE-YEAR** (modular) **LIMITED WARRANTY EXTENSION** may be purchased **only** at time of dryer purchase. Period of extended warranty begins on 13th month (stick-built) or 25th month (modular) after date of purchase and continues through 60th month from date of purchase. Dryer parts found to be defective during this period will be replaced or repaired, with the exception of motors (as excluded herein) or "wear parts" (any parts worn by high usage, such as rotors, bearings, burner components, moving parts, sensors, etc.). Extended limited warranty does not apply to labor, transportation, shipping or any cost related to a service call.

REPLACEMENT PARTS WARRANTY PERIOD - Sukup warrants replacement parts (e.g. belts, sensors, rotating contacts, gearmotors, switches) purchased from Sukup for one (1) full drying season following purchase.

ELECTRIC MOTOR WARRANTY - The manufacturers of electric motors warranty their motors through authorized service centers for a 2-year period from motor date code. Contact motor manufacturer for nearest location. If motor warranty is refused by a service center based upon date of manufacture, use the following procedure: Have motor repair shop fill out the warranty report form as if they were providing warranty service. State on report reason for refusal. Send report, motor nameplate, and proof of purchase date (invoice from Sukup and invoice for your customer) to Sukup. If electric motor warranty is not satisfactorily handled by motor service center, contact Sukup for assistance. Sukup will attempt to obtain warranty from motor manufacturer. Any credit obtained will be passed on. Warranty may also be obtained by returning motor to Sukup Manufacturing Co. or Distribution Centers with prior authorization. **NOTE:** Sukup will not be responsible for unauthorized motor replacement or repair. Labor for removal of motor from fan not included.

WARRANTY CERTIFICATION - Warranty registration card should be mailed within one month of product delivery to certify warranty coverage.

UNAPPROVED PARTS OR MODIFICATION - All obligations of Sukup under this warranty are terminated if unapproved parts are used or if equipment is modified or altered in any way not approved by Sukup.

Purchaser must adhere to applicable safety regulations and federal, state and local codes in the location, installation, and use of this product. Sukup assumes no responsibility for property damages or personal injuries.

2/14/18



Read manual before installing or using product. Failure to follow instructions and safety precautions in manual can result in death or serious injury. Keep manual in a safe location for future reference.



On safety decals and throughout this manual, this symbol and the signal words Danger, Warning, Caution and Notice draw your attention to important instructions regarding safety. They indicate potential hazards and levels of intensity.



DANGER indicates an imminently hazardous situation which, if not avoided, will result in death or serious injury.



WARNING indicates a potentially hazardous situation which, if not avoided, could result in death or serious injury.



CAUTION indicates a potentially hazardous situation which, if not avoided, may result in minor or moderate injury.



NOTICE alerts you to practices unrelated to personal injury, such as messages related to property damage.

IMPORTANT: To prevent death or serious injury to you or your family, it is essential that safety decals are clearly visible, in good condition, and applied to the appropriate equipment.

FOLLOW MANUAL & SAFETY DECAL MESSAGES

Observe safe operating practices. Carefully read this manual and all safety decals on your equipment. Safety decals must be kept in good condition. Replace missing or damaged safety decals free of charge by contacting Sukup Manufacturing Co. by mail at PO Box 677, Sheffield, Iowa USA 50475; by phone at 641-892-4222; or on our website, www.sukup.com.



Learn how to use controls and operate machine. Do not operate without safety shields in place. Worn or missing shields can be replaced free of charge by contacting Sukup Manufacturing Co.

Do not let anyone operate unit without thorough training of basic operating and safety procedures. Owners/operators need to know what specific requirements, precautions, and work hazards exist. It is their responsibility to inform anyone near equipment of hazards and safety precautions that need to be taken to avoid personal injury. Always keep children away from bins and vehicles with flowing grain.

Make no unauthorized modifications to machine. Modifications may endanger function and/or safety of unit. Keep unit well-maintained according to procedures in Maintenance section of this manual.

NOTICE: Do not dump polluting liquids, worn parts and maintenance waste into the environment. Dispose of all such materials as specified by applicable standards.



WARNING: PREVENT EXPLOSION OR FIRE

- Carefully review operator's manual
- Keep dryer clean inside and out, as fines may cause a fire
- Check for gas leaks by spraying soapy solution on piping and joints
- Run fan at least half a minute before starting heater
- NEVER start heater if you smell gas or hear a hissing sound
- NEVER run heater with inspection door open

Failure to heed these warnings could cause death or serious injury.



ANALYZE ARC FLASH/SHOCK HAZARD. Equipment containing switchboards, panelboards, industrial control panels, meter socket enclosures, and motor control centers is subject to National Electrical Code (NEC), National Fire Protection Association (NFPA), and Occupational Safety and Health Administration (OSHA) regulations. Installations must be analyzed for arc flash and shock hazard.

Additional requirements under these standards include:

- Facility needs to have written electrical safety program.*
- Equipment shall be FIELD MARKED with a label containing available incident energy and/or required Personal Protective Equipment (PPE) level.

This labeling requirement is employer's responsibility and not that of equipment manufacturer or installer.

- All persons working on or near affected equipment must be properly trained.
- Proper tools and equipment must be provided by installation operator or employer.

*NFPA 70E has numerous significant changes in 2012 edition. Be sure to update your facility's safety program.



USE PROPER LOCKOUT PROCEDURES. Facility management needs to proactively train employees to ensure use of proper lockout procedures while working on dryer. Management also needs to inspect this unit for any covers or guards not in proper place. It is everyone's responsibility to report any missing grates, guards, equipment failures or failures to lock out. Make certain that no cover is removed unless power is locked out.

NOTE: Refer to OSHA's typical minimal lockout procedures (29CFR 1910.147 App A).

Basic Safety Rules

1. Learn how to use controls and operate equipment.
2. Do not let anyone operate unit without thorough training of basic operating and safety procedures. **Always follow a proper lockout procedure.**
3. Periodically check all mechanical and electrical components. Keep unit in good working condition.
4. Handle equipment and parts with care. **Wear protective clothing** to avoid injury from sharp metal edges.
5. Wear Personal Protective Equipment (PPE) such as safety glasses, gloves, hardhat, steel-toe boots, ear protection and dust mask as required by local, state and national regulations.

Good housekeeping practices and correct safety procedures will help protect lives, jobs, property and profits.

Please contact Sukup Manufacturing Co. with any specific safety questions about dryer or its use!



To avoid electric shock or electrocution, all equipment must be properly wired and grounded according to electrical codes. Have unit wired by qualified electrician.

Have an electrician install a main power disconnect switch capable of being locked only in OFF position. Mark disconnect clearly as to equipment it operates. Always lock out main power disconnect switch whenever equipment is not in use.

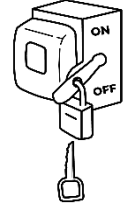

WARNING: When servicing equipment, never enter bin unless all power is locked out and another person is present. Always LOCK OUT all power and always check with voltage meter before servicing.

Failure to do so could result in death or serious injury.

NOTE: Refer to OSHA's typical minimal lockout procedures (29CFR 1910.147 App A) at www.osha.gov to establish a written plan for your work site.



WARNING: KEEP CLEAR OF ALL MOVING PARTS.

Keep people (ESPECIALLY YOUTH) away from equipment, particularly during operation.

Keep away from all moving parts. Keep all shields and screen guards in place. **SHUT OFF AND LOCK OUT** all power before servicing.

Failure to follow precautions above could result in death or serious injury.



WARNING: METAL IS SLIPPERY WHEN WET

Inspect ladder carefully before use. Never climb deteriorated, damaged or improperly assembled ladder components. Maintain secure hand and foothold when climbing. Never carry items while climbing. Use safety harness and safety line as required by safety regulations.

Failure to heed these precautions could result in death or serious injury.

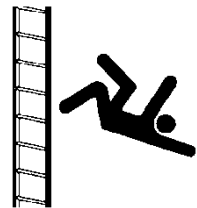

CAUTION: Metal edges are sharp. To avoid injury, wear protective clothing and handle equipment and parts with care. Failure to do so may result in minor or moderate injury.

PERSONAL PROTECTIVE EQUIPMENT

Owners/Operators are responsible for developing site-specific personal protective equipment standards.

These include, but are not limited to personal protective equipment for eyes, face, head, and extremities, as well as protective clothing and respiratory devices.

For a complete listing of OSHA's personal protective equipment standards go to www.osha.gov (29CFR 1910.132).

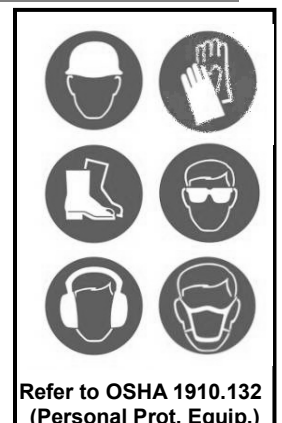

Refer to OSHA 1910.132 (Personal Prot. Equip.)

Grain Bin Safety

When entering a bin, owners/operators are responsible for following site-specific confined space entry procedures. OSHA's confined space entry procedures (29CFR 1910.146) can be found at www.osha.gov.

If you must enter bin for repair or maintenance:

- Use a safety harness, safety line and respirator
- Station another person outside of bin
- Avoid the center of the bin
- Wear appropriate personal protective equipment
- Keep clear of all augers and moving parts



DANGER: Never enter bin unless all power is locked out and another person is present.



**Rotating augers
can kill or
dismember!**

NEVER enter bin when augers are running!

When bin is nearly empty, sweep auger will travel at an increasingly fast speed. Keep away from sweep and sump augers to avoid entanglement.

Failure to follow these precautions will result in death or serious injury.

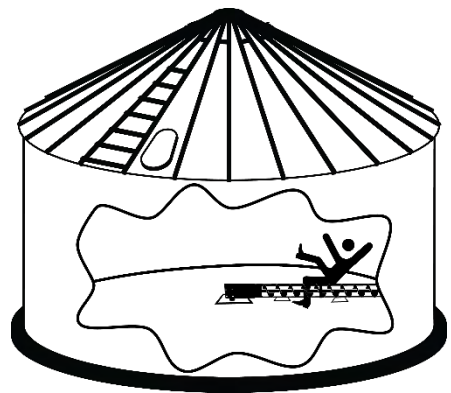

DANGER: Flowing grain may trap and suffocate. If you enter a bin of flowing grain you can be completely submerged in grain in about 8 seconds.

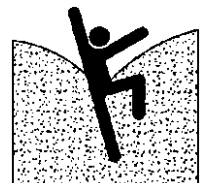

Failure to heed this warning will result in death or serious injury.

EMERGENCIES - KNOW WHAT TO DO

Have emergency numbers and written directions to work site readily available in case of emergency. An area to record emergency information is provided below.

Ambulance • Fire • Police: 9-1-1
Farm rescue team: _____
Local EMS team: _____
Address of work site: _____
Directions to work site: _____

Electrical Wire Clearances

Your local electric utility may be able to provide assistance in planning a safe environment for working around tower dryers and associated structures. State codes may vary regarding specific clearances for electrical lines around structures. Be certain your local electric utility is in accordance with your state's regulations. **To prevent overhead safety issues, bury electrical lines.**

The American National Standards Institute (ANSI) provides clearance envelopes for Grain Bins filled by permanently installed augers, conveyors or elevators in (ANSI) C2 2007 "National Electrical Safety Code," Rule 234, page 120.

NOTE: An electric utility company may refuse to provide electrical service to any tower dryer or grain bin built near an existing electric line that does not provide clearance required by ANSI and the National Electrical Safety Code.

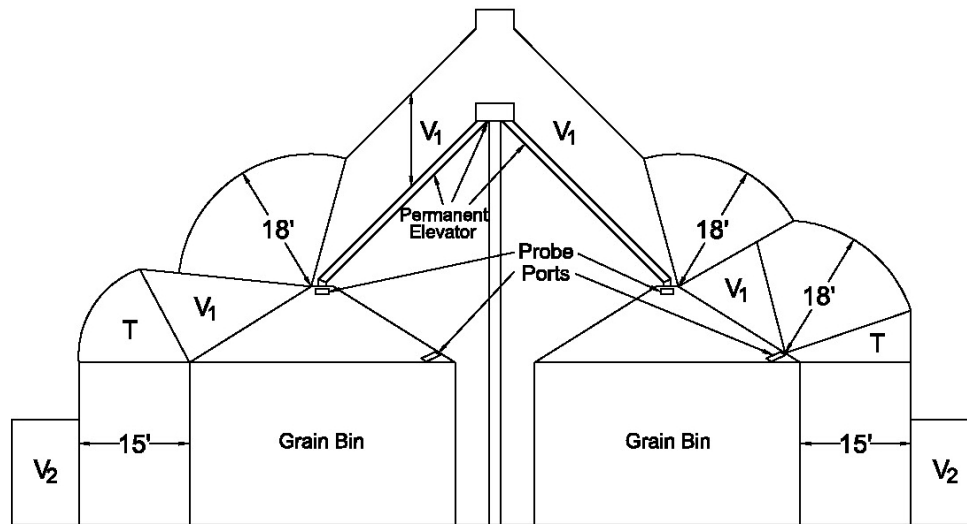

V_1 = Vertical clearance above a building required by Rule 234C (Table 234-1)

V_2 = Vertical clearance above land required by Rule 232

T = Transition clearance

Fig. 1 – Electrical wire clearances

To prevent death or serious injury to people involved in operation of this equipment, it is essential that these safety decals be mounted on dryer. Check that all are in place according to the decal placement drawing and are legible when dryer is installed.

IMPORTANT: If suggested locations are not clearly visible, place safety decals in a more suitable area. Never cover up existing safety decals.

Make sure location for decal is free from grease, oil and dirt. Remove backing from decal and place in proper position. Replace missing or damaged safety decals or shields free of charge by contacting Sukup Manufacturing Co. by mail at Box 677, Sheffield, Iowa 50475 USA; by phone at 641-892-4222; or by e-mail at info@sukup.com. Please specify number when ordering.

1. **Decal L0164 – WARNING:** Ladder safety – falling from heights hazard. Overall precautions for ladder safety.

WARNING

Failure to heed these warnings may cause serious injury or death.

- The working load limit of this ladder is 300 pounds. Do not overload.
- Inspect ladder carefully before use. Never climb deteriorated, damaged, or improperly assembled ladder components.
- Never use ladder if you are physically impaired.
- Never carry items while climbing.
- Always have another person present while climbing.
- Use safety harness and safety line as required.
- Metal is slippery when wet. Always maintain a firm grip and wear slip-resistant shoes when climbing.
- Always face ladder when using it.
- Never apply external load. Never push or pull anything while on ladder.

Sukup Mfg Company
Sheffield, IA USA 50475
L0164

2. **Decal L0258A – DANGER:** Do not enter this bin! Keep clear of all augers.

DANGER

Rotating fighting will kill or dismember. Flowing material will trap and suffocate. Crusted material will collapse and suffocate.

**DO NOT ENTER this bin!
Keep clear of all augers.**

If you must enter the bin:

- Shut off and lock out all power.
- Use a safety harness and safety line.
- Station another person outside the bin.
- Avoid the center of the bin.
- Wear proper breathing equipment or respirator.
- Follow applicable safety regulations.

Failure to heed these warnings will result in serious injury or death.

L0258A-08 Sukup Manufacturing Company, Sheffield, IA USA 50475

3. **Decal L0520 – CAUTION:** Failure to keep unit clean may cause fire and serious injury or death.

CAUTION

KEEP DRYER CLEAN!

- Do not allow fines to accumulate inside or outside dryer.
- Clean daily.
- Open lower slide gate at rear to blow fines out of dryer (see manual for cleaning instructions).
- Protect eyes from blown material.

Failure to keep unit clean may cause a fire and possible personal injury.

L0520-16 Sukup Manufacturing Co. Sheffield, IA USA 50475

4. **Decal L0237 – WARNING:** To prevent serious injury or death.

WARNING

TO PREVENT SERIOUS INJURY OR DEATH

Look out all power and have another person present before entering!

Door interlock switch is designed to shut off power to system if door is opened completely. For the safety of you, your family and workers, make sure that this switch has been installed and working properly (see owner's manual).

- NEVER disconnect key from chain or chain from door.
- DO NOT pull door open to disconnect switch. ALWAYS remove key manually.
- NEVER insert key into switch when someone is inside.
- INSTRUCT users on the safe use of the equipment.
- NEVER DEFEAT THE PURPOSE OF THIS SWITCH - Any fool can bypass a safety switch. don't be a fool.

L0237-07 SUKUP MANUFACTURING COMPANY SHEFFIELD, IA 50475

5. **Decal L0165 – WARNING:** Disconnect Electricity; Bleed gas; etc.



7. **Decal L0281 – WARNING:** To avoid serious injury or death.



6. **Decal L0284 – WARNING:** Keep away from all moving parts.



TOWER DRYER SAFETY (DECAL PACKET- U99999)

Safety decals should be mounted on dryer as shown on this page.

WARNING

Failure to heed these warnings may cause serious injury or death.

- The working load limit of this ladder is 300 pounds. Do not overload.
- Inspect ladder carefully before use. Never climb, deteriorated, damaged, or improperly assembled ladder components.
- Never use ladder if you are physically impaired.
- Never carry items while climbing.
- Always have another person present while climbing.
- Use safety harness and safety line as required.
- Metal is slippery when wet. Always maintain a firm grip and wear slip-resistant shoes when climbing.
- Always face ladder when using it.
- Never apply external load. Never push or pull anything while on ladder.

Sukup Mfg Company
Sheffield, IA USA 50475
L0164

WARNING

L0165

TO PREVENT SERIOUS INJURY OR DEATH:

Lock out all power and have another person present before entering. This machine is not designed to be entered unless it is stopped completely. For the safety of you, your family and workers, make sure that this switch has been installed and working properly (see owner's manual).

- NEVER dismount key from chain or chain from floor.
- DO NOT pull door open to disconnect switch. ALWAYS remove key manually.
- NEVER insert any key switch when someone is inside.
- RETRACT lines to the safe use of the equipment.
- NEVER DEFEAT THE PURPOSE OF THIS SWITCH - Any foot can bypass a safety switch. DON'T DO IT!

Replacement safety shields and decals are available free of charge.
L0281-02 Sukup Manufacturing Company Sheffield, IA USA 50475

WARNING

L0237

TO AVOID SERIOUS INJURY OR DEATH:

- Read operator's manual before operating & follow all precautions.
- Keep shields and decals in place.
- Keep clear of all moving parts.
- Allow no children or unqualified persons to operate equipment.
- Know how to shut off power quickly.
- Keep people (especially children) away from unit at all times.
- Lock out all power and have another person present when servicing unit.

Replacement safety shields and decals are available free of charge.
L0281-02 Sukup Manufacturing Company Sheffield, IA USA 50475

CAUTION

L0164

KEEP DRYER CLEAN!

- Do not allow fines to accumulate inside or outside dryer.
- Clean daily.
- Open lower slide gate at rear to blow fines out of dryer (see manual for cleaning instructions).
- Protect eyes from blown material. Failure to keep unit clean may cause a fire and serious injury or death.

0202 - 10000-0000-00000000-00000000-00000000

DANGER

L0520

DO NOT ENTER this bin!
Keep clear of all augers.

If you must enter the bin:

- Shut off and lock out all power.
- Use a safety harness and safety line.
- Station another person outside the bin.
- Avoid the center of the bin.
- Wear proper breathing equipment or respirator.
- Follow applicable safety regulations.

Failure to heed these warnings will result in serious injury or death.

0208-00 Sukup Manufacturing Company Sheffield, IA USA 50475

WARNING

L0281

KEEP AWAY FROM ALL MOVING PARTS

Keep all shields in place. Lock out all power before servicing.

FAILURE TO DO SO MAY CAUSE SERIOUS INJURY OR DEATH

L0284-14 Sukup Manufacturing Co., Sheffield, IA USA 50475

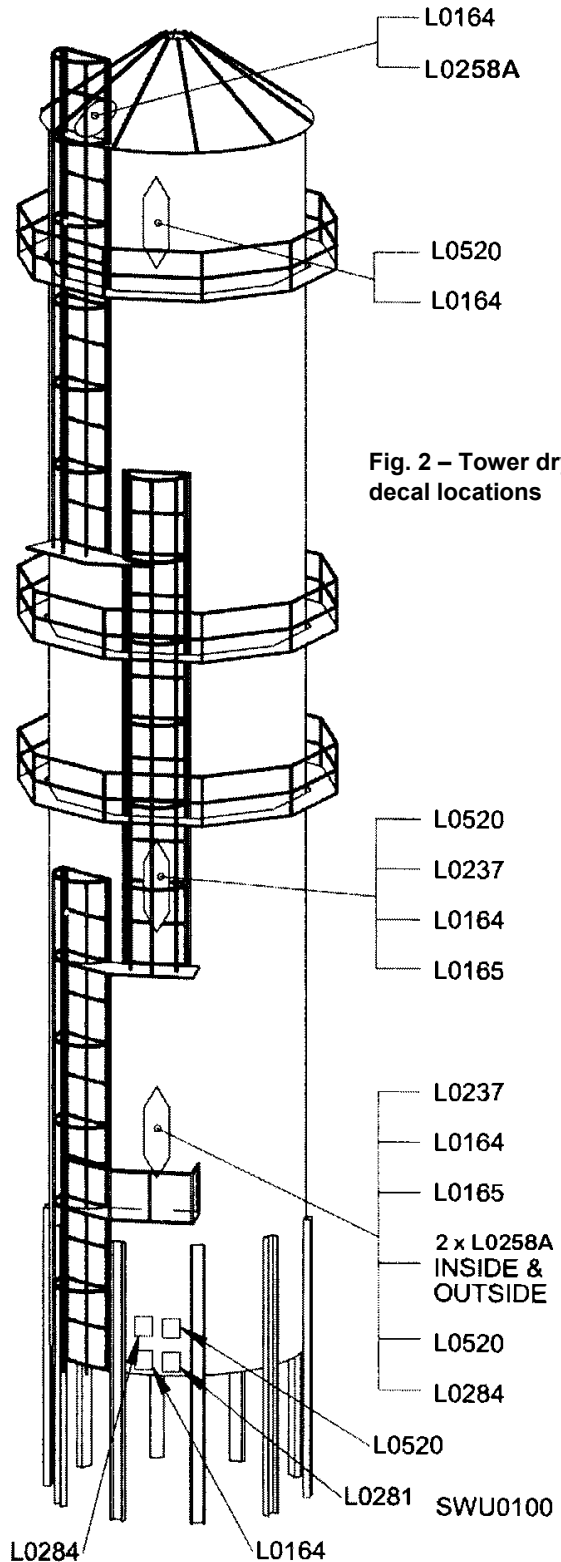
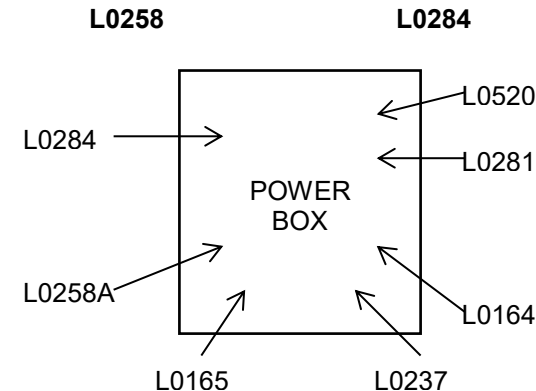

Fig. 2 – Tower dryer decal locations

Main Switch & Emergency Stop Switch Locations



Image 1 – Power distribution box

Power distribution box contains all main power distribution components, with higher voltage ($\geq 110V$) on right and lower voltage on left. Door handles secure doors and can be locked. Main Disconnect switch prevents opening of power box while power is present in system.

Image 1 shows power box on a one-fan dryer. Box for three-fan dryer is different, with gray exterior and larger black handles. Main Disconnect switch is at right on front of box.



WARNING: High voltage is still present on bottom terminals of main switch in power distribution box even if Main Disconnect switch is in “Off” position. To remove this voltage from power box, shut off main breaker ahead of dryer. Failure to follow this procedure could cause electrocution or shock, resulting in death or serious injury.



Image 2 – Main Disconnect switch

Image 2 shows Main Disconnect in “Off” position. Power is not present in system except as noted in warning above.

IMPORTANT: Turn switch off when dryer is not in use. This will cut power to programmable logic controller (PLC) and other components, protecting them from potential damage in case of a power surge.

NOTE: If outside air is below 32°F, turn switch on 15-20 minutes before use to warm up burner valves.



Image 3 – System Control & Emergency Stop switches

Emergency Stop switch is located on side of power distribution box. See Image 3. During operation, switch is pulled out and red knob is illuminated. Pressing Emergency Stop switch or switching Main Disconnect to “Off” position will shut off power to control system. Power will still be present inside main power box as noted in warning above.

Turn System Control switch to QuadraTouch Pro to run dryer. Turning to “Off” position will shut down power to control system. Power will still be present inside main power box as noted in warning above.

Sensor/Switch Locations

See Fig. 3 and Table 1 to identify tower dryer sensor/switch locations.

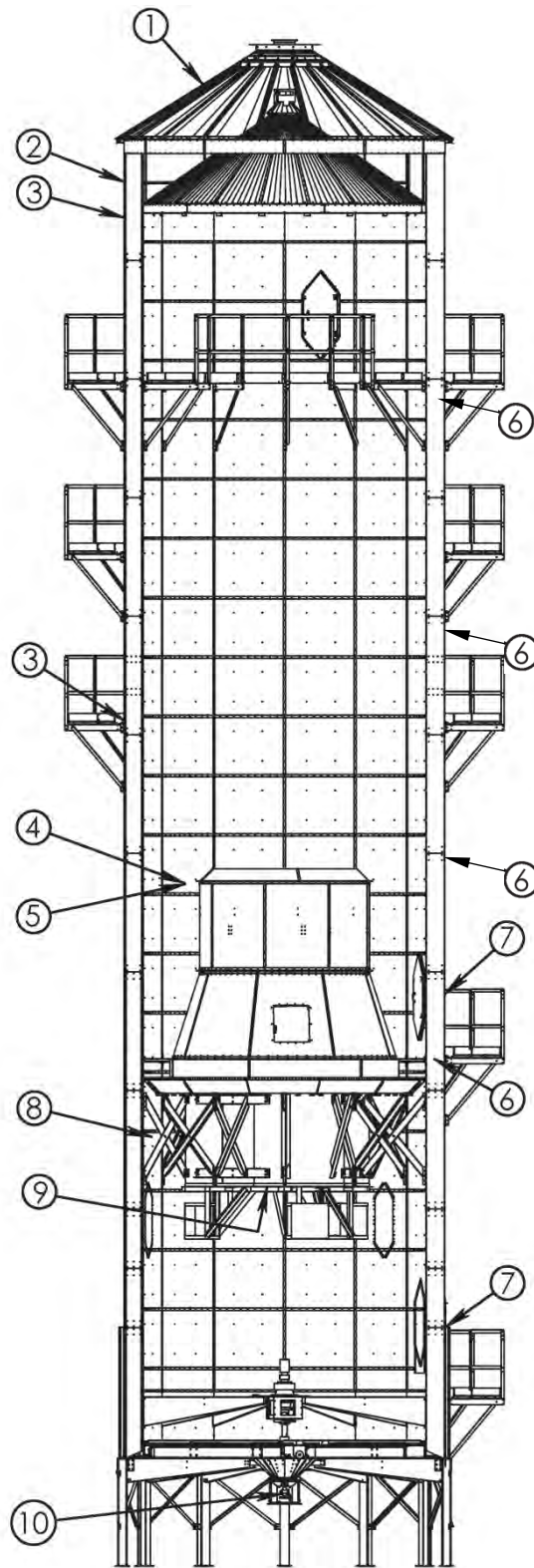

Fig. 3 – Tower dryer sensor/switch locations

Component Identification

ITEM #	PART #	DESCRIPTION	QTY.	LOCATION
1	J56701	Rotary Fill Switch	1	On roof, approximately 48" up from eave. (Mounting near stairs simplifies future maintenance.)
2	T6045S	Incoming Moisture Sensor	1	Mounting near ladder simplifies future maintenance
3*	Dryer Dia. 12': J4533 (24') 18': J4534 (28') 24': J17287 (40')	Upper Column Over-Temp Sensor All trip at 240°F	2	Top of first perforated sheet (below first two solid sheets)
		Middle Column Over-Temp Sensor. All trip at 240°F	2	On first perforated sheet below grain exchangers. If platform is in same location, mount sensor above toe-kick plate.
4*	Dryer Dia. 12': J6796 (24') 18': J6796 (24') 24': J67961 (28')	Plenum Over-Temp Switch. All trip at 325°F	2	Inside plenum/heat chamber, 1 ft. below top of burner cylinder. It can share holding clip with plenum RTD (Resistance Temperature Detector). To prevent large bends in copper tube, route it around top of door. This aids in future switch replacement.
5	J5648 (28')	Plenum RTD Sensor	1	Inside plenum/heat chamber, 1 ft. below top of burner cylinder (can share holding clip with Plenum Over-Temp Sensor).
6	TM91320	Single-Point Grain Column RTD Sensor	4	See Assembly Instructions L1987 sent w/ sensors.
7	J4487	Access Door Switches	2	1 – In door leading into cooling chamber 1 – In door for heating chamber
8*	Dryer Dia. 12': J4532 (16') 18': J4533 (24') 24': J17287 (40')	Lower Column Over-Temp Sensor All trip at 240°F	2	Inside dryer in cool chamber, 2-3 ft. below divide
9	J5860	Blower Air Switch	1, 3 or 4	Tube is at inlet of blower. Switch is in power box.
10	T6045S	Discharge Moisture Sensor	1	At discharge of dryer

* Sensors come in two sections, with length depending on diameter of dryer

Table 1 – Sensor/switch locations

Power Box Component Identification

Image 4 identifies major components of power box for a one-fan tower dryer.

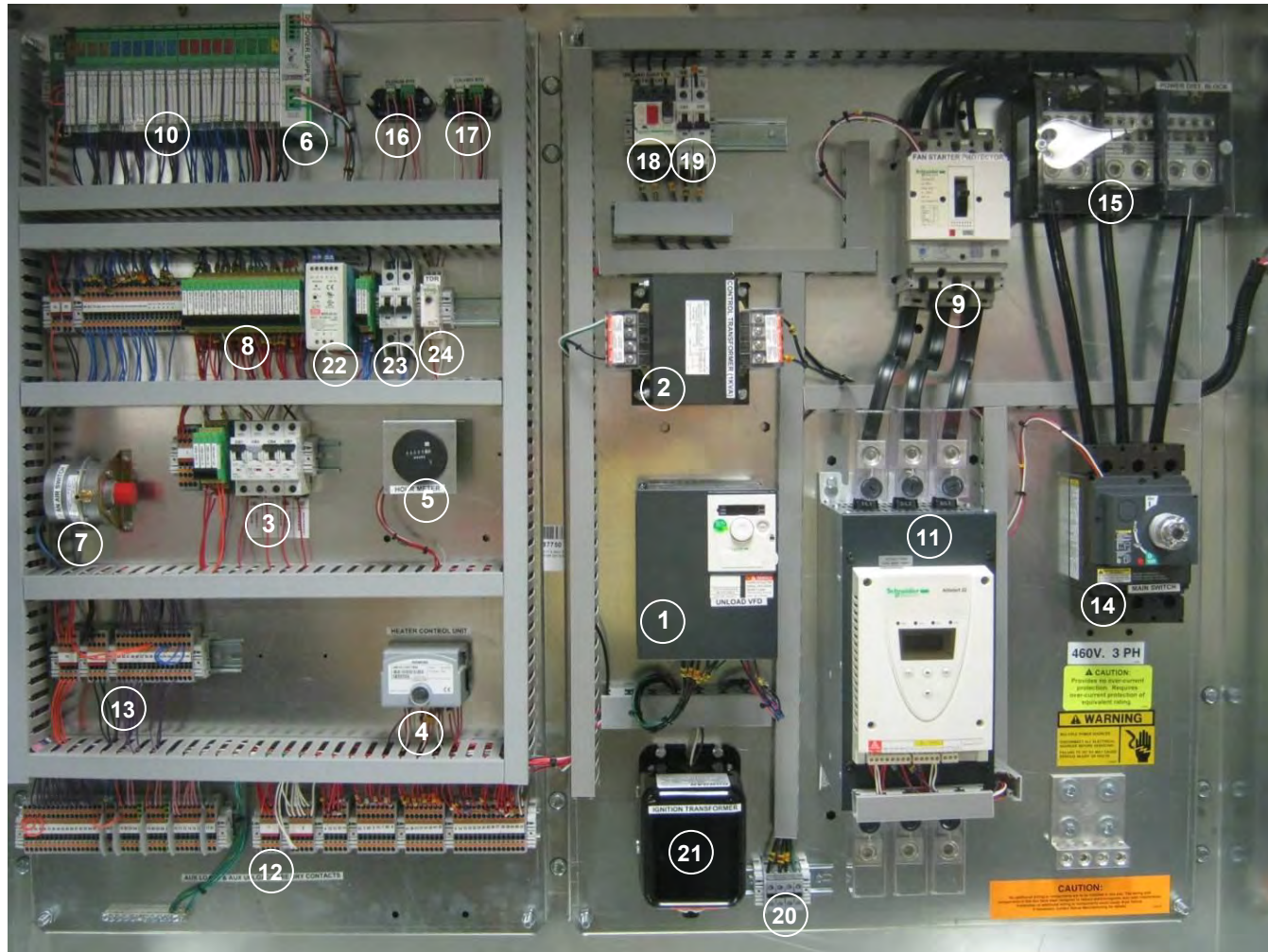

Image 4 – Power box components for single-fan tower dryer (Locations of some components may be different)

- | | |
|---|---|
| 1. Variable frequency drive | 13. DC feed-through terminals |
| 2. Control transformer | 14. Main switch |
| 3. Control/heater circuit breakers | 15. Power distribution block |
| 4. Burner control unit | 16. Column RTD transmitter |
| 5. Hour meter | 17. Plenum RTD transmitter |
| 6. 28V power supply | 18. Unload rotor starter protector |
| 7. Blower air switch | 19. Control transformer circuit breaker |
| 8. 28VDC/110VAC relays | 20. Unload rotor connections |
| 9. Blower starter protector | 21. Ignition transmitter |
| 10. Programmable logic control (PLC) | 22. Discharge gate actuator power supply |
| 11. Soft start w/ built-in bypass contactor | 23. Discharge gate actuator circuit breaker |
| 12. AC feed-through terminals | 24. Burner control time delay relay |

IMPORTANT: During initial setup or after relocation of dryer, ALL main power box wiring connections should be inspected. Wires are tightened at factory, but connections should be checked after transport and retightened as needed.

NOTICE: Low-voltage components (left side) are separated from high-voltage (right side) in power box to minimize electromagnetic interference on left side. Always maintain high/low voltage and AC/DC separation and practice good wire maintenance.

Component Identification

Table 2 shows part numbers of components in main power box for a single-fan tower dryer.

ITEM #	DESCRIPTION	SUKUP PART #	
		208/230V	460V
1	Variable frequency drive	J6848	J6851
2	Control transformer	J6485	
3	Control/heater circuit breakers	J48189, J48190, J48191, J48194 all used in each unit.	
4	Burner control unit	J5713	
5	Hour meter	J4766	
6	28V power supply	J8729	
7	Blower air switch	J5860	
8	28VDC/110VAC relays	J8727/28VDC J8728/110VAC	
9	Blower starter protector	See Table 3	
10	Programmable logic control (PLC)	J8700	
11	Soft start w/ built-in bypass contactor	See Table 3	
12	AC and DC feed-through terminals	J6915	
13			
14	Main switch	See Table 3	
15	Power distribution block	J6697	
16	Column RTD transmitter	U17018	
17	Plenum RTD transmitter	U17028	
18	Unload rotor starter protector	J5236	J5233
19	Control transformer circuit breaker	J48189	
20	Unload rotor connections	J6907	
21	Ignition transmitter	J5710	
22	Discharge gate actuator power supply	J8729	
23	Discharge gate actuator circuit breaker	J48191	
24	Burner control time delay relay	J5614	

Table 2 – Component numbers, single-fan dryer power box

Table 3 shows part numbers of soft start, blower starter protector and main switch, depending on fan motor HP and voltage.

DRYER MODEL	FAN MOTOR HP	MOTOR PART #	SOFT START			BLOWER STARTER PROTECTOR			MAIN SWITCH		
			208/230V	460V	575V	208/230V	460V	575V	208/230V	460V	575V
U1512	75	H7505W	J6872	J6868	---	J5241	J5241	---	J5214	J52121	---
U1812	75	H7505	J6872	J6868	J6867	J52411	J5241	J5235	J5214	J52121	J52121
U2012	100	H7510	J6873	J6870	J6869	J48153	J5241	J5241	J5214	J52121	J52121
U2412	100	H7510	J6873	J6870	J6869	J48153	J5241	J5241	J5214	J52121	J52121
U2712	125	H5711	---	J6871	---	---	J52411	---	---	J52121	---

Table 3 – Soft start, blower starter protector and main switch part numbers, single-fan dryer power box

Illustration below shows part numbers of “slices” in PLC. Slices are same for one-fan and three-fan dryers. There are six blue slices, five red, three green and one yellow. All are individual slices except for J8702 and J87031, each of which are four-slice units.

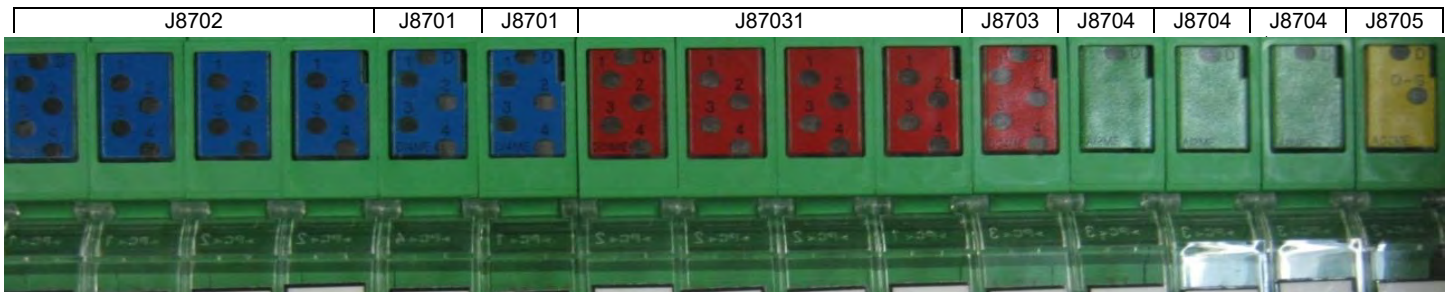

Component Identification

Image 5 identifies major components of power box for a three-fan tower dryer.

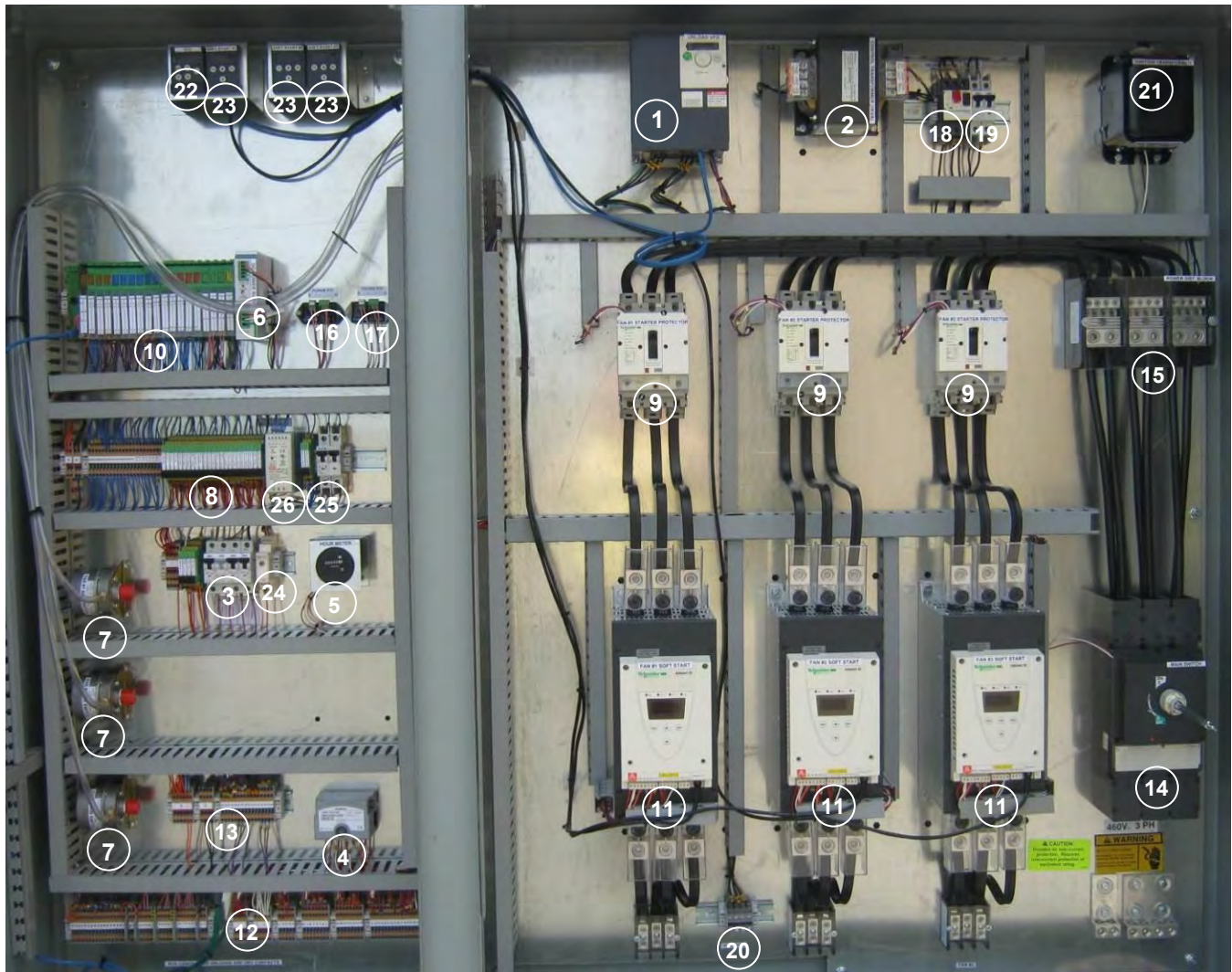

Image 5 – Power box components for three-fan tower dryer (Locations of some components may be different)

- | | |
|---|---|
| 1. Variable frequency drive | 14. Main switch |
| 2. Control transformer | 15. Power distribution block |
| 3. Control/heater circuit breakers | 16. Column RTD transmitter |
| 4. Burner control unit | 17. Plenum RTD transmitter |
| 5. Hour meter | 18. Unload rotor starter protector |
| 6. 28V power supply | 19. Control transformer circuit breaker |
| 7. Blower air switch | 20. Unload rotor connections |
| 8. 28VDC/110VAC relays | 21. Ignition transmitter |
| 9. Blower starter protector | 22. Variable frequency drive remote display |
| 10. Programmable logic control (PLC) | 23. Soft start remote display |
| 11. Soft start w/ built-in bypass contactor | 24. Burner control time delay relay |
| 12. AC feed-through terminals | 25. Discharge gate actuator circuit breaker |
| 13. DC feed-through terminals | 26. Discharge gate actuator power supply |

See Page 1-14 statements on inspecting wiring & limiting electromagnetic interference.

Component Identification

Table 4 shows part numbers of components in main power box for a three-fan tower dryer.

REF #	DESCRIPTION	SUKUP PART #	
		208/230V	460V
1	VARIABLE FREQUENCY DRIVE	J6848	J6851
2	CONTROL TRANSFORMER	J6485	
3	CONTROL/HEATER CIRCUIT BREAKERS	J48189, J48190, J48191, J48194 ALL USED IN EACH UNIT.	
4	BURNER CONTROL UNIT	J5713	
5	HOUR METER	J4766	
6	28V POWER SUPPLY	J8729	
7	BLOWER AIR SWITCH	J5860	
8	28VDC/110VAC RELAYS	J8727/28VDC J8728/110VAC	
9	BLOWER STARTER PROTECTOR	SEE TABLE 5	
10	PROGRAMMABLE LOGIC CONTROL (PLC)	J8700	
11	SOFT START W/ BUILT-IN BYPASS CONTACTOR	SEE TABLE 5	
12	AC AND DC FEED-THROUGH TERMINALS	J6915	
13			
14	MAIN SWITCH	SEE TABLE 5.	
15	POWER DISTRIBUTION BLOCK	J6697	
16	COLUMN RTD TRANSMITTER	U17018	
17	PLENUM RTD TRANSMITTER	U17028	
18	UNLOAD ROTOR STARTER PROTECTOR	J5236 FOR 18'	J5234 FOR 18'; J5236 FOR 24'
19	CONTROL TRANSFORMER CIRCUIT BREAKER	J48189	
20	UNLOAD ROTOR CONNECTIONS	J6907	
21	IGNITION TRANSMITTER	J5710	
22	VARIABLE FREQUENCY DRIVE REMOTE DISPLAY	J67801	
23	SOFT START REMOTE DISPLAY	J67803	
24	BURNER CONTROL TIME DELAY RELAY	J5614	
25	DISCHARGE GATE ACTUATOR CIRCUIT BREAKER	J48191	
26	DISCHARGE GATE ACTUATOR POWER SUPPLY	J8729	

Table 4 – Component numbers for three-fan dryer power box

Tables 5 and 6 show part numbers of soft start, blower starter protector and main switch, depending on fan motor HP and voltage.

DRYER MODEL	FAN MOTOR HP	MOTOR PART #	SOFT START			BLOWER STARTER PROTECTOR			MAIN SWITCH		
			208/230V	460V	575V	208/230V	460V	575V	208/230V	460V	575V
U3018	50	H7210B	J6870	J6866	---	J5241	J5235	---	J52121	J52121	J52121
U3518	60	H7260B	J6871	J6868	J6866	J52411	J5235	J5233	J52143	J5214	J5214
U4018	75	H7505W	J6872	J6868	J6867	J52411	J5241	J5235	J5214	J52121	J52121
U4718	75	H7505W	J6872	J6868	J6867	J52411	J5241	J5235	J5214	J52121	J52121
U5024	100	H7510W	J6873	J6870	J6869	J48153	J5241	J5241	J5214	J52121	J52121
U6024	100	H7510W	J6873	J6870	J6869	J48153	J5241	J5241	J5214	J52121	J52121
U7024	125	H7511W	---	J6871	---	---	J5241	---	---	J52143	---

Table 5 – Soft start, blower starter protector & main switch part numbers for three-fan dryer power box

See illustration on Page 1-15 for identification of “slices” in PLC.

DRYER MODEL	FAN MOTOR HP	MOTOR PART #	SOFT START	BLOWER STARTER PROTECTOR	MAIN SWITCH
			460V	460V	460V
U10030	125	H7511W	J6871	J5241	J67699

Table 6 – Soft start, blower starter protector & main switch part numbers for four-fan dryer power box

Tower Dryer Pipe Train Component Identification

Image 6 identifies pipe train components for a propane-fueled stick-built tower dryer.



WARNING: Check pipe train before each use to ensure components are properly connected and in good working order. Fuel leak could result in fire or explosion causing death or serious injury.

See Tables 7-10 for identification of pipe train part numbers for domestic stick-built tower dryers.

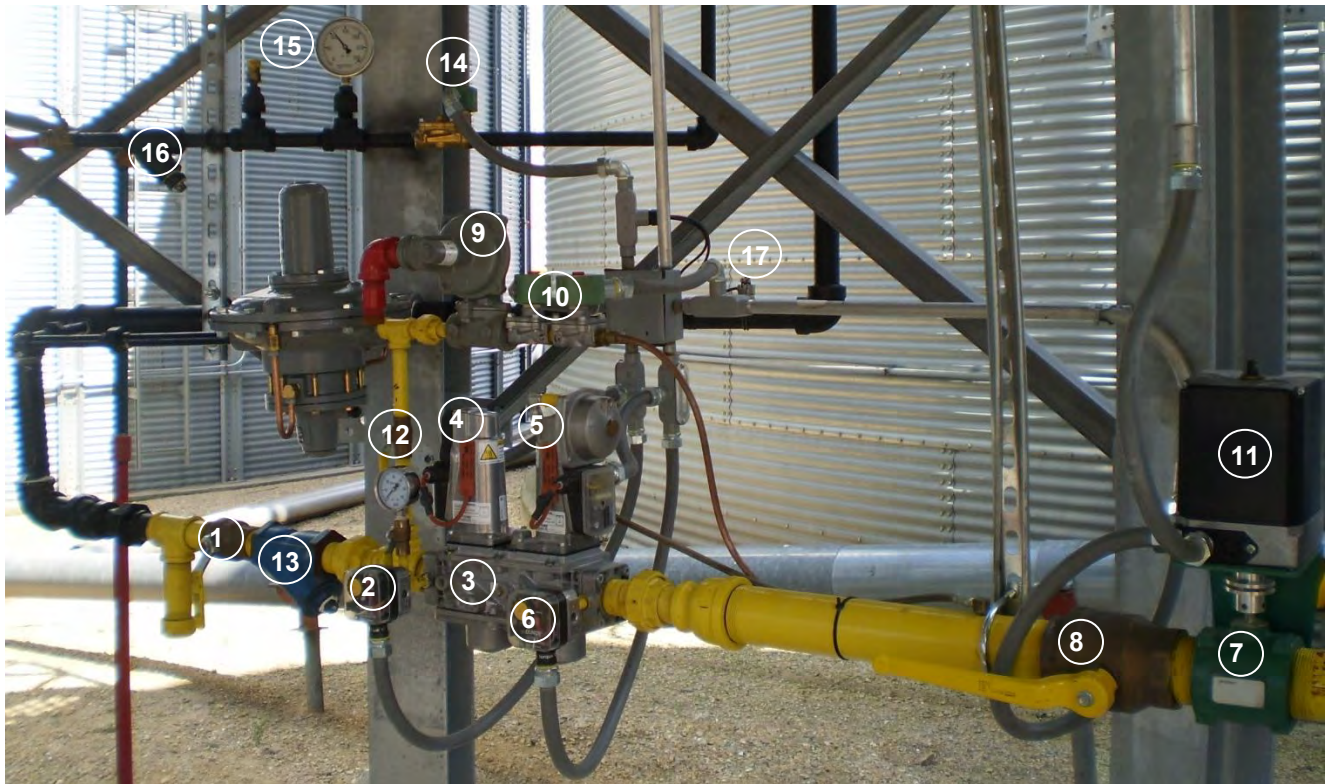

Image 6 – Stick-built tower dryer pipe train components

Siemens Pipe Train Part Numbers for Domestic Stick-Built Tower Dryers

NATURAL GAS

	ITEM #	1		2	3		4	5	6	7		8		9
DRYER MODEL	SIEMENS PIPE TRAIN	BALL VLV.	BALL SIZE	LOW PRESS. SWITCH	GAS VLV.	VLV. SIZE	ACTUATOR	ACT. & REG.	HIGH PRESS. SWITCH	BUTTERFLY VLV.	VLV. SIZE	BALL VLV.	BALL SIZE	1/2" PILOT REG.
U1512	J6336	J6087	1-1/2"	J4428	J6237	1-1/2"	J62407	J62403	J4428	J61311	2-1/2"	J6045	2-1/2"	J6164
U1812	J6337	J6088	2"	J4428	J6238	2"	J62407	J62403	J4428	J61321	3"	J6093	3"	J6164
U2012	J6337	J6088	2"	J4428	J6238	2"	J62407	J62403	J4428	J61321	3"	J6093	3"	J6164
U2412	J6337	J6088	2"	J4428	J6238	2"	J62407	J62403	J4428	J61321	3"	J6093	3"	J6164
U2712	J6337	J6088	2"	J4428	J6238	2"	J62407	J62403	J4428	J61321	3"	J6093	3"	J6164
U3018	J6339	J6045	2-1/2"	J4428	J62385	2-1/2"	J62407	J62403	J4428	J61651	4"	J6096	4"	J6164
U3518	J6339	J6045	2-1/2"	J4428	J62385	2-1/2"	J62407	J62403	J4428	J61651	4"	J6096	4"	J6164
U4018	J6340	J6045	3"	J4428	J62383	3"	J62407	J62403	J4428	J61651	4"	J6096	4"	J6164
U4718	J6340	J6045	3"	J4428	J62383	3"	J62407	J62403	J4428	J61651	4"	J6096	4"	J6164
U5024	J6342	J6096	4"	J4428	Contact Sukup Mfg. Co.	4"	J62407	J62403	J4428	Contact Sukup Mfg. Co.	6"	J6096	4"	J6164
U6024	J6342	J6096	4"	J4428		4"	J62407	J62403	J4428		6"	J6096	4"	J6164
U7024	J6342	J6096	4"	J4428		4"	J62407	J62403	J4428		6"	J6096	4"	J6164
U10030	J6342	J6096	4"	J4428		4"	J62407	J62403	J4428		6"	J6096	4"	J6164

Table 7 – Siemens pipe train part numbers for natural gas-fueled dryers

LIQUID PROPANE

	ITEM #	1		2	3		4	5	6	7		8		9
DRYER MODEL	SIEMENS PIPE TRAIN	BALL VLV.	BALL SIZE	LOW PRESS. SWITCH	GAS VLV.	VLV. SIZE	ACTUATOR	ACT. & REG.	HIGH PRESS. SWITCH	BUTTERFLY VLV.	VLV. SIZE	BALL VLV.	BALL SIZE	1/2" PILOT REG.
U1512	J6362	J6087	1-1/2"	J4428	J62371	1-1/2"	J62407	J62403	J4428	J61265	2"	J6088	2"	J6164
U1812	J6363	J6087	1-1/2"	J4428	J6237	1-1/2"	J62407	J62403	J4428	J61311	2-1/2"	J6045	2-1/2"	J6164
U2012	J6363	J6087	1-1/2"	J4428	J6237	1-1/2"	J62407	J62403	J4428	J61311	2-1/2"	J6045	2-1/2"	J6164
U2412	J6363	J6087	1-1/2"	J4428	J6237	1-1/2"	J62407	J62403	J4428	J61311	2-1/2"	J6045	2-1/2"	J6164
U2712	J6363	J6087	1-1/2"	J4428	J6237	1-1/2"	J62407	J62403	J4428	J61311	2-1/2"	J6045	2-1/2"	J6164
U3018	J6365	J6088	2"	J4428	J6238	2"	J62407	J62403	J4428	J61321	3"	J6093	3"	J6164
U3518	J6365	J6088	2"	J4428	J6238	2"	J62407	J62403	J4428	J61321	3"	J6093	3"	J6164
U4018	J6366	J6045	2-1/2"	J4428	J62385	2-1/2"	J62407	J62403	J4428	J61651	4"	J6096	4"	J6164
U4718	J6366	J6045	2-1/2"	J4428	J62385	2-1/2"	J62407	J62403	J4428	J61651	4"	J6096	4"	J6164
U5024	J6366	J6045	2-1/2"	J4428	J62385	2-1/2"	J62407	J62403	J4428	J61651	4"	J6096	4"	J6164
U6024	J6367	J6045	3"	J4428	J62383	3"	J62407	J62403	J4428	J61651	4"	J6096	4"	J6164
U7024	J6367	J6045	3"	J4428	J62383	3"	J62407	J62403	J4428	J61651	4"	J6096	4"	J6164
U10030	J6367	J6045	3"	J4428	J62383	3"	J62407	J62403	J4428	J61651	4"	J6096	4"	J6164

Table 8 – Siemens pipe train part numbers for liquid propane -fueled dryers

See next page for identification of other pipe train part numbers.

Component Identification

LIQUID PROPANE

ITEM #	10	11	12	13	14	15	16	17
DRYER MODEL	PILOT SOLENOID VALVES	BUTTERFLY VALVE ACTUATOR	HIGH PRESSURE GAUGE	VAPOR GAS WYE STRAINER	LP SOLENOID VALVE	LP PRESSURE GAUGE	LP WYE STRAINER	VAPOR OT SWITCH
U1512	J6244	J62281	J5960	J6232	J6259	J5968	J6230	J5900
U1812	J6244	J62281	J5960	J6232	J6259	J5968	J6230	J5900
U2012	J6244	J62281	J5960	J6232	J6259	J5968	J6230	J5900
U2412	J6244	J62281	J5960	J6232	J6259	J5968	J6230	J5900
U2712	J6244	J62281	J5960	J6232	J6259	J5968	J6230	J5900
U3018	--	J62281	--	Contact Sukup Mfg. Co.	--	--	--	--
U3518	--	J62281	--		--	--	--	--
U4018	--	J62281	--		--	--	--	--
U4718	--	J62281	--		--	--	--	--
U5024	--	J62281	--		--	--	--	--
U6024	--	J62281	--		--	--	--	--
U7024	--	J62281	--		--	--	--	--
U10030	--	J62281	--		--	--	--	--

Table 9 – Pipe train part numbers for liquid-propane-fueled dryers
NOTE: Internal vaporizer used only on 12' dia. dryers

NATURAL GAS

ITEM #	10	11	12	13
DRYER MODEL	PILOT SOLENOID VALVES	BUTTERFLY VALVE ACTUATOR	HIGH PRESSURE GAUGE	VAPOR GAS WYE STRAINER
U1512	J6244	J62281	J5960	Contact Sukup Mfg. Co.
U1812	J6244	J62281	J5960	
U2012	J6244	J62281	J5960	
U2412	J6244	J62281	J5960	
U2712	J6244	J62281	J5960	
U3018	--	J62281	J5960	
U3518	--	J62281	J5960	
U4018	--	J62281	J5960	
U4718	--	J62281	J5960	
U5024	--	J62281	J5960	
U6024	--	J62281	J5960	
U7024	--	J62281	J5960	
U10030	--	J62281	J5960	

Table 10 – Pipe train part numbers for natural gas-fueled dryers

Switches



Images 7 and 8 – Rotary fill switch and fill sensor

Images 7 and 8 show rotary fill switch and sensor. Switch is located on roof of dryer and indicates when wet holding bin is full. **NOTE:** Appearance of switch may be different.



Image 9 – Single-point grain column temperature sensor

Image 9 shows single-point RTD (Resistance Temperature Detector). See Assembly Instructions L1987 shipped with RTDs.



Image 10 – Key switch



Image 11 – Key switch with key inserted

Image 10 shows key switch for access door. Image 11 shows switch with key inserted.

Grain Exchangers, Rotor Arm and Scrapers



Image 12 shows grain exchangers, viewed from top.

Image 12 – Grain exchangers



Image 13 shows rotor arm and scraper (curved) of unload.

Image 13 – Rotor arm and scrapers



Image 14 shows work light, alarm light and alarm buzzer.

Image 14 – Work light, alarm light, alarm buzzer

Blower Drive Shaft, Motor



Image 15 – Blower, drive shaft

Image 15 shows blower and drive shaft. **NOTICE:** Blowers for three- and four-fan dryers have backspin preventers that must be installed before operation and must remain on blowers. See Assembly Instruction L2491 and Maintenance section of this manual.



Image 16 – Blower motor

Image 16 shows blower motor and fan belts.

Louvers, Cleanouts, Roof Door



Image 17 – Louvers on door

Image 17 shows louvers on door. Louvered air vents help control amount of air pulled through grain for cooling.



Image 18 – Cleanout panel

Image 18 shows a cleanout panel at base of dryer. Cleanout panels are around base and near grain exchangers.



Image 19 – Roof door

Image 19 shows roof door.

Moisture, Temperature Sensors



Image 20 – Incoming moisture sensor

Image 20 shows incoming moisture sensor. Twist-clip latch allows for easy removal for cleaning sensor. (Cable color may be different.)

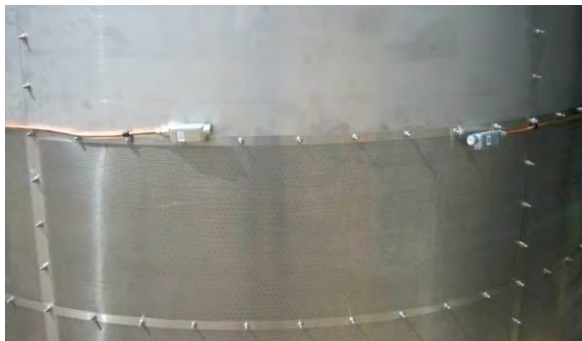

Image 21 – Outside over-temperature sensor

Image 21 shows outside over-temperature sensors.



Image 22 – Plenum RTD, capillary box

Image 22 shows plenum RTD and plenum over-temp capillary and junction box (lower). **NOTE:** There is usually a 40-60°F difference between temperatures at top and bottom of plenum. This should be considered when setting setpoint. If setpoint is 180°F, it will be 220-240°F at top of plenum.

Discharge Moisture Sensor, Grain Flow Tube

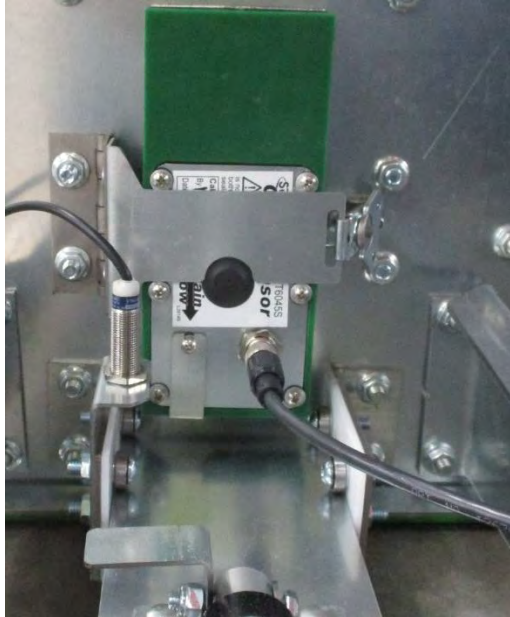

Image 23 – Discharge moisture sensor

Image 23 shows discharge moisture sensor in static sample box. Box is located underneath dryer.
(Cable color may be different.)

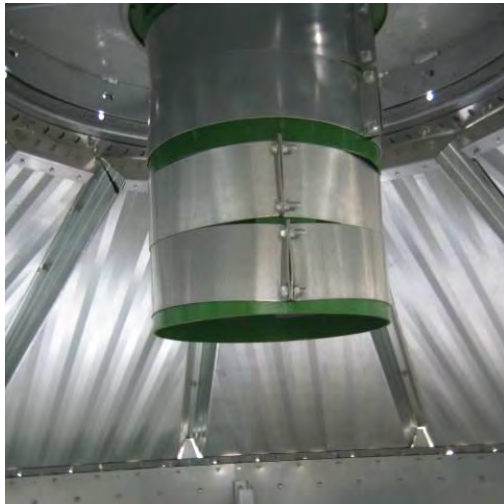

Image 24 – Grain flow tube

Image 24 shows grain flow tube. Sleeve clamps can be removed or added as needed to ensure grain does not press against roof of dryer. See installation instructions in appendices.

Touch Screen Controller

QuadraTouch Pro Controller



Image 25 – QuadraTouch Pro control screen

Control box (Image 25) should be mounted away from dryer and connected by shielded, direct-bury Ethernet cable. Cable is available in 50', 100', 150', and 200' lengths (J8720, J8721, J8722, J8723). Panel needs its own, independent 100VAC – 240VAC power supply.

Main power switch is on bottom, right-hand portion of box. See Image 25. When turned on, switch will illuminate to a green color. Panel will boot up shortly and connect with PLC inside power box.

To communicate with dryer, dryer must be powered up and System Control switch should be in QuadraTouch Pro position.

Back of QuadraTouch Pro panel is accessible by removing screws on bottom left and right corners of swing panel. See Image 25.

Although QuadraTouch Pro controller is contained in a sealed enclosure, it's a good idea to mount controller in a shed or other shelter.

QuadraTouch Pro controller has an operating temperature of 10°F to 135°F and a storage temperature of -4°F to 150°F. Outdoor placement is acceptable in most locations, but controller must not be left where temperature may be outside of storage range above. Cover of controller must be closed when unit is not in use.

QuadraTouch Pro controller comes with molded mounting brackets. These allow controller to be mounted directly onto wall or bench using four (4) screws.

NOTICE: If location where controller is mounted is not heated, unit must be taken into a temperature-controlled environment when not in use.

Operation

Table of Contents

Introduction	2-2
Setting Drying Temperature and Unload Speed	2-2
Calibrating Discharge Moisture Sensor	2-3
Calibrating Input Moisture Sensor	2-4
Dryer Start-up Preliminary Steps	2-5
General Operating Instructions	2-6
Dryer Shut-down	2-6

<u>DATE</u>	<u>REVISION</u>	<u>PAGE</u>
12/28/2022	– Updated note on grain drying speeds & holding capacities.....	3

Introduction

Sukup Tower Dryers use two variables to dry grain to desired moisture: plenum (drying) temperature and time of exposure to heat (unload speed). The higher the temperature, the faster the grain will dry. However, drying at too high a temperature can damage grain or, in worst case, burn it. Moving grain through dryer at a slower speed allows greater exposure to heat than running it through quickly. Speed of grain moving through columns of tower dryer is determined by speed of unload rotor, which is set by operator.

There are two modes of operation: Manual and Automatic. Manual operation should be used first in order to determine heat and speed levels that will dry grain to desired moisture level at discharge of dryer.

Before starting dryer, ensure that tarp has been removed from burner (Tarp is used to protect burner from moisture when not in use). As well, operator must close drain valve(s) on fuel line; remove and blow out copper tube for pilot light (if applicable) to ensure it is clear; and open valves to allow fuel into dryer's pipe train.

Sukup's QuadraTouch Pro control system provides for easy operation of dryer. Press Start button to begin, and then follow prompts that appear on screen. Software section elsewhere in this manual provides detailed instructions for QuadraTouch Pro system.

Before filling dryer with grain, turn blowers on to remove any dust and/or debris from burner and plenum areas.

NOTE: When initially starting dryer, it is best to fill it with dry grain before loading it with wet grain. This will help avoid/limit the need to transfer wet grain to a temporary holding bin. Since most drying occurs in upper half of dryer, grain at bottom during initial start-up will not heat up much (lose moisture) before discharge. So unless dryer is equipped with a way to recycle wet grain back through dryer, it is advisable to start with dry grain.

Setting Drying Temperature and Unload Speed

Optimum drying temperature and unload speed will depend on moisture of grain coming into dryer. Drying (plenum) temperature setpoints are typically between 140 and 180 degrees Fahrenheit.

Plenum temperature sensor is located in heat chamber near burner. Since heat rises, readings from sensor are typically 20 to 50 degrees lower than air temperature near top of heat chamber (plenum). For instance, a reading of 180 degrees could mean that air near top of dryer is 220 degrees and average temperature is 200 degrees. Keep this in mind when setting desired drying temperature. Also keep in mind that wetter grain at top of dryer needs more heat than dryer grain near bottom of dryer.

Use QuadraTouch Pro control screen and follow directions in QuadraTouch Pro software manual to set temperature and drying (unload) speed.

Use tables in Appendix C (and prior experience) for guidance in setting drying (unload) speed. Be sure to read introduction to tables.

Run dryer long enough to cycle one batch of grain completely through, then check moisture of grain discharged from dryer. If moisture is too high, reset drying (unloading) speed lower so grain stays in dryer longer. Changing speed in increments of 5 percent (unless moisture level is drastically higher than desired) will help in zeroing in on optimum drying speed.



Repeat process every 20 to 30 minutes until desired output moisture is achieved consistently and grain is not becoming overstressed (cracked kernels). If overheated (cracked or burnt) grain is coming out of dryer, reduce drying plenum temperature and unload speed accordingly until dryer is not damaging grain.

NOTE: It takes about 30 to 60 minutes for grain to move through a Sukup Tower Dryer running at maximum (100 percent) of drying (unload) speed, depending on dryer model. Holding capacities range from about 1,700 bushels in a Model U1512 dryer to about 10,500 bushels in a U10030 dryer.

After dryer is consistently producing grain at desired moisture level and quality, decide whether to run it in Automatic or Manual mode. Use QuadraTouch Pro control panel to choose which mode. In Automatic mode, user will have option of basing drying on grain temperature (at its hottest point) or moisture of grain exiting dryer.

Moisture is more difficult to measure consistently than temperature of grain in dryer. However, different varieties of grain may require different temperatures to dry to the same moisture level. Drying to a particular moisture content, such as 15 percent, generally produces more consistently dried grain.

Whether using plenum temperature or grain moisture as primary factor in drying grain, it is important to keep an eye on both factors, especially in commercial dryers where there is likely to be a variety of grain hybrids and moisture levels entering dryer.

In Automatic mode, to help dryer accommodate fluctuating levels of moisture of incoming grain, operator can set maximum and minimum drying (unload) speeds. Program both at 10 percentage points off of rate that would produce desired moisture level. For example, on a tower dryer that will be run at drying rate of 38 percent, set drying (unload) rate maximum at 48 percent and minimum at 28 percent. This lets dryer adjust unload rate some, but prevents it from getting too far off. Range can be set to be smaller if needed/desired.

Calibrating Discharge Moisture Sensor

IMPORTANT: Calibrating discharge moisture sensor to desired output moisture will help ensure proper drying of grain. It works best to calibrate sensor when actual grain moisture is as close to desired target moisture as possible. For instance, if 16% corn is desired, sensor should be calibrated when actual grain moisture is 16%.

It may be necessary to do an initial calibration when actual grain moisture is wetter or dryer than desired target, then another calibration when grain is at or near target moisture. Do this by running dryer in Continuous Flow for 30 minutes (or after Stabilization period) and then taking a sample from spout and checking it with an external moisture sensor known to be accurate. If readout is more than half a percentage point different than what dryer is showing (for instance, 17.5% moisture vs. 16.5%), dryer's sensor must be recalibrated. See recalibration steps under Tools Menu heading in Software Manual.

Take samples and check dryer's moisture sensor a few times a day. If it's off by .5% or more, put unload on pause, remove sensor from dryer and check for any dust or debris buildup on sensor or metal tube around sensor. Replace sensor and resume unloading. Check moisture again. If it's still off by .5% or more, calibrate sensor again.



Calibrating Input Moisture Sensor

Enter temperature of incoming grain on QuadraTouch Pro touch screen. Follow directions on touch screen to calibrate.

NOTE: Grain variety, maturity level, cleanliness, weather conditions and operation can all affect performance of dryer. To the extent possible, be aware of different varieties of grain being fed into dryer, as no two varieties dry identically.

IMPORTANT: Unload rotor, fan(s), and heater(s), along with auxiliary fill and take-away equipment, will start without warning during dryer operation. Use extreme caution around grain handling system.

NOTE: Please refer to Software Manual for a detailed description of each operation mode. Software is frequently updated, so content may differ slightly from descriptions in this manual.

Make sure to go through steps in Maintenance section before initial, daily or seasonal operation of dryer.

Before Loading or Starting Dryer

Dryer Start-up Preliminary Steps



Image 2-1 – System Control switch, Emergency Stop button

Prior to starting dryer, pull out red Emergency Stop button. See Image 2-1. It will illuminate when pulled out. Turn System Control switch to “QuadraTouch Pro,” then turn Main Disconnect switch (shown in Image 2-2) to “On” position.



Image 2-2 – Main Disconnect switch

IMPORTANT: Turn switch off when dryer is not in use. This will cut power to programmable logic controller (PLC) and other components, protecting them from potential damage in case of a power surge.

NOTE: If outside air is below 32°F, turn switch on 15-20 minutes before use to warm up burner valves.

Operation

Before starting dryer, ensure that the latest operating software has been downloaded. Go to <http://www.sukup.com/Products/QuadraTouch> to download the latest version.

Sukup's QuadraTouch Pro control system provides for easy operation of dryer. Press Start button to begin, and then follow prompts that appear on screen.

1. Run dryer in Manual mode at unload speed from applicable drying table in Appendix C, or based on past experience.
2. When four-point average temperature of columns is within about 3°F to 5°F of target temp (likely 110°F to 130°F), switch to Automatic, Temp-Based mode and run for about an hour.
3. Enter target temp based on past experience or an educated estimate (120°F is a good place to start).
4. Change unload Multiplier or Gain setting to 100 F. Change Deadband settings to 0 and 0.
5. As dryer settles in on target temp, take moisture samples and increase or decrease target temp as needed in 30- to 60-minute increments (2°F temp changes recommended). If grain is too dry, decrease temperature setpoint. If grain is too wet, increase column setpoint.

For further information, refer to Software Manual.

IMPORTANT: Temperatures inside of plenum will vary widely from bottom to top. For example, a plenum temp setting of 180°F may produce a temperature of 220°F at top of plenum. Wetter grain at top of dryer can withstand higher temperatures than drier grain at bottom. For this reason, temperature sensor is located at bottom of plenum. If there are signs of burned kernels or other heat damage to grain, reduce plenum temperature.

Dryer Shut-down

Pressing "Reset" button on QuadraTouch Pro controller will shut down dryer in proper sequence. To allow fan to continue running, use Fan Start Delay option from Settings Menu. **NOTE:** Never leave grain in dryer for extended periods of time.

Maintenance

Table of Contents

Periodic Maintenance	3-2
Prior to Operation.....	3-2
Cleaning During Drying Season.....	3-3
Pre-Winter/End-of-Season Maintenance.....	3-3
Component Maintenance.....	3-5
Blower, Unload Motors	3-5
Greasing Blower Bearings.....	3-6
Checking Backspin Preventer	3-8
Tensioning Belts	3-9
Gearbox Lubrication	3-10
Unload Rotor Bearing Lubrication	3-11
Burner Maintenance	3-12
Cleaning Divider Panels	3-13

<u>DATE</u>	<u>REVISION</u>	<u>PAGE</u>
12/28/2022	– Updated blower motor part numbers	5
	Added specifications for Models U1512 & U10030	5, 6, 9 & 10

Periodic Maintenance

Good maintenance practices can make start-up easier and will help to ensure good performance each drying season. The following guidelines are **minimum** recommended procedures to be carried out.

NOTICE: Do not leave grain in dryer without dryer running for longer than 24 hrs. Grain can absorb moisture and expand, putting unnecessary stress on screens and on dryer itself.



WARNING: When using ladder attached to dryer, make sure ladder is dry before climbing. Ladder may be slippery when wet. Falling from ladder could cause death or serious injury.

IMPORTANT: All bolts used to enclose access points after maintenance **MUST** be securely retightened to prevent undesired access.

PRIOR TO OPERATION

Burner	<ul style="list-style-type: none">• Inspect closely to make sure no gas ports or holes are blocked.
Fan(s)/Heater	<ul style="list-style-type: none">• Check wiring for loose connections, bare wires, or rodent damage.• Check heater ignition wires for damage or shorting.
Motor(s)	<ul style="list-style-type: none">• Check openings for blockage.• Inspect belts for tension, cracks or excessive wear.
Moisture Sensor	<ul style="list-style-type: none">• Make sure moisture sensors are clean.• Check condition of cable.
Pipe Train	<ul style="list-style-type: none">• Inspect pipe train components for physical integrity and tightness.• Open drain valve on pipe train. Make sure no water is in it or in pilot gas line. (Close drain valve before turning on gas supply.)
Unload	<ul style="list-style-type: none">• Inspect rotor for obstructions.• Make certain rotor turns freely.

Whenever maintenance is performed, check all fasteners and retighten as needed.

The most important maintenance on any grain dryer is keeping it clean. Clean dryers run more efficiently, have higher capacity, are safer and have a significantly lower risk of fire.

Items listed below should be checked daily and cleaning operations performed as needed. **Differences in each season's grain will affect amount of cleaning needed.** For example, in a season when grain is unusually dirty, some parts of dryer may require attention daily or every few days, while in another season they will need weekly care.

CLEANING DURING DRYING SEASON

Burner	<ul style="list-style-type: none"> • Clean off all fines and debris, especially after cleaning interior screens. If not removed, debris could ignite.
Catwalk	<ul style="list-style-type: none"> • Clean catwalk walking surface; it can become slippery with buildup of fines.
Cooling Chamber	<ul style="list-style-type: none"> • Remove fines and debris on floor (where unload rotor gearbox and motor are located). • <u>Keep divider between cooling chamber and heating section clean.</u> Build-up could damage dryer.
Grain Discharge	<ul style="list-style-type: none"> • Clean out to ensure uniform flow of grain and prevent clogs.
Screens (Exterior)	<ul style="list-style-type: none"> • Inspect and clean with broom, pressure washer or shop vacuum to remove dust, fines and bees wings. (Can be reached from service catwalks.)
Screens (Interior)	<ul style="list-style-type: none"> • Inspect and clean with broom.

PRE-WINTER/END-OF-SEASON MAINTENANCE

Burner	<ul style="list-style-type: none"> • Clean with shop vacuum. • <u>Install tarp or cover over burner or entire burner can.</u> (Prevents debris from collecting; prevents water from entering pipe train.)
Dryer	<ul style="list-style-type: none"> • Empty dryer. Do not use it to store grain.
Grain Table	<ul style="list-style-type: none"> • Clean, especially around columns on outside. (Floor and sweep are stainless steel, but columns are galvanized, thus susceptible to deterioration and corrosion.)
Oil Drain Cap*	<ul style="list-style-type: none"> • Remove cap on bottom of oil drain. Remove any buildup. Drain any waste oil into container for responsible disposal.
Pilot Gas Line*	<ul style="list-style-type: none"> • Disconnect and plug to prevent water/moisture freeze during cold weather
Pipe Train Drain Valve*	<ul style="list-style-type: none"> • Shut off gas. • <u>Open drain valve on bottom of vertical gas line (it is a quarter-turn ball valve) to allow drainage of moisture.</u> Water allowed into pipe train could freeze and break expensive components.
Y-Strainer*	<ul style="list-style-type: none"> • Remove screen, clean it and reinstall it.

* See photos and identifiers on next page.

NOTICE: When tower dryer is not in regular use, burner should be tarped. Also, gas supply to dryer should be shut off and pipe train drain valve should be opened to prevent water from getting into pipe train valves.

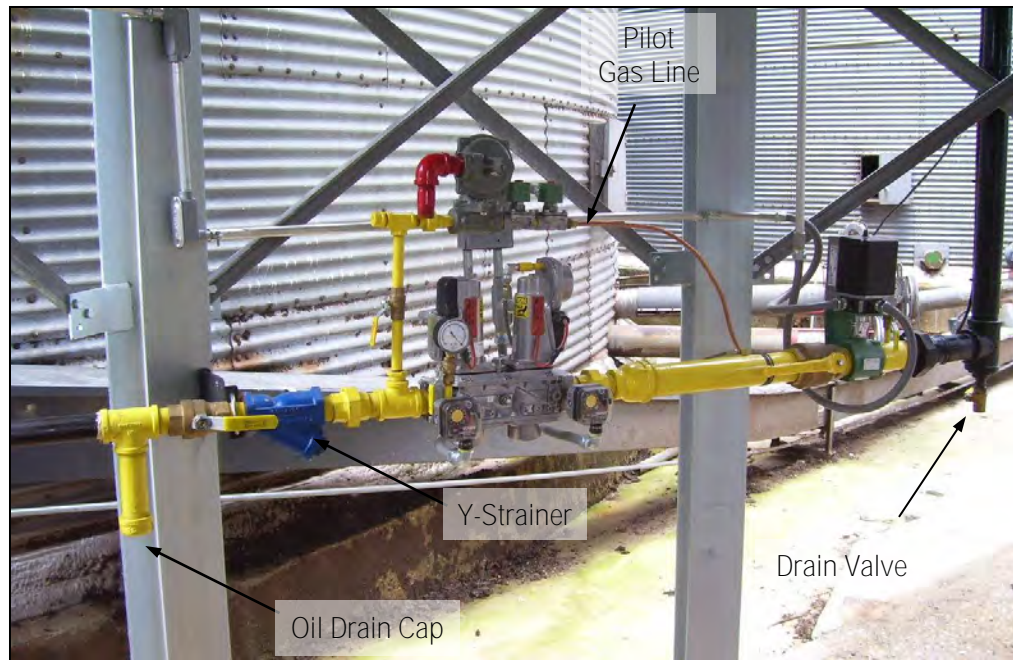

Image 3-1 – Pipe train components

Component Maintenance

Blower, Unload Motors

See Table 3-1 to identify blower motor and Table 3-2 to identify unload motor used on each model of tower dryer, as well as electrical loads.

Model #	Blower Motor HP	Motor Pt. #	Service Factor	FLA 460V (w/SF)	FLA 230V (w/SF)	FLA 208V (w/SF)
U1512	75	H7505W	1.25	108	215	225
U1812	75	H7505W	1.15	98	197	217
U2012	100	H7510W	1.15	129	259	286
U2412	100	H7510W	1.15	129	259	286
U2712	125	H7511W	1.25	172	N/A	N/A
U3018	50 (3)	H7210B	1.15	67	135	144
U3518	60 (3)	H7260B	1.15	80	160	170
U4018	75 (3)	H7505W	1.15	98	197	217
U4718	75 (3)	H7505W	1.15	98	197	217
U5024	100 (3)	H7510W	1.15	129	259	286
U6024	100 (3)	H7510W	1.15	129	259	286
U7024	125 (3)	H7511W	1.25	160	N/A	N/A
U10030	125 (4)	H7511W	1.15	160	N/A	N/A

Table 3-1 – Blower motor specifications

Model #	Unload Motor HP	Motor Pt. #	Service Factor	FLA 460V (w/SF)	FLA 230V (w/SF)	FLA 208V (w/SF)
U1512	1.5	H1445	1	2.3	4.6	5.1
U1812	1.5	H1445	1	2.3	4.6	5.1
U2012	1.5	H1445	1	2.3	4.6	5.1
U2412	1.5	H1445	1	2.3	4.6	5.1
U2712	1.5	H1445	1	2.3	4.6	5.1
U3018	2	H2040	1	3	6	6.6
U3518	2	H2040	1	3	6	6.6
U4018	2	H2040	1	3	6	6.6
U4718	2	H2040	1	3	6	6.6
U5024	3	H2980	1	4	8	8.8
U6024	3	H2980	1	4	8	8.8
U7024	3	H2980	1	4	8	8.8
U10030	7.5	H4760	1	10	NA	NA

Table 3-2 – Unload motor specifications

Greasing Blower, Unload Motors

Motor bearings are greased at factory. Lubricate at start of each season. Use Shell Dolium R or Chevron SR1 No. 2 grease – 1 to 2 strokes for 1.5 HP to 3 HP motors; 2 to 3 strokes for 50 HP to 70 HP motors; 3 to 4 strokes for 100 HP and 125 HP.

Greasing Blower Bearings

See Table 3-3 for blower bearing greasing frequency and type of grease to use.

NOTICE: Bearings are not sealed. Pump grease until it begins coming out of bearings.

NOTICE: Shaft should be turned at least monthly. See lubrication sticker on blower for additional information. See Images 3-2 and 3-3.

Model #	Blower Model	Part #	Shaft Dia.	RPM	Bearing Greasing Interval	Type of Grease
U1512	ESI490	J7717	3-7/16"	1000	45 days	*
U1812	QSL542	J7716T	2-5/16"	900	45 days	**
U2012	QSL542	J7716T	2-5/16"	964	45 days	**
U2412	QSL600	J7709T	3-7/16"	800	45 days	**
U2712	QSL600	J7709T	3-7/16"	890	45 days	**
U3018	QSL402 (3)	J7702T	2-3/16"	1270	45 days	**
U3518	QSL445 (3)	J7704T	2-7/16"	1110	45 days	**
U4018	QSL490 (3)	J7701T	2-11/16"	990	45 days	**
U4718	QSL490 (3)	J7701T	2-11/16"	1040	45 days	**
U5024	QSL542 (3)	J7703T	2-15/16"	940	45 days	**
U6024	QSL600 (3)	J7705T	3-7/16"	815	45 days	**
U7024	QSL600 (3)	J7705T	3-7/16"	890	45 days	**
U10030	QSL600 (4)	J7720	3-15/16"	730	45 days	**

Table 3-3 – Blower models, greasing specifications

* Lubricate with following grease or equivalent: Shell Alvania EP No. 2, Texaco Molytex No. 2, Mobile Mobilux EP2, Gulf Golfcrown No. 2.

** Lubricate with high-quality NLGI No. 2 lithium-based R&O grease w/ minimum oil viscosity of 500 SUS at 100 ° F. Examples: Shell Alvania RL, Mobil Mobilith SHC100 or SHC220, Exxon Ronex MP.



Image 3-2 – Twin City Fan & Blower lubrication sticker

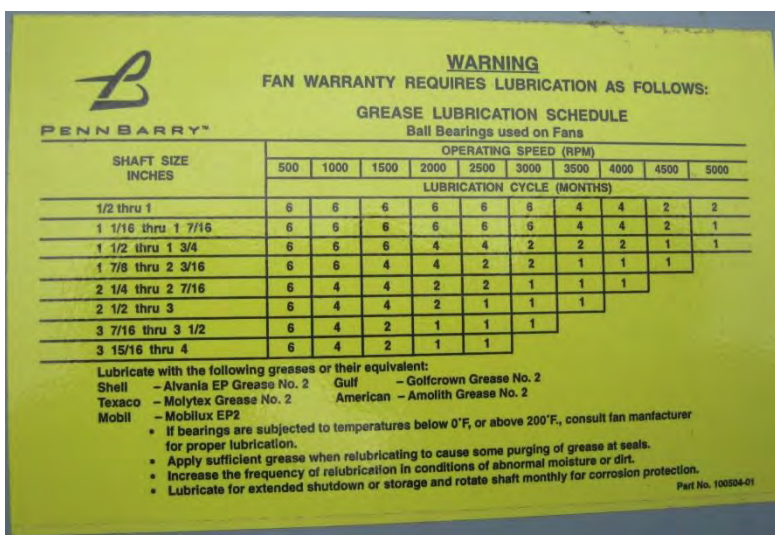

Image 3-3 – Penn Barry blower lubrication sticker



Image 3- 4 – Grease zerks for blower shaft bearings

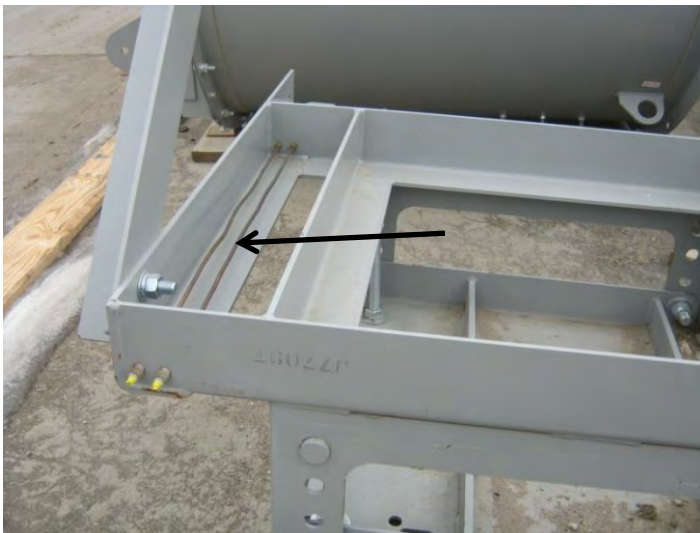

Image 3-5 – Base for blower

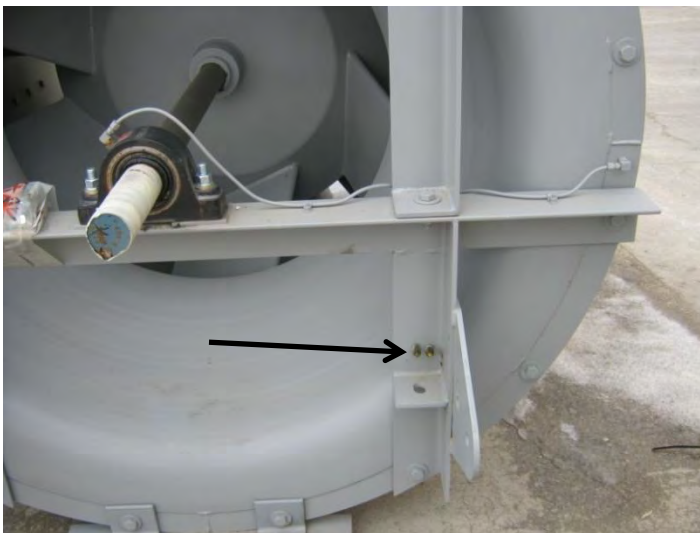

Image 3-6 – Grease zerks for blower shaft bearings

Images 3-4 and 3-6 show grease zerks for shaft bearings. Blowers are shown prior to installation. When placed upright on base, zerks will be connected to grease feeding tubes shown in Image 3-4. Bearings are packed with grease at factory, but must be re-lubricated periodically. See table on previous page for frequency. Make sure tubes are full of grease if not filled at factory. Use zerks at front of blower base to apply grease.

Image 3-7 shows blower installed in tower dryer.



Image 3-7 – Blower installed

Checking Backspin Preventer

A backspin preventer is used on each blower of a multi-fan tower dryer to prevent improper fan rotation. Image 3-8 shows proper installation. Each device should be checked annually and is accessible by removing lid from top of blower. See Image 3-9. Ensure clutch housing is firmly in place on drive shaft. If loose, tighten using socket-head screw (see Image 3-10) to a maximum of 38 to 40 ft. lbs. Ensure arms are securely bolted to unit as shown in Image 3-10. Check and retighten cable hardware as needed. **NOTICE:** Cable deflection should be between 3/4" and 1-1/2" per side, with maximum total deflection of 3". Failure to properly adjust could result in product damage.

If clutch housing needs to be removed, loosen socket-head screw. When reinstalling backspin preventer, ensure shaft goes completely into clutch housing. Tighten socket-head screw to a maximum of 38 to 40 ft. lbs.

NOTICE: Verify that each blower's drive shaft rotates clockwise as seen from above before bolting arms to clutch housing shaft. Failure to do so could result in damage to motor, belts and/or blower when started.



Image 3-8 – Backspin preventer installed



Image 3-9 – Shaft cover plate on top of blower

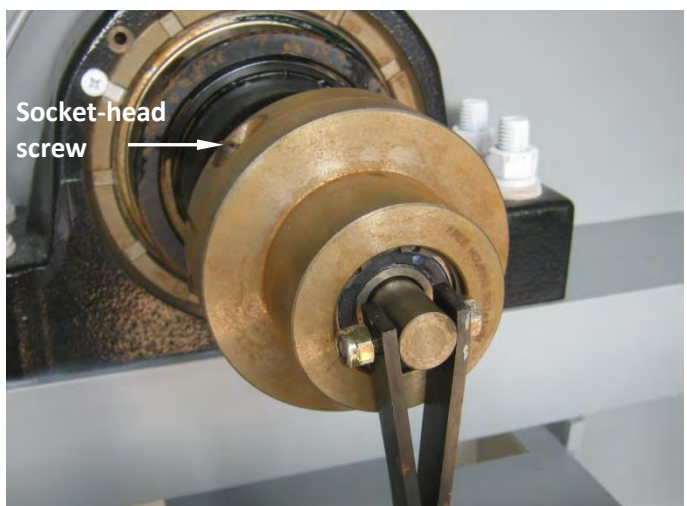

Image 3-10 – Socket-head screw on clutch housing

Tensioning Belts

See Table 3-4 and Fig. 3-1 to properly tension belts.

Model #	Belt Part #	# of Belts	Belt Profile / Length	Small (motor) pulley dia. (inches)	Large (driven) pulley dia. (inches)	Deflection (inches)	Pounds of force for new belt	Pounds of force for used belt
U1512	J0283	4	5VX / 1060	7.4	13.1	0.56	22.1	14.8
U1812	J02751	3	CX / 124	9	18	0.64	21.8	14.7
U2012	J0276	4	CX / 144	13	24	0.67	23.5	15.9
U2412	J02761	4	CX / 136	11	24	0.63	23.5	15.9
U2712	J02763	4	CX / 140	12	24	0.65	23.5	15.8
U3018	J0263	6	CX / 96	10	14	0.46	23.5	15.9
U3518	J02803	6	CX / 109	10	16	0.5	23.5	15.9
U4018	J0277	9	CX / 112	10	18	0.51	23.5	15.9
U4718	J0277	9	CX / 112	10-1/2	18	0.53	23.5	15.9
U5024	J0275	12	CX / 128	9-1/2	18	0.67	21.8	14.7
U6024	J02761	12	CX / 136	11	24	0.7	23.5	15.9
U7024	J02763	12	CX / 140	12	24	0.65	23.5	15.8
U10030	J02838	20	5VX / 1360	9.65	23.5	0.64	22.1	14.8

Table 3-4 – Blower belt specifications

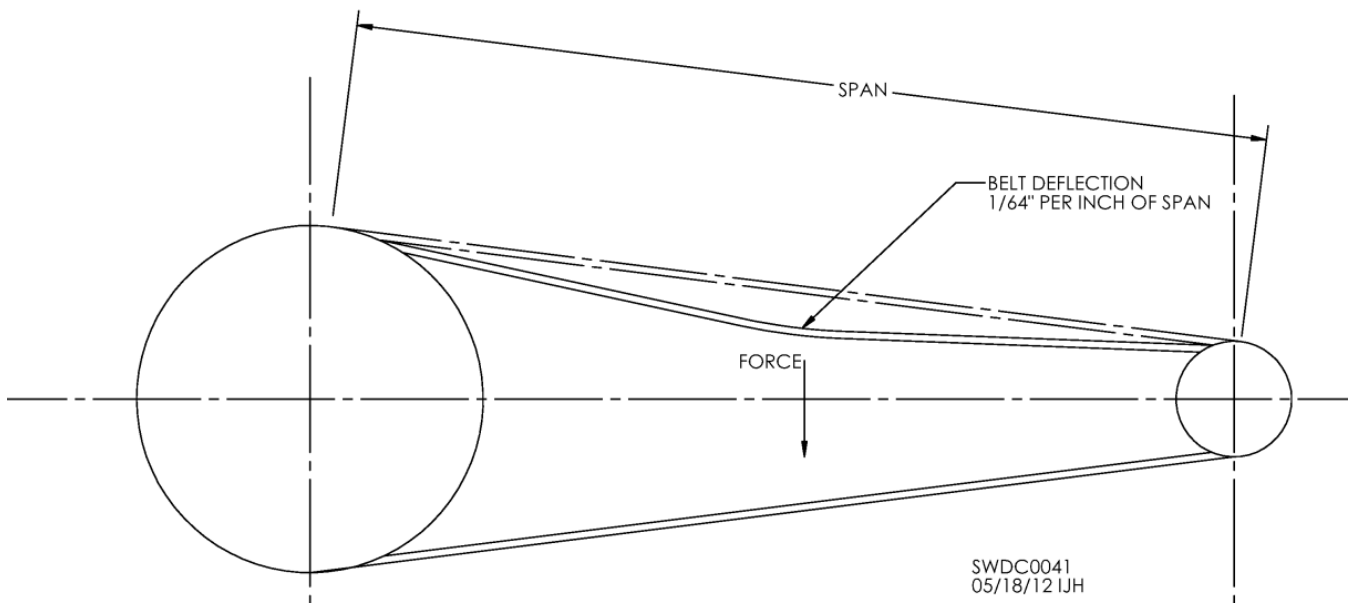

Fig. 3-1 – Adjusting belt tension

Follow these steps to tension belt.

1. Measure span length. See Fig. 3-1.
2. At center of span, apply enough force to deflect belt 1/64" for every 1" of belt span. If span is 32", deflection amount should be 32/64", or 1/2".
3. Use Table 3-4 to determine pounds of force to apply to gauge proper deflection per belt.

Gearbox Lubrication

See Table 3-5 and Images 3-11 through 3-13 for gearbox lubrication specifications and locations.

Model #	Gearbox	Part #	Oil Change Interval	Amount of Oil	Type/Weight of Oil
U1512	Rossi	J36873	2 to 4 yrs.	3.38 qts.	ISO VG 320
U1812					
U2012					
U2412					
U2712					
U3018	Shimpo	J3685	Gearbox is packed with grease at factory. No re-lubrication is required.		
U3518					
U4018					
U4718					
U5024	Sumitomo	J3686	Gearbox is packed with grease at factory. Add 8 oz. Shell Alvania No. 2 grease each year.		
U6024		J36865			
U7024					
U10030					

Table 3-5 – Gearbox lubrication specifications



Image 3-11 – Rossi gear reducer



Image 3-12 – Shimpo gear reducer



Image 3-13 – Sumitomo gear reducer

Image 3-11 shows Rossi gear reducer used on models U1512 through U2712, including oil fill (F), level (L) and drain (D) plugs. See Table 3-5 for oil change frequency, amount and type.

Image 3-12 shows Shimpo gear reducer used on models U3018 through U4718. Reducer is grease-packed at factory and does not require periodic re-greasing.

Image 3-13 shows Sumitomo gear reducer used on models U5024 through U10030, including location of grease zerk (G). Reducer is grease-packed at factory. See Table 3-5 for information on maintaining grease level.

NOTE: All reducers are shown in factory packaging.

Unload Rotor Bearing Lubrication

Image 3-14 shows typical unload rotor bearing used in Sukup tower dryers. All models use bearing J0064 (for 3-1/2" dia. shaft). Bearings are grease-packed at factory with lithium-based grease. On dryers running 8 to 16 hours a day, bearings should be re-greased every 12 weeks. On dryers running 24 hours a day, bearings should be re-greased every 10 weeks. Use lithium-based grease. **NOTICE:** Do not over-grease bearing. It can break bearing seal. Image 3-14 shows location of grease zerk.



Image 3-14 – Bearing used on unload rotor

Burner Maintenance

Maxon Corporation provides the following information

Periodic maintenance will ensure continued trouble-free operation of Series NP-LE AIRFLO® Burner system.

Inspect burner at least once a year. Previous experience is the best guide in determining frequency of inspection. As a minimum, the following procedure should be followed:

1. Shut system down totally. Disconnect or lock out power supply so there can be no accidental start-up during inspection.
2. Inspect burners carefully, including upstream and downstream sides of mixing plates as well as burner body face. Any accumulation of scale or foreign material of either side of mixing plates should be removed with a wire brush. Check visually that no holes in mixing plates are blocked.

NOTICE: Do not enlarge burner ports or performance may be drastically affected!

3. If any mixing plates are loose or are missing fasteners, tighten/replace as necessary. Always use zinc plated or stainless metric fasteners.

Inspection and Maintenance of Gas Ports

- Conduct initial inspection within first month after commissioning. Visually check gas ports of new burner assemblies for any piping scale or debris. Use pin vise with drill bit to remove.
- Annual inspections are normally adequate once initial piping debris is removed. Operating conditions of burner will determine how frequently maintenance is required.
- Use of an electric drill is not suggested unless both pin vise and drill can be chucked up in a variable-speed drill unit. **CAUTION:** It is easy to snap bits off in a port when using a drill motor, and removal of broken bits from gas ports is difficult.

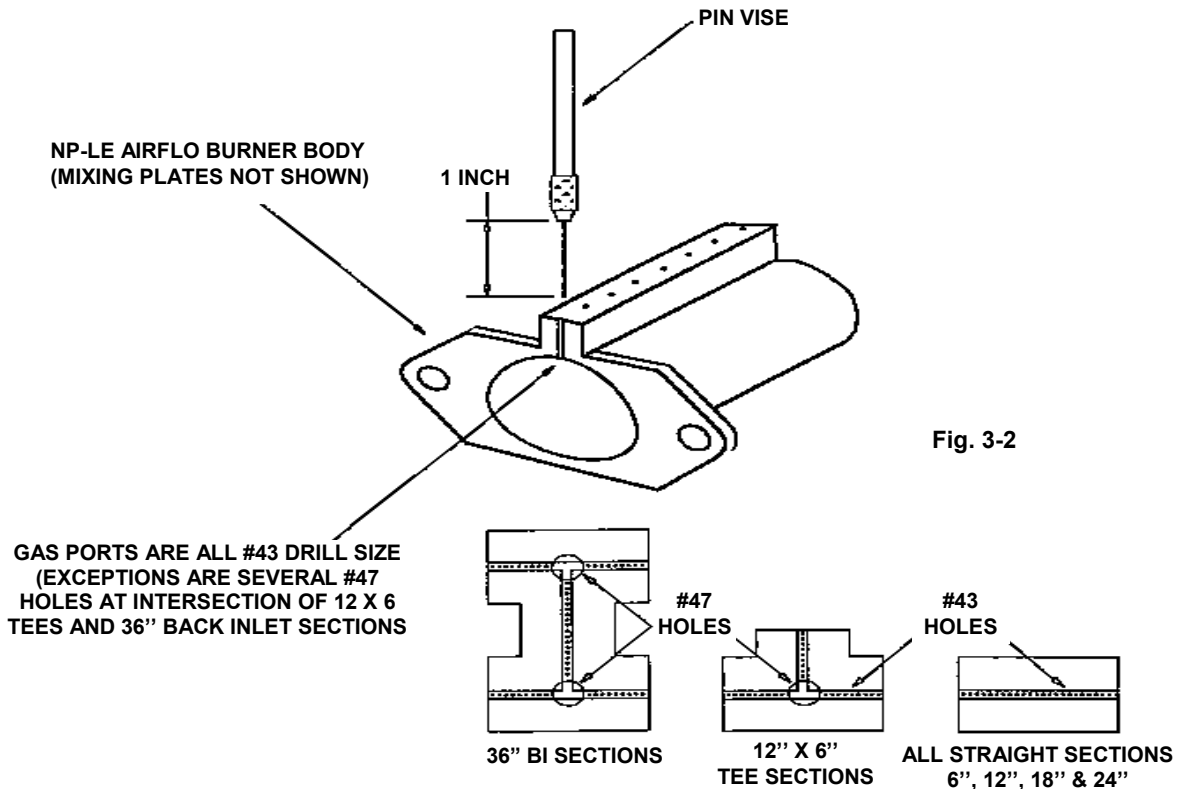

Cleaning Divider Panels

It is critical that cone panels (divider) between cooling chamber and heating section be kept clean. Gap between inner and outer cone panels must be unobstructed. See Image 3-15. Use an air blower, poking stick or broom to clean daily to prevent buildup of debris. Panels can be accessed via outside door and inside platform. See Fig. 3-4 and Fig. 3-5. Depending on dryer model, sections of inner platform can be removed to clean cone panels.

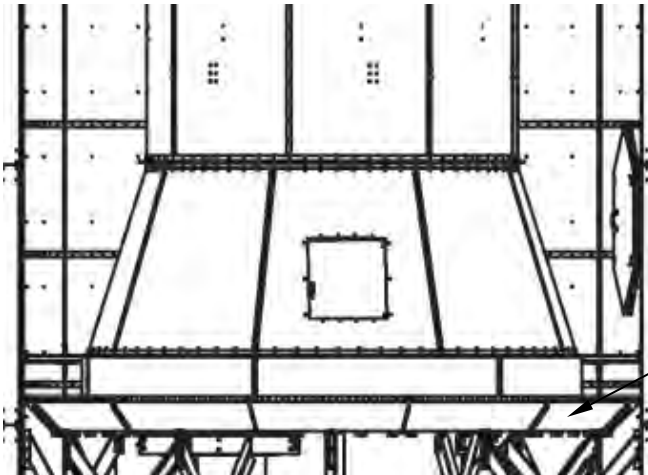

Fig. 3-3 – Divider panels

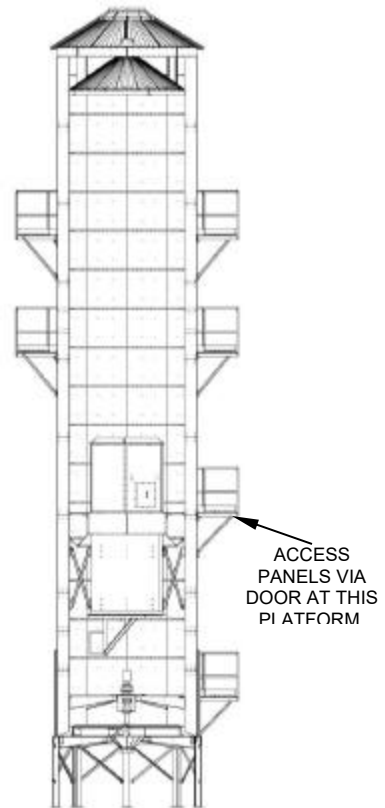

Fig. 3-4 – Accessing divider panels

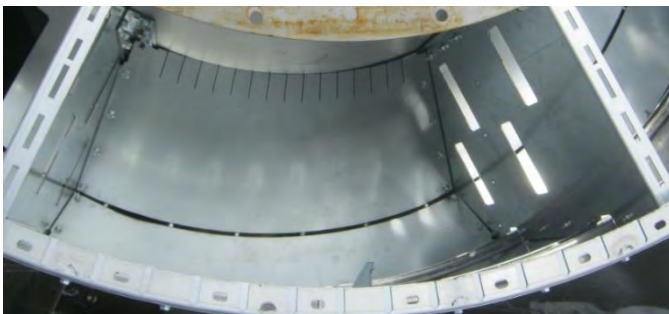

Image 3-15 – Gap between inner & outer cone panels

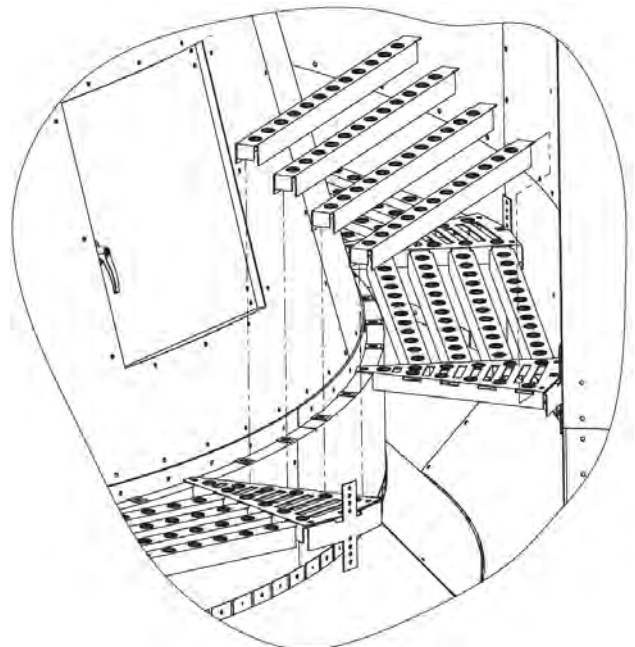

Fig. 3-5 – Inner platform w/ removable planks

Troubleshooting Guide

Table of Contents

Quick-reference Troubleshooting	4-2
Component Troubleshooting	4-3
Rotary Fill Switch	4-3
Vapor Over-Temperature Switch	4-4
Access Door Switches	4-5
Grain Column Over-Temperature Switch	4-6
Blower Air Switch	4-7
Plenum Over-Temperature Switch	4-8
Incoming/Discharge Moisture Sensors	4-9
QuadraTouch Pro Controller	4-10
Plenum/Grain Column Temperature Sensor RTD & Transmitter	4-11
Single-point RTD Sensor & Transmitter Wiring Diagram	4-13

<u>DATE</u>	<u>REVISION</u>	<u>PAGE</u>
12/28/2022	– Updated vapor over-temp switch troubleshooting instructions	4
	Added reference to wire used for Blower 4 air switch	7
	Updated instructions for fixing a communication error	10

Troubleshooting

See table below for quick-reference guide to troubleshooting.

See following pages for help in troubleshooting problems with specific components of dryer.

See Sensor/Switch Locations pages in Component Identification section of this manual.

Problem/Fault	Possible Cause or Solution
Pilot flame does not light	<ul style="list-style-type: none"> • Make sure low-fire position switch by valve is closed. • Make sure both pilot solenoid valves are opening. • Make sure spark transformer is receiving power. • Make sure spark plug is clean. • Check for blockages in pilot gas line.
Pilot flame of flame is not sensed	<ul style="list-style-type: none"> • Visually inspect to make sure pilot flame is lighting. If not, see above problem. • At burner, check that flame rod is clean and not touching something. • Check connection of flame rod at burner and back to control box terminal. • Make sure ground wire is attached to burner and to ground terminal in control box. Also make sure there is a ground wire between power box and control box.
Burner is not reaching setpoint	<ul style="list-style-type: none"> • Ensure there is no obstruction of fuel to burner. • Gas pressure may need to be increased to reach high temperatures. • If not reaching low setpoint, low-fire position of valve may need to be decreased.
No grain unloading out of dryer	<ul style="list-style-type: none"> • Check unload motor wires in power box and at motor on dryer. • Ensure 28VDC run signal is going to frequency drive. • Ensure that reference voltage is going to drive unit. • If drive is receiving run signal and reference voltage, display on unit should be showing a number. This is the frequency sent to unload motor. Ensure unload rotor is turning and rotor arms are not hitting on floor or on side of dryer. Drive unit will cut voltage to motor if it starts drawing higher amps than motor will allow (current limiting).
Upper column high limit fault	<ul style="list-style-type: none"> • The 240-degree switch is located in a copper tube on top of first perforated sheet on outside of dryer. • Dryer plenum temperature may be set too high. • If grain level dropped below sensor, hot air will start blowing on sensor, causing it to trip. • Wet grain level in storage bin may be getting too low. • Dryer is unloading faster than fill system can fill dryer, causing grain to drop below sensor.
No grain column temperature	<ul style="list-style-type: none"> • Take a voltage reading between DC COM (95) and signal wire (70). This should be between 1 – 5 VDC. Take reading to control box. • If voltage is not present between 95 and 70, voltages and resistance need to be checked on sensor. • At transmitter, disconnect wires coming from sensors and take a resistance reading from purple to blue on the two-pin plug. Resistance should be between 900 and 1,500 Ohms. If reading is within range, sensors are OK. • If resistance is out of range, disconnect RTD cables from column RTD terminals (See drawing on Page 4-13) and check resistance of each. Readings should be between 900 and 1,500 Ohms. Sensors not in this range must be replaced. • At transmitter, check voltage between +28VDC terminal and COM (orange wire to black). This should read 28VDC. If 28VDC is present, reconnect sensor wires and check output signal at transmitter (pink wire to black). This should be the same as before (1-5VDC). • If still no voltage on output, transmitter needs to be replaced.
Moisture sensor not working	<ul style="list-style-type: none"> • Remove sensor and inspect it for damage to temperature sensor tube or flag. Also make sure that it is clean and free of debris. Any kind of buildup on sensor will cause inaccurate moisture readings. • Take a voltage reading on moisture sensor wire and terminals in power box and control box: White = ground, Brown = 28VDC supply to sensor, Blue = 0-3V (return voltage for temperature), Black = 0-10VDC (return voltage for moisture).

Rotary Fill Switch



Image 4-1 – Rotary fill switch

Rotary fill switch is located on roof of dryer. It is used to indicate when wet bin of dryer is out of grain. A fault will be displayed when this occurs.



Fault Condition Message Depends on Fail Type

All dryer models use wire 53

1. Is wet bin out of grain?
If this is last load of season, press Reset and Start.
2. Has an auxiliary load malfunctioned?
Repair cause of load failure and press Reset.
3. If wet grain is available and load auxiliaries are functioning, is fill switch bound up?
If so, free the fill switch and repair cause.
4. Are both PLC input lights off? (Both lights should be off when dryer is calling for grain.)
Are both PLC input lights on? (Both lights should be on when dryer is full.)
If not, remove cover from fill switch and visually check sensors for proper placement in their respective holders. See Image 4-1.
5. Check PLC input lights (44-Lower; 53-Upper) while someone stops fill switch. If either PLC input light does not turn on, check for 28VDC on wire 18 to ground. (Touch black probe from meter to dryer frame.)
6. If 28VDC is detected on wire 18, check for 28VDC on other wire going to sensor.
 - a. With fill switch not spinning, 28VDC should be detected on wire 44 or 53.
 - b. If not, replace respective sensor and recheck for voltage.
7. If 28VDC is detected at power box terminal strip and PLC input lights are not on, PLC may be malfunctioning.



Images 4-2 & 4-3 – Rotary fill switch, fill sensor

NOTE: Appearance of switch may be different.

Vapor Over-Temperature Switch



Image 4-4 – Vapor over-temp switch

On an LP dryer, vapor over-temp switch is located on pipe train. Its purpose is to detect gas that is overheating and prevent damage to heater components. See Image 4-4.

Fault message will appear and dryer will shut down if vapor temp gets above 140°F. Vapor pipe should be warm, but not too hot to touch.



Fault Condition Vapor Over-Temp

All dryer models use wire 37

1. Check fuel supply. Is tank low on fuel? If so, fill tank.
2. Check for air inlet obstruction. Remove any debris.
3. Has vaporizer coil had sufficient time to cool down? Switch will automatically reset when it has cooled down.

4. Is PLC input light on? After switch has cooled down and reset, PLC input light should be on. If not, follow wires to heater box and check for 28VDC on terminal 18.
5. If 28VDC is not found on terminal 18, go to main power box and check for 28VDC on terminal 18. If 28VDC is found on terminal 18 in main power box, check wiring connections from heater box to main power box.
6. With 28VDC being found on wire 18 on one wire of vaporizer O/T switch, and after switch has cooled down to ambient temperature, check for 28VDC on other wire coming from over-temperature switch.
 - a. If 28VDC is NOT found on other wire, O/T switch must be replaced.
 - b. If 28VDC is found on other wire coming from O/T switch, take note of wire number and go to power box and check for 28VDC on terminal 18.
 - c. If 28VDC is NOT found on power box terminal 18, check wiring connections between power box and heater box.
 - d. If 28VDC is found on input terminal, and input light is NOT on and fault message is still displayed (after switch has reset), then PLC is malfunctioning.

Access Door Switches



Image 4-5 – Access door switch

Access door switches, also called key switches, are located on each door on dryer. The switches are used to keep dryer from running when a door is open and a person may be inside of tower dryer.



Fault Condition
Door is Open

All dryer models use wire 6.

1. Check doors to be sure no one is inside and doors are closed.
2. If doors are closed, check that PLC input light is ON. If light is **not** ON, go to junction box that contains wire from switches. Remove cover and check for 28VDC on input wire.

NOTE: On ALL dryers, wire 18 feeds into door switches. Switches are connected in series and route back to PLC input.

3. If 28VDC is not present on input wire, check that 28VDC is present on wire 18.
 - a. If 28VDC is present on input wire, but PLC input light is not ON, check for 28VDC returning from both switches. Generally, each additional door switch adds a letter to wire number after coming out each successive key switch: 36, 36A.
 - b. If 28VDC is not returned from door switches, a voltage check on wire coming from each switch may be required.
4. If 28VDC is being returned from last switch, check for 28VDC on appropriate wire on power box terminal strip.
 - a. If 28VDC is not found on power box terminal strip, check wiring connections between junction box and power box.
 - b. If 28VDC is found on power box terminal strip, check terminal 36 on PLC for 28VDC.
5. If 28VDC is present on PLC input terminal but input light is not on and there is a door fault, PLC is malfunctioning.

Grain Column Over-Temperature Switch



Image 4-6 – Grain column over-temp switch

There are three grain column over-temperature switches on dryer. See locations in Fig. 3 and Table 1. These sensors monitor temperature in grain. Switch will turn dryer off if temperature reaches 240°F.



Fault Condition Column Over-Temp

Upper switch uses wires 84 & 85
Middle switch uses wires 82 & 83
Lower switch uses wires 80 & 81

Check all grain columns for obstructions that would prevent grain from flowing through. If an obstruction is found, do not restart dryer until it has been cleared.

NOTE: To check for an obstruction, go to Manual operation in QuadraTouch Pro and turn unload to ON. Run unload long enough for grain level in columns to drop at least 1 foot. Stand back from dryer and look through screens to observe grain level in each column. Any column with an obstruction will be readily visible.

1. If no obstructions are found and grain is flowing freely through each column, plenum temperature may need to be reduced.
2. If column temperature has cooled down and RESET button has been pressed on touch screen and fault message is still being displayed, remove junction box cover and check for 28VDC on wire 18.
 - a. If 28VDC is NOT detected, O/T sensor is defective.
 - b. If 28VDC is found on wire coming from O/T sensor but PLC input light is NOT on, note number of wire and go to power box and check for 28VDC on terminal strip.
 - c. If 28VDC is NOT found on terminal strip in power box, check wiring connections between junction box and power box.
 - d. If 28VDC is detected on terminal strip in power box, go to PLC and check for 28VDC on input terminal.
 - e. If 28VDC is detected on PLC input terminal, and input light is not on and fault message is still displayed (after pressing RESET), then PLC is malfunctioning.
3. Allow time for columns to cool down.
4. At this point, 28VDC should be present on wire 18 at O/T sensor.
Check for 28VDC on other wire (not 18) coming from sensor.

Blower Air Switch



Image 4-7 – Blower air switch

Air switch sensor monitors air flow at inlet of blower. Single-blower dryers have one air switch; three-blower dryers have three. They are located in main power box. Device will shut down dryer if there is not enough air flow. See Fig. 3 and Table 1 for location of sensor(s) on dryer.



Fault Condition No Static Air Pressure

Blower 1 uses wire 143
Blower 2 uses wire 243
Blower 3 uses wire 343
Blower 4 uses wire 443

1. For monitoring adequate air flow, blower(s) must be turned on.
2. Using Manual Operation, turn blower(s) ON. Check for proper operation and airflow.
3. If a fault message is displayed, switch may not be adjusted correctly.
 - a. Open power box.
 - b. With blower switch turned to ON, check PLC input light. It should be ON.
 - c. If input light is NOT on, check tubing for kinking and to ensure it is positioned to sense air flow into blower. Also check fittings on switch in power box to ensure tight connection. If fan is on and input light is still not on, use a straight screwdriver to turn adjustment screw counterclockwise until screw is up against c-ring.
 - d. Once input light is on, turn blower(s) off and observe PLC input light. Light should turn OFF as blower(s) slows down.
 - e. If light remains ON after blower(s) slow or stop, adjustment screw on switch should be turned clockwise until input light is off.
 - f. While watching PLC input, turn blower(s) ON and then OFF, ensuring input light is turning on and off with fan.
4. If, after going through above procedure, PLC input light remains in either ON or OFF position without changing, voltage measurements will be necessary.
 - a. Locate wire 18 in junction box and check for 28VDC.
 - b. If 28VDC is NOT found, go to power box and check for 28VDC on terminal strip.
 - c. If 28VDC is found on terminal strip, go to PLC and check for 28VDC.
 - d. If 28VDC is found on this wire, use a small screwdriver and turn screw clockwise until 28VDC is not present.
 - e. If turning adjustment screw clockwise fails to turn air switch OFF, then switch is defective.
 - f. If 28VDC is NOT found on wire coming from switch, use a small screwdriver to turn screw counterclockwise until 28VDC is detected.
 - g. If turning adjustment screw counterclockwise fails to turn air switch ON, then switch is defective.
5. After replacing blower switch, follow previous instructions on switch adjustment for proper operation.
 - a. If PLC input light is not turning on when switch is on, check voltage.
 - b. Adjust switch to ON position. Check for 28VDC on wire coming from switch.
 - c. Take note of wire number and go to power box. Check for 28VDC on terminal strip.
 - d. If 28VDC is NOT found on terminal strip, check wiring connections between junction box and power box terminal strip.
 - e. If 28VDC is found on terminal strip, go to PLC input terminal and check for 28VDC.
 - f. If 28VDC is NOT found on input terminal, check wiring connections between terminal strip and PLC.
 - g. If 28VDC is found on PLC input terminal but input light is not on and fault message is still being displayed after pressing RESET, PLC is malfunctioning.

Plenum Over-Temperature Switch



Image 4-8 – Plenum over-temp switch.

Plenum over-temp switch is located inside plenum of dryer. See Fig. 3 and Table 1 for location(s). It is provided to protect plenum from overheating.



Fault Condition **Plenum Over-Temp**

Switch uses wire 39

1. With dryer shut down, open door and inspect plenum for any problems.
2. After plenum has cooled down, press RESET and fault should be cleared. **NOTE:** Switch will reset automatically when temperature drops below 325°.
3. If fault has not cleared, remove cover from junction box containing plenum O/T switch and check for 28VDC on wire 18.
4. If 28VDC is NOT detected, check connection with terminal 18 in power box.
5. Check for 28VDC on other side of switch.
 - a. If O/T switch has cooled down below 325° and 28VDC is NOT found on other wire, then switch is defective.
 - b. If 28VDC is found on other wire coming from switch, go to PLC and check input light. If input light is ON, press RESET and fault should clear.
 - c. If input light is not ON, take note of number of wire coming out of O/T switch. Go to power box and check for 28VDC on terminal strip.
 - d. If 28VDC is NOT found on power box terminal strip, check wiring connections between junction box and power box.
 - e. If 28VDC is found on power box terminal strip, check for 28VDC on PLC input terminal.
 - f. If 28VDC is found on PLC terminal and input light is OFF and fault message is still displayed, PLC is malfunctioning.

Incoming/Discharge Moisture Sensors



Image 4-9 – Incoming moisture sensor

See Fig. 3 and Table 1 for locations of incoming and discharge moisture sensors. They monitor moisture and temperature of grain as it enters and is discharged from dryer.



Input Sensor Not Found

If “Input Sensor Not Found” screen appears on touch screen, it means that at least one analog input sensor is missing from PLC. Follow quick-reference moisture sensor troubleshooting steps at bottom of Page 2. If problem persists, follow steps below.

NOTE: Color of moisture sensor cable may be different than shown.

1. Using a screwdriver, remove cover on junction box near incoming moisture sensor.
2. The four (4) wires used by moisture sensor are white (ground), brown (28V power supply), blue (return voltage for temperature), & black (return voltage for moisture).
3. Using a voltage meter, check for 28VDC voltage between brown (terminal 18) and white (terminal 95). If 0VDC is found, check connections between junction box and main power box. Repair any faulty connection(s) and retest.
4. If brown wire has 28VDC, check for DC voltage between black and white wires in junction box. Something between 1 and 10VDC should be detected. If 0VDC is found, incoming moisture sensor is malfunctioning and must be replaced.
5. If correct signal is present in junction box, check to see if this voltage can be found in main power box on D5 terminal. If voltage is not present on D5 terminal, check upstream connections in main power box. Repair any faulty connection(s) and retest.
6. If same voltage is found on D5 terminal in power box as in junction box, check between D5 terminal on PLC and 95. If 0VDC is found, there is a connection problem between power box terminal strip and PLC. If same voltage (1-10VDC) is present on PLC D5 input as junction box, the green analog input PLC card may be malfunctioning.
7. Blue wire is labeled D3 on power box terminal strip. This is the temperature signal. If voltage between 0VDC to 3.0VDC is not found, sensor is malfunctioning and must be replaced (0.70V = 70° F.)
8. Cable from discharge moisture sensor runs straight to main power box. Its black wire connects to D4 terminal. Follow steps above as applicable to check voltages.

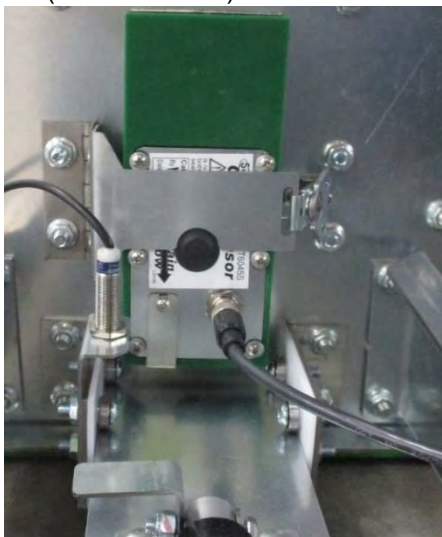

Image 4-10 – Disch. moisture sensor

QuadraTouch Pro Controller

If connection between QuadraTouch Pro panel and PLC is lost, Communication Error screen will appear.

Fixing a Communication Error

Make sure touch-screen and PLC are both ON.

- On main power box, make sure E-Stop is pulled out and illuminated RED, and that System Control Switch is on QuadraTouch Pro. Make sure PLC lights are on.
- Check link lights on Ethernet ports of both QuadraTouch Pro console and PLC. To check on console, loosen knurled thumb screws below touch-screen and lift screen. Ethernet cable should be plugged into the “X2 ETH” port.
- If one link light is illuminated on either the X2 ETH port or PLC, Ethernet cable should be good.
- If one of the Ethernet couplers is bad, both link lights will be off.
- If link light is lit on one device (PLC or console) but not the other, use a cable known to be good and connect the device with no link light to a laptop computer. If no light illuminates, Ethernet port on checked device (PLC or console) is likely bad.

Checking Communications Settings on QuadraTouch Pro

- Ensure that Ethernet cable connecting dryer to QuadraTouch Pro console is plugged into port “X2 ETH” and that link lights are on in both the PLC and touch-screen console.
- If another cable is plugged into “X3 ETH,” unplug it and reconnect after the communication error has been resolved.
- Go to Tools → Connectivity Tools → Communication Tools → Network Repair Utility → Start Network Repair. This will reset the touch-screen console’s Ethernet ports to factory settings.
- After process is complete, press Reset to return to main page.

Plenum/Grain Column Temperature Sensor RTD & Transmitter

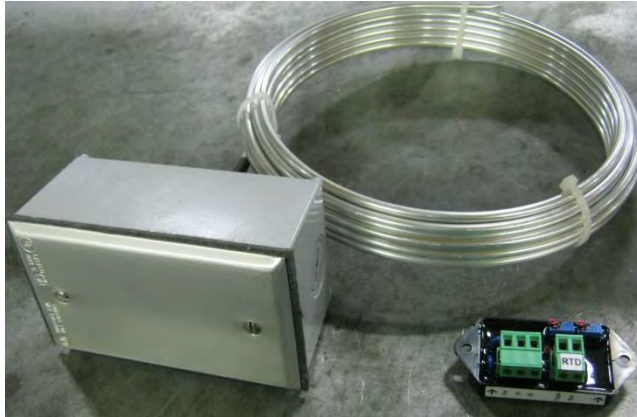

Image 4-11 – Plenum temperature sensor RTD and transmitter

Plenum and grain column temperature sensors consist of RTD (Resistance Temperature Detector) and transmitter. See Fig. 3 and Table 1 for locations of plenum and column temperature sensors.

RTD measures average resistance over length of tube. Dryers use 24' or 28' tube lengths, and four single-point RTDs.

RTD is used with a transmitter that converts resistance into a 1 to 5 VDC signal. This voltage is then fed into PLC and displayed on QuadraTouch Pro screen.

- If RTD is in question, a voltage and resistance comparison can be made to determine if unit is defective.
1. Begin by locating transmitter in main power box. See Images 4 and 5 in Component Identification section of this manual. Each RTD transmitter is in a black potting tray. A white label should be attached to each transmitter labeling one as “Plenum RTD” and other as “Column RTD”. **IMPORTANT:** Above two-pin terminal block are two small adjustment screws. NEVER adjust either of these screws. If moved, transmitter will not work correctly until a factory calibration is performed.
 2. On three-pin terminal strip, check for 28VDC on terminals 18 and 95.
 3. With 28VDC present at plenum transmitter, check output voltage (71 and 95). Voltage between 1.0VDC and 5.0VDC should be found. **NOTE:** Respective terminals on column transmitter are 70 and 95. Use same testing process as for plenum transmitter.

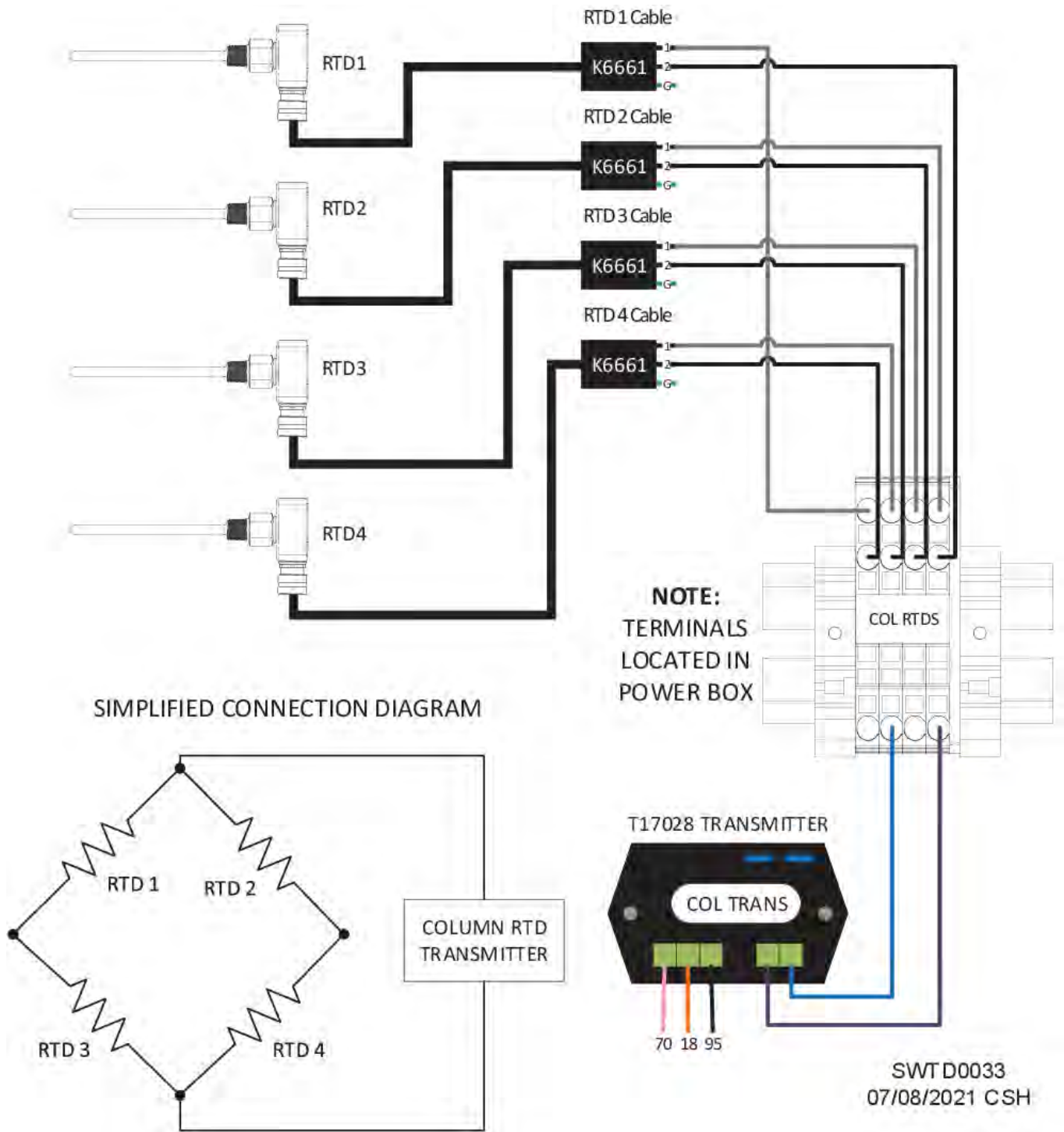

Image 4-12 – Single-point grain column temperature sensor

4. With 28VDC on terminals 18 and 95 but no voltage between terminals 71 and 95, transmitter is defective.
5. If voltage is detected, use table on next page to determine if equivalent temperature is reasonable.
6. If voltage is detected between terminals 71 and 95, go to other terminal strip and remove two wires coming from RTD (both pink).
7. Take a resistance reading with meter. Resistance of RTD is directly related to temperature of RTD. **NOTE:** This reading should be between 900 and 1,500 Ohms. Compare resistance reading to table on next page to determine if resistance is reasonable.
8. If resistance is not within range, disconnect RTD cables from column RTD terminals (See drawing on Page 4-13) and check resistance of each. Readings should be between 900 and 1,500 Ohms. Sensors not in this range must be replaced.
9. If reading shows infinite (open) resistance, RTD is defective.
10. If resistance compares to ambient temperature around dryer, and voltage on output wire is close to ambient temperature, then transmitter and RTD are functioning correctly.

TEMPERATURE (°F)	RESISTANCE (1,000 OHM) OF PLENUM RTD	RESISTANCE (100 OHM) OF SINGLE-POINT COLUMN RTD	VOLTAGE
10	952	95.2	1.16
15	963	96.3	1.24
20	974	97.4	1.32
25	984	98.4	1.40
30	995	99.5	1.48
35	1006	100.6	1.56
40	1017	101.7	1.64
45	1028	102.8	1.72
50	1039	103.9	1.80
55	1049	104.9	1.88
60	1060	106.0	1.96
65	1071	107.1	2.04
70	1082	108.2	2.12
75	1093	109.3	2.20
80	1103	110.3	2.28
85	1114	111.4	2.36
90	1125	112.5	2.44
95	1136	113.6	2.52
100	1146	114.6	2.60
105	1157	115.7	2.68
110	1168	116.8	2.76
115	1178	117.8	2.84
120	1189	118.9	2.92
125	1200	120.0	3.00
130	1211	121.1	3.08
135	1221	122.1	3.16
140	1232	123.2	3.24
145	1243	124.3	3.32
150	1253	125.3	3.40
155	1264	126.4	3.48
160	1275	127.5	3.56
165	1285	128.5	3.64
170	1296	129.6	3.72
175	1306	130.6	3.80
180	1317	131.7	3.88
185	1328	132.8	3.96
190	1338	133.8	4.04
195	1349	134.9	4.12
200	1359	135.9	4.20
205	1370	137.0	4.28
210	1380	138.0	4.36
215	1391	139.1	4.44
220	1402	140.2	4.52
225	1412	141.2	4.60
230	1422	142.2	4.68
235	1433	143.3	4.76
240	1443	144.3	4.84
245	1454	145.4	4.92
250	1464	146.4	5.00

Diagram below shows wiring of four single-point column RTD sensors to column RTD transmitter.





QuadraTouch Pro™ Software Manual

Control System for Cross-Flow (Axial/Centrifugal), Mixed-Flow & Tower Dryers



Software changes often. To obtain the latest version, download at:

<http://www.sukup.com/Products/QuadraTouch>

TABLE OF CONTENTS

Settings

Load Settings -----	4
Load Delay Timers -----	5
Load Aux. Timer Delays -----	5
Setting Dryer Fill Type -----	5
Out of Wet Grain Timer -----	6
Fill Timer -----	6
Fan/Heat Settings -----	6
Fan Start Delay Timer -----	7
Fan Shutdown Delay Timer -----	7
Air Switch Timer -----	7
Heat Delay Timer -----	7
Flame Out Timer -----	8
Plenum Temperature -----	8
Plenum Min/Max Limits -----	8
Auto Temp Adjust -----	8
Low Temp Option -----	9
High Temp Option -----	9
Plenum Out of Range Shutdown -----	9
EMOV Settings -----	9
LP Vaporizer Warmup -----	10
EMOV Loop Controls -----	10
Unload Settings -----	11
Meter Roll Min/Max Limits -----	11
Meter Roll Delay Timer -----	11
Unload Type Selection -----	12
Moisture Gain -----	12
Moisture Deadband -----	12
Unload Speed Loop Controls -----	12
Temperature Gain -----	13
Temperature Deadband -----	13
Unload Start Delay Timer -----	13
Unload Auxiliary Timers -----	13
Unload Pause Delay Timer -----	14
Unload Cleanout Timer -----	14
Grain Settings -----	14
Discharge Moisture Alarm -----	15
Moisture Sensor Configuration -----	15
Grain Type Selection -----	15
Air System Settings -----	16
Configure User Fault Text -----	16
Configure Aux Input -----	16
Fault Horn -----	16

Tools

Calibrate Sensors -----	17
Discharge Moisture Sensors -----	17

Bushel Counter -----	18
Automatic Calibration -----	18
Manual Calibration -----	18
Discharge Temp Calibration -----	19
Plenum Calibration -----	19
Plenum Temp Calibration -----	19
Input Moisture Sensor -----	19
Column RTD Calibrations -----	20
History Log -----	20
Language -----	20
Connectivity Tools -----	20
Get Current Public IP -----	21
Remote Access -----	21
GSM Options -----	21
GSM Diagnostics -----	22
Check Communications -----	22
Network Repair Utility -----	22
Graphs -----	22
Build Your Own Graph -----	23
System Tools -----	23
System Information -----	23
Time/Date -----	23
Dryer Type Selection -----	24
Data Backup/Transfer to USB -----	24
Lock-Out Code -----	24
Launch On-Screen Keyboard -----	24
Restricted Area -----	25
Other System Tools -----	25
Diagnostic Tools -----	25
Show/Hide Output Window -----	25
PLC Inputs/Outputs Diagnostics -----	26
Analog System Diagnostics -----	26
Plenum Diagnostics -----	26
PLC Bus Diagnostics -----	27
Master Diagnostic Bit View -----	27
PLC Bus View -----	27
Reload Main Script -----	27
Manuals/Wiring Diagrams -----	28
Worklight Override -----	28
Shutdown Tools -----	29
Timer Shutdown -----	29
Discharge Moisture Alarm -----	29
Alarm Clock Shutdown -----	29
Plenum Out-of-Range Shutdown -----	30
Bushel Timer Shutdown -----	30
Utility Tools -----	30
Air System Control -----	30
Update Tools -----	31

QuadraTouch Update -----	31
PLC Program Choices -----	31
Update Moisture Version -----	31
Other Updates -----	32
Load System Override -----	32
Tower Cold Start Fan Override -----	32

Cross-Flow/Mixed-Flow Operation

Continuous Flow (Automatic) -----	33
Initial Dry Settings -----	33
Starting Initial Dry -----	33
Restart with Stabilization -----	34
Fan/Heat Control -----	34
Stabilization/Restart -----	34
Stabilization Speed Selection -----	34
Dry Fire -----	35
Final Dry -----	35
Auto Batch -----	36
Manual Operation -----	38
Plenum Temp Setpoint -----	38
Discharge Moisture Setpoint -----	38
Switching to Automatic Operation -----	38
Resetting Plenum Details -----	39
Resetting Unload Speed Limits -----	39

Resetting to QuadraTouch Pro Home Page

Fan/Model Selection

Cross-Flow Models -----	40
Tower Dryers -----	40
Mixed-Flow Dryers -----	41

Tower Dryer Operation

Start Menu - Burner Tarp Removed? -----	42
Choosing Control Method -----	42
Automatic Operation -----	42
Moisture vs. Temp Control -----	43
Manual Operation -----	43
Load, Unload, Fan(s), Heat -----	43
Countdown Timers Displayed -----	43

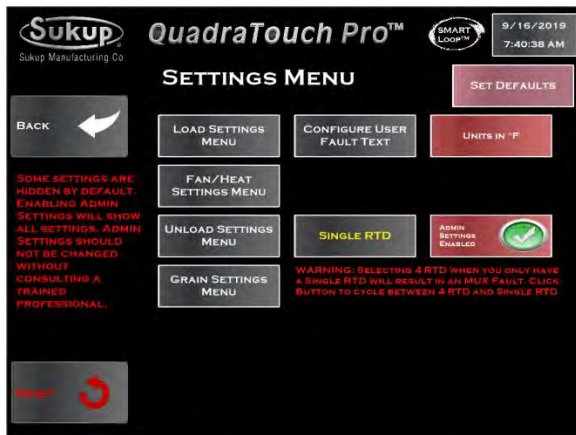

Settings

Cross-Flow/Mixed-Flow

Settings Menu for cross-flow and mixed-flow dryers shows most drying settings that are commonly used during operation.

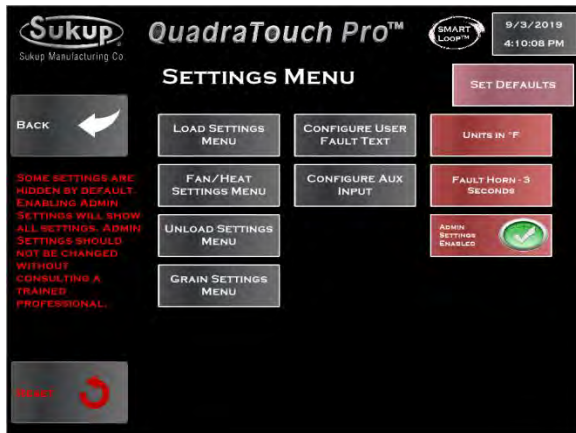

Tower

Settings Menu for tower dryers shows most drying settings that are commonly used during operation.

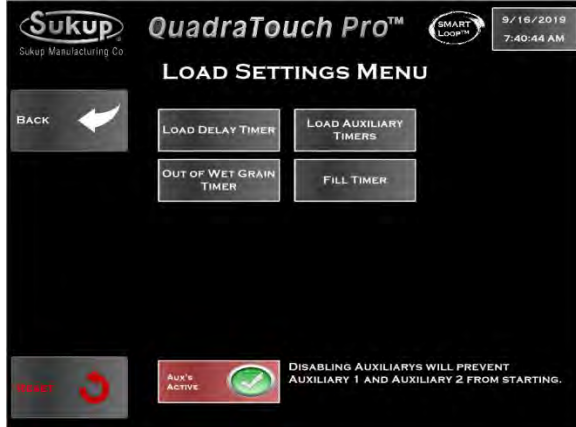

Load Settings

Cross-Flow/Mixed-Flow

Settings → Load Settings Menu

Load Settings Menu for cross-flow and mixed-flow dryers provides access to set load timers and to enable load auxiliaries.

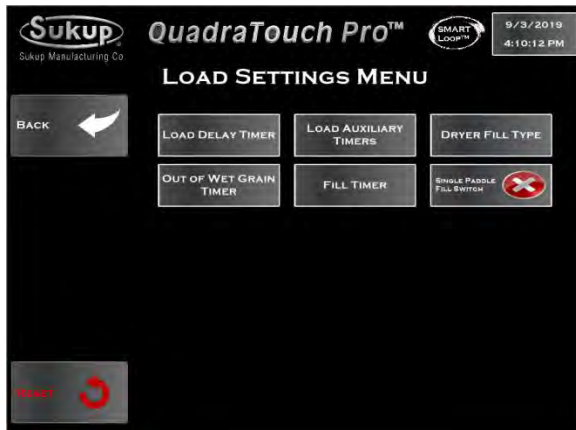

Tower

Settings → Load Settings Menu

Load Settings Menu for tower dryers provides access to set load timers, dryer fill type, and extended wet bin dual paddle switch operation.

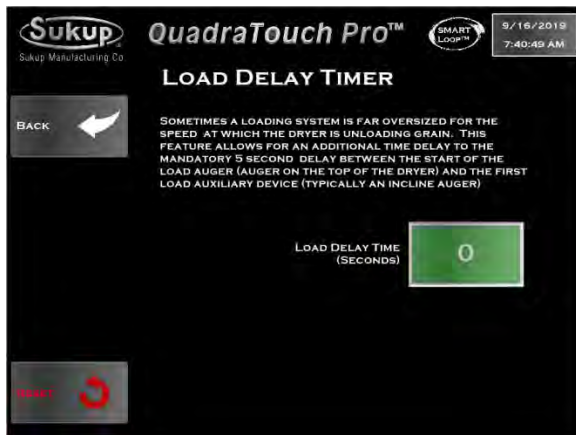

All Dryers

Settings → Load Settings Menu → Load Delay Timer

Set Load Delay Timer to prevent overload from auxiliary equipment starting too often.

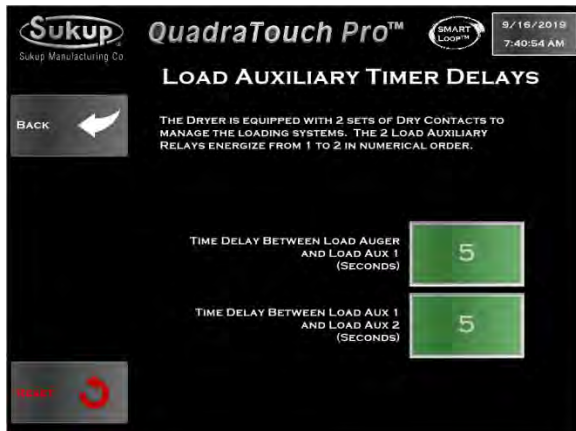

Cross-Flow/Mixed-Flow

Settings → Load Settings Menu → Load Auxiliary Timers

Time delays between load auxiliaries for cross-flow and mixed-flow dryers can be set here.

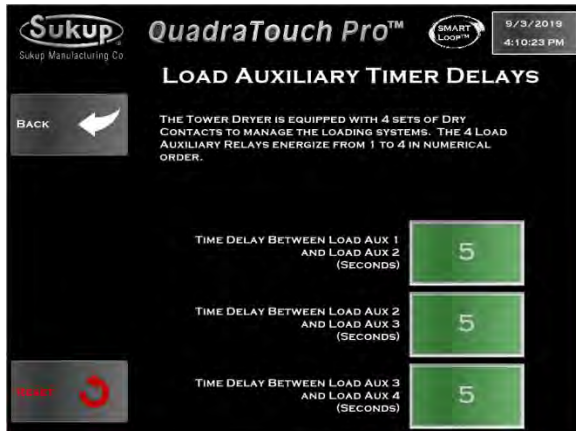

Tower

Settings → Load Settings Menu → Load Auxiliary Timers

Time delays between load auxiliaries for tower dryers can be set here.

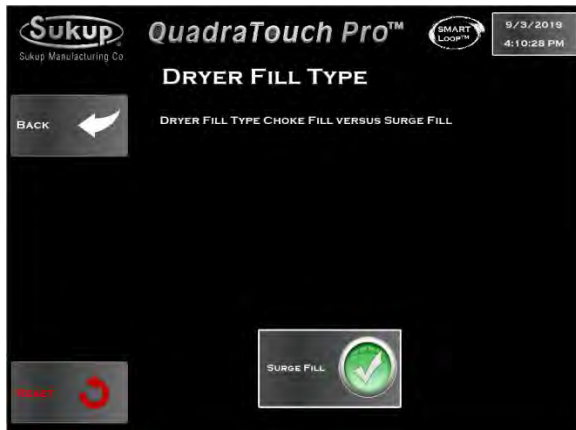

Tower

Settings → Load Settings Menu → Dryer Fill Type

Set dryer fill type (choke-fill vs. surge-fill) here for tower dryers.

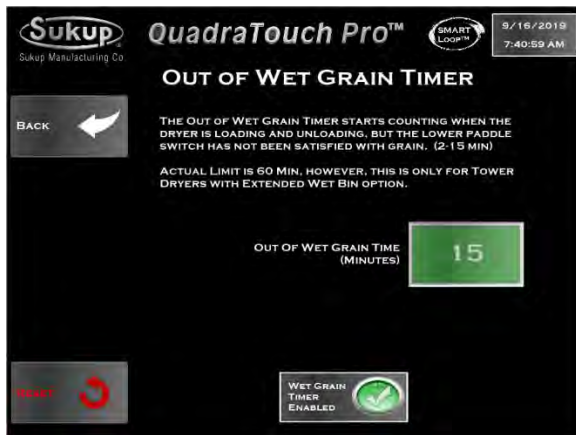

All Dryers

Settings → Load Settings Menu → Out of Wet Grain Timer

This timer begins counting when dryer is calling for more grain and will trigger a fault condition if dryer fill switch is not satisfied within user-set period of time.



All Dryers

Settings → Load Settings Menu → Fill Timer

This timer counts when fill switch senses grain. Timer resets when dryer calls for grain. It will trigger a fault message when user-set time expires if dryer has not called for grain.

NOTE: Dryers without fill augers use single rotary fill switches.

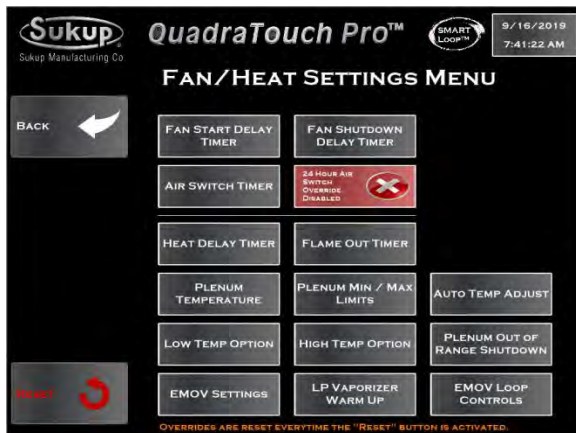

Fan/Heat Settings

Cross-Flow/Mixed-Flow

Settings → Fan/Heat Settings Menu

Fan/Heat Settings Menu for cross-flow and mixed-flow dryers shows settings associated with fans and heaters on dryer.

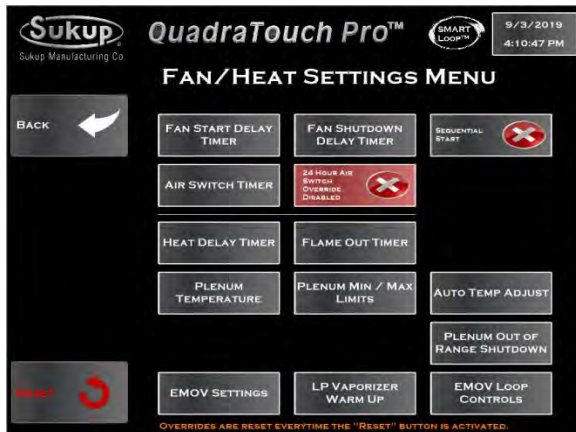

Tower

Settings → Fan/Heat Settings Menu

Fan/Heat Settings Menu for tower dryers shows settings associated with fans and heaters.



All Dryers

Settings → Fan/Heat Settings → Fan Start Delay Timer

This setting dictates amount of time between fan starts on all dryers. A longer delay may be a good idea if power is limited or motor current draws are very high.



All Dryers

Settings → Fan/Heat Settings → Fan Shutdown Delay Timer

In addition to standard 3-second fan shutdown delay, additional time can be added to cool off grain when stopping operation or to stop fault shutdowns that aren't related to temperature or safety.

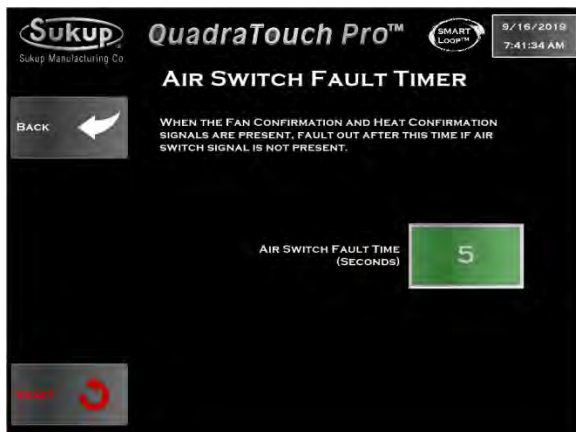

All Dryers

Settings → Fan/Heat Settings → Air Switch Timer

Air switch must sense pressure within a user-set number of seconds of fan contactor closing. With a Soft Start, air switch is given until fan reaches run state. If fan doesn't get up to speed during that amount of time, this timer can be adjusted to allow for longer ramp time.

There is a 24-Hour Air Switch Override that resets every time user presses Reset button. This allows continued operation while user waits for parts, for example.

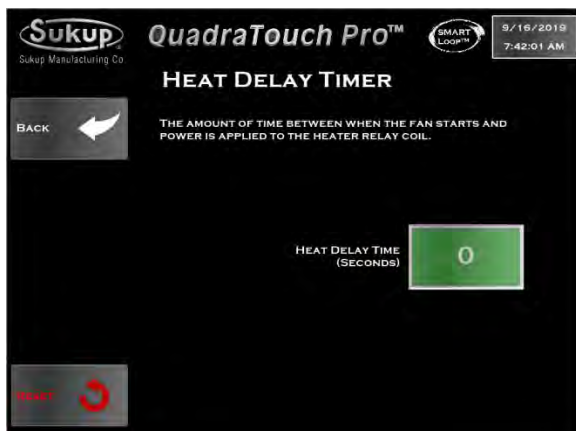

All Dryers

Settings → Fan/Heat Settings → Heat Delay Timer

Set delay time between fan start and power signal to heater box. This is in addition to required minimum time.

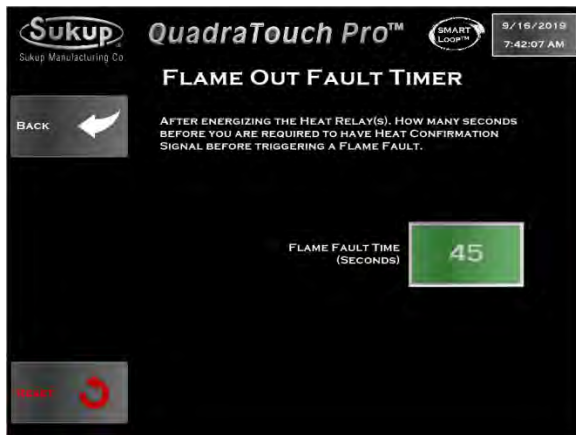

All Dryers

Settings → Fan/Heat Settings → Flame Out Timer

A longer flame fault time may be needed if heater ignition isn't occurring before the time entered. Applies to LME69, LME71, & LME73 controllers which require manual reset.



All Dryers

Settings → Fan/Heat Settings → Plenum Temperature

Plenum Temperature page is starting point to set temperatures for each plenum. There is one plenum on a tower dryer. Temperatures for up to six plenums can be set for other dryers.

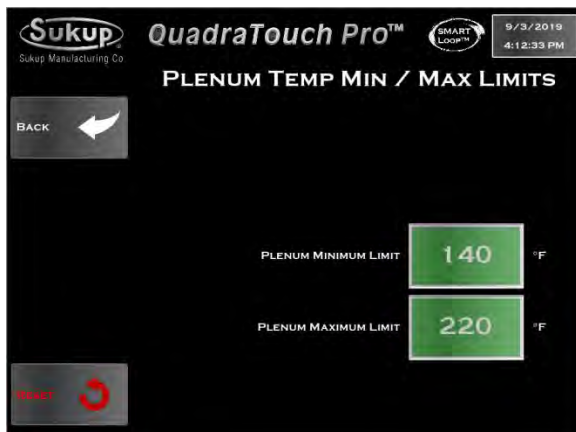

All Dryers

Settings → Fan/Heat Settings → Plenum Min/Max Limits

Minimum and maximum plenum temperatures can be found here. Low temp/high temp option can allow for larger value ranges.

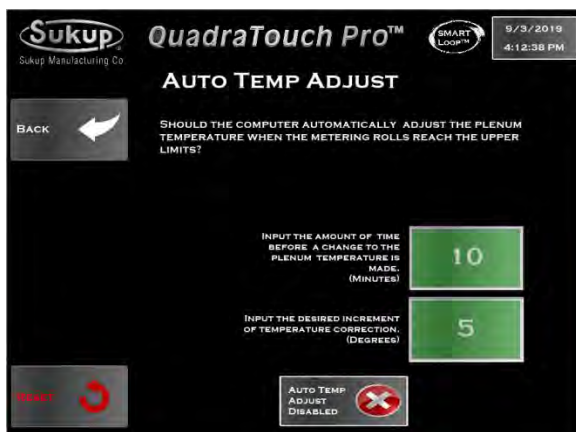

All Dryers

Settings → Fan/Heat Settings → Auto Temp Adjust

If enabled, this feature will turn down temperature inside plenum(s) when dryer reaches its upper speed limit.



Cross-Flow/Mixed-Flow

Cross-Flow/Mixed-Flow

Settings → Fan/Heat Settings → Low Temp Option

If enabled on cross-flow or mixed-flow dryer, Low Temp Option allows plenum temp to be set as low as 100°F. Permanent damage may result if a low-temp kit (orifice and port cup) is not installed in starfire burner used with 28" axial fan.



Cross-Flow/Mixed-Flow

Settings → Fan/Heat Settings → High Temp Option

If enabled on cross-flow or mixed-flow dryer, High Temp Option allows plenum temp to be set above 220°F. Drying at temperatures above 220°F increases chance of having a fire in dryer and of having plenum and column over-temp faults.

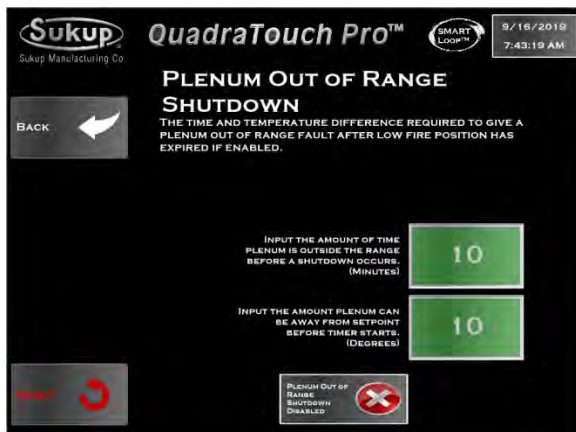

All Dryers

Settings → Fan/Heat Settings → Plenum Out of Range Shutdown

Use this feature to set amount of time and/or temperature that plenum temperature can be out of range/off of setpoint.

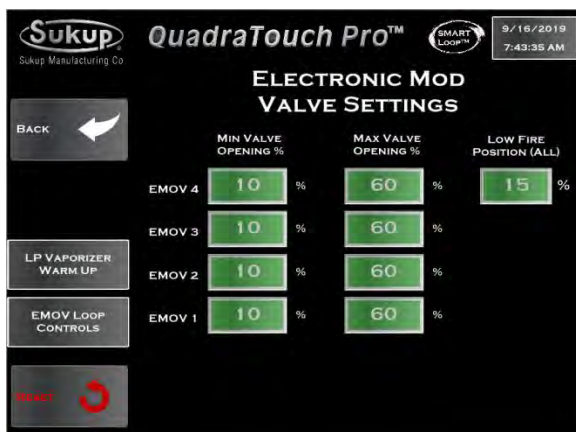

All Dryers

Settings → Fan/Heat Settings → EMOV Settings

Electronic mod valve settings generally do not need to be touched, but can be if needed. Minimum opening should be 10% for all. Maximum opening should be 80-100% on tower dryers and 60% for all others. Low Fire Position is the percentage that valve stem will be open when heater ignition takes place.



All Dryers

Settings → Fan/Heat Settings → EMOV Settings → LP Vaporizer Warmup

Amount of time that EMOV will stay open in Low-Fire position after lighting can be adjusted to give vaporizer more time to warm up. Default time is 20 seconds for all dryers.

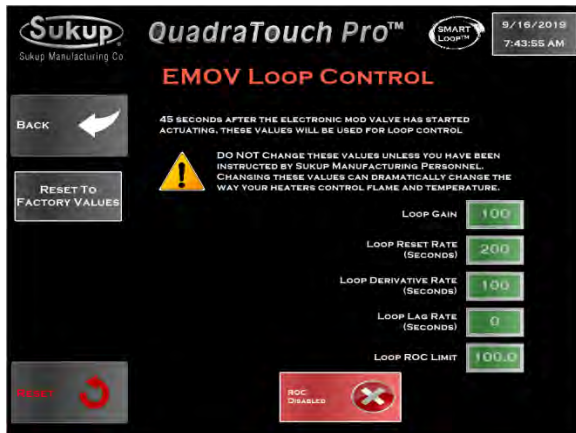

All Dryers

Settings → Fan/Heat Settings → EMOV Settings → EMOV Loop Controls

On all dryers, 45 seconds after EMOV actuation has begun, values shown in screen at left will be used for SMART Loop control of dryer. DO NOT CHANGE unless instructed to do so by Sukup Manufacturing Co.

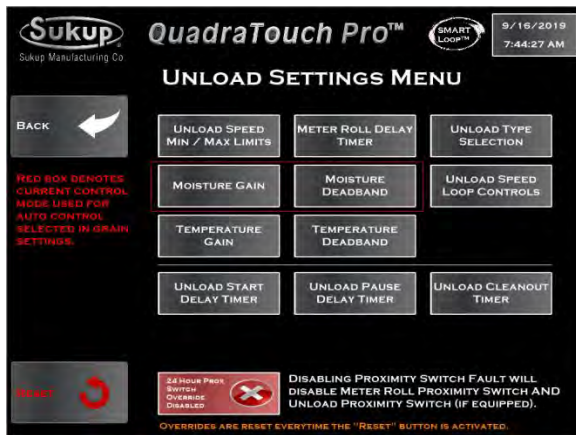

Unload Settings

Cross-Flow/Mixed-Flow

Settings → Unload Settings Menu

Unload Settings Menu for cross-flow and mixed-flow dryers shows settings that are commonly used during operation.

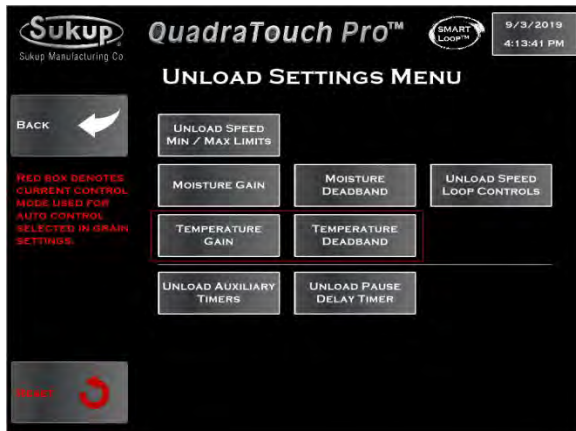

Tower

Settings → Unload Settings Menu

Unload Settings Menu for tower dryer shows settings that are commonly used during operation.

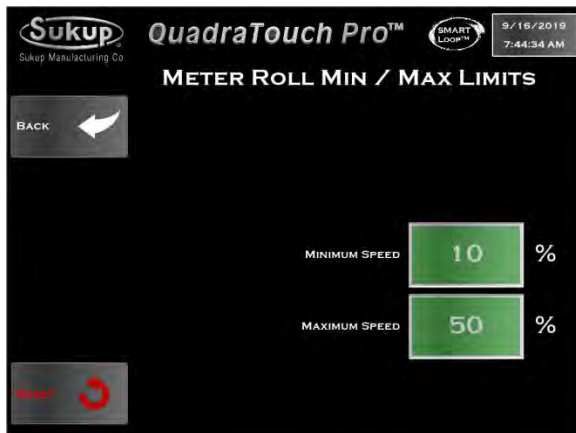

All Dryers

Settings → Unload Settings Menu → Meter Roll Min/Max Limits

Press Unload Speed Min / Max button shown on previous screen to set Meter Roll Min / Max Limits. Minimum and maximum settings dictate how fast or slow dryer is capable of running. Never unload faster than take-away system is capable of running.

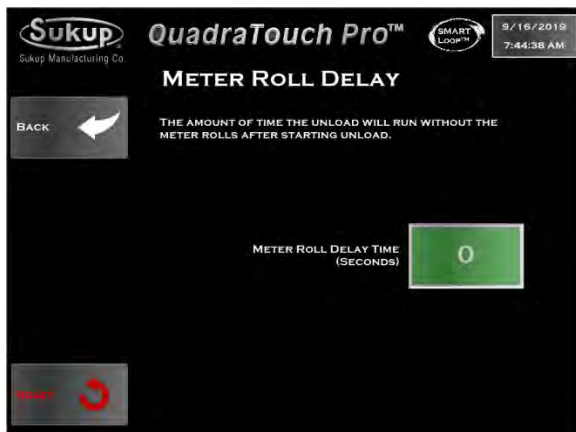

Cross-Flow/Mixed-Flow

Settings → Unload Settings Menu → Meter Roll Delay Timer

Set amount of time that unload system will run without meter rolls after starting of unload system.

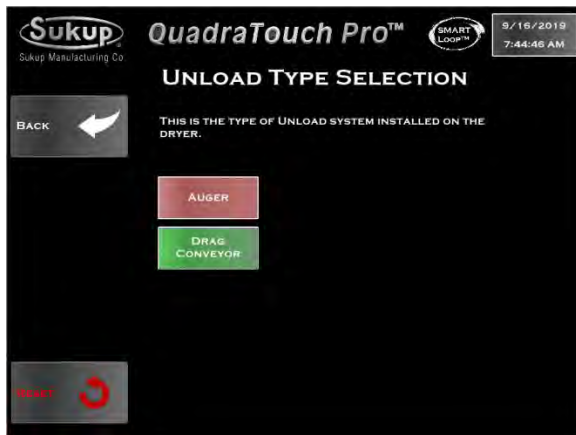

Cross-Flow/Mixed-Flow

Settings → Unload Settings Menu → Unload Type Selection

Select type of unload system – Auger or conveyor.

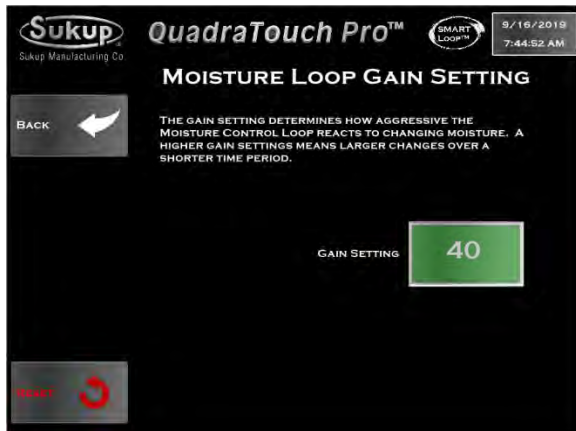

All Dryers

Settings → Unload Settings Menu → Moisture Gain

Moisture Loop Gain settings are important for optimum operation when discharging based on moisture. Choosing a higher setting will mean more aggressive changes in a shorter amount of time. When dryer is running at slower speeds, this number should stay around 40 or so. Conversely, at higher speeds, it may yield better control to boost this setting higher.

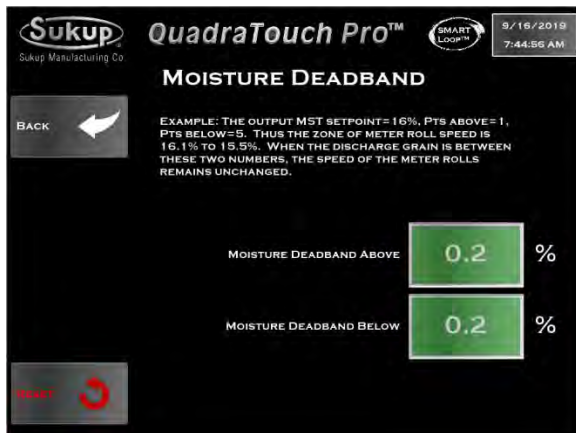

All Dryers

Settings → Unload Settings Menu → Moisture Deadband

For some systems, it may be preferable to lock in the unload speed when grain is discharging very near the target setpoint. This is referred to as the loop deadband.

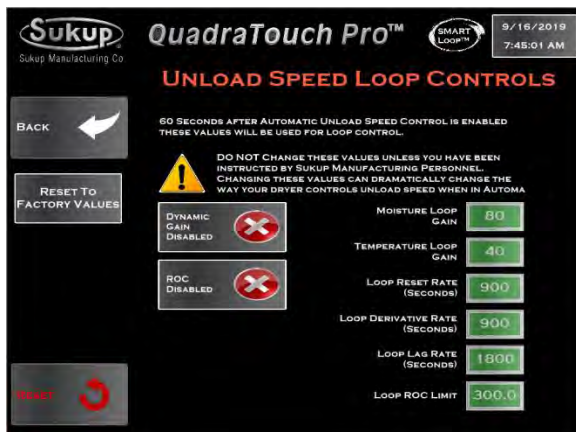

All Dryers

Settings → Unload Settings Menu → Unload Speed Loop Controls

Sixty seconds after Automatic Unload Speed Controls is enabled, these values will be used for SMART Loop control. DO NOT change unless instructed to do so by Sukup Manufacturing Co.

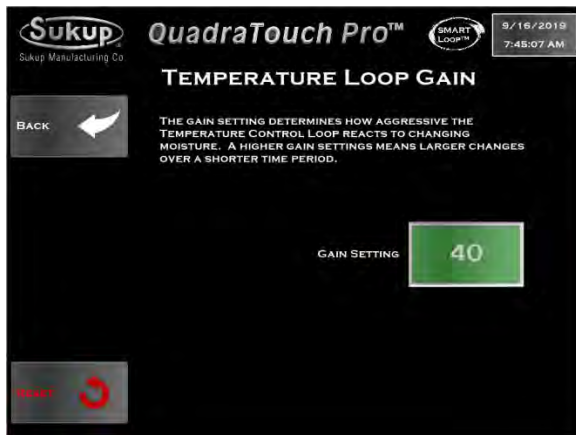

All Dryers

Settings → Unload Settings Menu → Temperature Gain

Temperature Gain settings are important for optimum operation when discharging based on temperature. Choosing a higher setting will mean more aggressive changes in a shorter amount of time. When dryer is running at slower speeds, this number should stay around 40 or so. Conversely, at higher speeds, it may yield better control to boost this setting higher.

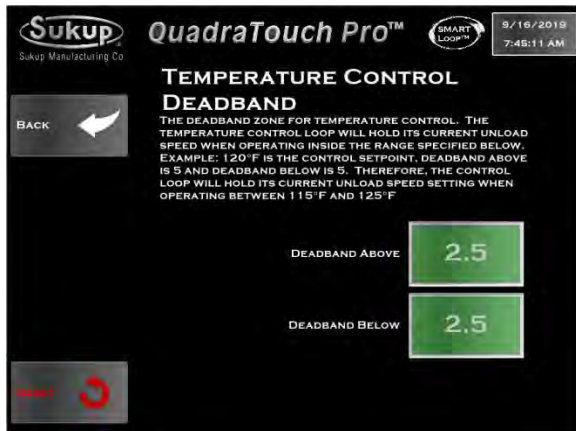

All Dryers

Settings → Unload Settings Menu → Temperature Deadband

For some systems, it may be preferable to lock in the unload speed when grain is discharging very near the target setpoint. This is referred to as the loop deadband.



Cross-Flow/Mixed-Flow

Settings → Unload Settings Menu → Unload Start Delay Timer

Set length of delay between point at which dryer is ready to start and point at which unload system starts.

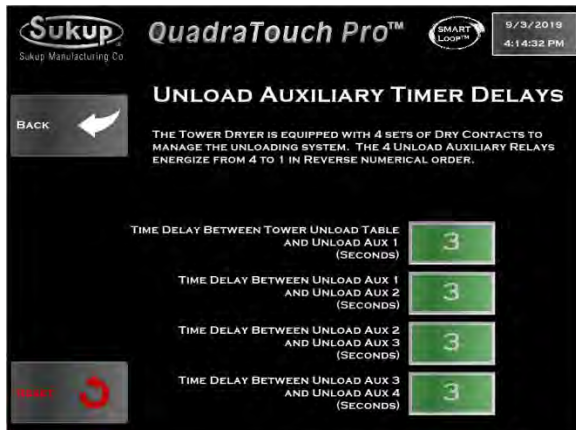

Tower

Settings → Unload Settings Menu → Unload Auxiliary Timers

Time delays between unload auxiliaries can be programmed here.

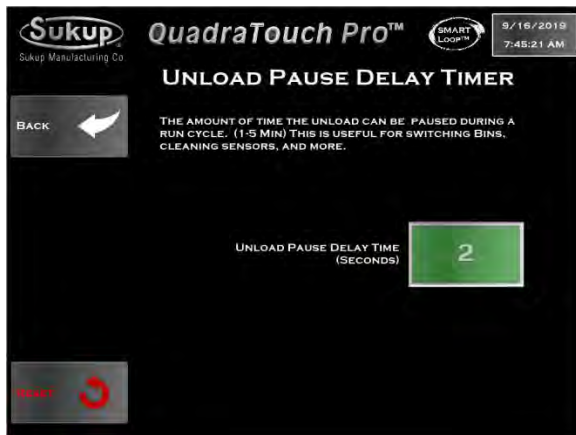

All Dryers

Settings → Unload Settings Menu → Unload Pause Delay Timer

Set amount of time that unload can be paused during a run cycle (1 to 5 minutes). This is useful for cleaning sensors and switching bins.



Cross-Flow/Mixed-Flow

Settings → Unload Settings Menu → Unload Cleanout Timer

If desired, set additional time for unload system to run after a standard shutdown. It provides time for unload system to clean itself out before shutting down. **NOTE:** Applicable only to dryers with unload augers, not those with conveyors.

Proximity Switch Override may be used to troubleshoot a faulty Proximity Switch or allow temporary continued operation while waiting for a part, for example.

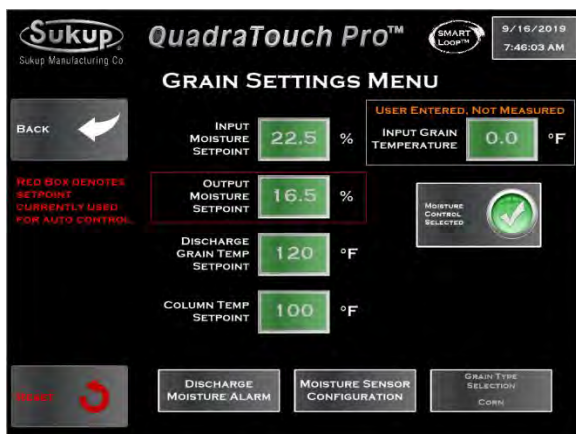

Grain Settings

All Dryers

Settings → Grain Settings Menu

Enter moisture content and temperature of incoming grain, and desired output moisture content and temperature, as well as column temperature setpoint. **NOTE:** Discharge Grain Temp not available on Tower Dryers

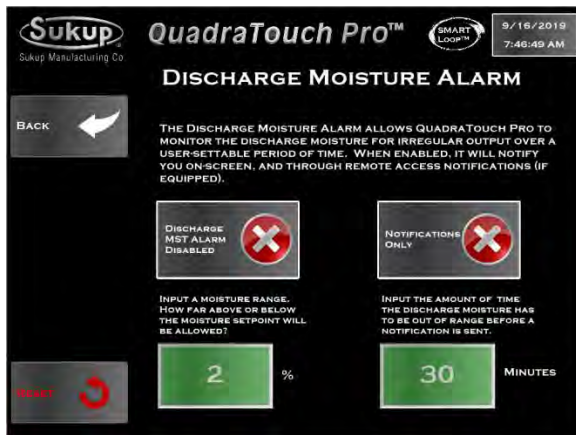

All Dryers

Settings → Grain Settings Menu → Discharge Moisture Alarm

When enabled, this feature will send notification if discharge moisture sensor detects irregular output for a user-set amount of time. Range of acceptable moisture can also be set.

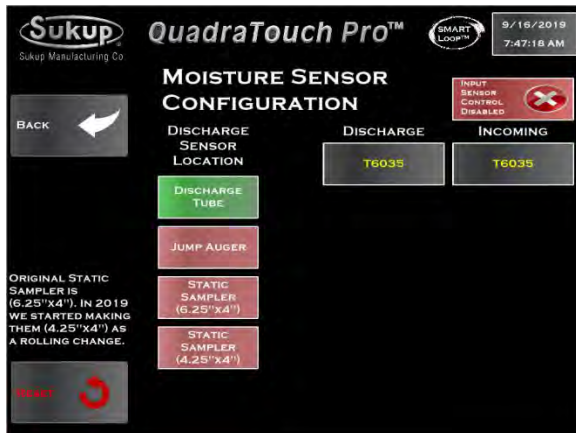

Cross-Flow/Mixed-Flow

Settings → Grain Settings Menu → Moisture Sensor Configuration

Dryer's moisture sensor(s) are configured here. Enter type and location of each sensor; recalibrate each; set sample frequency.

Enable 24 Hour MST Prox Override to allow for operation in manual mode only while waiting on parts, for example.

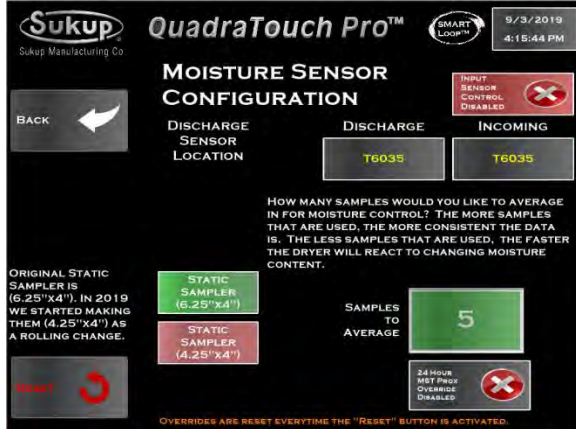

Tower

Settings → Grain Settings Menu → Moisture Sensor Configuration

Dryer's moisture sensor(s) are configured here. Enter type and location of each sensor; recalibrate each; set sample frequency

Enable 24 Hour MST Prox Override to allow for operation in manual mode only while waiting on parts, for example..

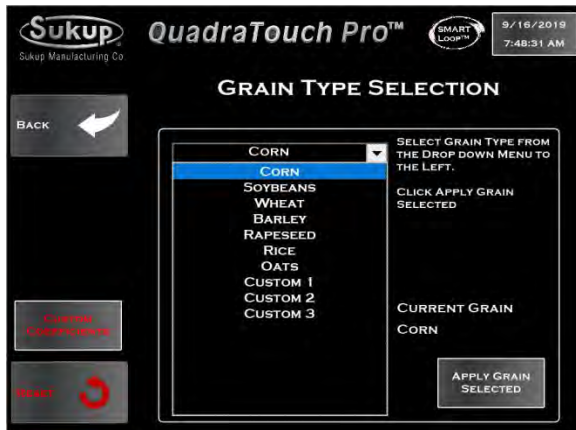

All Dryers

Settings → Grain Settings Menu → Grain Type Selection

Enter type of grain that is to be dried. Note that changing grain type, temperature measurement scale, or discharge moisture sensor type or location will remove configuration of moisture sensor.

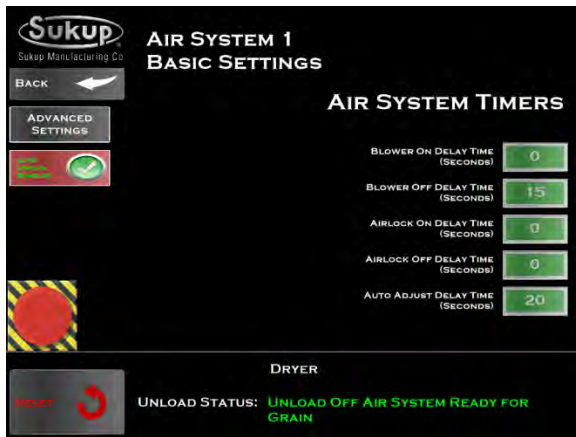

Air System Settings

Cross-Flow/Mixed-Flow

Settings → Air System Settings

If using air system with dryer, set operating parameters for each. See Cyclone Installation & Operation Manual, L1396.



Configure User Fault Text

All Dryers

Settings → Configure User Fault Text

If desired, change User Fault message wording.

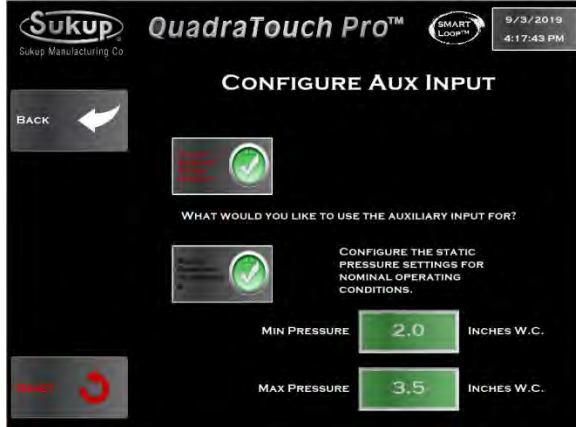

Configure Aux Input

Tower Dryer

Settings → Configure Aux Input

Analog input can be configured for an additional temperature sensor or static air pressure sensor.

Fault Horn

Tower Dryer

Settings → Fault Horn

Fault horn can be set to sound for 3 seconds or continuously.

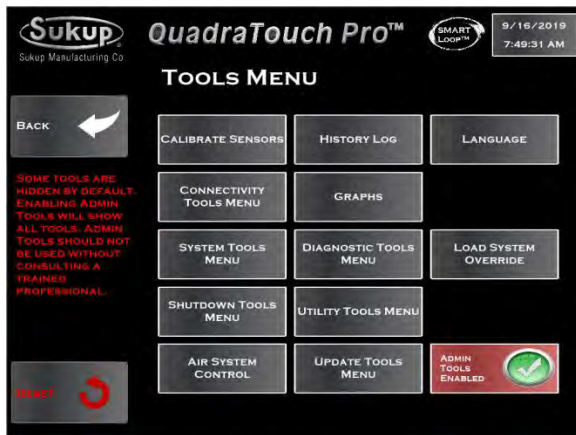

Tools

Cross-Flow/Mixed-Flow

Tools menu provides access to options to help improve drying, including moisture sensor calibration, air system controls, a history log, graphs, load system override, remote access and use of GSM modem.

Make sure Admin Tools are enabled to see tools that would otherwise be hidden.

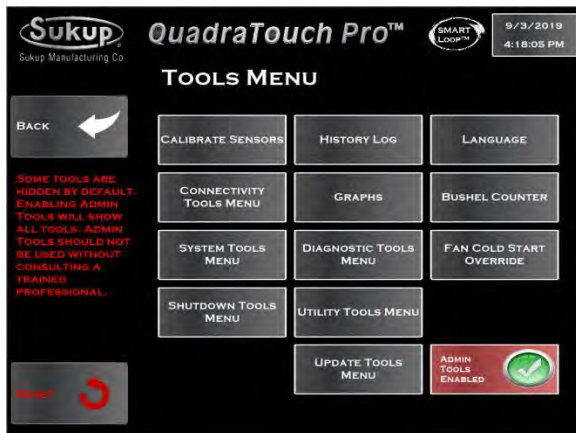

Tower

Tools menu provides access to options to help improve drying, including moisture sensor calibration, a history log, graphs, cold start override, remote access and use of GSM modem.

Make sure Admin Tools are enabled to see tools that would otherwise be hidden.

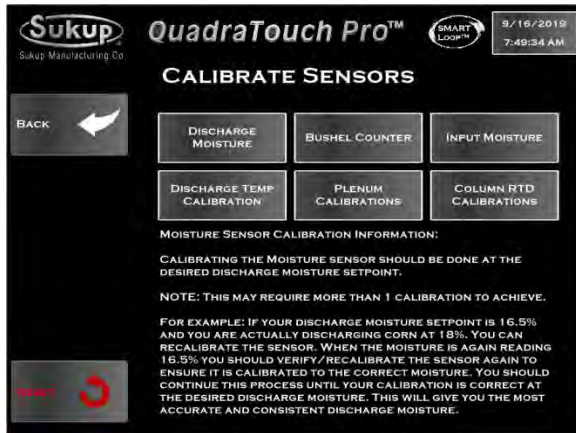

Calibrate Sensors

All Dryers

Tools → Calibrate Sensors

The dryer's moisture sensor(s), Plenum RTD's, and column RTD's, as well as bushel counter, can be calibrated here. Bushel counter must be calibrated in order to access the counting and bushel shutdown features shown in the Tools Menu.

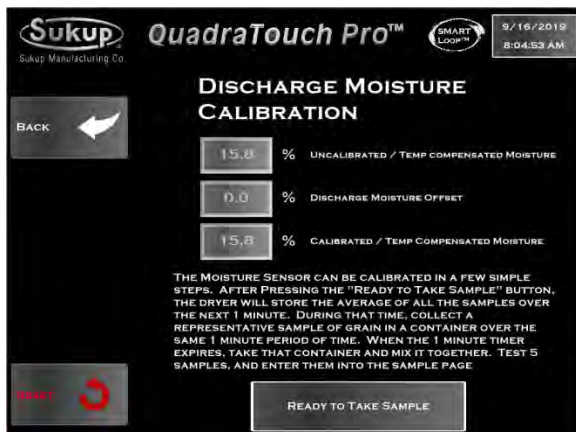

All Dryers

Tools → Calibrate Sensors → Discharge Moisture

Discharge moisture sensor may need to be calibrated during operation to ensure dryer is operating with accurate data. Press "Ready to Take Sample" button. Dryer will calculate the average of all samples it takes over the next minute. During that time, collect a sample. Do this five times.

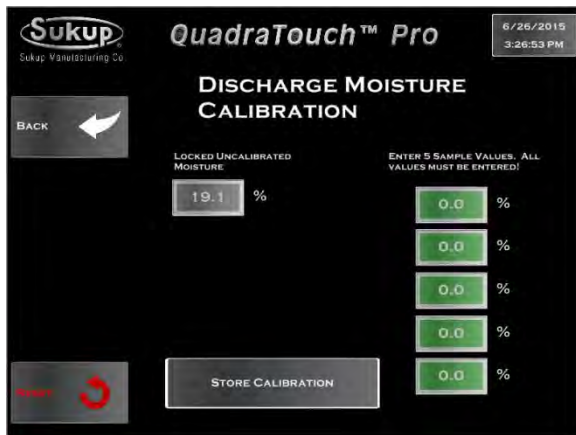

All Dryers

Tools → Calibrate Sensors → Discharge Moisture

Enter results of five samples on touch screen. The Locked, Uncalibrated Moisture value is what the dryer's sensor recorded over the past minute. Dryer will compare its data with your data and will store the calibration.



All Dryers

Tools → Calibrate Sensors → Bushel Counter

Bushel counter can be calibrated automatically or manually. Automatically is generally the most accurate. Dryer must be discharging grain into a cart or truck where quantity can be measured.

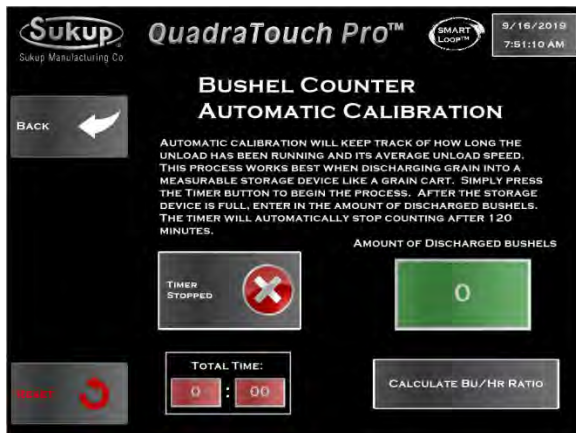

All Dryers

Tools → Calibrate Sensors → Bushel Counter → Automatic Calibration

Press button to start timer. When load is finished, press it again to stop timer. Enter the number of bushels discharged during that time. Dryer will calculate and store the bu/hr rate.



All Dryers

Tools → Calibrate Sensors → Bushel Counter → Manual Calibration

Use Manual Calibration only if Automatic is not possible. In Manual, user must enter meter roll speed and an approximate yield at that speed. Dryer will calculate and store the bu/hr rate.

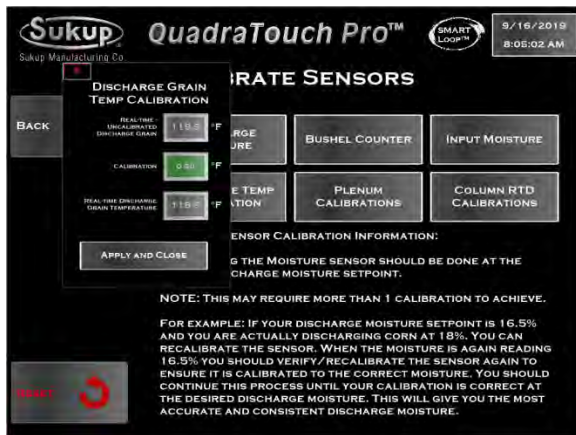

All Dryers

Tools → Calibrate Sensors → Discharge Temp Calibration

Press Calibration button to enter offset value. If dryer sensor is showing 120°F and user wants it to read 125°F, he/she would enter in 5. This sensor is generally very accurate, so exercise caution when adjusting this value.

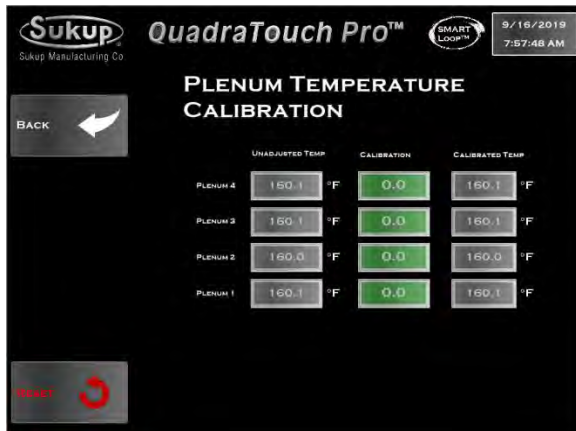

Cross-Flow/Mixed-Flow

Tools → Calibrate Sensors → Plenum Calibration

Press Plenum Calibration to enter calibration for each plenum temperature. These sensors are generally very accurate, so exercise caution when adjusting these values.

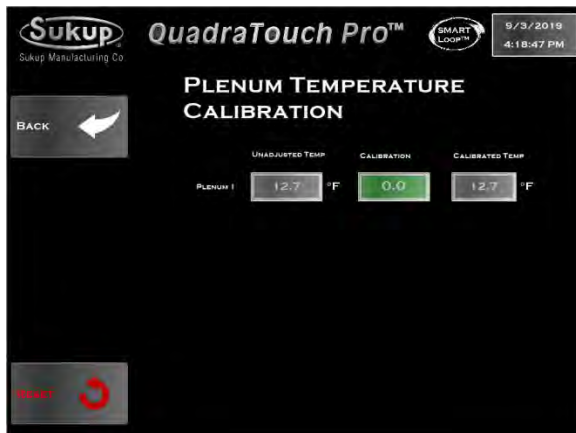

Tower

Tools → Calibrate Sensors → Plenum Temperature Calibration

Press Plenum Calibration to enter calibration for plenum temperature. This sensor is generally very accurate, so exercise caution when adjusting.

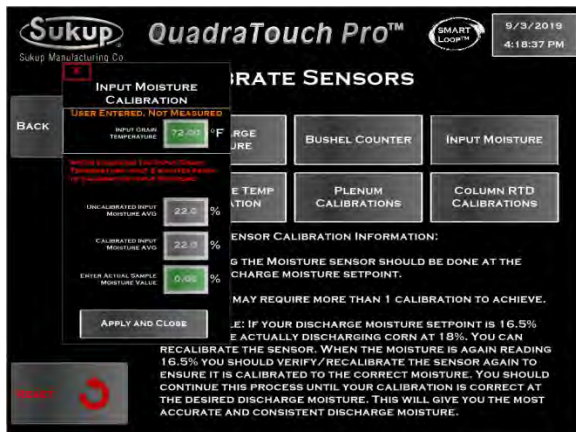

All Dryers

Tools → Calibrate Sensors → Input Moisture Sensor

Enter average of moisture content of multiple samples of grain. **NOTE:** Auger-fill cross-flow dryers do not have incoming moisture sensors unless specially ordered.

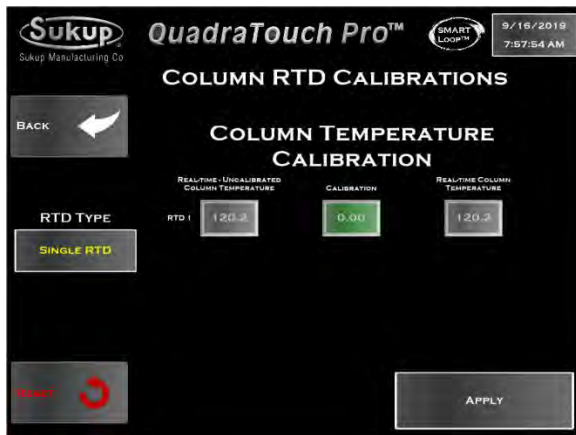

All Dryers

Tools → Calibrate Sensors → Column RTD Calibrations

Enter calibration for column RTD. This sensor is generally very accurate, so exercise caution when adjusting.



History Log

All Dryers

Tools → History Log

History log contains all alarms, settings changes, and fault history of dryer.

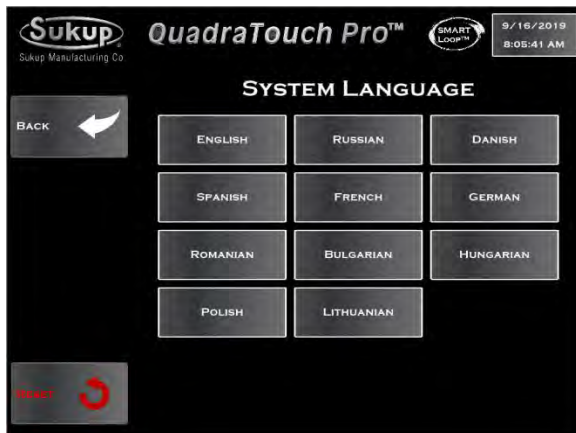

System Language

All Dryers

Tools → Language

Select language used by dryer operator.

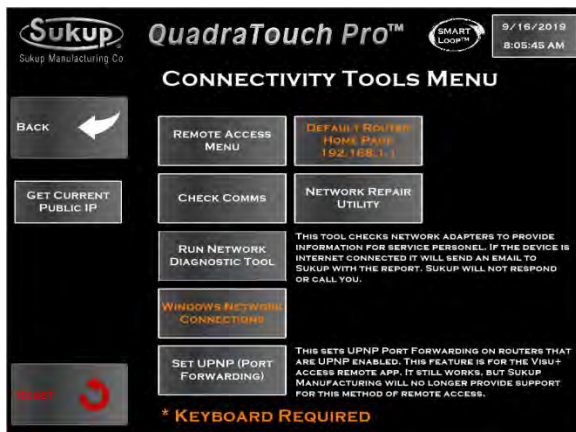

Connectivity Tools

All Dryers

Tools → Connectivity Tools Menu

This page provides access to various connectivity tools including setup of remote access via MySukup.com or GSM modem. Additionally, use of Network Diagnostic Tool and Network Repair Utility can be initiated here. **NOTE:** Keyboard is required for some functions.

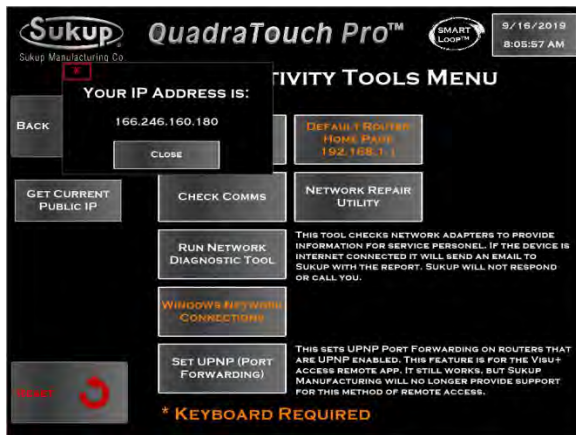

All Dryers

Tools → Connectivity Tools Menu → Get Current Public IP

Press Get Current Public IP button on left to obtain Internet Protocol Address.

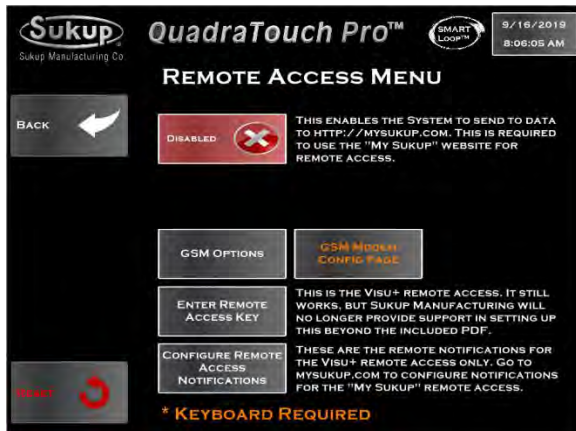

All Dryers

Tools → Connectivity Tools Menu → Remote Access Menu

If remote access is desired, press red button to obtain Personal Information Agreement.



All Dryers

Tools → Connectivity Tools Menu → Remote Access Menu

Read agreement and indicate preference on acceptance.

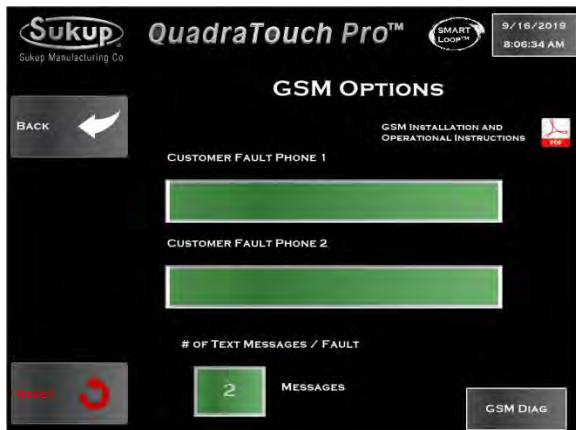

All Dryers

Tools → Connectivity Tools Menu → Remote Access Menu → GSM Options

Follow steps as prompted to set up MySukup.com or GSM connection. Image at left shows screen for entering phone numbers for GSM control. Press GSM Diag. box on lower right to get to diagnostics page.

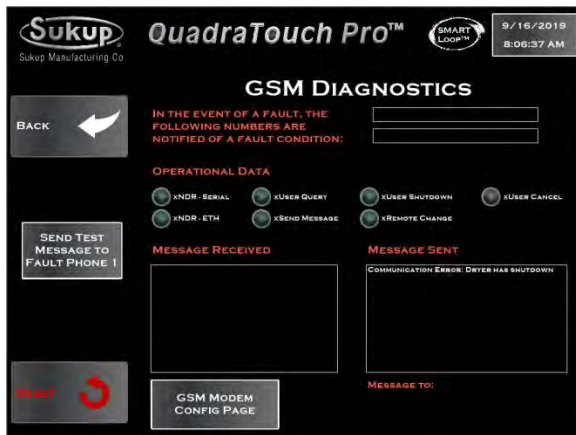

All Dryers

Tools → Connectivity Tools Menu → Remote Access Menu → GSM Options → GSM Diagnostics

GSM Diagnostics page helps with first-time setup to ensure modem is operating correctly.

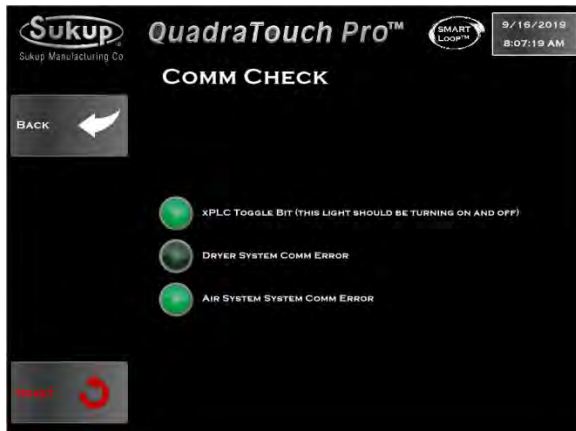

All Dryers

Tools → Connectivity Tools Menu → Check Comms

Pressing Check Comms button enables user to check connectivity with dryer's programmable logic controls and with air system if one is connected. The xPLC Toggle Bit button will turn on and off when PLC and touch panel are communicating.



All Dryers

Tools → Connectivity Tools Menu → Network Repair Utility

This utility attempts to diagnose and repair networking and communication errors. Activate by pressing button at lower right.

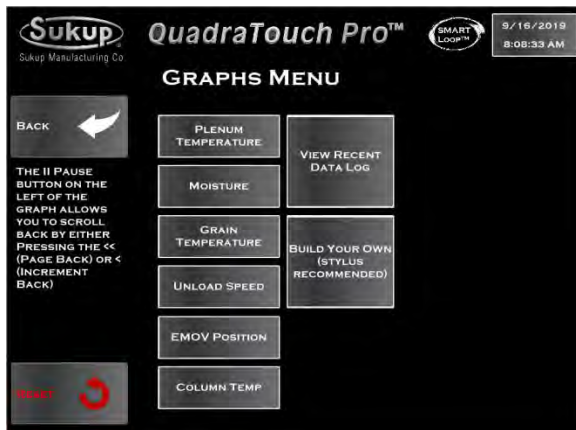

Graphs

All Dryers

Tools → Graphs

QuadraTouch Pro operating system allows dryer user to look at graphs both in real-time and for past. **NOTE:** Since some screens contain a lot of data, use of a stylus will be helpful.

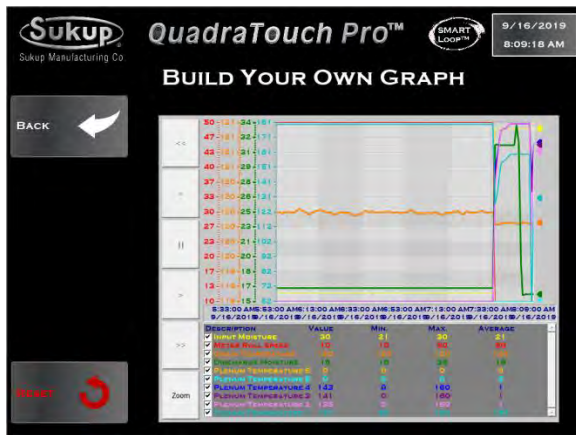

All Dryers

Tools → Graphs → Build Your Own Graph

Users can build their own graphs to compare multiple factors.

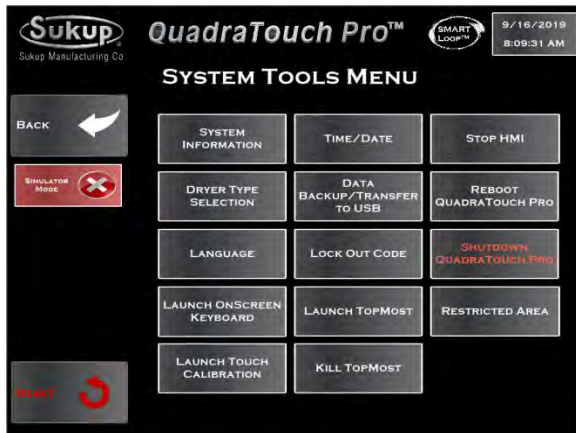

System Tools

All Dryers

Tools → System Tools Menu

This menu provides access to a wide range of functions and has many features that help maintain and update QuadraTouch Pro operating system.

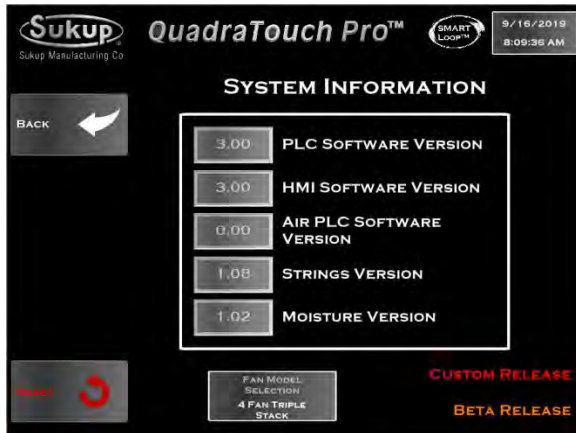

All Dryers

Tools → System Tools Menu → System Information

This page prompts user to input software versions for PLC, touch screen and air system if dryer is so equipped.



All Dryers

Tools → System Tools Menu → Time/Date

Enter current time and date.

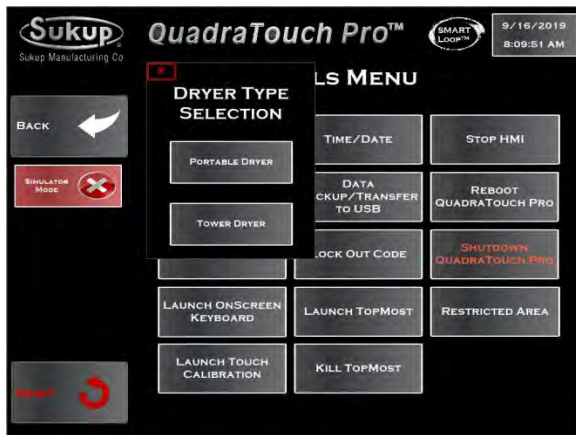

All Dryers

Tools → System Tools Menu → Dryer Type Selection

Enter type of dryer and number of fans if a cross-flow dryer. Enter model number if a tower dryer. For mixed-flow dryer, follow prompts to enter dryer characteristics.



All Dryers

Tools → System Tools Menu → Data Backup/Transfer to USB

Enter USB drive to be used for data backup.



All Dryers

Tools → System Tools Menu → Lock Out Code

Enter a four-digit lock-out code (Personal Identification Number). After proceeding, touch screen will be disabled unless code is entered.



All Dryers

Tools → System Tools Menu → Launch OnScreen Keyboard

Press Launch On-Screen Keyboard button to get pop-up keyboard.



All Dryers

Tools → System Tools Menu → Restricted Area

This page allows access to hidden screens for Sukup Personnel only.

All Dryers

Other System Tools include Touch Screen Calibration, Stop HMI (turn off touch panel), Reboot QuadraTouch Pro, Shutdown QuadraTouch Pro, Launch Topmost, Kill Topmost, Simulator Mode. See Page 20 to set language.

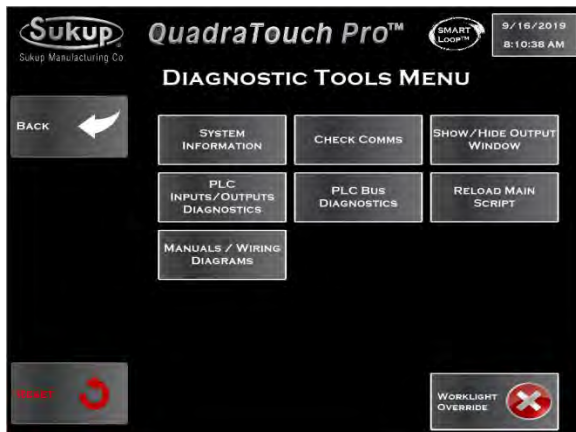

Diagnostic Tools

All Dryers

Tools → Diagnostic Tools Menu

Screen shows diagnostic tools that can be used. See Page 22 to Check Comms (communication between devices) and Page 23 for input of System Information if not done already.

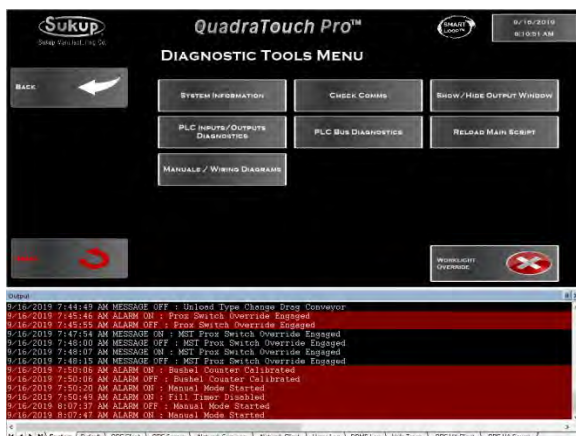

All Dryers

Tools → Diagnostic Tools Menu → Show/Hide Output Window

Pressing Show/Hide Output Button shows output window. It may look different than shown and can be dragged to other location on touch screen by pressing on Output bar.

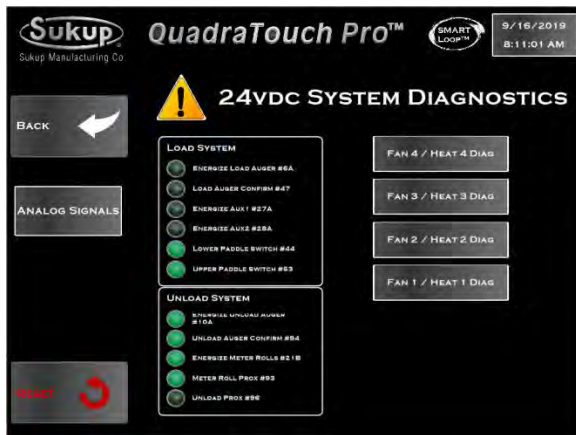

PLC Inputs/Outputs for All Dryers

Tools → Diagnostic Tools Menu → PLC Inputs/Outputs Diagnostics

This page provides an overview of load and unload systems, fans and heaters. A green light means the circuit has 24VDC on it. This menu can be accessed at almost any time by pressing Sukup logo (top left of screen) two times.

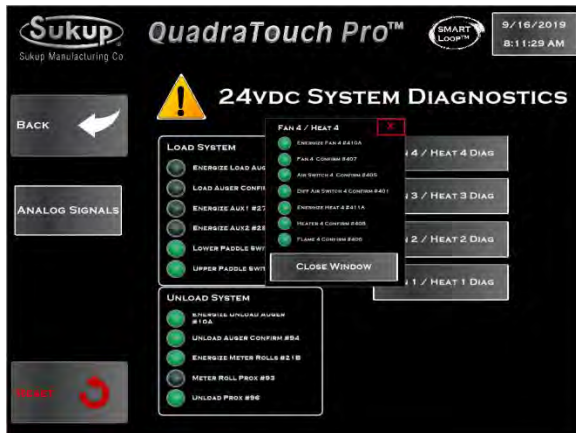

Individual fan inputs/outputs are shown in pop-up windows by pressing corresponding buttons.

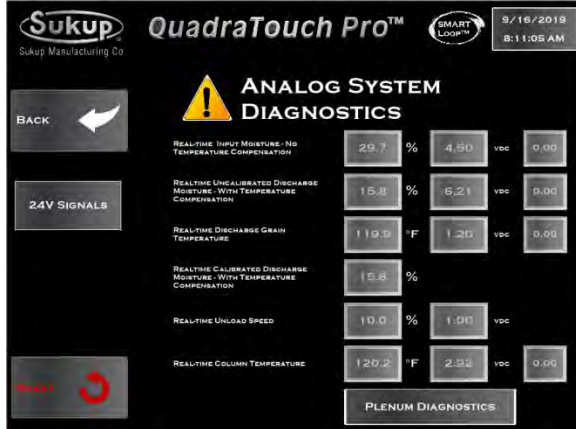

Tools → Diagnostic Tools Menu → Analog System Diagnostics

Press Analog Signals button on left of previous screen to get real-time readings on all analog input sensors and output reference signals. See image at left. This menu can be accessed at almost anytime by pressing SUKUP logo once at top left of touch screen.

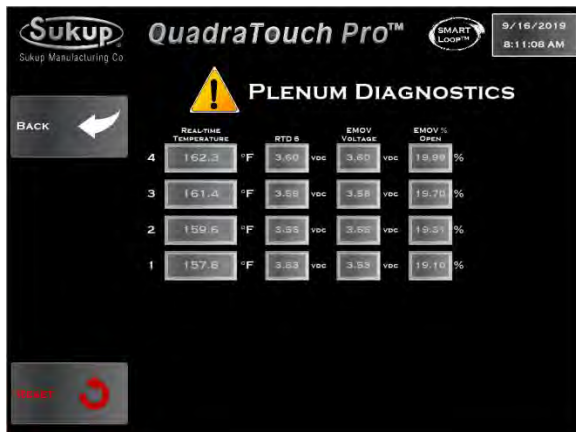

Tools → Diagnostic Tools Menu → Analog System Diagnostics → Plenum Diagnostics

Pressing Plenum Diagnostics button at bottom of previous screen will show each plenum feedback value, the reference signal and percentage opening on the EMOV. See image at left. This menu can be accessed at almost anytime by pressing SUKUP logo at top left of touch screen three times.

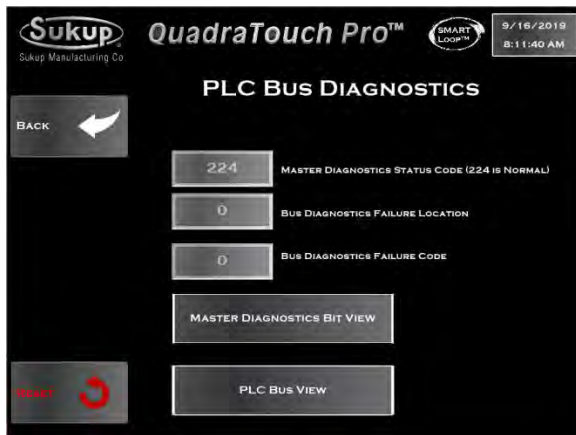

PLC Bus Diagnostics for All Dryers

Tools → Diagnostic Tools Menu → PLC Bus Diagnostics

This section provides critical information about PLC. This menu would only need to be accessed in the event of a PLC or I/O card failure.



Tools → Diagnostic Tools Menu → PLC Bus Diagnostics → Master Diagnostics Bit View

Press Master Diagnostic Bit View button to get pop-up window showing status of various diagnostics. Information contained here will most likely only be needed by a Sukup service technician.

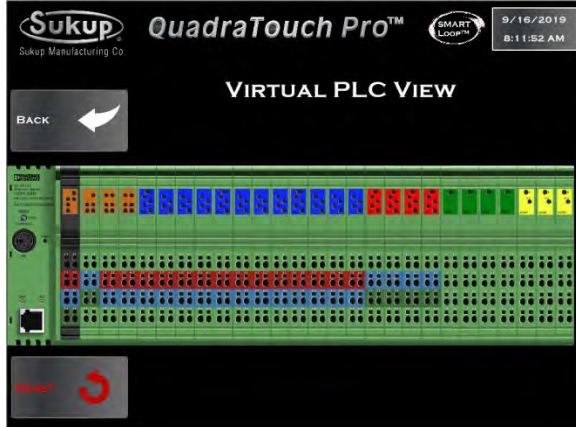

Tools → Diagnostic Tools Menu → PLC Bus Diagnostics → PLC Bus View

Press PLC Bus View for a view of dryer's PLC and identification of any problems with it. If a device is not functioning properly, it will be highlighted for easy identification.

All Dryers

Tools → Diagnostic Tools Menu → Reload Main Script

Press Reload Main Script button to restart the Main Script if it crashes and sends an error message. If that doesn't work, restart dryer.

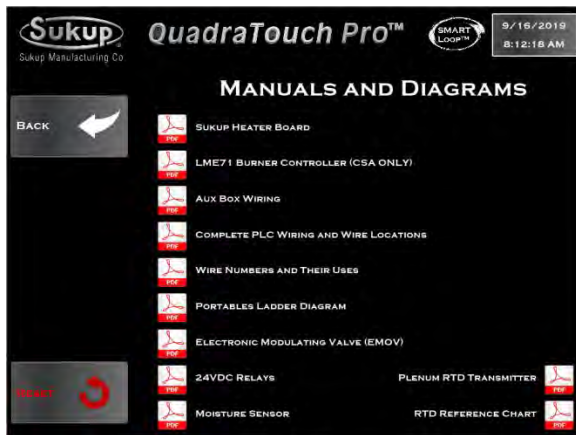

All Dryers

Tools → Diagnostic Tools Menu →
Manuals/Wiring Diagrams

Entire copies of system manuals and wiring diagrams can be found here, including information related to specific components and frequently asked questions.

All Dryers

Tools → Diagnostic Tools Menu → Worklight
Override

Press Worklight Override button at bottom right of Diagnostic Tools Menu page to energize worklight when a fault is preset. When in Override mode, worklight will not shut off if a fault occurs.

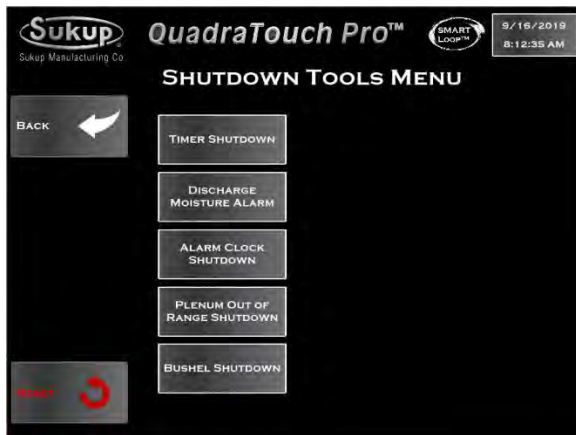

Shutdown Tools

All Dryers

Tools → Shutdown Tools Menu

This menu provides access for shutdown settings. User can specify amount of time for each function.



All Dryers

Tools → Shutdown Tools Menu → Timer Shutdown

Enter amount of time for dryer to run before shutting down.

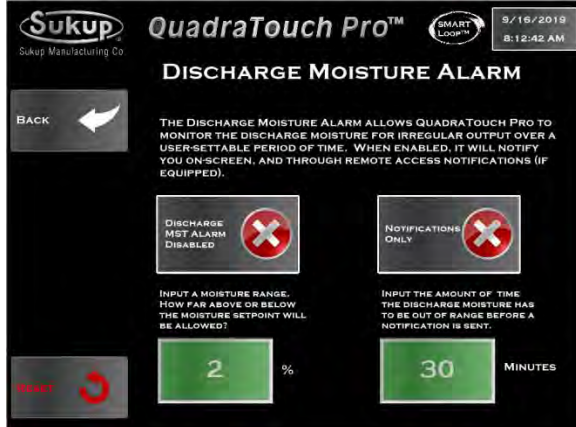

All Dryers

Tools → Shutdown Tools Menu → Discharge Moisture Alarm

Enter acceptable range of discharge grain moisture and amount of time it must be out of range before a shutdown occurs.



All Dryers

Tools → Shutdown Tools Menu → Alarm Clock Shutdown

Enter time at which you want dryer to shut down within next 24 hours

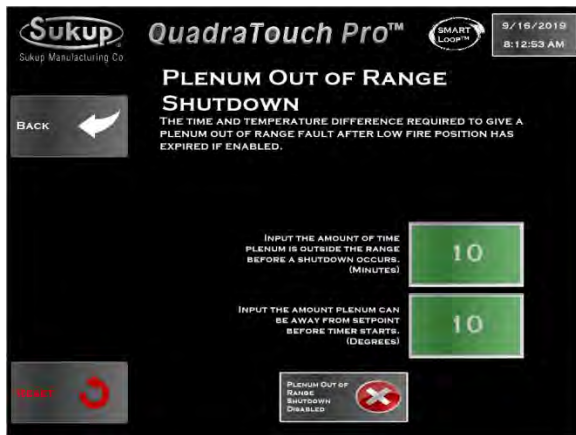

All Dryers

Tools → Shutdown Tools Menu → Plenum Out of Range Shutdown

Enter amount of time that plenum temperature can be out of range before a shutdown occurs. Also input acceptable temperature range.



All Dryers

Tools → Shutdown Tools Menu → Bushel Shutdown

Enter number of bushels to be dried before dryer shuts down. NOTE: This feature is only available after calibrating bushel counter



Utility Tools

All Dryers

Tools → Utility Tools Menu

Press IP Assign button to use IP Assignment Wizard to assign an IP address to a new out-of-box PLC.

Press PLC Start/Stop Tool to force a PLC program to start/stop.



Air System Control

Cross-Flow/Mixed-Flow

Tools → Air System Control

Enabling Air System Controls will allow dryer to start air system when air system is in Automatic mode. This will prevent dryer from unloading unless air system is ready for grain. See Cyclone Installation & Operation Manual, L1396.

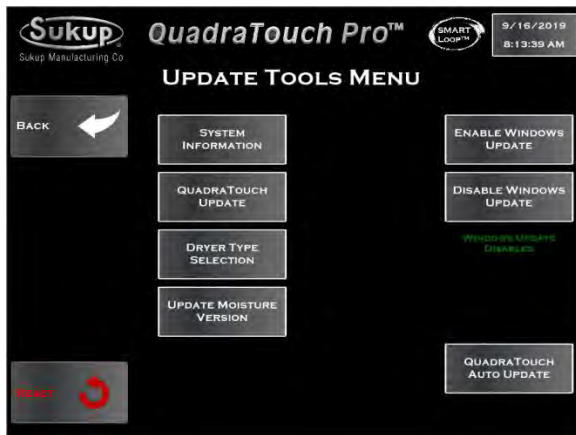

Update Tools

All Dryers

Tools → Update Tools Menu

This page provides access to enter system information (See Page 23), update QuadraTouch Pro software, enter type of dryer (See Page 24) and update version of moisture sensor(s).

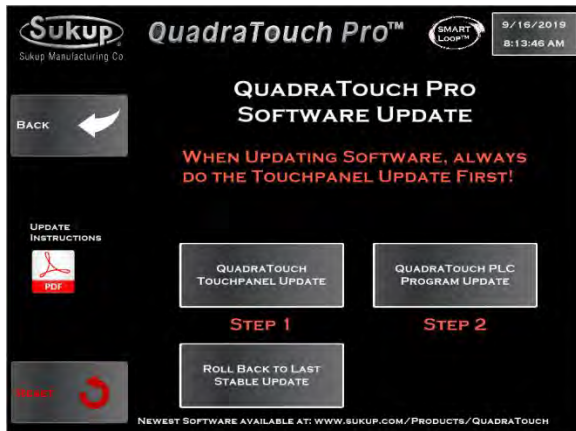

All Dryers

Tools → Update Tools Menu → QuadraTouch Update

Follow prompts on this page to update QuadraTouch Pro software.

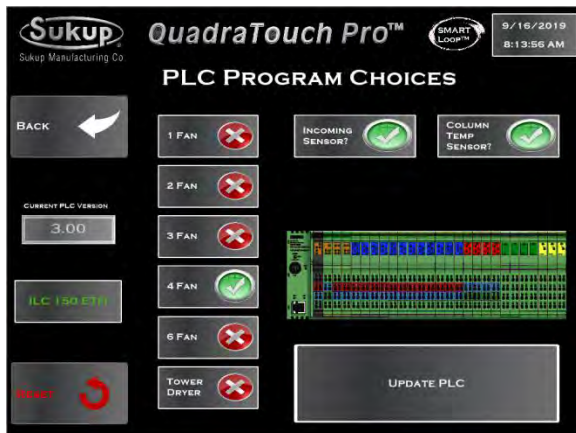

All Dryers

Tools → Update Tools Menu → QuadraTouch Update → PLC Program Choices

Follow prompts on this page to update PLC.



All Dryers

Tools → Update Tools Menu → QuadraTouch Update → Update Moisture Version

Follow prompts on this page to update moisture sensor version.

All Dryers

Tools → Update Tools Menu

Press Enable Windows Update or Disable Windows Update on right side of Update Tools Menu as desired.

All Dryers

Tools → Update Tools Menu → QuadraTouch Auto Update

Press QuadraTouch Auto Update at bottom right of screen and follow prompts to update software automatically.

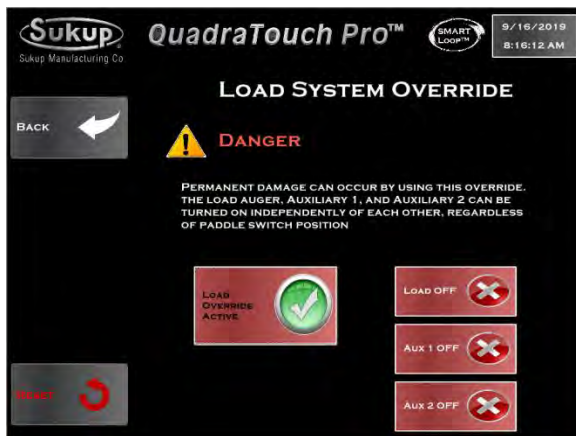

Load System Override

Cross-Flow/Mixed-Flow

Tools → Load System Override

Sometimes it is necessary to run load auger or auxiliary devices independently of one another irrespective of the fill switch status. This mode allows that. However, permanent damage can occur if it's not used properly.



Tower Cold Start Fan Override

Tower

Tools → Tower Cold Start Fan Override

Fans on a tower dryer typically start in staged order. Use buttons on this page to start fans independently. Use this option only to warm up fans in very cold weather. Admin Tools must be enabled.



Cross-Flow/Mixed-Flow Operation

Pressing Start on main screen will bring up Start Menu. Dryer can be used in many different drying modes, the most common of which is Continuous Flow. This section will describe each mode and how it's accessed.

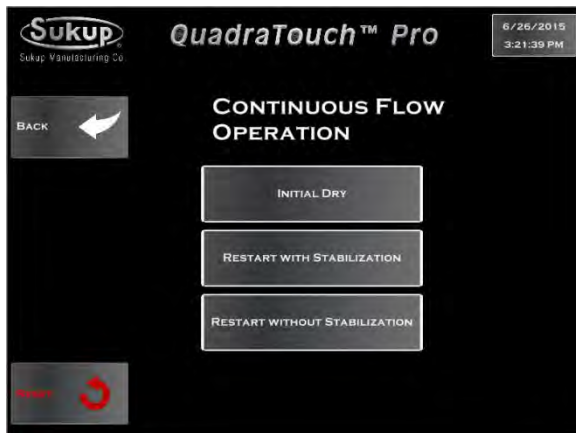

Continuous Flow (Automatic)

Start → Continuous Flow

Continuous Flow is divided into three processes when grain is loaded into dryer for the first time. Initial Dry essentially warms up the grain for a set period of time depending on user input. Fans and heaters will turn on and a timer will appear on the screen. This is essential for creating a steady flow of grain through the next step, Stabilization.

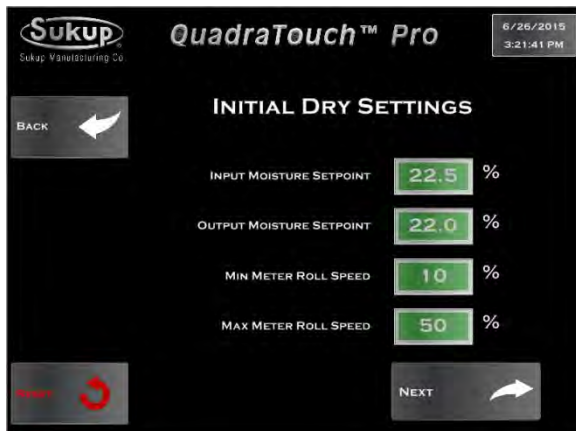

Start → Continuous Flow → Initial Dry

To begin Initial Dry, the dryer needs some information to get started. To give it an idea of how long to heat the first batch of grain, enter in the values of the incoming and desired output moisture. Press Next to continue on to the loading phase.

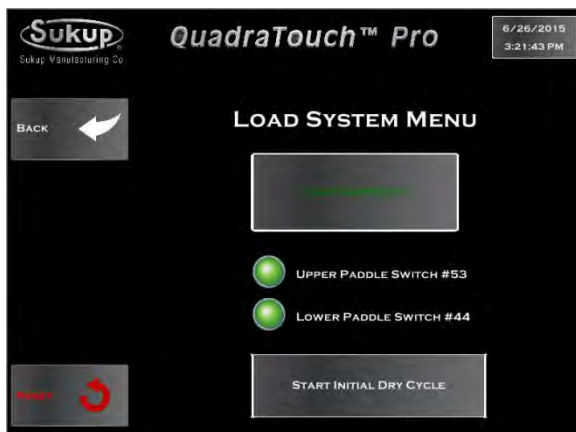

Start → Continuous Flow → Initial Dry → Next

Now that dryer has been programmed with a few basic settings, it is ready to be loaded with grain and to start Initial Dry. After loading, a button will appear to start Initial Dry cycle.



Start → Continuous Flow → Restart with Stabilization → Fan/Heat Control

After Initial Dry is finished, Stabilization is the next phase of Continuous Flow Mode. Stabilization is designed to go through one full cycle of grain, discharging at a calculated roll speed. **NOTE:** Warmup is used for cold climates to thaw frozen grain systems. The first step of stabilization is to select which fans and heaters should be used. **NOTE:** A heater will not be enabled unless its corresponding fan is used.

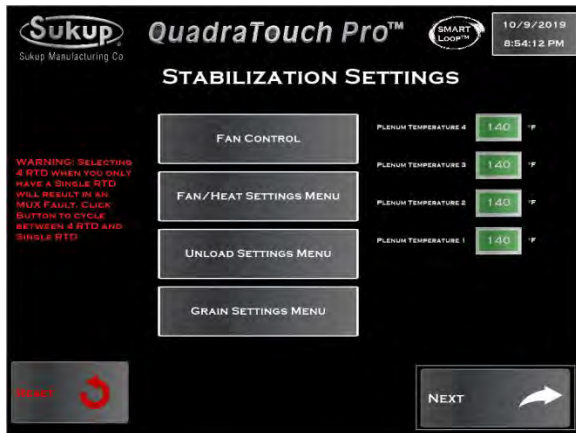

Start → Continuous Flow → Restart with Stabilization → Fan/Heat Control → Stabilization Settings

All previous settings will be stored from last time dryer was run, so make any changes necessary on this page before calculating the stabilization speed.

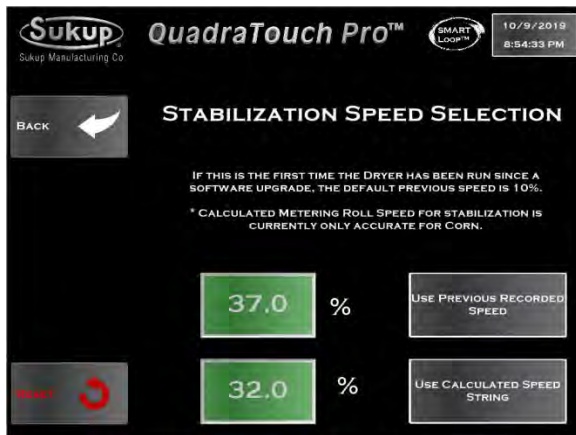

Start → Continuous Flow → Restart with Stabilization → Fan/Heat Control → Stabilization Settings → Next

On Stabilization Settings page, press Next button at lower right. Stabilization speed in green box is the last recorded speed when the dryer was running in Continuous Flow mode. If dryer was running well the last time it was used, using this value for Stabilization is recommended.

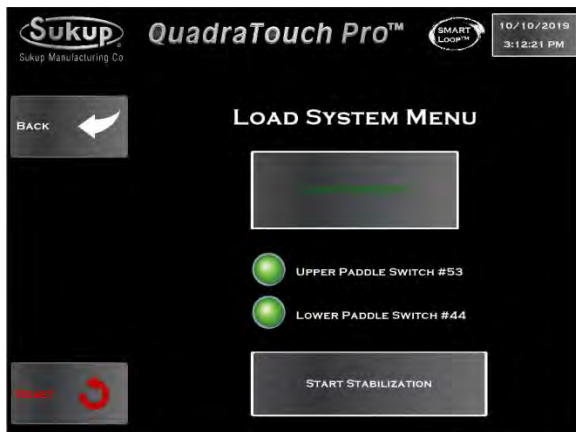

Start → Continuous Flow → Restart with Stabilization → Fan/Heat Control → Stabilization Settings → Next → Use Calculated Speed String

If dryer is coming out of Initial Dry, the screen will automatically switch to Stabilization mode. If Initial Dry has not been performed, the Load System Menu will appear. After dryer has been loaded with grain, a button will appear to start Stabilization.

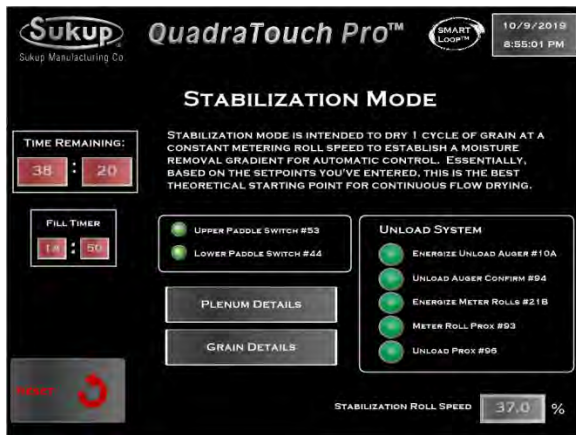

Start → Continuous Flow → Restart with Stabilization → Fan/Heat Control → Stabilization Settings → Next → Use Calculated Speed String → Start Stabilization

Plenum temperature and discharge moisture setpoint can be confirmed or changed.



Dry Fire

Start → Dry Fire

Dry Fire mode allows the dryer to turn its fan(s) and heater(s) on when the dryer is empty. This mode should be run every year before operation to test for functionality. Be sure to inspect each heater and pipe train for component integrity and functionality.



Start → Dry Fire → Dry Fire Mode

Dry Fire mode lasts for 10 minutes. Status of the signals will be displayed. When dryer is empty, the air switch will most likely not be closed.



Final Dry

Start → Final Dry

Final Dry mode is used to finish off the last “batch” when there is no more grain to dry in continuous flow. The dryer will batch dry the last grain in the dryer, then turn its fan(s) and heater(s) off and unload the dryer for a set period of time.



Start → Final Dry → Start Dry Fire

Final Dry mode will automatically exit when the timers have expired.

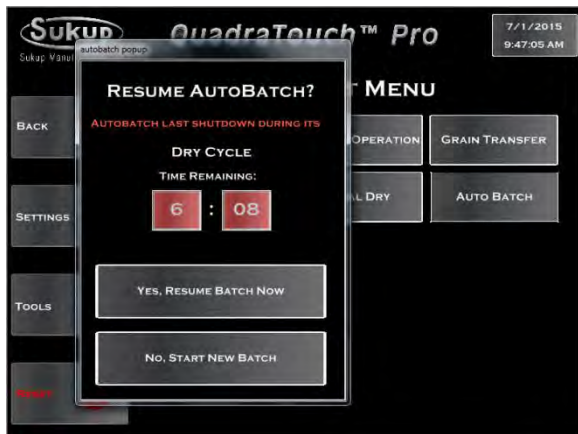

Auto Batch

Start → Auto Batch

Due to very high moisture content, Auto Batch mode may be required. After selecting Auto Batch, the system will prompt user about restarting from the last batch. If no previous batch has been recorded, it will start from the new batch settings.

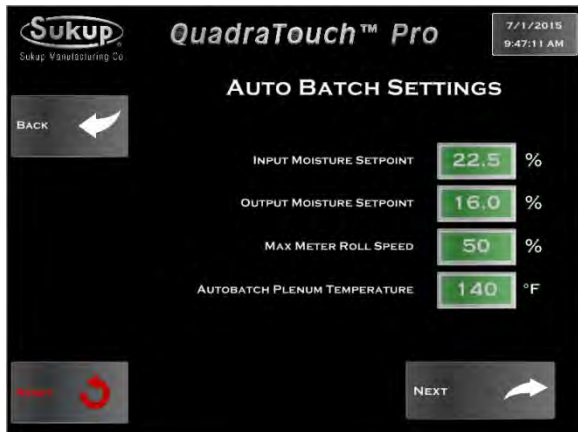

Start → Auto Batch → Start New Batch

Enter settings for Auto Batch.

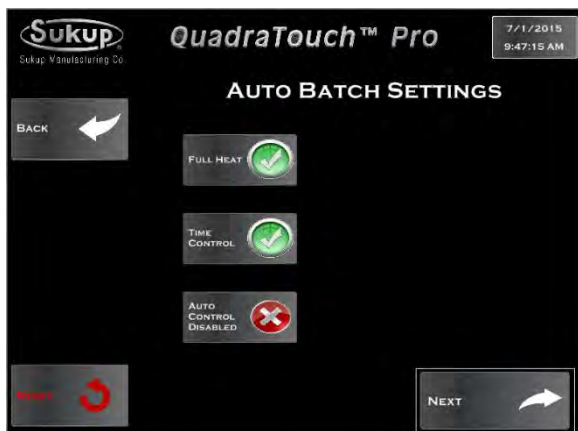

Start → Auto Batch → Start New Batch → Auto Batch Settings

Choose heat or heat/cool operation and control method.

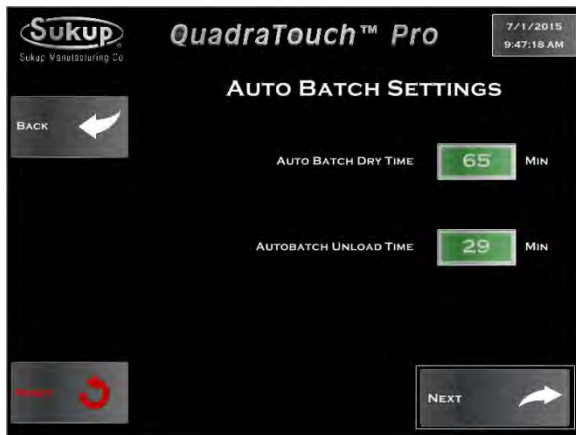

Start → Auto Batch → Start New Batch → Auto Batch Settings

Based on entered settings, dryer will calculate a base point to start from.

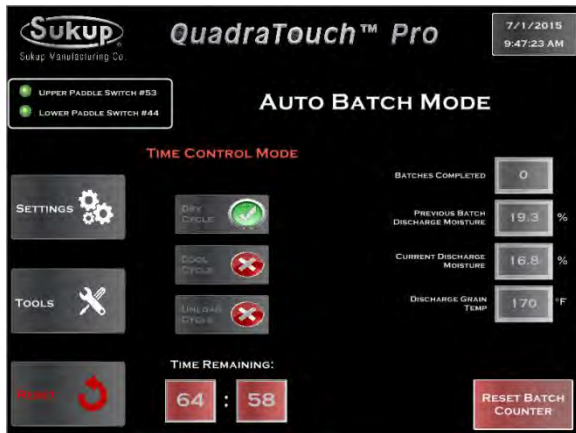

Start → Auto Batch

Auto Batch will start with the Dry Cycle. After the timer expires, the Cool Cycle will be used (if heat/cool operation was selected), then the dryer will start unloading the batch.

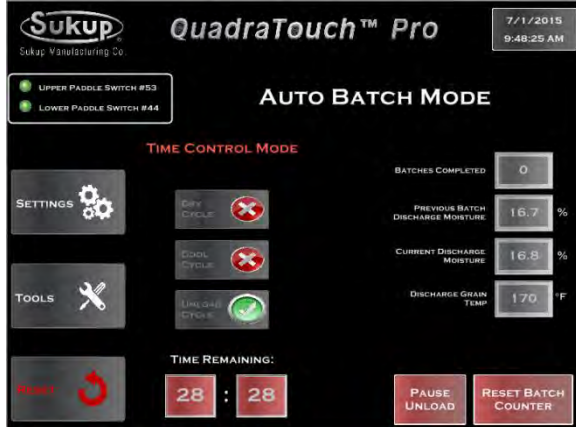

Start → Auto Batch

The Unload Cycle can be paused during operation, but needs to be resumed before the next cycle starts. Each of the mode times can be changed using the settings menu.

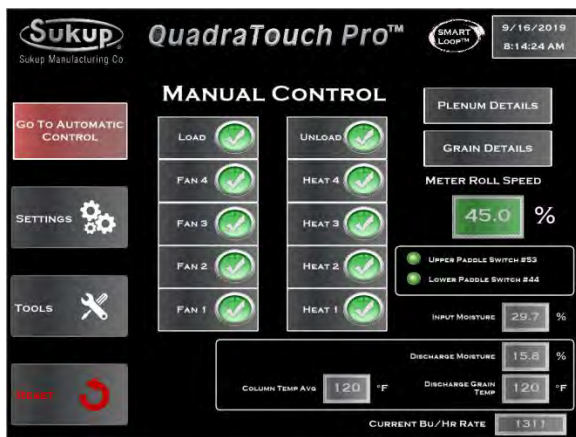

Manual Operation of Cross-Flow/Mixed-Flow Dryers

Start → Manual Operation

Plenum temperature and discharge moisture setpoints can be set.

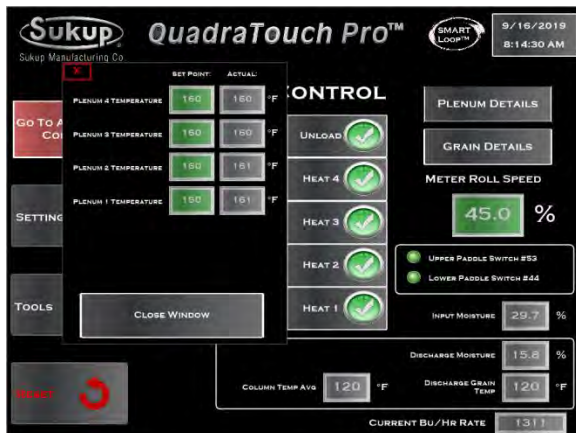

Start → Manual Operation

Press Plenum Details to get a pop-up window to enter plenum temperature setpoint.

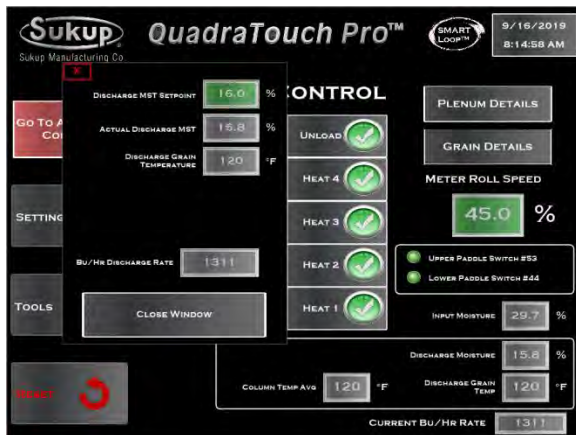

Start → Manual Operation

Press Grain Details to get a pop-up window to enter discharge moisture setpoint.

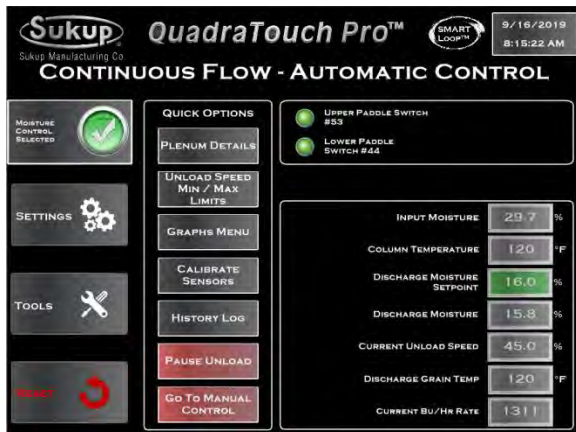

Start → Manual Operation

Press Go to Automatic Control button to get to Continuous Flow Automatic Control page.

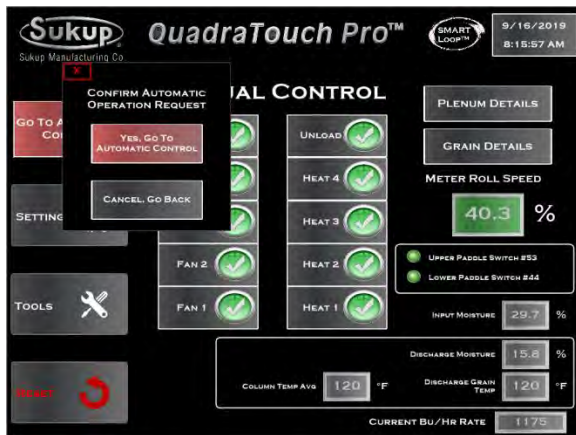

Start → Manual Operation → Go to Automatic Control → Confirm Automatic Operation Request

Press Yes if automatic control is desired, then press Plenum Details.

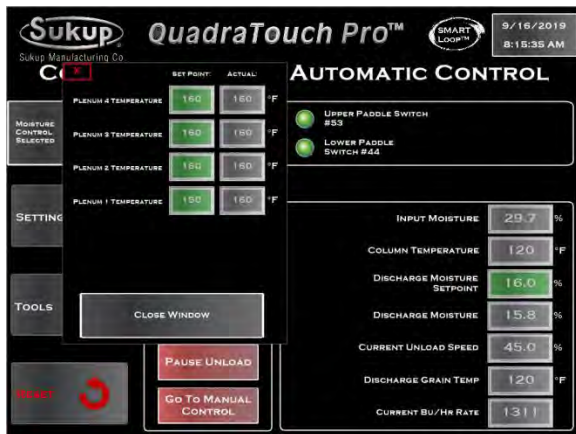

Start → Manual Operation → Go to Automatic Control → Plenum Details

Press Plenum Details button to reset plenum setpoint(s) if desired.

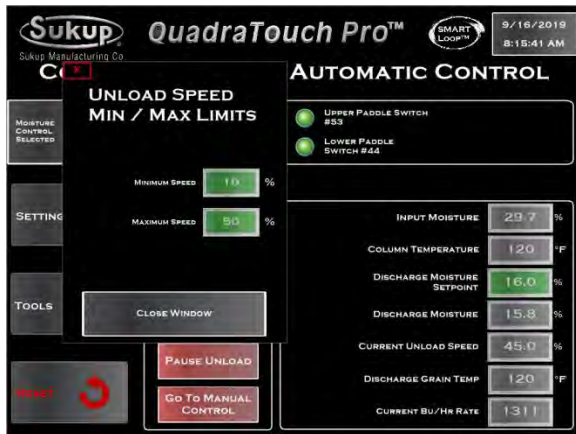

Start → Manual Operation → Go to Automatic Control → Unload Speed Min/Max Limits

Press Unload Speed Min/Max Limits to reset unload speeds if desired.

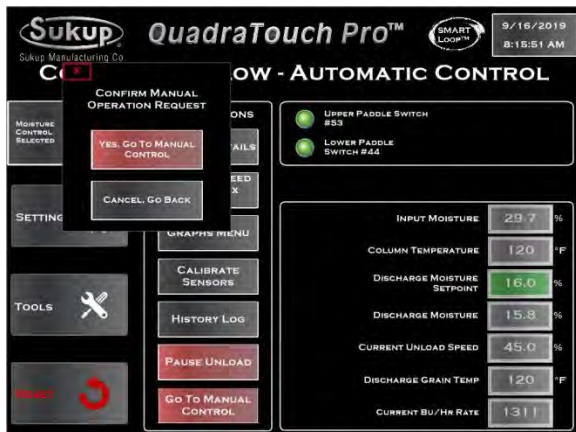

Press Go to Manual Control button at bottom of screen and confirm in pop-up window.



Resetting to QuadraTouch Pro Home Page

All Dryers

Pressing red Reset button will bring user back to home page. This image will appear in screen while touch panel is resetting.

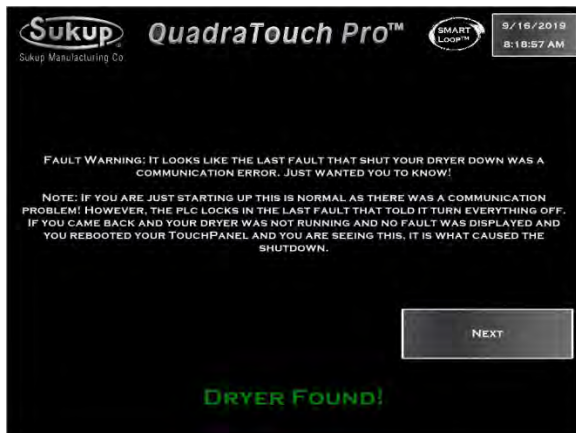

All Dryers

When first powering up dryer it will attempt initial connection. If initial connection fails it will say dryer not found. If a connection is made it will say dryer found.

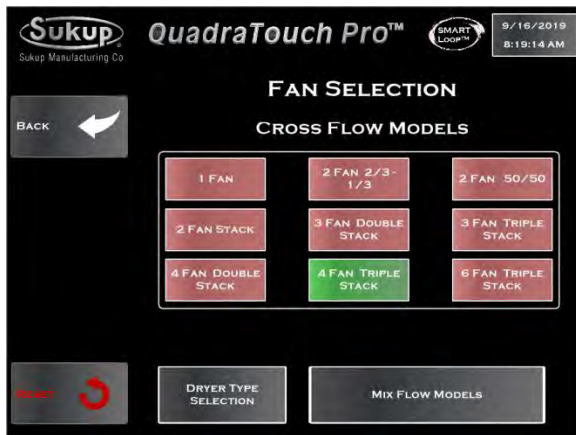

Fan/Model Selection

All Dryers

On home page, press Fan Model Selection in lower right corner. Follow prompts to enter type of dryer and number of fans. Image at left shows fan-selection page for cross-flow dryer. Press "Back" after making selection.

Press Dryer Type Selection and Tower Dryer to select tower dryer model (See below), or Mix Flow Models to set type of mixed-flow dryer (See next page).

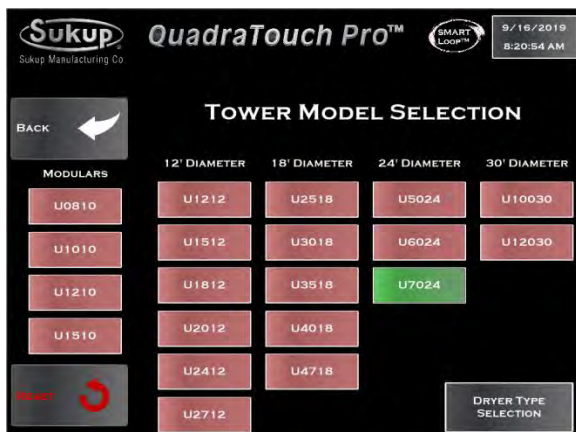

Image at left shows model selection page for tower dryer. Press "Back" after making selection.

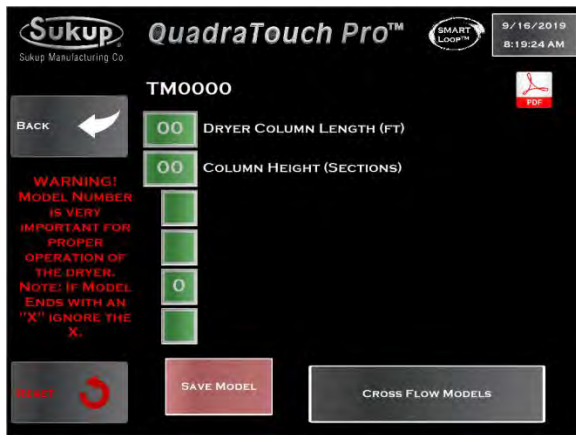

Image at left shows screen for entering dryer length and column height (tiers) for mixed-flow dryers.



Image at left shows pop-up window for entering number of (tiers) for mixed-flow dryer.



Image at left shows pop-up window for entering start type (Soft start, line start, VFD start) and expandability of dryer.

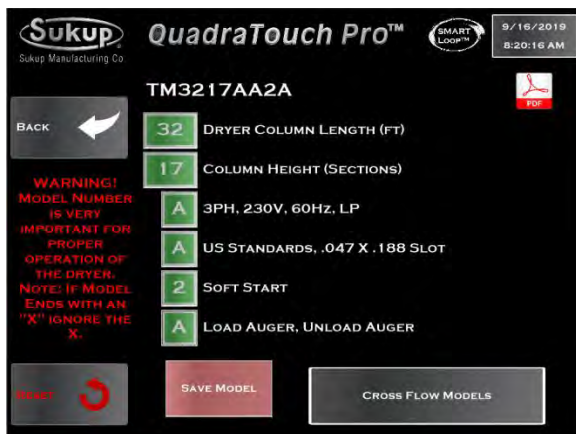

Image at left shows dryer identification screen after entry of all parameters. Press "Save Model" after confirming selections.



Tower Dryer Operation

When operating Tower Dryer, the program flow is similar to that found on previous pages for cross-flow/mixed-flow dryers, with a few exceptions. They are described here.

The first key difference is in the Start menu. It will prompt you to answer if the burner tarp has been removed.

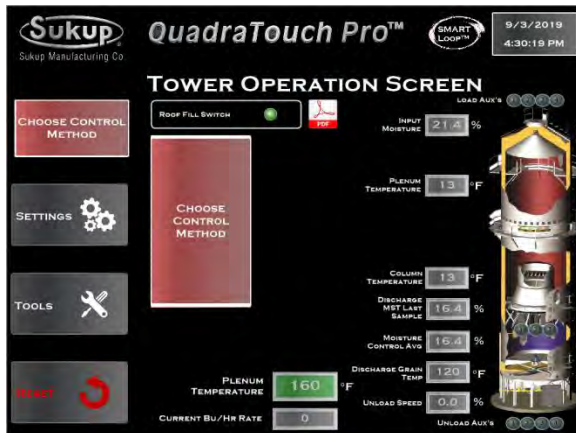

Choosing Control Method

In Tower Operation, choose the control method (automatic or manual). The control method can be changed by pressing either of the two red rectangles.

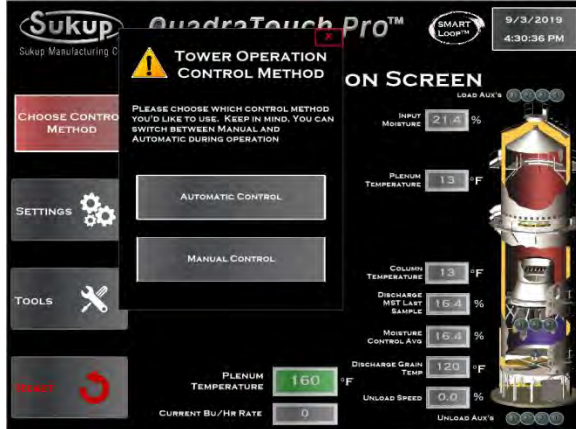

Choose how you'd like to operate the Tower Dryer, Automatic or Manual.

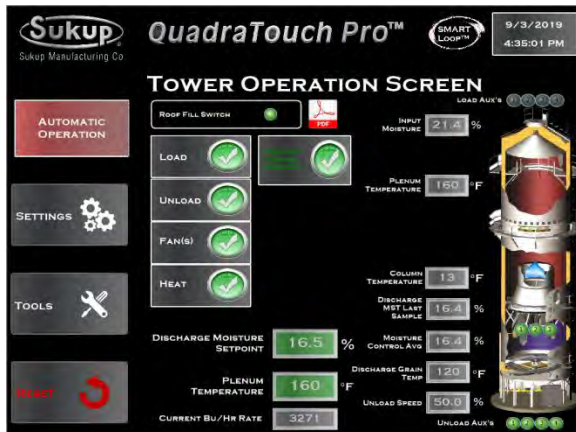

Automatic Operation

Choosing Automatic Operation, the larger of the two red rectangles disappears, leaving the controls for the load and unload systems, fan(s) and heater(s).

Notice there is a blinking button indicating you are discharging based on moisture or grain column temperature.

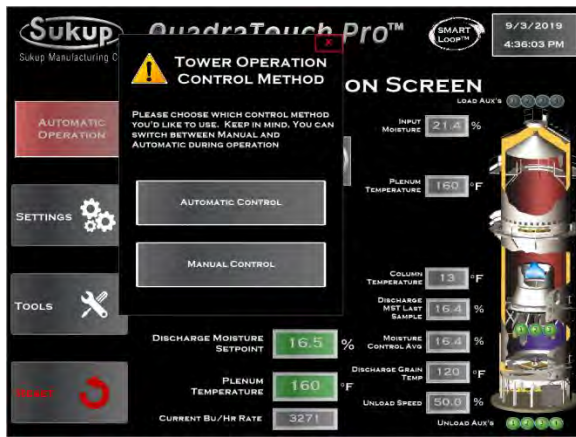

Changing from Moisture to Temperature Control

toggling the blinking button will change from moisture to temperature control. You'll notice the temperature setpoint will appear on the bottom in place of the moisture setpoint.

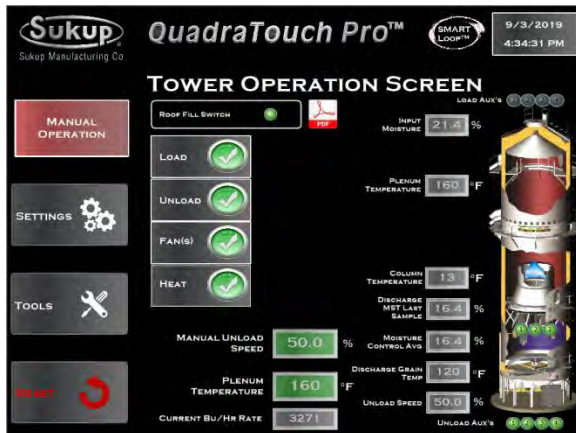

Manual Operation

Choosing the red rectangle, you can change the operation method to Manual as shown here. Notice the moisture and temperature setpoints are removed, and they are replaced with a manual unload speed setting.

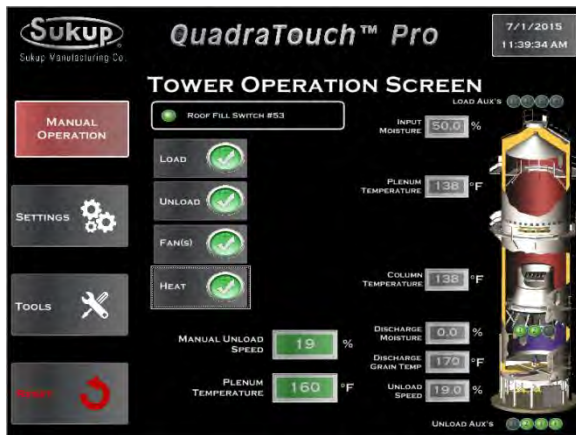

Turning the load, unload, fan(s), and heat on, you can see the devices turning on in order. The fans will start up in sequence along with the load and unload systems. An animated blue flame will show up when the burner control unit senses flame.

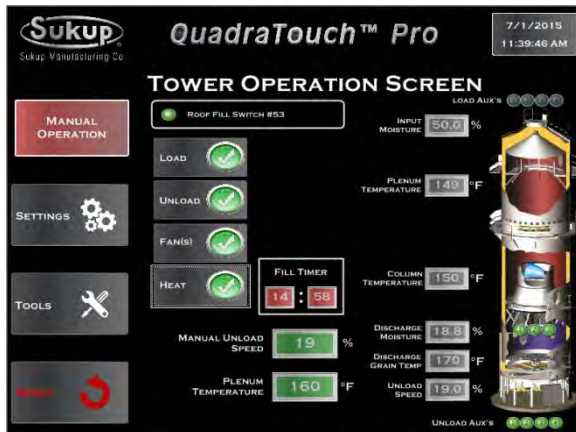

As soon as the unload table has started, any applicable countdown timers will be displayed. Notice the Fill Timer displayed in the bottom center of the screen.



Sukup Manufacturing Co.

1555 255th Street, Box 677

Sheffield, Iowa, USA 50475-0677

Phone: 641-892-4222

Fax: 641-892-4629

Website: www.sukup.com

Email: info@sukup.com

Electrical Drawings

**Wire numbers and uses
Electrical drawings**

<u>DATE</u>	<u>REVISION</u>	<u>PAGE</u>
12/28/2022	– Edited listings & table formatting	2-5

Wire Numbers & Uses – QuadraTouch Pro Tower Dryer

Common System Wires		
Wire #	Description	Use
LINE	120VAC supply from transformer to CB7	Line power from transformer
0	120VAC from bottom of CB2 to E-Stop	Conductor between CB2 and E-Stop
1	120VAC supply after E-Stop	Emergency switched control supply
2	Neutral wire	Provides return for 110V circuits
4	Main shunt trip	Trips main disconnect by breaking 110V circuit
5	Aux load #1 (Dry contact)	Connects to 5C when K12 relay is energized
5A	28VDC aux load #1 PLC load relay coil	28VDC energizes relay K12
5C	Aux load #1 (Dry contact)	Connects to 5 when K12 relay is energized
6	Aux load #2 (Dry contact)	Connects to 6C when K13 relay is energized
6A	28VDC aux load #2 PLC load relay coil	28VDC energizes relay K13
6C	Aux load #2 (Dry contact)	Connects to 6 when K13 relay is energized
7	Aux load #3 (Dry contact)	Connects to 7C when K14 relay is energized
7A	28VDC aux load #3 PLC load relay coil	28VDC energizes relay K14
7C	Aux load #3 (Dry contact)	Connects to 7 when K14 relay is energized
8	Aux load #4 (Dry contact)	Connects to 8C when K15 relay is energized
8A	28VDC aux load #4 PLC load relay coil	28VDC energizes relay K15
8C	Aux load #4 (Dry contact)	Connects to 8 when K15 relay is energized
9	120V heater strips on gas valves	When main switch is on, 110V is supplied
10A	28VDC unload power ON from PLC	28VDC energizes unload relay K21
10D	28VDC to VFD LI1	28VDC energizes LI1 on VFD
11A	28VDC heater enable from PLC	28VDC energizes relays K5A & K5B
11B	28VDC heater interlock from PLC	28VDC energizes relays K6A & K6B
12	120V alarm horn	120V supplied when relay K7 is energized
12A	28VDC alarm horn from PLC	28VDC energizes relay K7
13	120V red light	120V supplied when relay K8 is energized
13A	28VDC red light from PLC	28VDC energizes relay K8
14	120V ignition transformer	Supplies voltage to igniter
15	120V pilot solenoid valve	Supplies voltage to solenoid valves through LME 69
16	120V to main gas valves	Supplies voltage to main gas valves through LME 69
17	Reference voltage from PLC to VFD	0 to 10 volt reference for AC drive (1V = 10% meter roll; 10V = 100% meter roll)
18	24V supply	Powered from PLC DC supply, provides voltage for sensors
19	120V switch leg for work light	Provides switched 120V for work light (120V present, work light ON)
19A	24VDC K5 PLC work light relay coil	28VDC present energizes PLC work light relay K5
22	120V low gas pressure switch	Supplies voltage to Dungs low-pressure switch
23	120V high gas pressure switch	Supplies voltage to Dungs high-pressure switch
24	120V to heater interlock	120V to heater interlock relay K6A
25	120V to 1st gas valve for proof of closure	120V to 1st gas valve and heater on CR2A relay
26	120V to 2nd gas valve for proof of closure	120V to 2nd gas valve (POC)
27	120V to heater-enable relay	120V from heater on CR2A to heater enable K5A relays
28	120V low-fire limit switch	120V to limit switch and heater on CR2B relay
29	120V low-fire limit switch	120V to LME 69 burner control unit

Wire Numbers & Uses – QuadraTouch Pro Tower Dryer

Common System Wires		
Wire #	Description	Use
30	Aux unload #4 (Dry contact)	Connects to 30C when K16 relay is energized
30A	28VDC aux unload #4 PLC load relay coil	28VDC energizes relay K16
30C	Aux unload #4 (Dry contact)	Connects to 30 when K16 relay is energized
31	Aux unload #3 (Dry contact)	Connects to 31C when K17 relay is energized
31A	28VDC aux unload #3 PLC load relay coil	28VDC energizes relay K17
31C	Aux unload #3 (Dry contact)	Connects to 31 when K17 relay is energized
32	Aux unload #2 (Dry contact)	Connects to 32C when K18 relay is energized
32A	28VDC aux unload #2 PLC load relay coil	28VDC energizes relay K18
32C	Aux unload #2 (Dry contact)	Connects to 32 when K18 relay is energized
33	Aux unload #1 (Dry contact)	Connects to 33C when K18 relay is energized
33A	28VDC aux unload #1 PLC load relay coil	28VDC energizes relay K19
33C	Aux unload #1 (Dry contact)	Connects to 33 when K18 relay is energized
34	28VDC load system start	28VDC signal from PLC Load On
35	28VDC unload system start	28VDC signal from PLC Unload On
36	Rear door signal wire	28VDC present = Door closed, provides voltage at PLC for door status (Doors are in series)
37	Vapor over-temp (LP dryers only)	28VDC present = status OK, provides voltage at PLC for over-temp switch status
38	Burner failure	28VDC supplied to PLC for heater fault relay CR3 closes
39	Plenum over-temp	28VDC = status OK, provides voltage at PLC for plenum high temperature
43	Heater interlock LME 69	120V = status OK, provides voltage to LME 69 through relay K6B
45	Flame-on signal	28VDC supplied to PLC for heater on signal when relay CR2C closes
46	Flame sensing	Min. 5 micro amp signal required to LME 69 burner control unit
47	PLC load on input	28VDC present = Load ON, provides PLC with status of load operation (on or off)
48	Heat-on signal	28VDC present = Heat ON, provides PLC with status of load operation (on or off)
49	Motor overload - Fan #3	28VDC present = status OK, provides voltage back to PLC for Fan #3 overload status
49A	Motor overload - unload motor	28VDC present = status OK, provides voltage back to PLC for overload status of unload
49B	Motor overload - Fan #1	28VDC present = status OK, provides voltage back to PLC for Fan #1 overload status
49C	Motor overload - Fan #2	28VDC present = status OK, provides voltage back to PLC for Fan #2 overload status
52	Remote reset for burner control unit	120V = status OK, provides voltage to LME 69 reset
53	Upper grain paddle switch	24VDC present = Status dryer full
57	Soft start #1 fault	28VDC present = status OK, provides voltage back to PLC for overload status soft start #1
58	Soft start #2 fault	28VDC present = status OK, provides voltage back to PLC for overload status soft start #2

Wire Numbers & Uses – QuadraTouch Pro Tower Dryer

Common System Wires		
Wire #	Description	Use
59	Soft start #3 fault	28VDC present = status OK, provides voltage back to PLC for overload status soft start #3
61	DC control voltage to EMOV	1-10 VDC signal from PLC to EMOV
62	Static sample gate motor	28VDC from K22A relay to top side CB1 breaker
63	Static sample gate motor	28VDC from K22B relay to top side CB1 breaker
64	Static sample gate motor	28VDC to gate motor after unload is running reverses polarity through relays
65	Static sample gate motor	28VDC to gate motor after unload is running reverses polarity through relays
66	Static sample gate prox switch	28VDC present = status OK, provides voltage back to PLC for gate
70	RTD grain column temp signal wire	Provides signal from transmitter 0 – 5 volt DC reference voltage
71	RTD grain plenum temp signal wire	Provides signal from transmitter 0 – 5 volt DC reference voltage
73	RTD yellow wire plenum	Provides resistance signal from RTD measured in Ohms
74	RTD red wire plenum	Provides resistance signal from RTD measured in Ohms
76	RTD white wire grain column	Provides resistance signal from RTD measured in Ohms
77	RTD yellow wire grain column	Provides resistance signal from RTD measured in Ohms
80	Lower column over-temp sensor	28VDC present = status OK, provides voltage back to PLC for over temp status
81	Lower column over-temp sensor	28VDC present = status OK, provides voltage back to PLC for over temp status
82	Middle column over-temp sensor	28VDC present = status OK, provides voltage back to PLC for over temp status
83	Middle column over-temp sensor	28VDC present = status OK, provides voltage back to PLC for over temp status
84	Upper column over-temp sensor	28VDC present = status OK, provides voltage back to PLC for over temp status
85	Upper column over-temp sensor	28VDC present = status OK, provides voltage back to PLC for over temp status
94	Unload VFD ON signal	28VDC present = status OK, provides voltage back to PLC for VFD On
95	Common reference on PLC for 24V supply	24VDC ground. DC common
U	User fault circuit	24VDC = user fault OK – jumped out from factory.
D3	Moisture sensor blue, 0V to 3VDC temperature signal to PLC	Provides PLC with a voltage signal corresponding to temperature
D4	Moisture sensor black, 0 to 9VDC moisture signal to PLC	Provides PLC with a voltage signal corresponding to moisture
D5	Moisture sensor black, 0 to 9VDC moisture signal to PLC	Provides PLC with a voltage signal corresponding to moisture

Wire Numbers & Uses – QuadraTouch Pro Tower Dryer

Fan # 1		
Wire #	Description	Use
110	110V power from K2 Fan #1 relay to soft start & hour meter	110V present energizes Fan #1 contactor or soft start and supply power Fan #1
110A	28VDC from PLC to K2 Fan #1 relay	28VDC present energizes Fan #1 relay K2
111	110V power from K9 Fan #1 shunt trip relay	110V present energizes shunt trip Fan #1
111A	28VDC from PLC to K9 Fan #1 shunt trip relay	28VDC present energizes shunt trip relay K9
116	110V liquid gas solenoid ON	110V present energizes liquid gas solenoid
116A	24VDC K20 PLC liquid gas solenoid relay	24VDC present energizes main liquid gas solenoid relay K20
143	28VDC Fan #1 air pressure switch	28VDC from Fan #1 air switch to input on PLC
146	28VDC Fan #1 ON signal	28VDC from soft start to input on PLC

Fan # 2		
Wire #	Description	Use
210	110V power from K3 Fan #2 relay to soft start & hour meter	110V present energizes Fan #2 contactor or soft start and supply power Fan #2
210A	28VDC from PLC to K3 Fan #2 relay	28VDC present energizes Fan #2 relay K3
211	110V power from K10 Fan #2 shunt trip relay	110V present energizes shunt trip Fan #2
211A	28VDC from PLC to K10 Fan #2 shunt trip relay	28VDC present energizes shunt trip relay K10
243	28VDC Fan #2 air pressure switch	28VDC from Fan #2 air switch to input on PLC
246	28VDC Fan #2 ON signal	28VDC from soft start to input on PLC

Fan # 3		
Wire #	Description	Use
310	110V power from K4 Fan #3 relay to soft start & hour meter	110V present energizes Fan #3 contactor or soft start and supply power Fan #3
310A	28VDC from PLC to K4 Fan #3 relay	28VDC present energizes Fan #3 relay K4
311	110V power from K11 Fan #3 shunt trip relay	110V present energizes shunt trip Fan #3
311A	28VDC from PLC to K11 Fan #3 shunt trip relay	28VDC present energizes shunt trip relay K11
343	28VDC Fan #3 air pressure switch	28VDC from Fan #3 air switch to input on PLC
346	28VDC Fan #3 ON signal	28VDC from soft start to input on PLC

Fan # 4		
Wire #	Description	Use
410	110V power from K23 Fan #4 relay to soft start & hour meter	110V present energizes Fan #4 contactor or soft start and supply power Fan #4
410A	28VDC from PLC to K23 Fan #4 relay	28VDC present energizes Fan #4 relay K23
411	110V power from K24 Fan #4 shunt trip relay	110V present energizes shunt trip fan #4
411A	28VDC from PLC to K24 Fan #4 shunt trip relay	28VDC present energizes shunt trip relay K24
415A	28VDC static sampler	28VDC present energizes relay K22A & K22B static sample relay
443	28VDC Fan #4 air pressure switch	28VDC from Fan #4 air switch to input on PLC
446	28VDC Fan #4 ON signal	28VDC from soft start to input on PLC

Tower Dryer PLC Setup

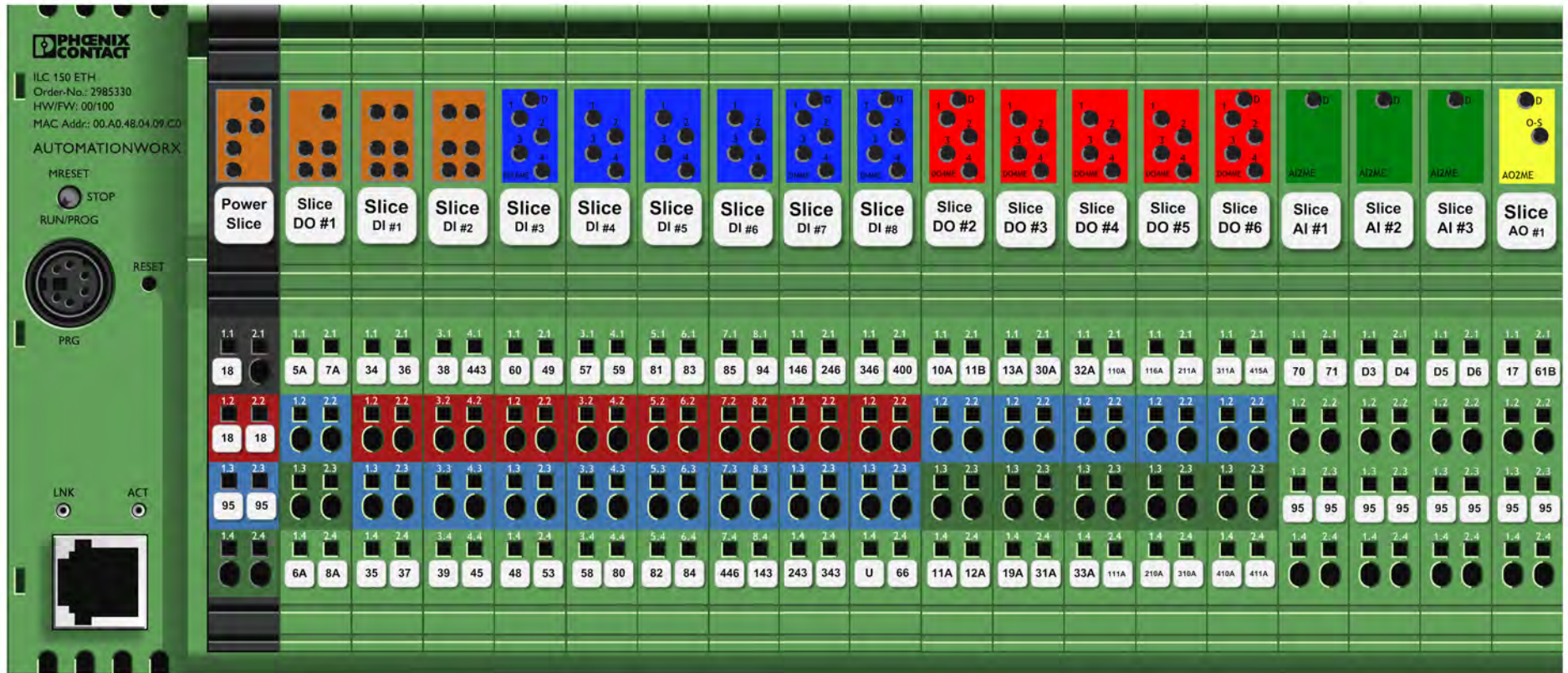

Title:	Tower Dryer PLC Setup
Author:	SUKUP MFG CO - MRK
Date:	8/15
Sheet:	101.4
Revision:	

Emergency Stop and System Control Switch Wiring

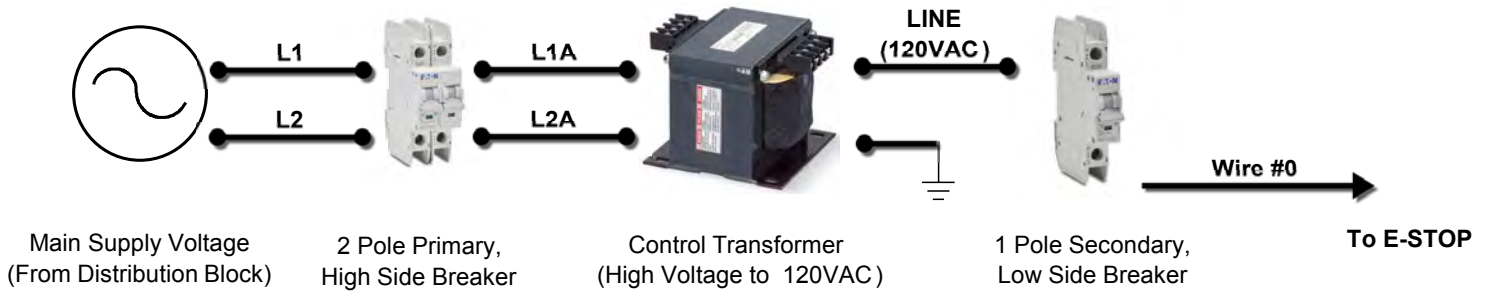

NOTE: 575VAC is Fused Instead of 2 Pole breaker shown

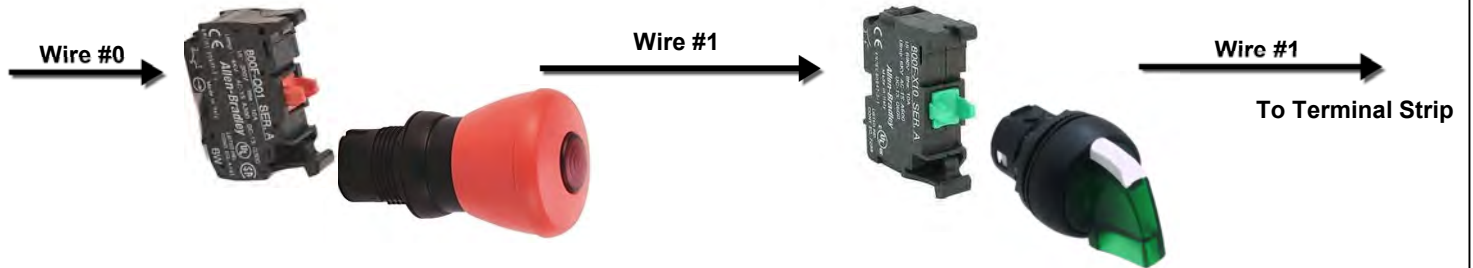

**E-STOP
(Emergency Stop Switch)**

**System Control Switch
Manual ---- OFF ---- Auto
(3 Position)**

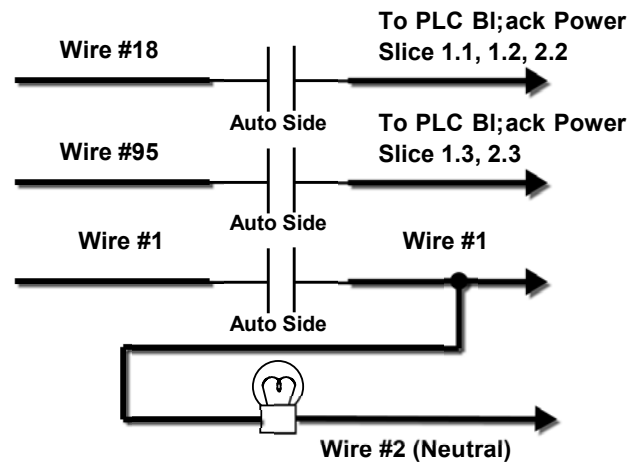
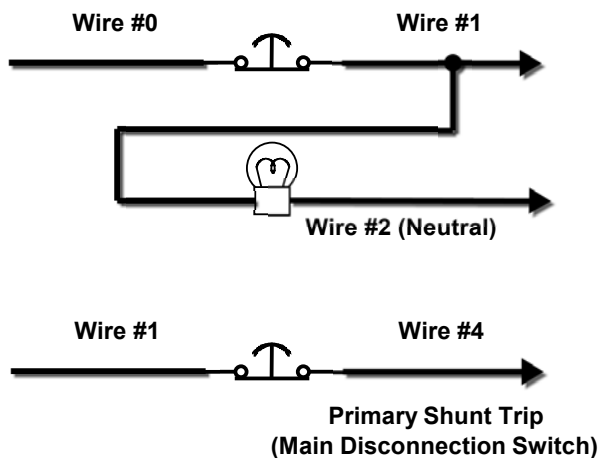

Title: Tower Dryer: Emergency Stop and System Control Switch Wiring

Author: SUKUP MFG CO - MRK

Date: 06/16

Sheet: 101.5

Revision: 8/17/2017 - DWS (1)

Altivar 312 Tower VFD Control Wiring



- #95 Black → COM
- #17 Gray → AI1
- #10D Blue → LI1
- #18 Orange → R1C & R2C
- #49A Purple → R1A
- #94 Purple → R2A

K21 Relay Pin#14

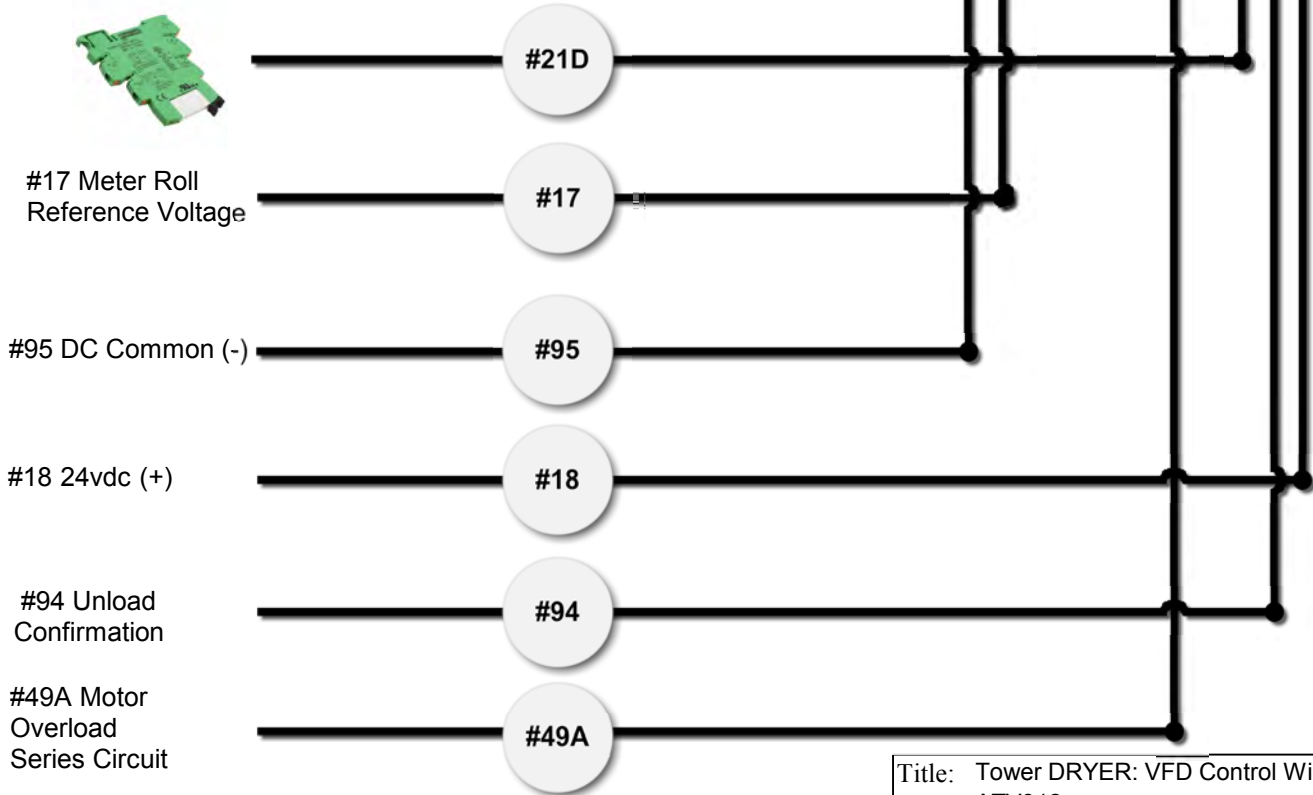

Title: Tower DRYER: VFD Control Wiring
ATV312

Author: SUKUP MFG CO - MRK

Date: 06/16

Revision:

107.5

Heater Control Unit LME69.200C1BM

Factory Jumper Installed between 25, 26, and 27 in
Pipe Train Junction Box on Mod Towers ONLY

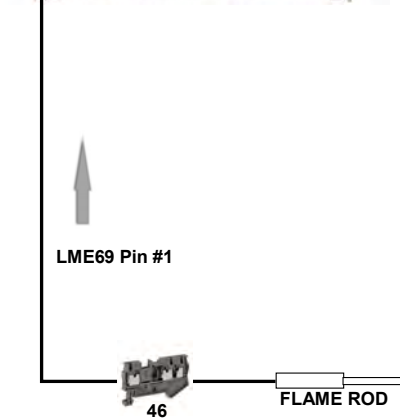
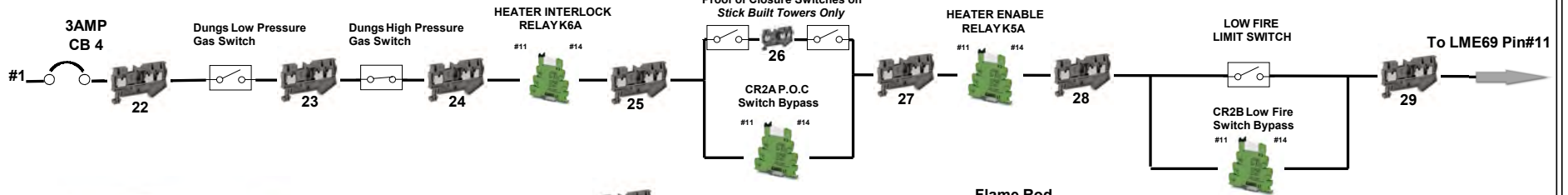

Main Gas Valve Relay

#A1 -- 116A from PLC
#A2 -- Coil return #95
#11 -- 120VAC
#14 -- To Main Gas Valve Coil (120VAC)

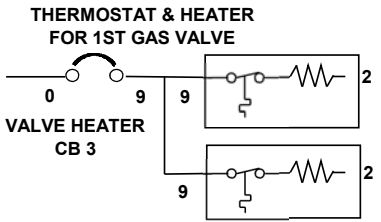
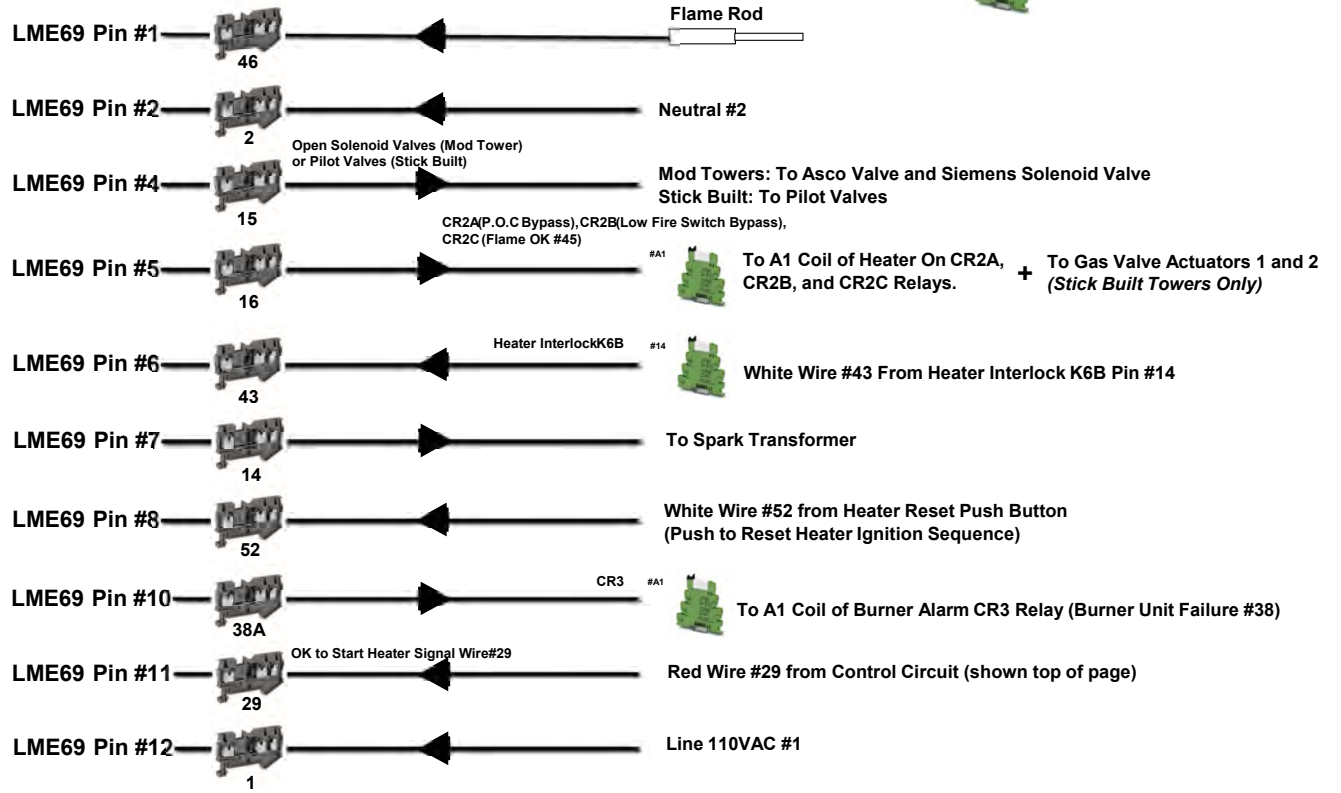

Title: Tower Dryer Heater Control Unit - LME69	
Author: SUKUP MFG CO - MRK	
Date: 11/15	Sheet: 107.12
Revision:	

Sukup Electronic Modulating Valve Actuator- J62281

Electronic Actuator
(EMOV) J62281



The EMOV actuator opens and closes the stem valve on the gas section of the pipe train. The PLC controls the position of the stem valve with the DC reference signal on Pin Y (Wire#61). When the valve is not being controlled, its reference position should be the low fire position (factory default 1.5vdc).

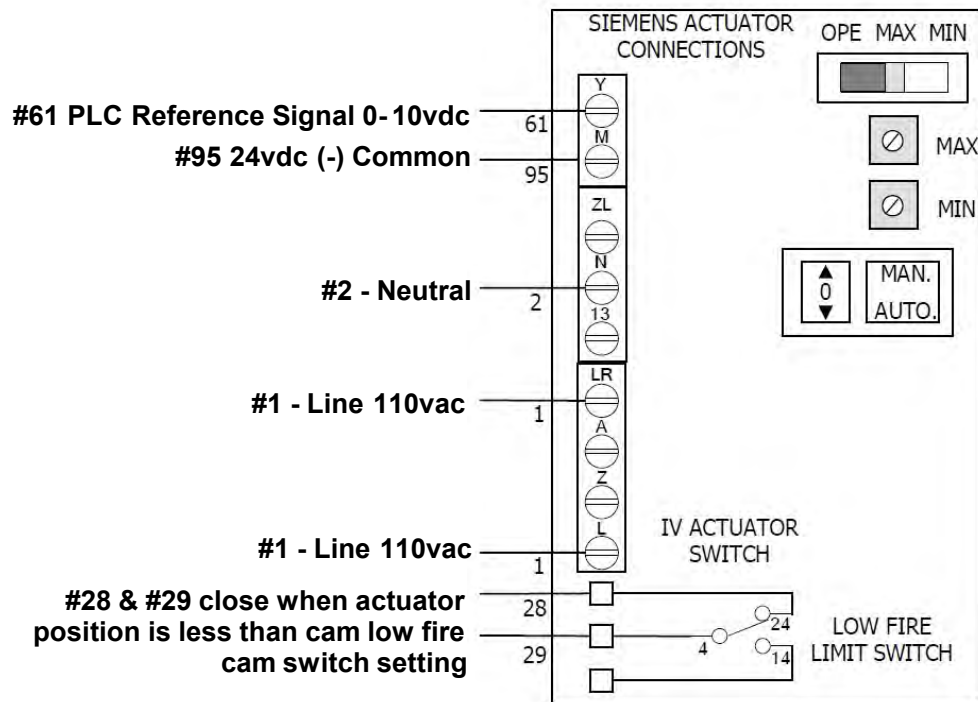

Low Fire Switch Cam #4 (20) →

Loss of Signal Cam #3 (0) →

Min Opening Cam #2 (0) →

Max Opening Cam #1 (85) →



Title: Sukup Electronic Modulating Valve Actuator (EMOV) J62281	
Author: SUKUP MFG CO - MRK	
Date: 9/2015	Sheet: 107.14
Revision: 7/2016	

Sukup Electronic Modulating Valve Actuator- J6124

Electronic Actuator
(EMOV) J6124



Left to Right
Pin 1: #95
Pin 2: #18
Pin 3: DC Reference
Pin 4: Not Used

The EMOV actuator opens and closes the stem valve on the vapor section of the pipe train. The PLC controls the position of the control valve with the DC reference signal on Pin 3.

The EMOV actuator also has a clip-on Low Fire Switch on modular Tower Dryers. This ensures that the stem valve has returned to its low-fire position to provide safe burner lighting.



Low Fire Switch Pinout
Purple #S1 - Wire #28
Red #S2 - Wire #29
White #S3 - Not Used

Title:	Sukup Electronic Modulating Valve Actuator (EMOV)		
Author:	SUKUP MFG CO - MRK		
Date:	6/2016	Sheet:	107.16
Revision:			

TOWER – STATIC MOISTURE SAMPLE BOX

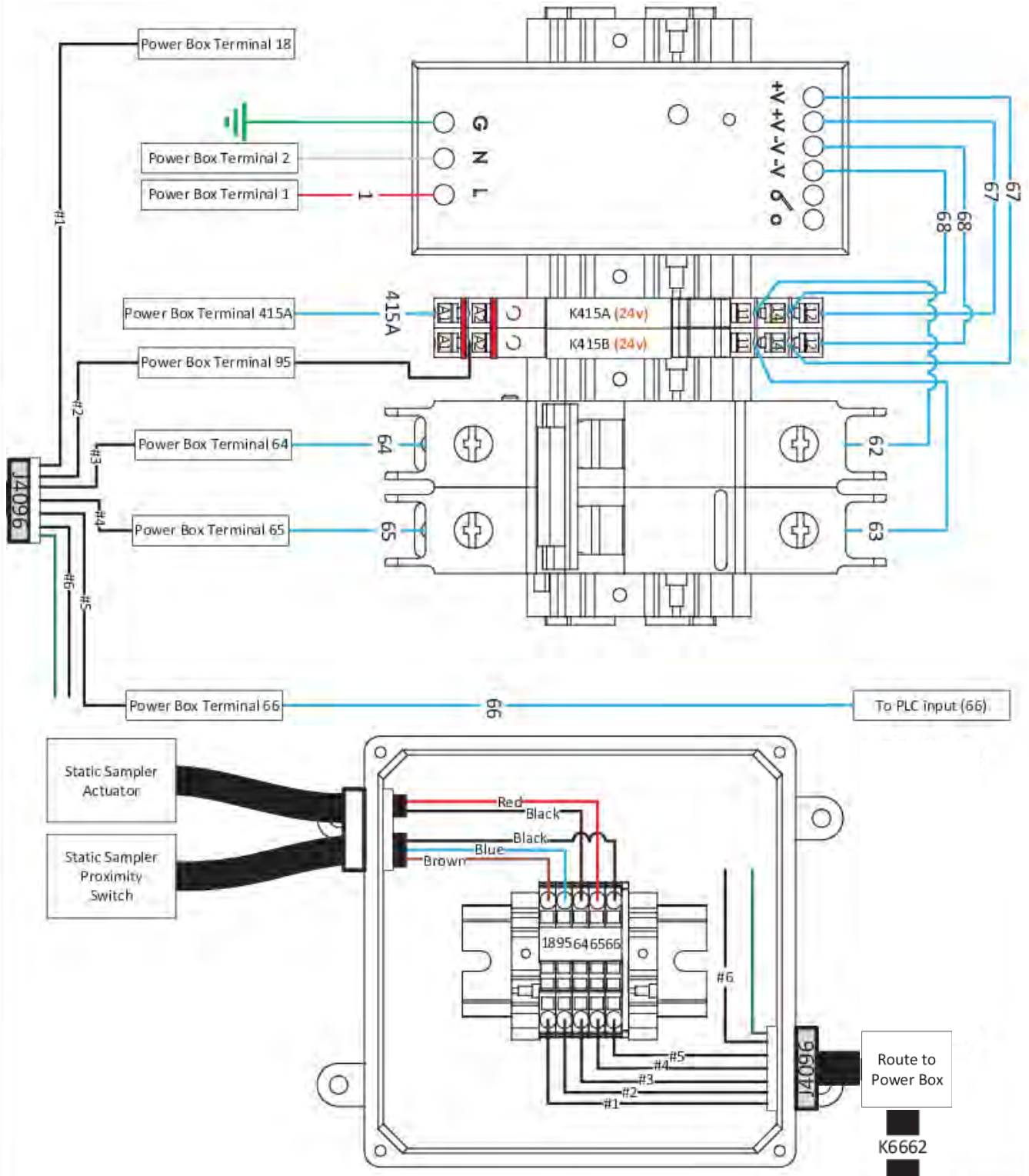

Title: TOWER – STATIC MOISTURE SAMPLE BOX

Author: SUKUP MANUFACTURING CO.

Date: 6/16

Sheet: 107.18

Revision: 10/20/2021 EM/JTB

Heater Pipe Train Junction Box Wiring

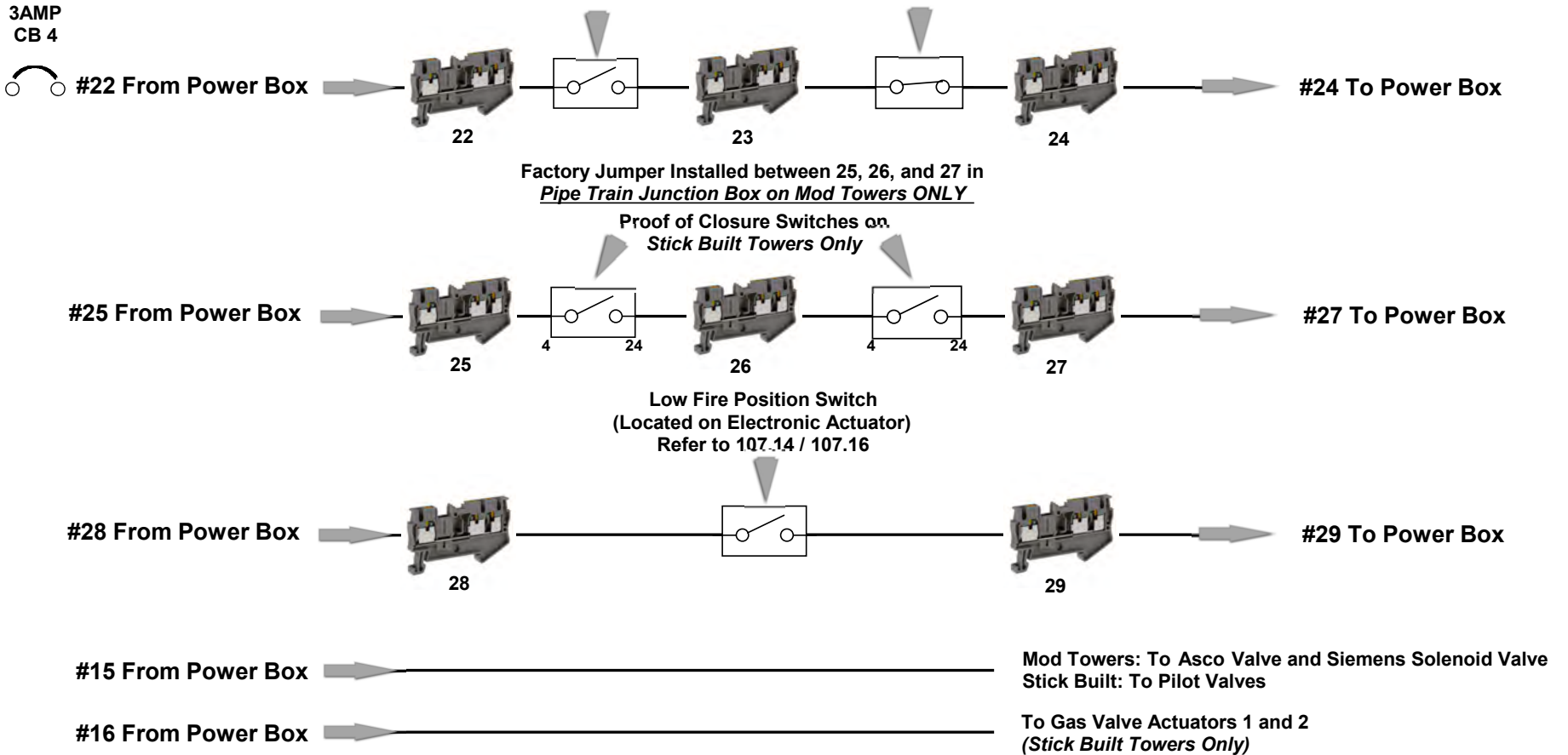

Factory Jumper Installed between 25, 26, and 27 in Pipe Train Junction Box on Mod Towers ONLY

Proof of Closure Switches on *Stick Built Towers Only*

Low Fire Position Switch
 (Located on Electronic Actuator)
 Refer to 107.14 / 107.16

Main Gas Valve Relay



#A1 -- 116A from PLC
 #A2 -- Coil return #95
 #11 -- 120VAC
 #14 -- #116 To Main Gas Valve Coil (120VAC)

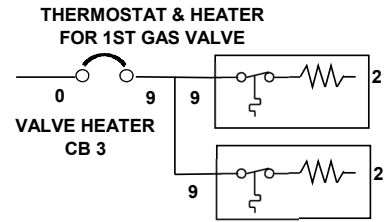

Title: Tower Dryer - Heater PipeTrain Junction Box	
Author: SUKUP MFG CO - MRK	
Date: 6/16	Sheet: 107.19
Revision:	

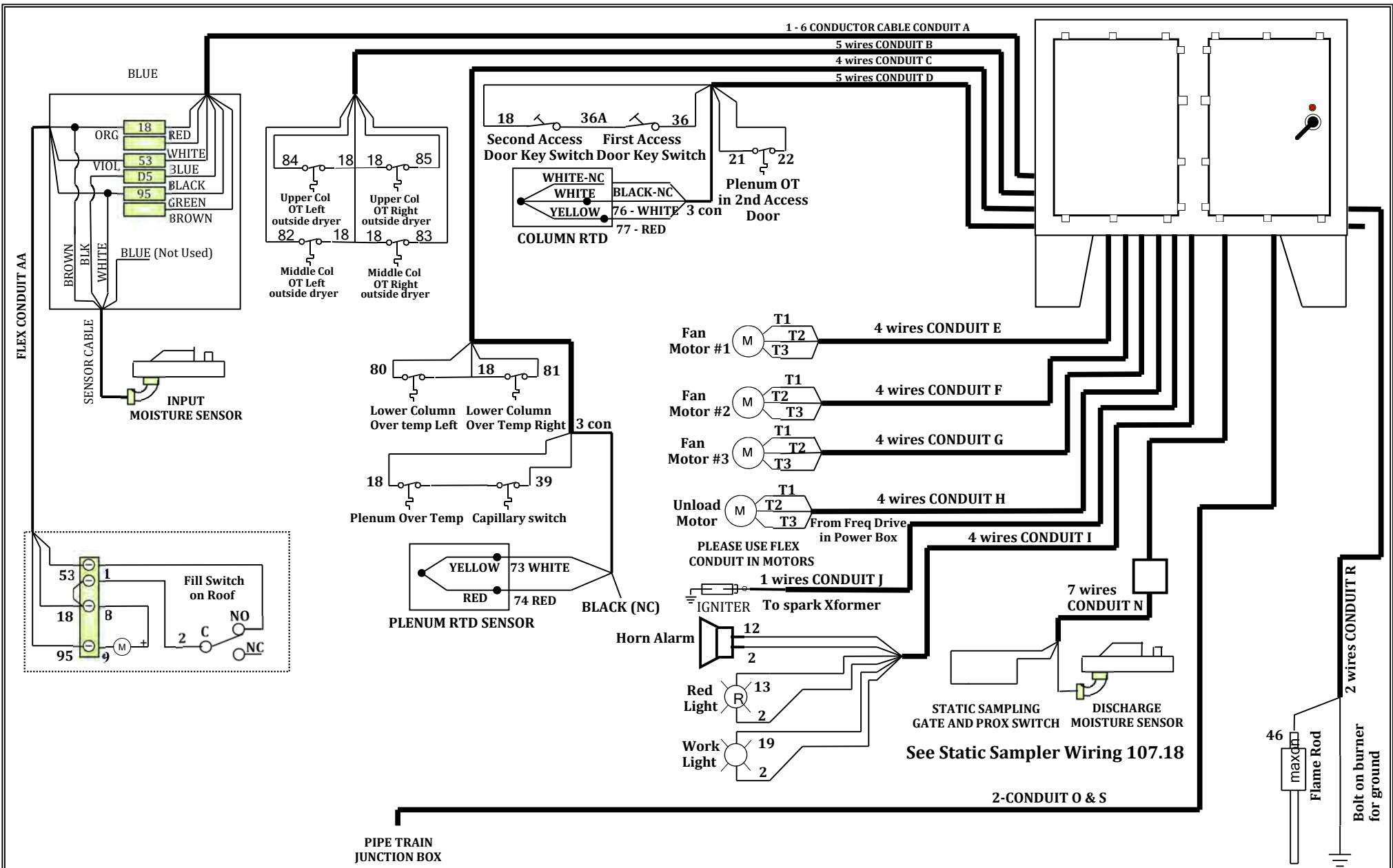

See Heater Junction Box
Wiring SHEET 107.19

Title: Sukup Mfg Co. Tower Dryer Installation Wiring	
Author: Sukup Mfg. Co.	
Date: 07/16	Sheet: 107.20
Revision:	

PLC DI SLICE #1 (Load/Unload Interlock Circuits #34, #35)

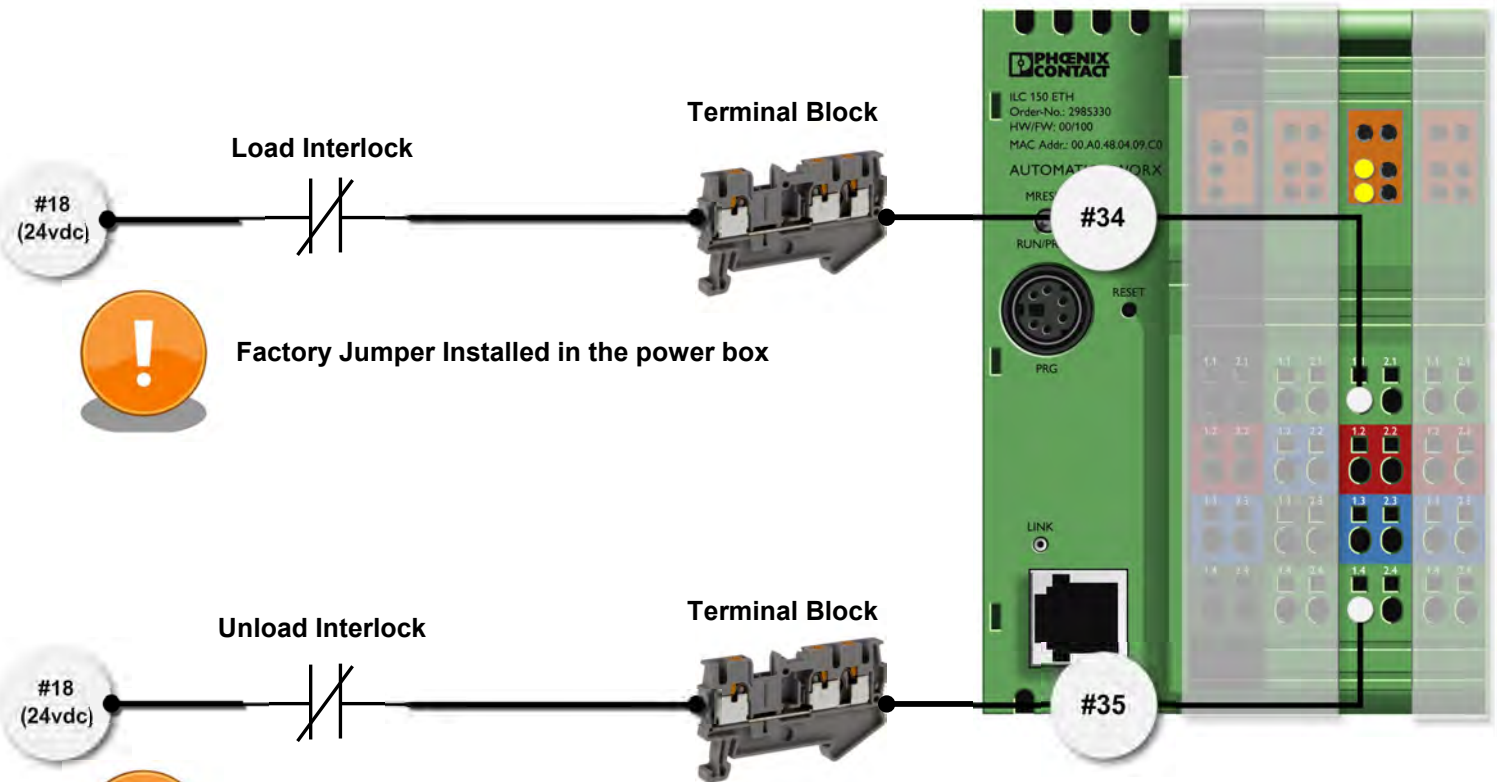

Factory Jumper Installed in the power box



Factory Jumper Installed in the power box



The customer load and unload interlock circuits must have 24vdc on wire # 34 and #35 respectively. Typically, these circuits are used as a safety interlock to tell the PLC that it's safe to load or unload the dryer. If the load circuit (#34) does not have DC voltage on it, the load will be unable to run. If the unload circuit (#35) does not have DC voltage on it, the unload will still run, but will shutdown after a 7 minute timeout period has expired. The 7 minute timer is also displayed on-screen if applicable.

Title: Tower Dryer Customer Load/Unload Circuits

Author: SUKUP MFG CO - MRK

Date: 8/15

Sheet: 108.1

Revision: 6/7/2017 - DWS (1)

PLC DI SLICE #1 Access Door Fault #36

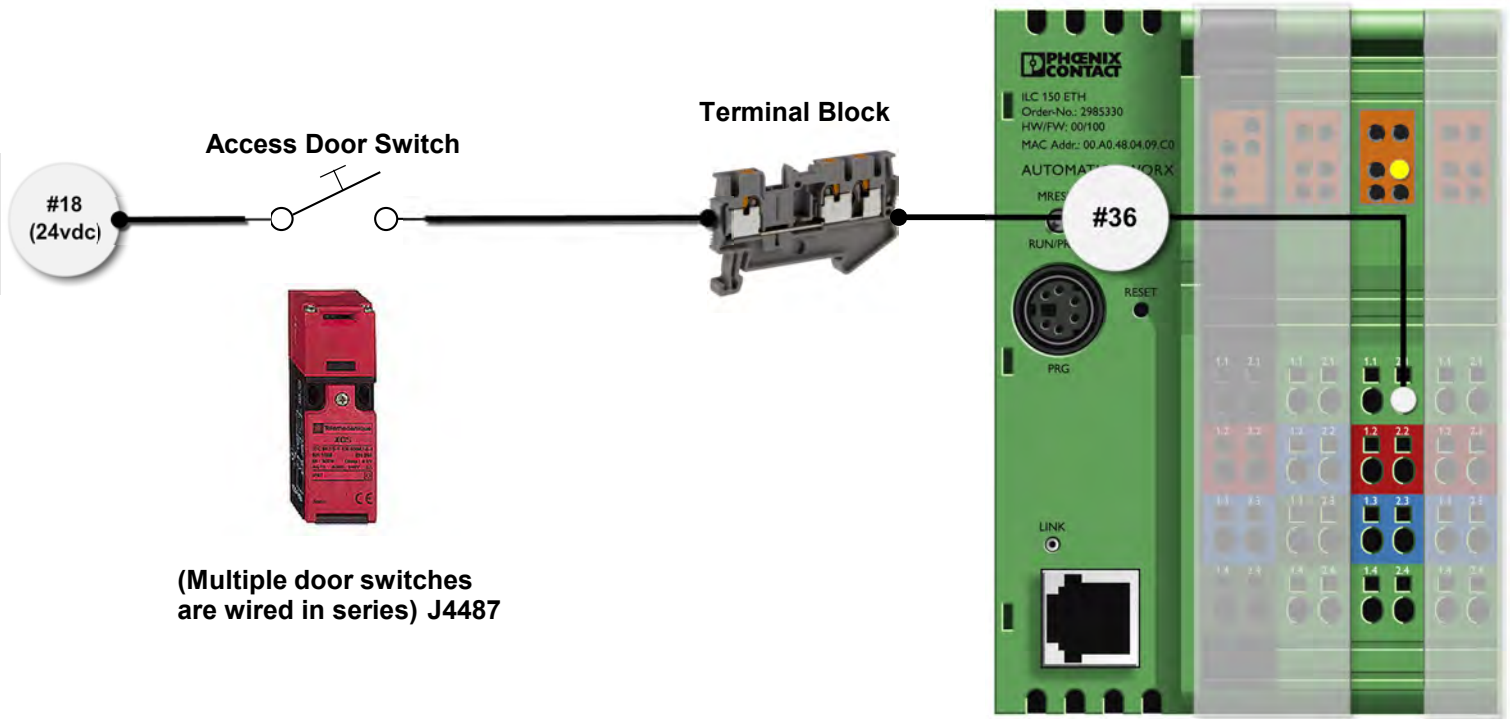

The Access Doors on the tower dryer are required to be shut for operation. Multiple doors are wired in series. The door switch requires the key to be inserted in normal operation, thus sending 24vdc back to the PLC.

Title: Tower DRYER: Access Door Fault #36	
Author: SUKUP MFG CO - MRK	
Date: 08/15	Sheet: 108.2
Revision: 6/7/2017 - DWS (1)	

PLC DI SLICE #1 Vapor Over-Temp #37

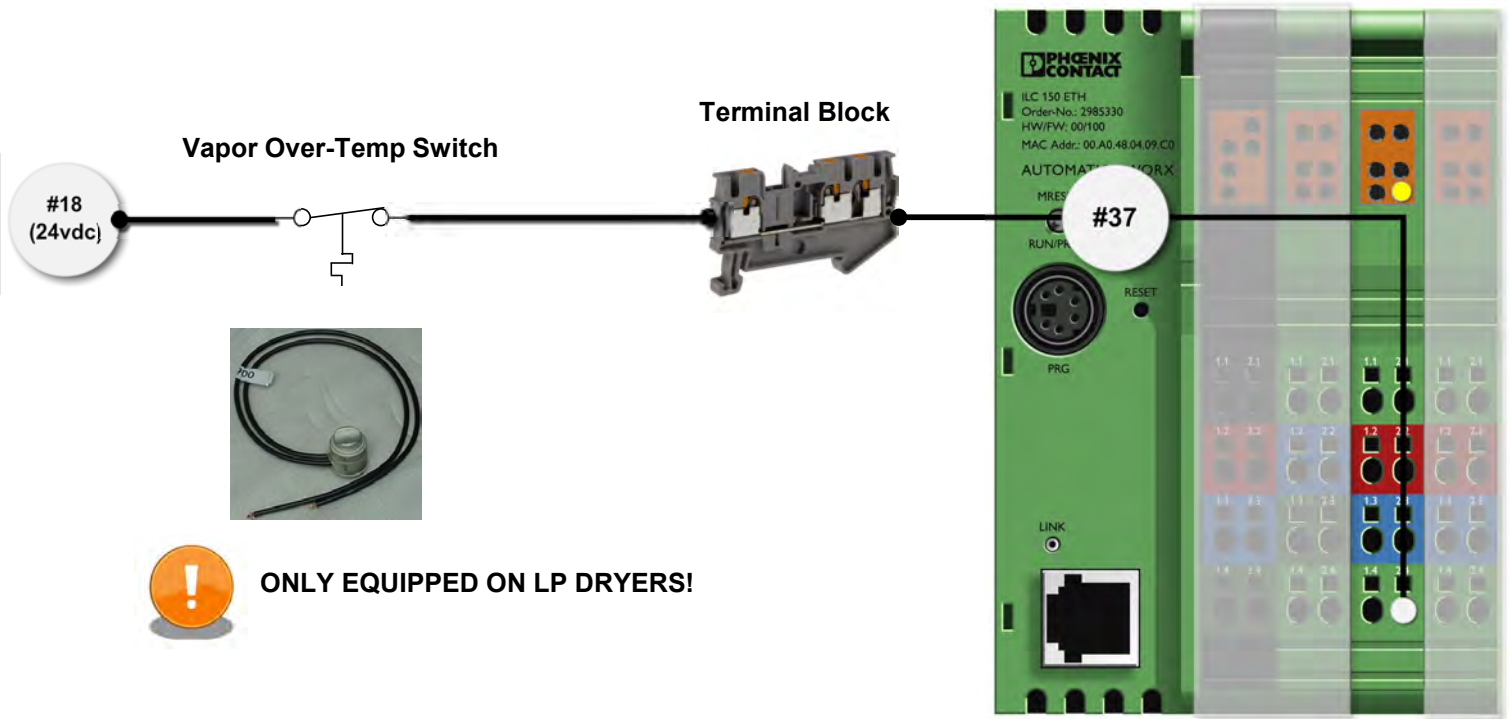

The Vapor Over-Temp switch monitors the temperature of the LP vapor. If the temperature rises above 140°F, the switch opens and the circuit loses its 24vdc - causing a fault condition.

Title: Tower DRYER: Vapor Over-Temp #37

Author: SUKUP MFG CO - MRK

Date: 08/15

Sheet: 108.3

Revision: 6/7/2017 - DWS (1)

PLC DI SLICE #2 Burner Unit Failure #38

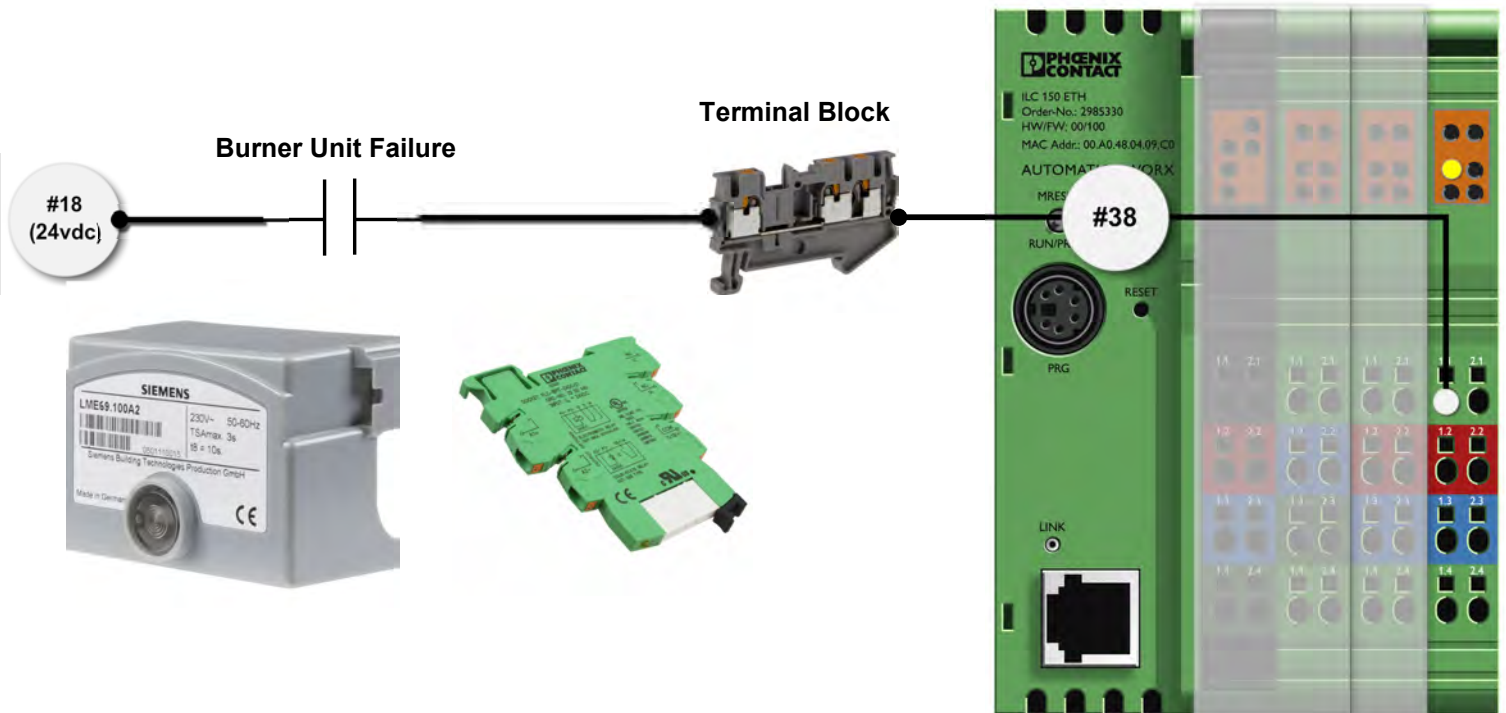

The Burner Unit Controller has a programmable output to tell the PLC if there is a problem with the ignition sequence or burner operation. Pin #10 on the LME69 will pull in the CR3 relay (120vac), sending 24vdc to wire #38. If the PLC sees 24vdc on wire #38, the dryer will shut down if the dryer is trying to unload (#94 ON). Otherwise, the unit can be reset without shutting the dryer down.

Title: Tower DRYER: Burner Unit Failure #38

Author: SUKUP MFG CO - MRK

Date: 08/15

Sheet: 108.4

Revision: 6/7/2017 - DWS (1)

PLC DI SLICE #2 Plenum Overtemp #39

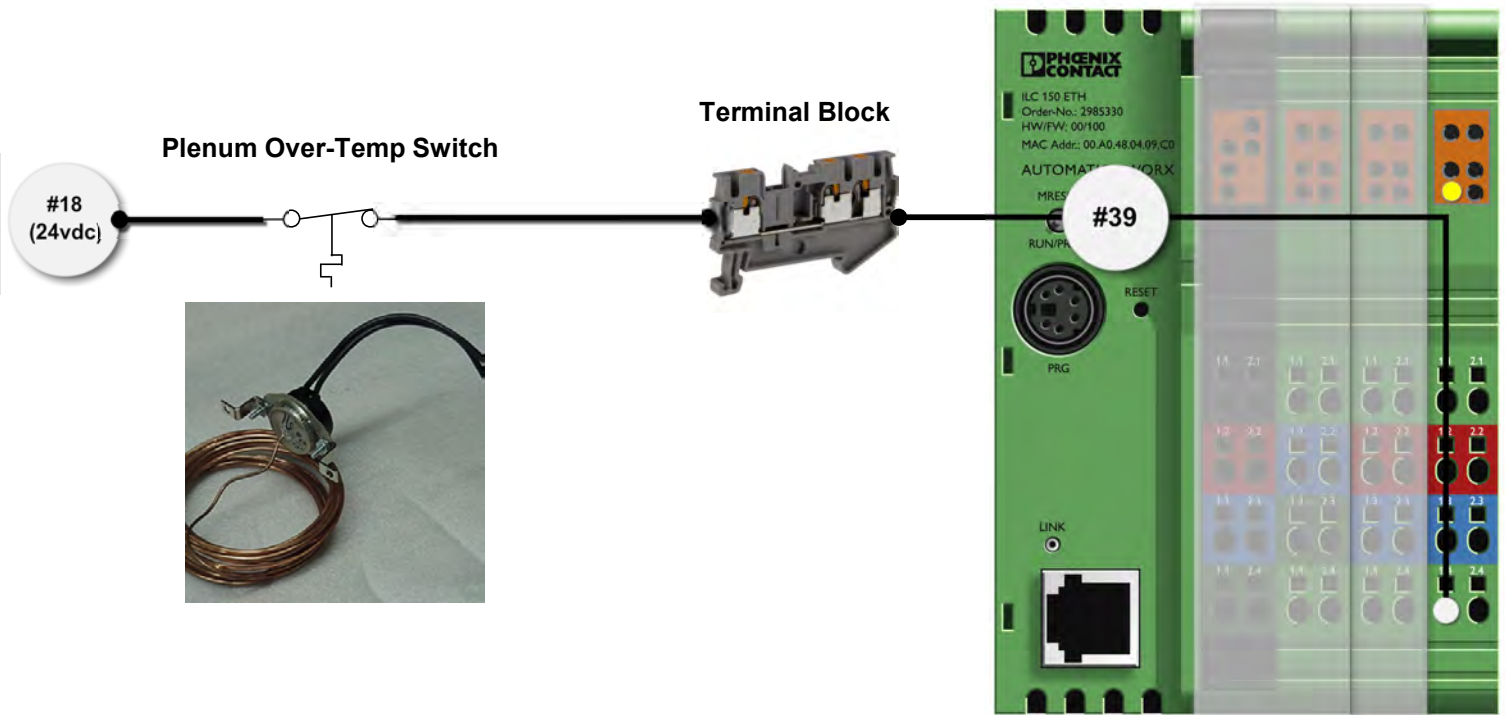

The Plenum Over-Temp Switch is a capillary switch that opens its circuit when any part of the sensor sees at temperature greater than 325°F. Loss of 24vdc on this circuit will cause and immediate shutdown.

Title: Tower DRYER: Plenum Overtemp #39	
Author: SUKUP MFG CO - MRK	
Date: 08/15	Sheet: 108.5
Revision: 6/7/2017 - DWS (1)	

PLC DI SLICE #2 Flame Signal #45

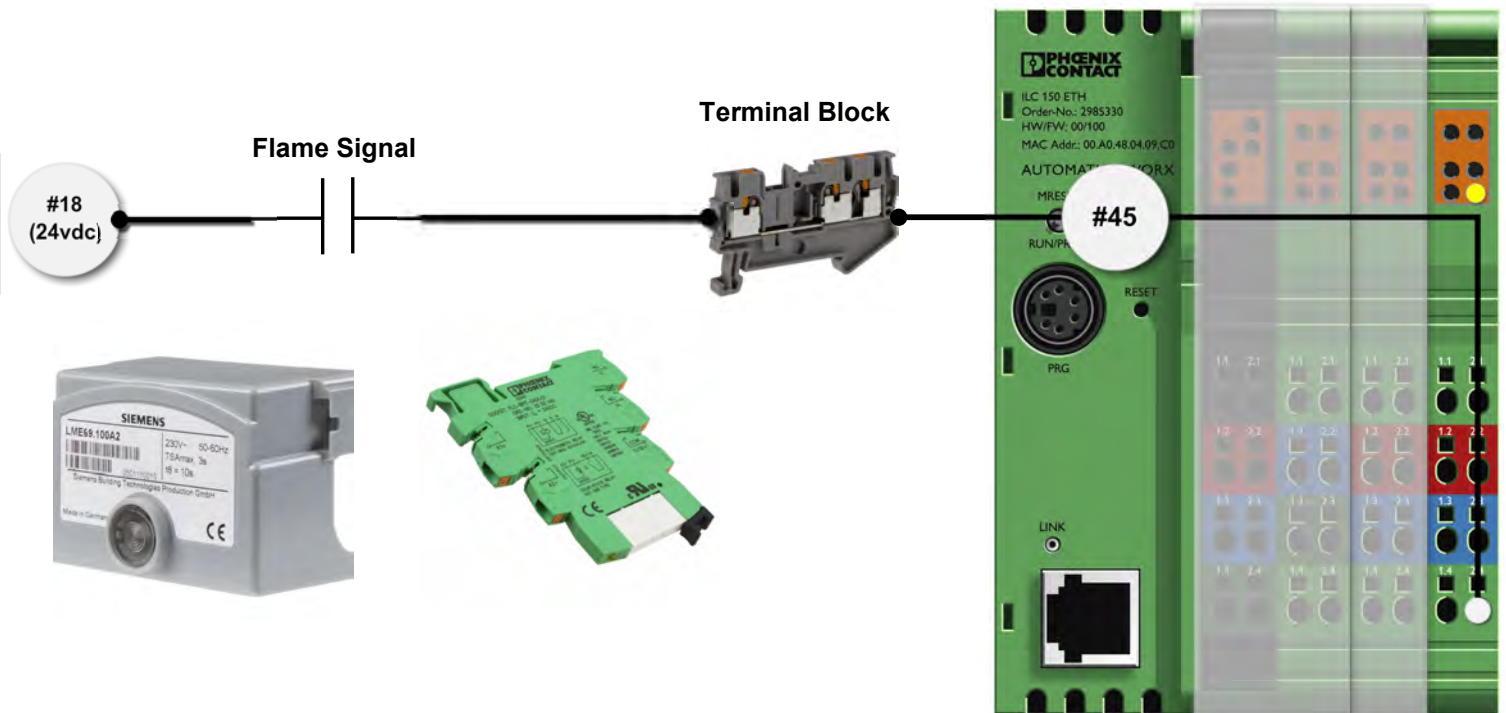

The Flame Circuit starts as a signal that is monitored by the Burner Control unit. The Burner Control unit is connected to a Flame Rod located inside the tower dryer at the heating element. When Flame is sensed, a 120VAC output is sent from the Burner Control unit to a PLC relay, converting the signal to 24Vdc, and input into the PLC on wire #45.

Title: Tower DRYER: Flame Signal #45

Author: SUKUP MFG CO - MRK

Date: 08/15

Sheet: 108.6

Revision: 6/7/2017 - DWS (1)

Tower Dryer Soft Start Fault #57, #58, #59, #60

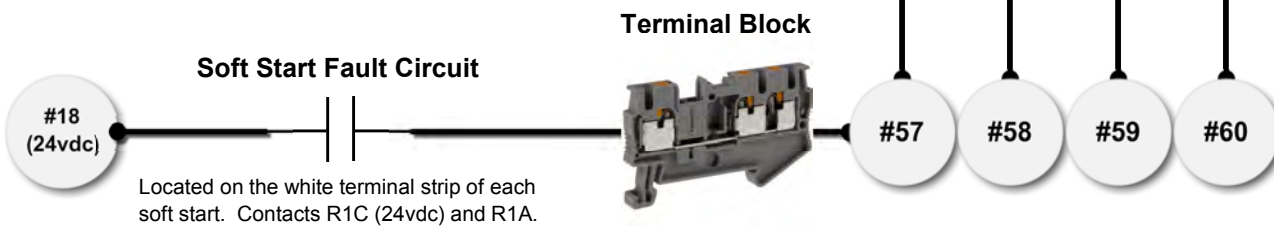
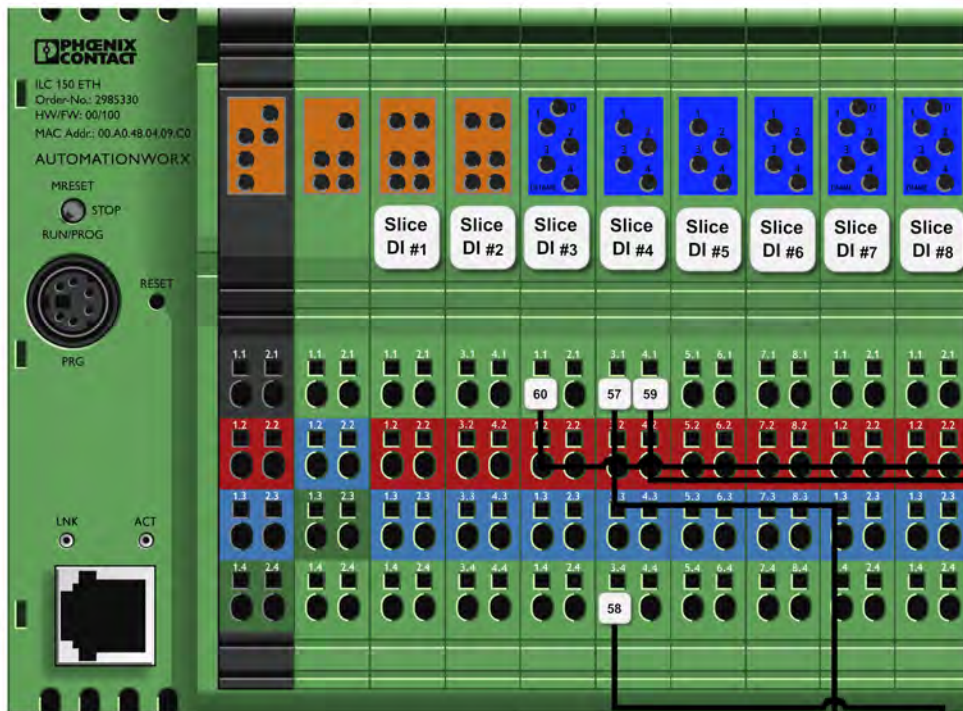

The Soft Start Fault Circuit is designed to monitor each soft start for any failures. In the event the soft start faults, the contact on R1A opens, and the dryer will shutdown.

Title: Tower DRYER: Soft Start Fault Circuit	
Author: SUKUP MFG CO - MRK	
Date: 8/15	
Revision: 6/7/2017 - DWS (1)	108.7

Tower Dryer Column Over-Temp Fault #80, #81, #82, #83, #84, #85

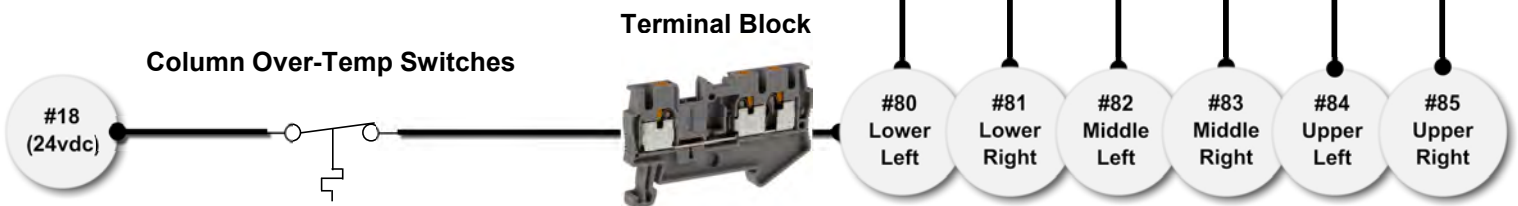
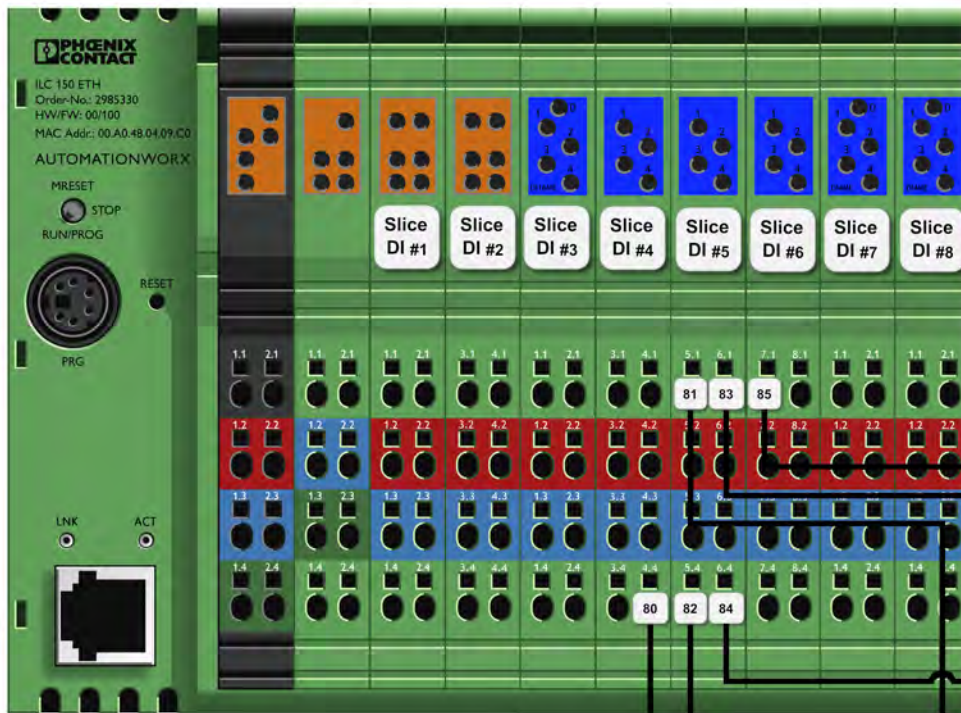

Located on the outside columns of the tower dryer in plastic junction boxes



The Column Over-Temp fault circuit monitors the temperature of the grain inside the column. Each of these circuits will open if the temperature rises above 240°F. Modular Tower Dryers are not equipped with middle column over-temp switches. Therefore signals #82 and #83 are not used on these models.

Title: Tower DRYER: Column Over-Temp	
Author: SUKUP MFG CO - MRK	
Date: 8/15	
Revision: 6/7/2017 - DWS (1)	108.8

Tower Dryer User Input Timeout

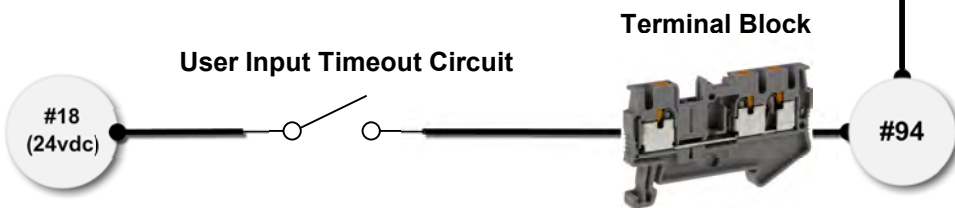
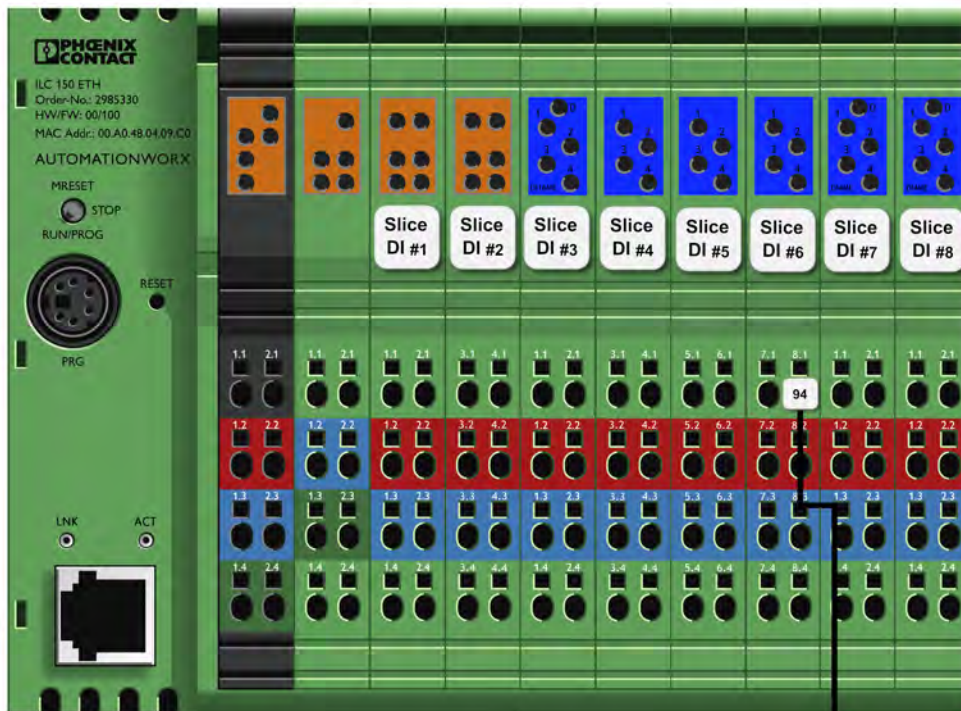

The User Input Timeout Fault happens when the system is expecting information to be entered into the touchpanel, but it is never received. This most frequently happens when the unload table is paused but never restarted before the timer expires.

Title: Tower DRYER: Unload User Timeout

Author: SUKUP MFG CO - MRK

Date: 8/15

Revision:

108.9

Tower Dryer Air Switch Circuit #143, #243, #343, #443

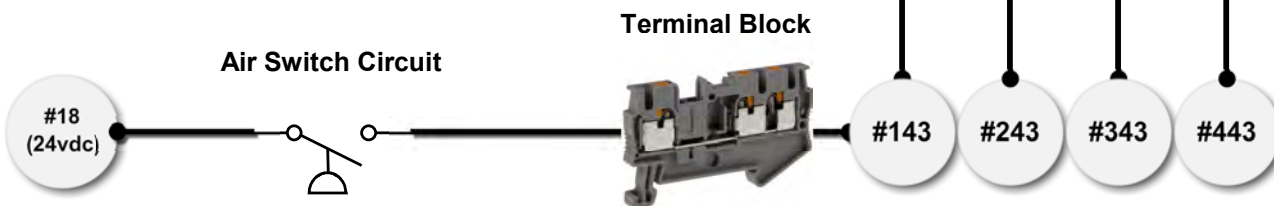
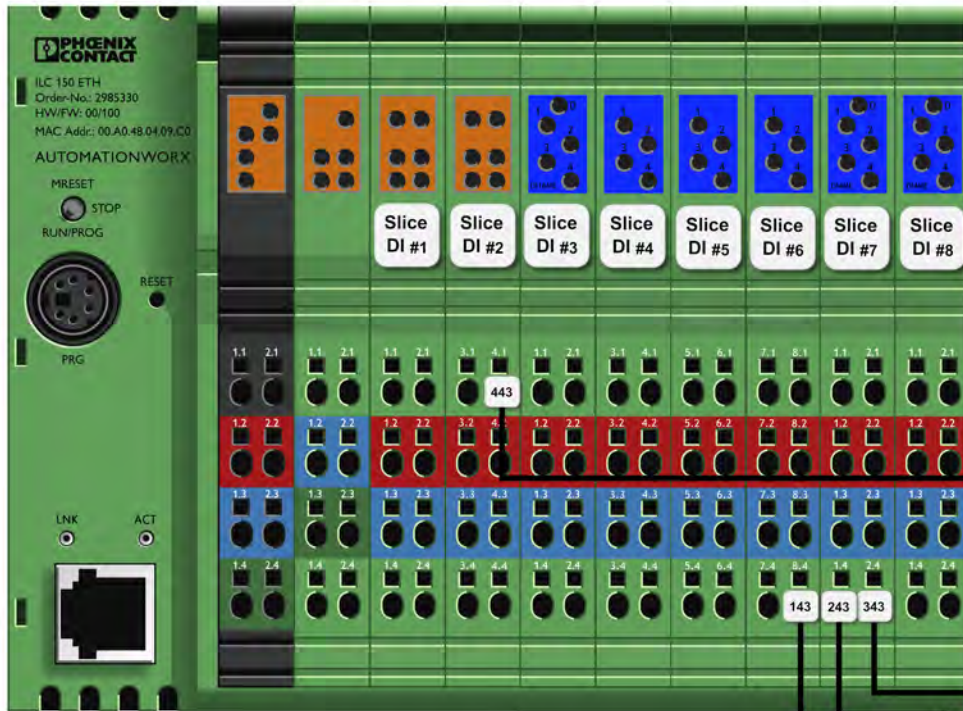

Air Tube runs from bottom of blower(s) to switch located in power box.



The air switch circuit monitors the static pressure level of the blower(s). The negative pressure created by the rotating fan(s) causes the switch to close, telling the PLC that the blower is running.

Title: Tower DRYER: Air Switch Circuit	
Author: SUKUP MFG CO - MRK	
Date: 8/15	
Revision: 6/7/2017 - DWS (1)	108.10

Tower Dryer Fan Confirmation Circuit #146, #246, #346, #446

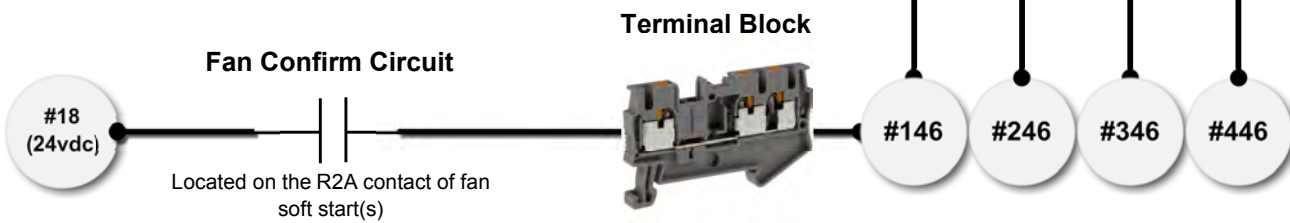
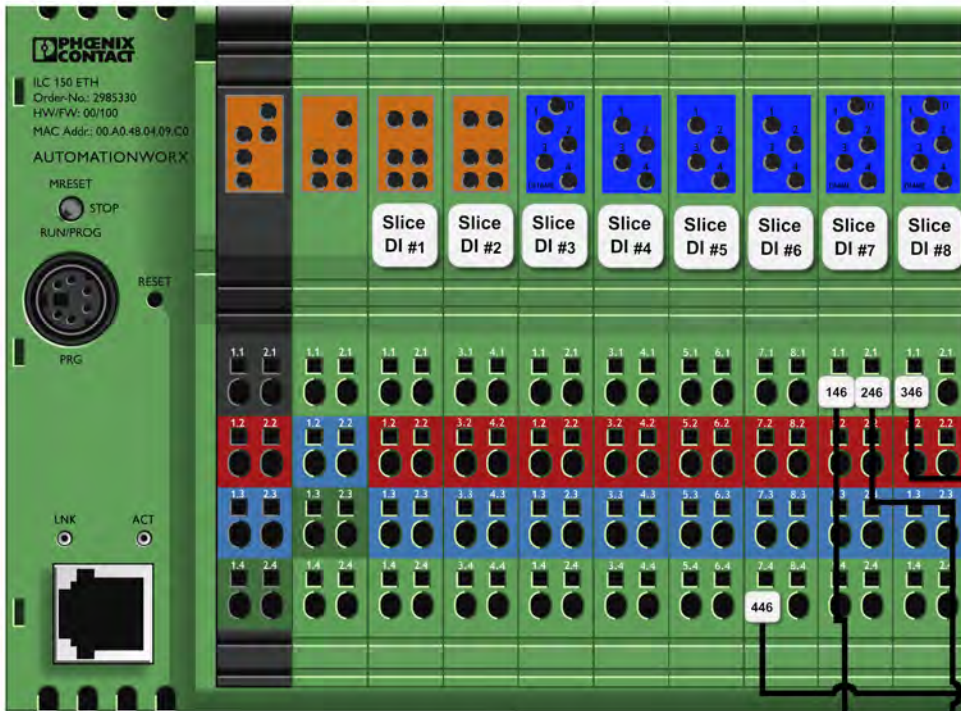

The fan confirmation circuit tells the PLC that the soft start is finished with its ramp and in full run mode. This signal needs to come back to the PLC or a strange I/O combination error will be present.

Title: Tower DRYER: Fan Confirmation Circuit

Author: SUKUP MFG CO - MRK

Date: 8/15

Revision: 6/7/2017 - DWS (1)

108.11

Tower Dryer MST Prox Circuit #66

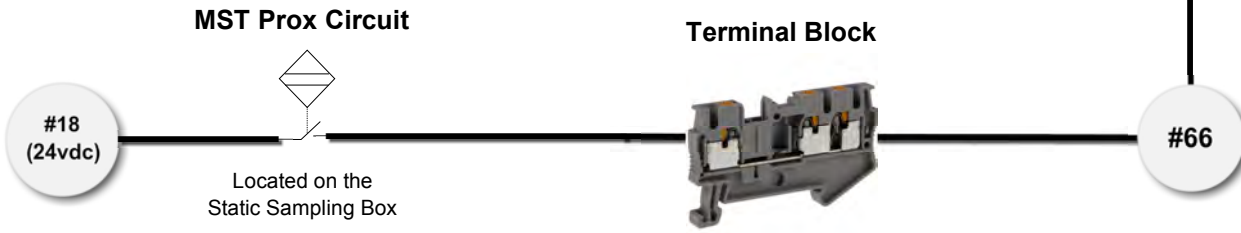
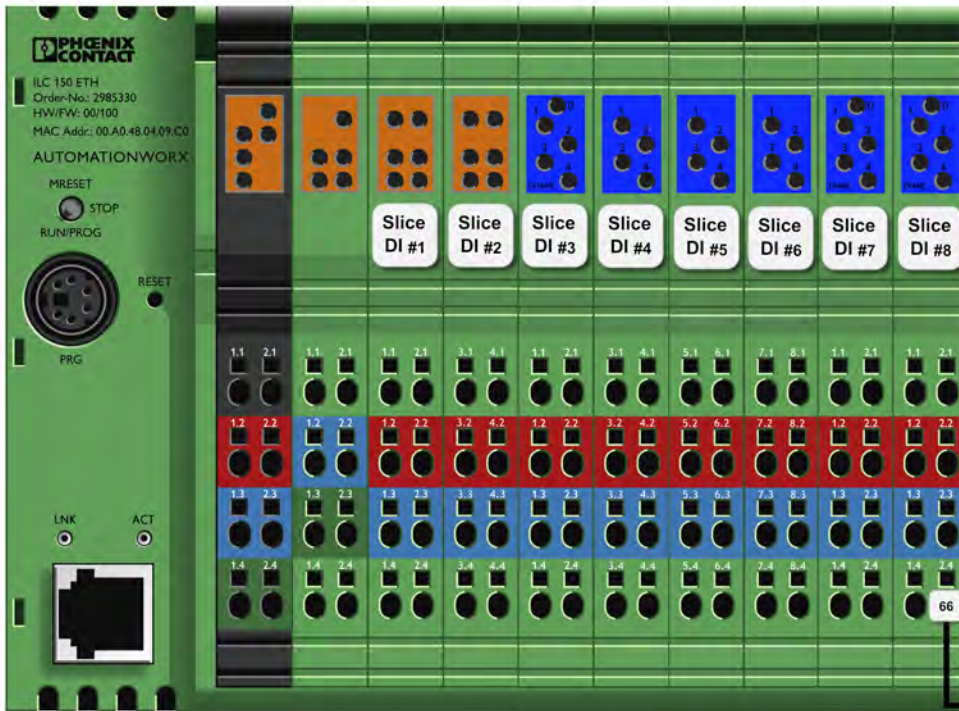

The MST Prox Circuit is monitored when the tower dryer is unloading and sampling grain. Every time the dryer tells the static sampling device to close the sample gate, the MST prox detects for gate closure. When the gate is told to close, but the MST prox doesn't register a gate closure, this fault is displayed on the screen.

Title: Tower DRYER: Moisture Sensor Prox Switch

Author: SUKUP MFG CO - MRK

Date: 8/15

Revision: 6/7/2017 - DWS (1)

108.12

Tower Dryer Fill Switch #53 Out of Wet Grain Fault, Fill Timer Fault

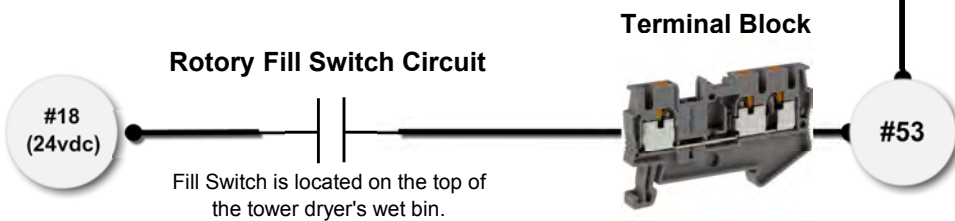
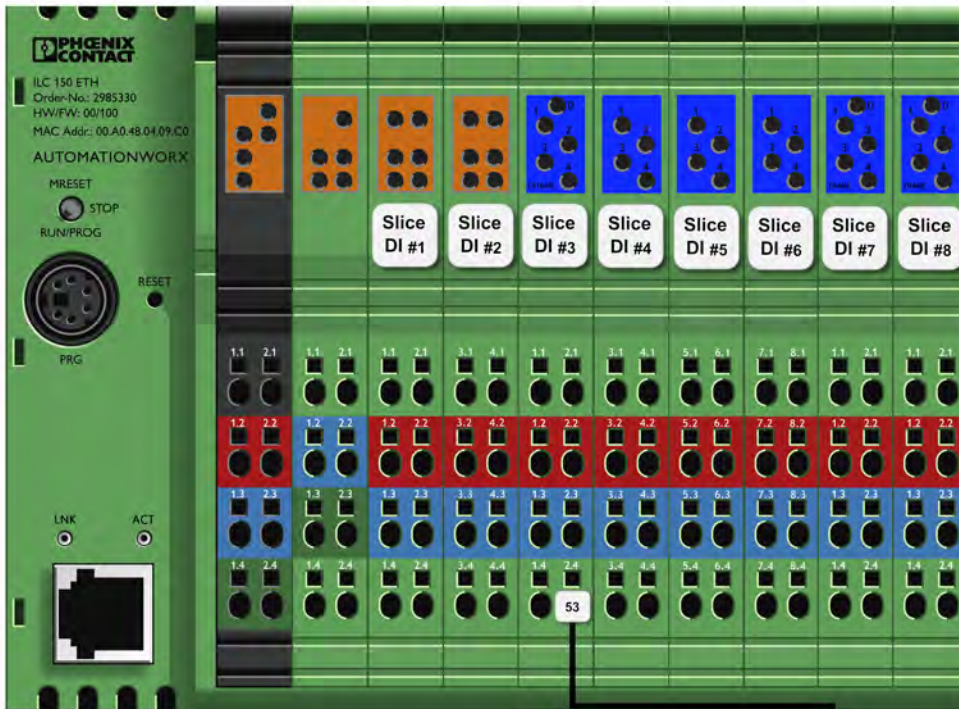

The Rotary Fill Switch is located on the top of the tower dryer and tells the PLC when to energize the load auxiliaries (5A, 6A, 7A, 8A). When the switch is rotating, opening the #53 circuit, the dryer energizes the load auxiliary equipment. When the switch is not rotating, indicating that the paddle is surrounded by grain, the dryer stops the load auxiliaries so as not to overfill the system. When the dryer stops on a fill timer fault, the dryer has been unloading for 15 min (system default, user selectable) without opening the #53 circuit. When the dryer stops on an Out of Wet Grain Fault, the dryer has been running for 10 min (system default, user selectable) without making the #53 circuit. Both the Fill Timer and Out of Wet Grain Timers are displayed on-screen during operation.



Fill Switches tend to change from time to time, Actual switch may differ from picture..

Title: Tower DRYER: Fill Switch #53 Out of Wet Grain Fault, Fill Timer Fault	
Author: SUKUP MFG CO - MRK	
Date: 8/15	
Revision: 6/7/2017 - DWS (1)	108.13

Tower Dryer User Fault #U

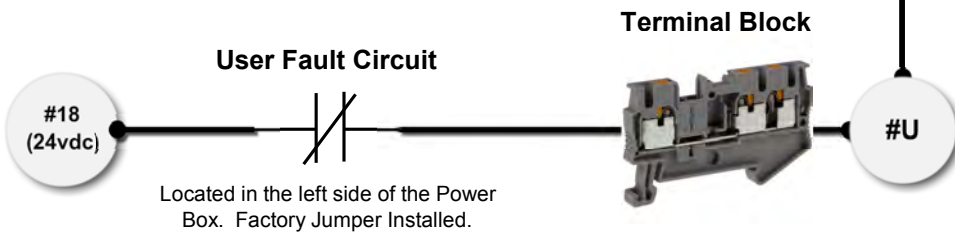
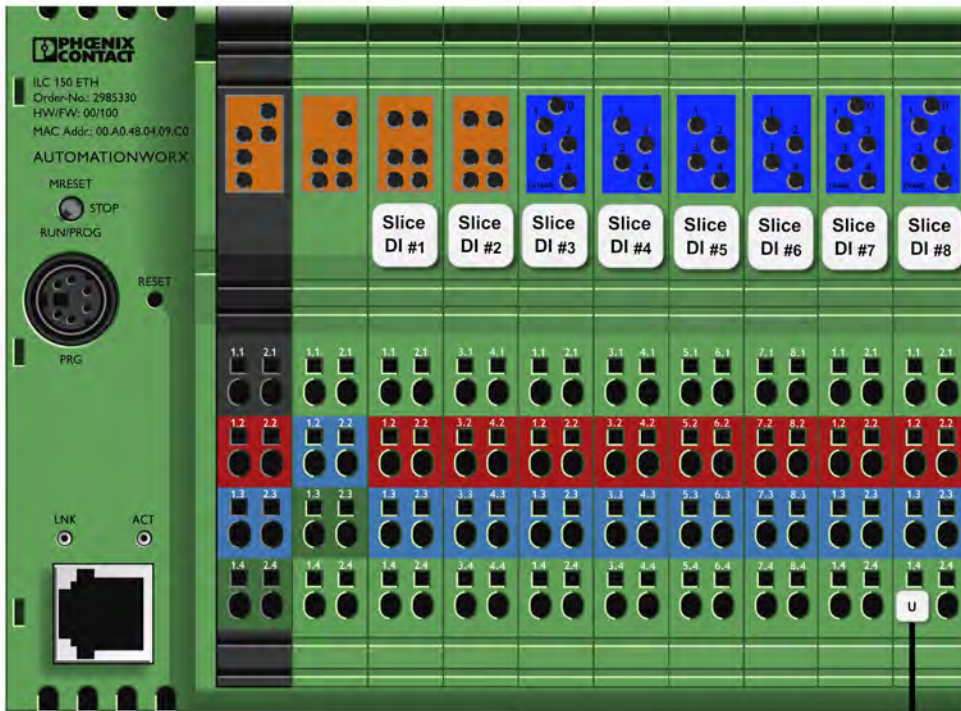

The User Fault Circuit #U is an additional fault circuit provided to the dryer operator for additional equipment monitoring. For example, the dryer operator has a custom unload system that needs to be running in order for the dryer to keep running. The operator can interlock the unload system with the user fault circuit. 24vdc needs to be present under normal operating conditions. An open circuit results in a shutdown.



Factory Jumper Installed in the power box

Title: Tower Dryer User Fault	
Author: SUKUP MFG CO - MRK	
Date: 8/15	
Revision: 6/7/2017 - DWS (1)	108.14

Tower Dryer Motor Overload Circuit #49

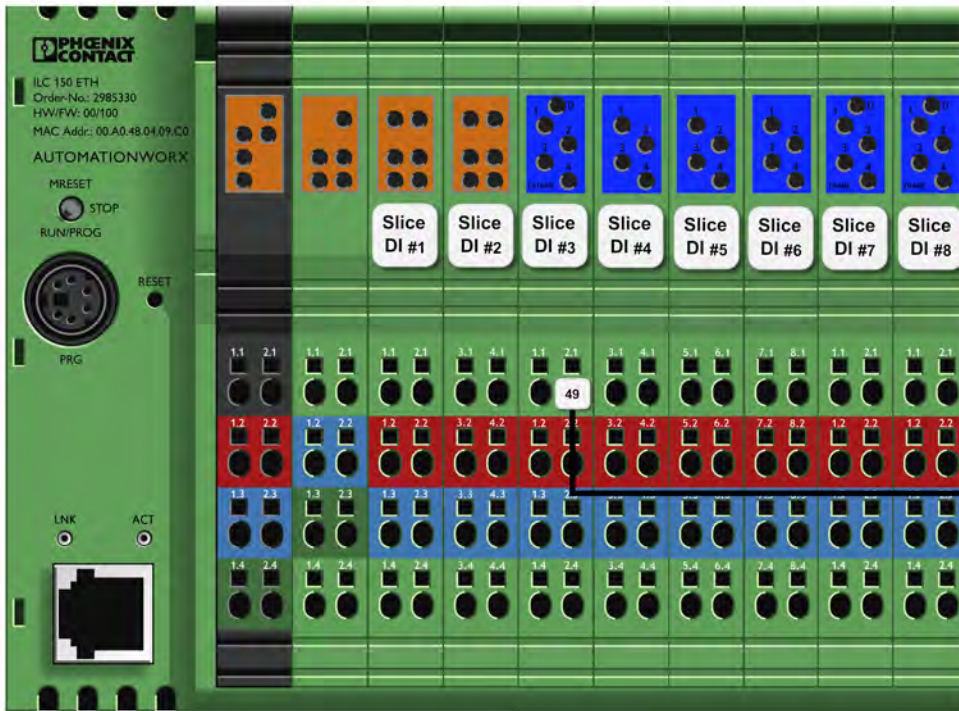

Motor Overload Circuit

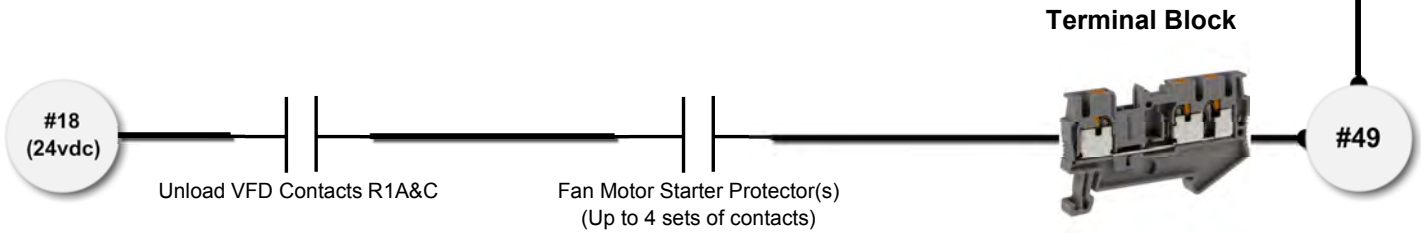

The Motor Overload circuit is a series circuit that starts with 24vdc being applied to Terminal R1C in the Unload VFD. Coming out of R1A, the signal then travels to the fan starter protector's auxiliary contact. As long as the VFD and the Fan Starter(s) are all in normal operation, the 24vdc will return to the PLC as wire #49.

Title: Tower DRYER: Motor Overload	
Author: SUKUP MFG CO - MRK	
Date: 8/15	
Revision: 6/7/2017 - DWS (1)	108.15

Tower Dryer Stall Fault

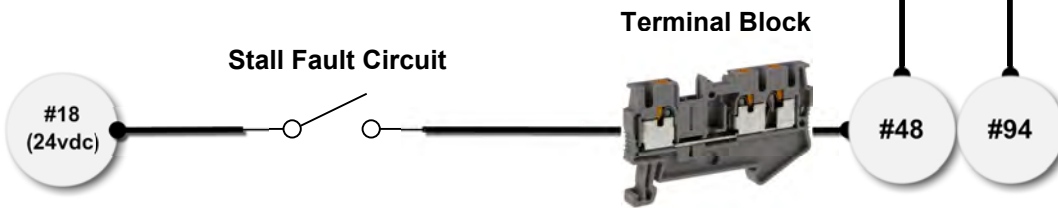
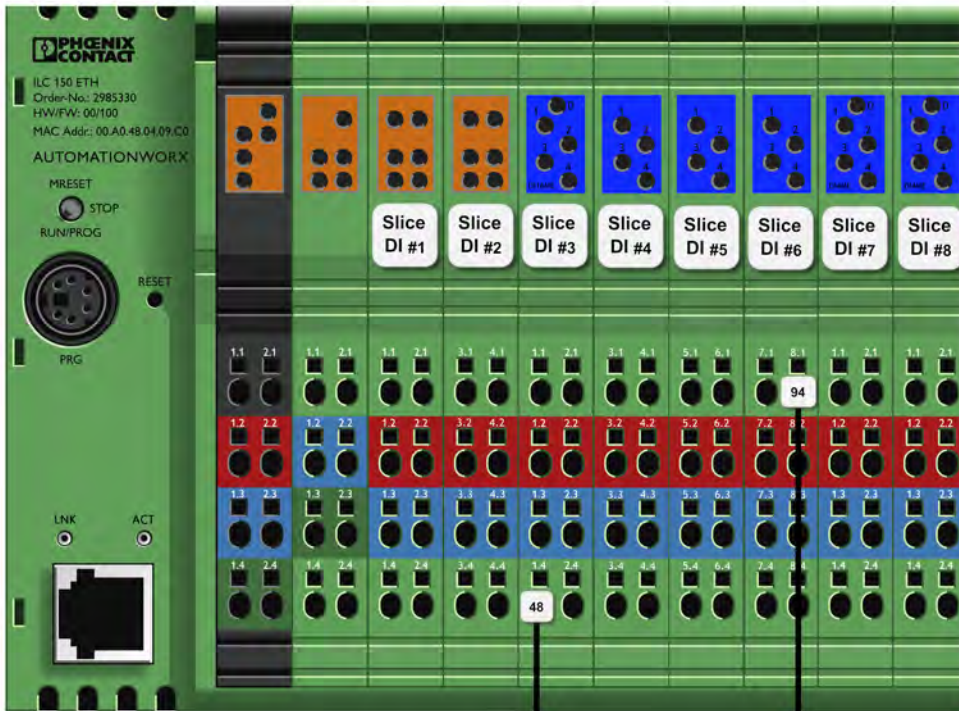

The Stall Fault occurs when the fan(s) and heater(s) have been running for more that 20 minutes without energizing the unload motor (#94). The stall fault timer is displayed on-screen during operation.

Title: Tower DRYER: Stall Fault	
Author: SUKUP MFG CO - MRK	
Date: 8/15	
Revision: 6/7/2017 - DWS (1)	108.16

Column and Plenum RTD Transmitters

Plenum > 275°F

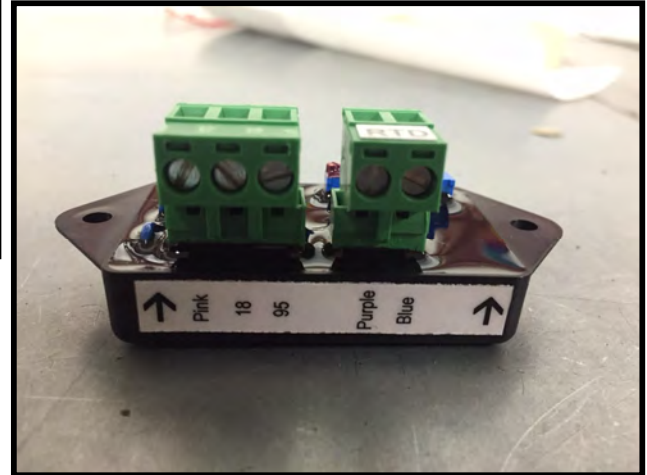
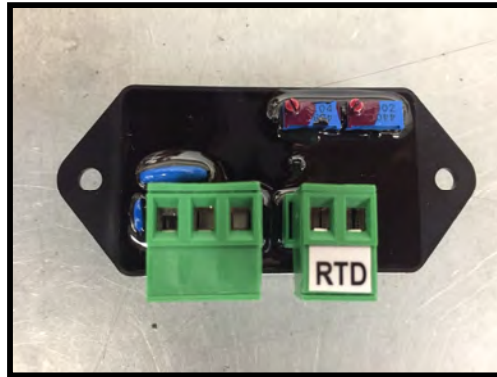

**Pink - DC voltage Reference to PLC
#70-Column
#71-Plenum**

**Wire #18 - 24vdc Power
Wire #95 - dc common (-)**

**Purple - Resistance from RTD
Blue - Resistance from RTD**



The Plenum > 275°F fault is a software shutdown that occurs when the Plenum RTD transmitter sends a reference voltage back to the PLC that indicates an average plenum temperature above 275°F. Typically, another fault device would trip out first, such as the Plenum OT device (#39) or any one of the Column OT devices (#80-#85). If you are experiencing this fault frequently, it's probably an issue with the Plenum RTD, the Plenum RTD transmitter, or a wiring problem.

Title: Tower DRYER: Column and Plenum RTD Transmitter

Author: SUKUP MFG CO - MRK

Date: 03/15

Sheet: 108.17

Revision:

Tower Dryer Digital Outputs

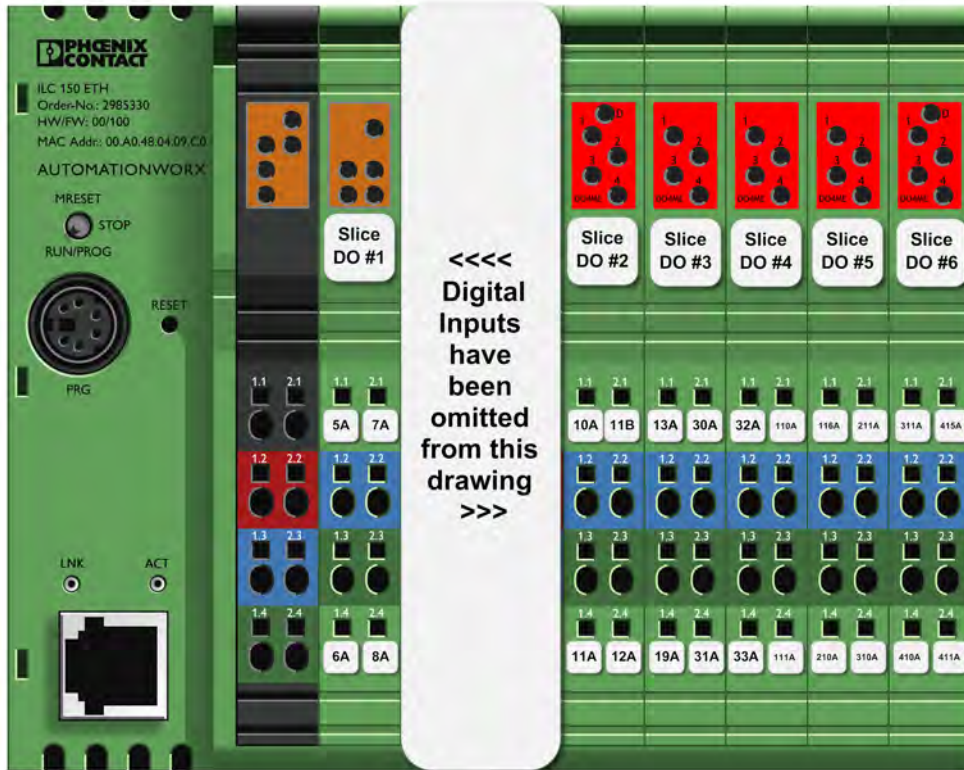

See PLC Relay Wiring for all wiring terminations. Sheets: 112.1 -- 112.4

Title: Tower Dryer Digital Outputs	
Author: SUKUP MFG CO - MRK	
Date: 10/15	Sheet: 109.1
Revision:	

Tower PLC Analog Inputs

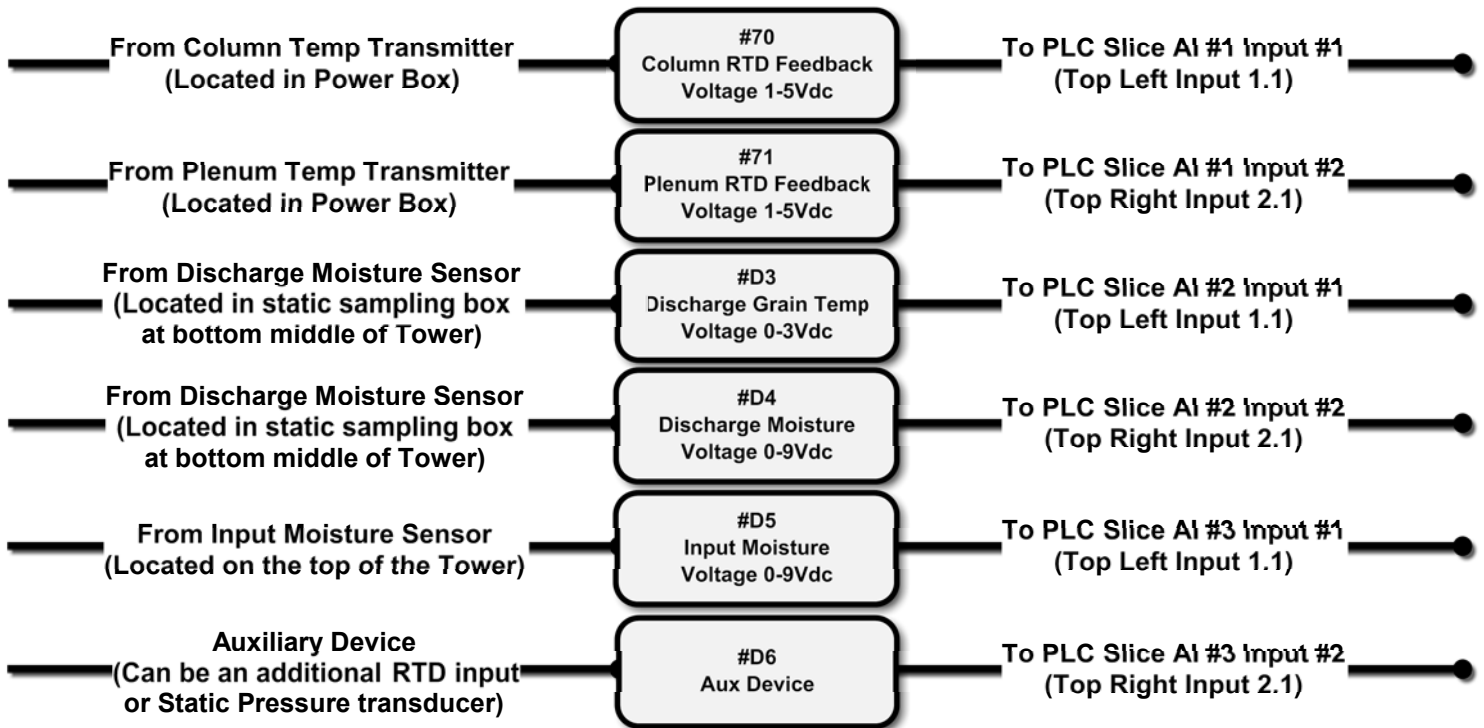

Title: Tower Dryer: Analog Inputs	
Author: SUKUP MFG CO - MRK	
Date: 10/15	Sheet: 110.1
Revision:	

Tower PLC Analog Outputs

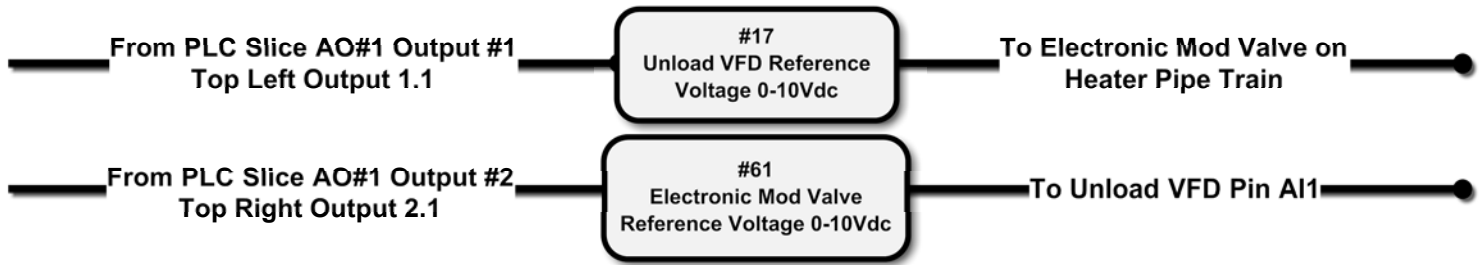

Title: Tower Dryer: Analog Outputs

Author: SUKUP MFG CO - MRK

Date: 10/15

Sheet: 111.1

Revision:

Tower Dryer PLC Relay Wiring

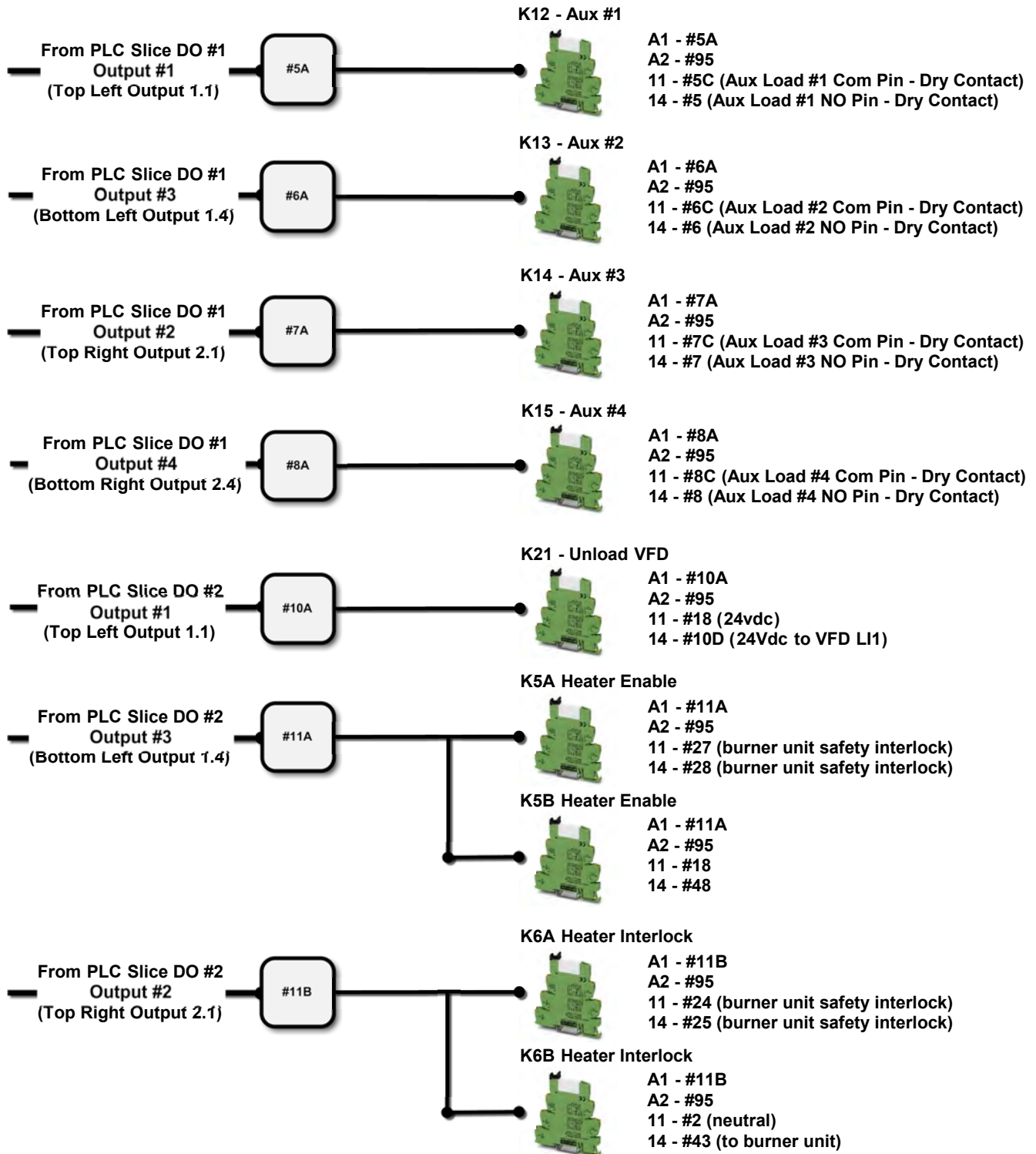

Title: Tower DRYER: PLC Relay Wiring	
Author: SUKUP MFG CO - MRK	
Date: 10/15	Sheet: 112.1
Revision:	

Tower Dryer PLC Relay Wiring

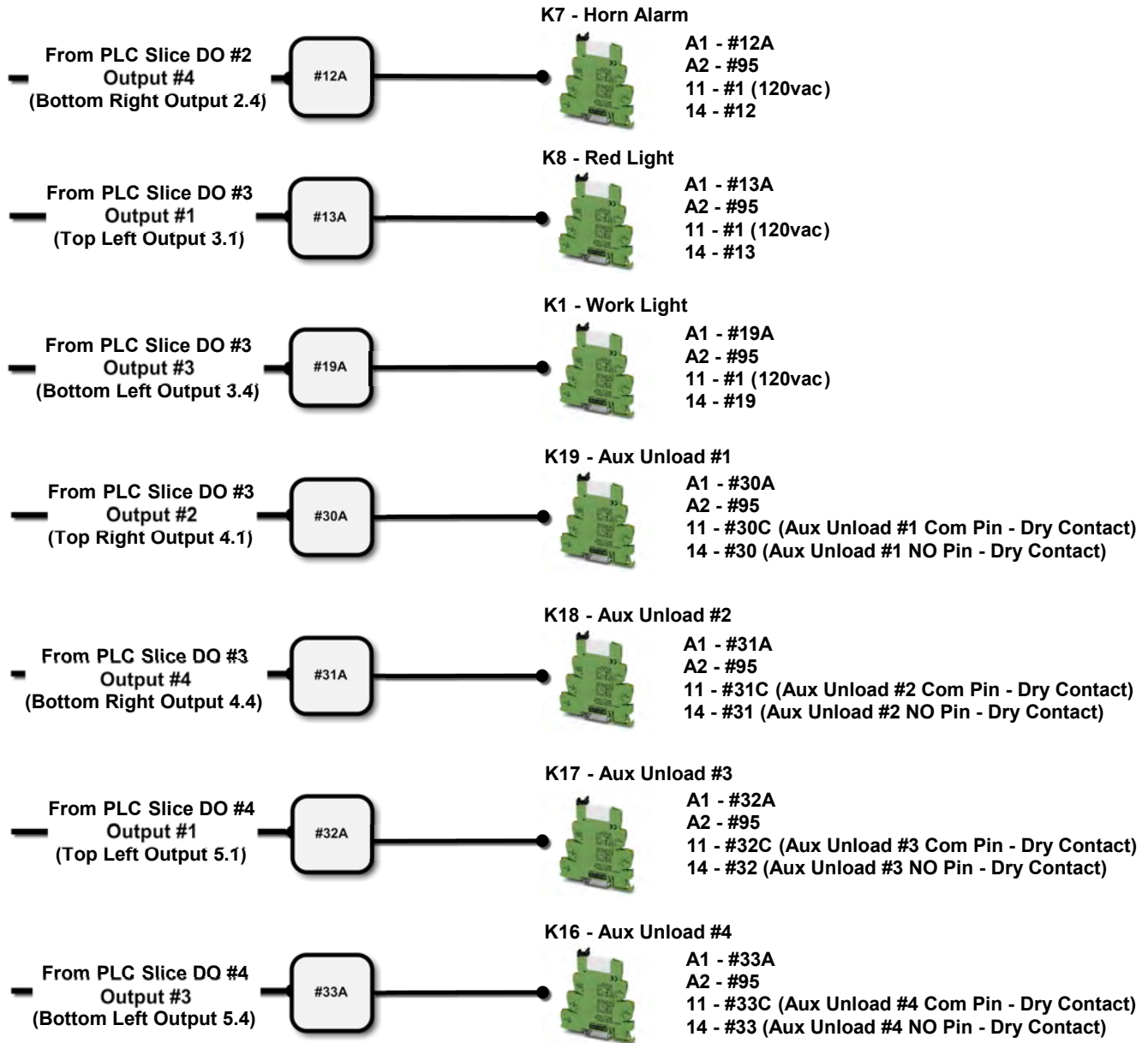

Title: Tower DRYER: PLC Relay Wiring Page 2	
Author: SUKUP MFG CO - MRK	
Date: 10/15	Sheet: 112.2
Revision:	

Tower Dryer PLC Relay Wiring

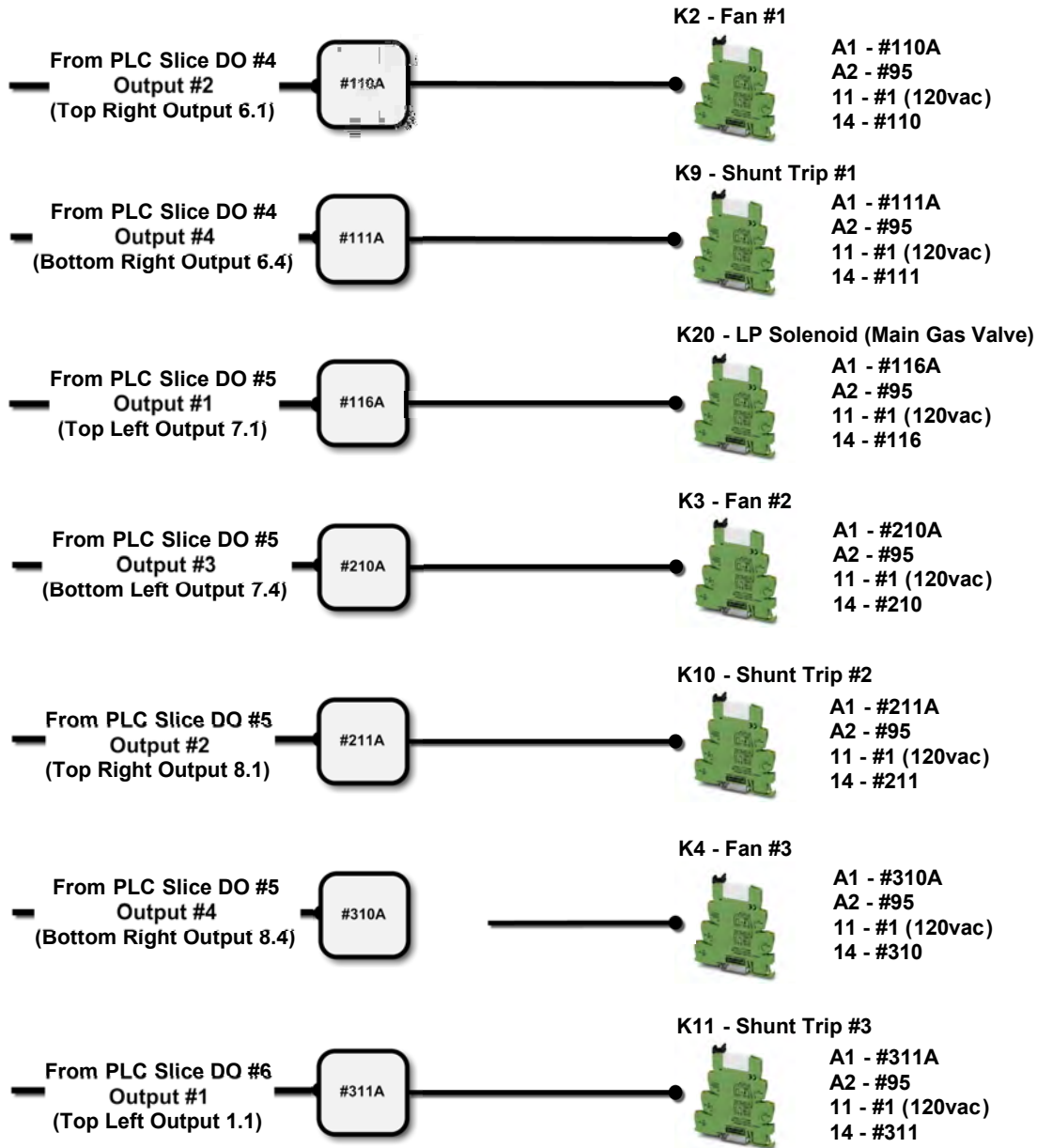

Title: Tower DRYER: PLC Relay Wiring Page 3	
Author: SUKUP MFG CO - MRK	
Date: 10/15	Sheet: 112.3
Revision:	

Tower Dryer PLC Relay Wiring

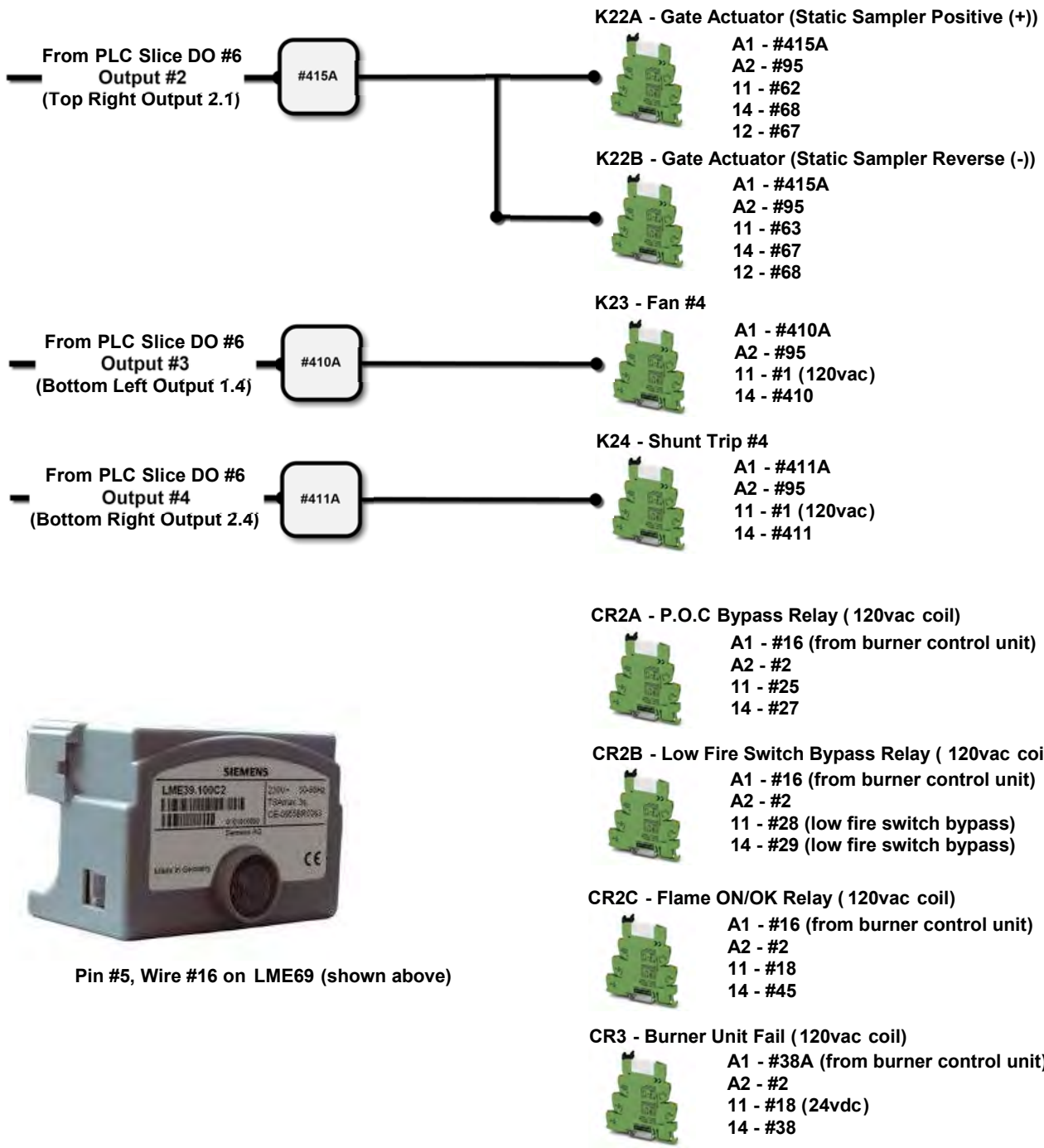

Pin #5, Wire #16 on LME69 (shown above)

Title: Tower DRYER: PLC Relay Wiring Page 4	
Author: SUKUP MFG CO - MRK	
Date: 10/15	Sheet: 112.4
Revision: 8/20/2020 - DWS (1)	



Tower Dryer

QuadraTouch Pro Dryer Control System

Appendices

TABLE OF CONTENTS

Appendix A – Specifications	
Specifications Tables	A-2
Unload Rates	A-3
Appendix B – Electrical Requirements	
Appendix C – Drying Rate Tables	
Appendix D – Ground Rod Requirements	
Appendix E – Setting Unload System	
Appendix F – Adjusting Grain Flow Tube	
Appendix G – Altistart 22 Soft Start	
Programming ATS22 Soft Start	G-2
Troubleshooting	G-5
Appendix H – Altivar Variable Frequency Drive	
Programming ATV 320	H-2
VFD Starter Protector Settings	H-3
Troubleshooting ATV 320	H-4
Appendix I – Burner Control Unit LME 69	
Enabling Diagnostics	I-2
Reading Error Codes	I-3
Appendix J – Optional Features	
Creating & Managing MySukup.com Account	J-2
Auxiliary Motor Control Wiring	J-6

Appendix A

Specifications

**Specifications Tables
Unload Rates**

<u>DATE</u>	<u>REVISION</u>	<u>PAGE</u>
12/28/2022	– Added specifications for Model U1512 dryer-----	A-2

Specifications

Bushels per hour estimates in table below are based on wet No. 2 shelled yellow corn at listed moisture content and are based on drying principles, field results and/or computer simulation at 50° F ambient temperature and 60% humidity at 220° F average plenum temperature.

Factors such as grain variety, maturity levels, grain cleanliness, weather conditions and operation/management can affect performance of tower dryer. Results may vary. This information is calculated and is not a guarantee of product or performance. These specifications should only be used as estimates and not as a warranty, express or implied, of how a particular Sukup unit will perform under your operating conditions. Because products are continually improved, changes may have occurred that are not reflected in these specifications.

	U1512	U1812	U2012	U2412	U2712	U3018	U3518	U4018	U4718	U5024	U6024	U7024	U10030
Bu/hr 20-15% corn	1,500	1,800	2,000	2,400	2,700	3,000	3,500	4,000	4,700	5,000	6,000	7,000	10,000
Bu/hr 25-15% corn	900	1,080	1,200	1,440	1,620	1,800	2,100	2,400	2,820	3,000	3,600	4,200	6,000
Heat holding bushels	915	1,113	1,275	1,521	1,691	1,925	2,208	2,642	2,941	3,469	4,026	4,436	6,266
Cool holding bushels	305	400	434	481	505	642	812	831	1,136	1,238	1,295	1,499	2,117
Total holding bushels	1,689	1,982	2,178	2,471	2,671	3,543	3,996	4,449	5,053	6,336	6,950	7,564	10,684
Drying airflow (CFM)	77,800	85,600	94,600	110,300	117,500	148,200	174,300	206,400	226,200	275,100	296,100	343,500	495,000
Burner cap. (BTU x1000)	16,805	18,490	20,434	23,825	27,000	32,011	37,649	44,582	48,859	59,422	63,958	74,196	106,000
Avg. Heat (BTU x1000)	9,663	10,632	11,749	13,699	14,600	18,406	21,648	25,635	28,094	34,167	36,776	42,663	63,500
Blower hp	75	75	100	100	125	(3) 50	(3) 60	(3) 75	(3) 75	(3) 100	(3) 100	(3) 125	(4) 125
AC drive metering hp	1-1/2	1-1/2	1-1/2	1-1/2	1-1/2	2	2	2	2	3	3	3	7.5
Grain column	12.75"	12.75"	12.75"	12.75"	12.75"	12.75"	12.75"	12.75"	12.75"	12.75"	12.75"	12.75"	12.75"
Tower diameter	12'	12'	12'	12'	12"	18'	18'	18'	18'	24'	24'	24'	30'
Overall height	58.6'	69'	76'	86'	93'	76'	86'	96'	109'	100'	110'	120'	127'
Full load amp. (230v/460v)	223/114	223/114	290/147	290/147	NA/176	390/196	462/233	566/285	566/285	743/374	743/374	NA/455	NA/692

Unload Rates

Tables below show approximate unload rates for Sukup Tower Dryers. They are approximate and can vary due to flow gate and paddle arm settings, varieties of grain, and amount of fines. For an accurate rate, an actual flow test should be done on site.

12' Tower Dryer										
Speed (%)	10	20	30	40	50	60	70	80	90	100
RPM	0.21	0.42	0.63	0.84	1.04	1.25	1.46	1.67	1.88	2.09
Freq. (Hz)	6	12	18	24	30	36	42	48	54	60
BU/HR*	300	600	900	1200	1500	1800	2100	2400	2700	3000

18' Tower Dryer										
Speed (%)	10	20	30	40	50	60	70	80	90	100
RPM	0.17	0.35	0.52	0.7	0.87	1.05	1.22	1.4	1.58	1.74
Freq. (Hz)	6	12	18	24	30	36	42	48	54	60
BU/HR*	550	1100	1650	2200	2750	3300	3850	4400	4950	5500

24' Tower Dryer										
Speed (%)	10	20	30	40	50	60	70	80	90	100
RPM	0.17	0.35	0.52	0.7	0.87	1.05	1.22	1.4	1.57	1.74
Freq. (Hz)	6	12	18	24	30	36	42	48	54	60
BU/HR*	800	1600	2400	2800	4000	4800	5600	6400	7200	8000

30' Tower Dryer										
Speed (%)	10	20	30	40	50	60	70	80	90	100
RPM	0.27	0.54	0.81	1.08	1.35	1.61	1.88	2.15	2.42	2.69
Freq. (Hz)	6	12	18	24	30	36	42	48	54	60
BU/HR*	1500	3000	4500	6000	7500	9000	10500	12000	13500	15000

Appendix B

Electrical Requirements

Single-fan Dryers

Three-fan Dryers

Electrical Requirements

IMPORTANT: Grain Dryer power box contains a molded case disconnect switch for incoming power. **IT IS NOT A CIRCUIT BREAKER!** A service-rated, fused disconnect needs to be installed ahead of grain dryer power distribution box. This disconnect is not included with dryer and should be installed by a qualified electrician. **Grain dryer should be only device connected to this disconnect.**

NOTE: Incoming Current (Amps) shows the total current required (with Service Factor) to **continuously** operate a dryer's fan motor(s), unload motor and control circuitry. **During fan startup**, the Soft Start will limit fan motor(s) amp draw to 350% of nameplate FLA. If this 350% inrush current cannot be provided by main transformer, motor may not get up to speed before a fault condition occurs, especially in cold weather. Changing Soft Start settings and timing may be required to start fan. Consult Sukup dealer before making any settings adjustments. If motors still will not start after adjustments, a larger transformer or a different starting method, variable frequency drive (VFD) may be needed.

The following tables provide information for the electrician wiring the grain dryer. It is recommended that the local power company be contacted to have a representative inspect installation to ensure wiring is compatible with their system, and that sufficient power is supplied to dryer.

Standard electrical safety practices and codes should be used. Refer to the National Electrical Code (NEC) Handbook by the National Fire Protection Association (NFPA).

All electrical work should be completed by a qualified electrician.

Appendix B

Electrical Requirements by Panel # (3-Phase)																		
Panel #	Start Method	Voltage	Fan(s) HP	Fan Motor #1	Fan Motor #2	Fan Motor #3	Fan Motor #4	Load Motor #	Unload Motor #	Fan 1	Fan 2	Fan 3	Fan 4	VFD Setting (A)	4 Aux Amps	Panel Amps	Main Switch Size (A)	Total Max Amps
U10995	SS	230	50	H7210	--	--	--	H1445	H1445	134.6	--	--	--	4.4	0	139	250	139
U10997	SS	460	50	H7210	--	--	--	H1445	H1445	66.7	--	--	--	2.3	0	69	250	69
U12992	SS	230	60	H7260	--	--	--	H1445	H1445	159.9	--	--	--	4.4	0	164	250	164
U12993	LS	460	75	H7505	--	--	--	H1445	H1445	98.3	--	--	--	2.3	0	101	250	101
U12994	SS	380	125	H7511	--	--	--	L3080	L3080	153.5	--	--	--	--	0	154	250	154
U12995	SS	230	100	H7510	--	--	--	H1445	H1445	258.8	--	--	--	4.4	0	263	400	263
U129959	SS	208	100	H7510	--	--	--	H1445	H1445	286.1	--	--	--	4.4	0	291	400	291
U12996	SS	460	100	H7510	--	--	--	H1445	H1445	129.4	--	--	--	2.3	0	132	250	132
U129961	VFD	460	100	H7510	--	--	--	H1445	H1445	129.4	--	--	--	2.3	0	132	250	132
U129962	SS	380	100	H7530	--	--	--	H1445	H1445	115.0	--	--	--	2.3	0	117	250	117
U129991	SS	460	125	H7511	--	--	--	H1445	H1445	171.9	--	--	--	4.0	0	176	250	176
U12997	SS	460	60	H7260	--	--	--	H1445	H1445	79.9	--	--	--	2.3	0	82	250	82
U12998	SS	460	75	H7505	--	--	--	H1445	H1445	98.3	--	--	--	2.3	0	101	250	101
U12999	SS	575	100	H7509	--	--	--	H1445	H1445	104.1	--	--	--	2.3	0	106	250	106
U129931	SS	230	40	H7200	H7200	H7200	--	H2040	H2040	105.8	105.8	105.8	--	6.0	0	323	400	323
U129951	SS	460	40	H7200	H7200	H7200	--	H2040	H2040	52.9	52.9	52.9	--	3.0	0	162	250	162

Information is organized by panel number. Panel number and other important information can be found on white sticker inside main power box.

Appendix B

Electrical Requirements by Panel # (3-Phase) - continued																		
Panel #	Start Method	Voltage	Fan(s) HP	Fan Motor #1	Fan Motor #2	Fan Motor #3	Fan Motor #4	Load Motor #	Unload Motor #	Fan 1	Fan 2	Fan 3	Fan 4	VFD Setting (A)	4 Aux Amps	Panel Amps	Main Switch Size (A)	Total Max Amps
U18994	SS	460	60	H7260	H7260	H7260	--	H2040	H2040	79.9	79.9	79.9	--	3.0	0	243	250	243
U18995	SS	230	75	H7505	--	--	--	H1445	H1445	196.7	--	--	--	2.3	0	199	250	199
U18996	SS	460	75	H7505	H7505	H7505	--	H2040	H2040	98.3	98.3	98.3	--	3.0	0	298	400	298
U189951	SS	380	75	H7505	--	--	--	L3077	L3077	95.0	--	--	--	3.0	0	98	250	98
U189981	SS	380	75	H7505	H7505	H7505	--	L3077	L3077	95.0	95.0	95.0	--	--	0	285	400	285
U189982	SS	460	50	H7210	H7210	H7210	--	H2040	H2040	66.7	66.7	66.7	--	3.0	0	203	250	203
U189983	SS	460	60	H7260	H7260	H7260	--	H2040	H2040	79.9	79.9	79.9	--	3.0	0	243	250	243
U189986	SS	380	60	H7270	H7270	H7270	--	H2560	H2560	95.0	95.0	95.0	--	--	0	285	400	285
U189987	SS	575	60	H7262	H7262	H7262	--	H1445	H1445	60.3	60.3	60.3	--	2.3	0	183	250	183
U189988	SS	380	60	L3075	L3075	L3075	--	H1445	H1445	69.0	69.0	69.0	--	2.3	0	209	250	209
U189991	SS	230	50	H7210	H7210	H7210	--	H2040	H2040	134.6	134.6	134.6	--	6.0	0	410	600	410
U189992	SS	575	75	H7505	H7505	H7505	--	H2040	H2040	95.5	95.5	95.5	--	6.0	0	292	400	292
U189993	LS	230	75	H7505				H1445	H1445	115.0	115.0	115.0	--	--	0	197	250	197
U189994	SS	380	100	H7510	H7510	H7510	--	L3077	L3077	115.0	115.0	115.0	--	--	0	345	400	345
U189997	SS	230	60	H7260	H7260	H7260	--	H2040	H2040	159.9	159.9	159.9	--	6.0	0	486	600	486
U189998	SS	230	75	H7505	H7505	H7505	--	H2040	H2040	196.7	196.7	196.7	--	6.0	0	596	600	596
U24995	SS	460	100	H7510	H7510	H7510	--	H2980	H2980	129.4	129.4	129.4	--	4.0	0	392	400	392
U24997	SS	380	125	H7511	H7511	H7511	--	L3081	L3081	153.5	153.5	153.5	--	4.0	0	465	600	465
U24998	SS	460	125	H7511	H7511	H7511	--	H2980	H2980	171.9	171.9	171.9	--	4.0	0	520	600	520
U24999	SS	460	125	H7511	H7511	H7511	H7511	H2980	H2980	171.9	171.9	171.9	171.9	4.0	0	692	800	692

Information is organized by panel number. Panel number and other important information can be found on white sticker inside main power box.

Appendix C

Drying Rate Tables

<u>DATE</u>	<u>REVISION</u>
12/28/2022	– Added specifications for Model U1512 dryer-----C-2 & C-3

Drying Rate Tables

Following are tables showing suggested unloading (drying) rates based on plenum temperatures and amount of moisture to be removed. **Example:** On a U2412 dryer, to remove 5 points of moisture with a plenum temperature of 170 degrees, unload rate should be set to 59%. Use “Manual Mode” on QuadraTouch Pro controller and adjust Unload Speed Setpoint to 59%.

Numbers in charts are a good **starting point** when running in Manual. Final running speed may differ from charts as user may adjust speed as dryer runs. Distance between bottom of flow gate and unload table should be 5-1/2 inches.

These suggested rates are not guaranteed, nor should they be used as a capacity rating. Many factors such as flow gate setting, grain hybrid, fines, weather conditions, etc. may affect drying rate.

Setting Unload Rotor Speed

1. Using your grain input moisture and desired plenum temperature, use appropriate table on following pages to calculate approximate unload rate. Start dryer unload.
2. See table below for the approximate time it will take to turn the dryer over one complete time.
3. Calibrate discharge moisture sensor. See Operation section.
4. After the time from table below has expired, adjust unload rotor speed accordingly. If grain moisture is too wet, decrease speed, if too dry, increase speed. Typically it is only necessary to adjust by a few percentage points at a time. Allow at least 20-30 minutes between changes.
5. Once moisture sensor has been calibrated and you are seeing your desired output moisture on the screen, let the dryer run for at least half the amount of time initially calculated to turn the dryer completely. Outgoing grain moisture should be within .5% of desired moisture content before switching unload from Manual to Automatic.

MINUTES TO TURN OVER DRYER PER UNLOAD RATE %										
MODEL	10	20	30	40	50	60	70	80	90	100
U1512	338	169	113	84	68	56	48	42	38	34
U1812	396	198	132	99	79	66	57	50	44	40
U2012	436	218	145	109	87	73	62	54	48	44
U2412	493	247	165	124	99	82	71	62	55	49
U2712	439	220	146	110	88	73	63	55	49	44
U3018	387	193	129	97	77	64	55	48	43	39
U3518	436	218	145	109	87	73	62	54	48	44
U4018	485	243	162	121	97	81	69	61	54	49
U4718	551	276	184	138	110	92	79	69	61	55
U5024	475	238	158	136	95	79	68	59	53	48
U6024	386	187	126	95	75	63	54	47	42	38
U7024	567	284	189	162	113	95	81	71	63	57
U10030	335	168	112	84	67	56	48	42	37	34

MODEL U1512 Unload Rate % at Listed Moisture Removal			
PLENUM TEMP (F)	18 – 15 %	20 – 15 %	25 – 15 %
140	37	32	19
150	42	36	22
160	47	40	24
170	51	44	27
180	56	48	29
190	61	53	32
200	66	57	34
210	71	61	37
220	75	65	39

MODEL U1812 Unload Rate % at Listed Moisture Removal			
PLENUM TEMP (F)	18 – 15 %	20 – 15 %	25 – 15 %
140	37	32	19
150	42	36	22
160	47	40	24
170	51	44	27
180	56	48	29
190	61	53	32
200	66	57	34
210	71	61	37
220	75	65	39

MODEL U2012 Unload Rate % at Listed Moisture Removal			
PLENUM TEMP (F)	18 – 15 %	20 – 15 %	25 – 15 %
140	41	35	21
150	46	40	24
160	52	44	27
170	57	49	29
180	62	54	32
190	68	58	35
200	73	63	38
210	78	67	40
220	84	72	43

MODEL U2412 Unload Rate % at Listed Moisture Removal			
PLENUM TEMP (F)	18 – 15 %	20 – 15 %	25 – 15 %
140	49	43	26
150	56	48	29
160	62	54	32
170	69	59	36
180	75	65	39
190	82	70	42
200	88	76	46
210	95	81	49
220	99	87	52

MODEL U2712 Unload Rate % at Listed Moisture Removal			
PLENUM TEMP (F)	18 – 15 %	20 – 15 %	25 – 15 %
140	62	43	26
150	71	49	29
160	80	55	33
170	89	61	37
180	98	67	40
190	100	73	44
200	100	79	48
210	100	85	51
220	100	92	55

MODEL U3018 Unload Rate % at Listed Moisture Removal			
PLENUM TEMP (F)	18 – 15 %	20 – 15 %	25 – 15 %
140	32	27	16
150	36	31	19
160	40	35	21
170	44	38	23
180	48	42	25
190	53	45	27
200	57	49	29
210	61	52	31
220	65	56	34

MODEL U3518 Unload Rate % at Listed Moisture Removal			
PLENUM TEMP (F)	18 – 15 %	20 – 15 %	25 – 15 %
140	37	32	19
150	42	36	22
160	47	40	24
170	51	44	27
180	56	48	29
190	61	53	32
200	66	57	34
210	71	61	37
220	75	65	39

MODEL U4018 Unload Rate % at Listed Moisture Removal			
PLENUM TEMP (F)	18 – 15 %	20 – 15 %	25 – 15 %
140	42	36	22
150	48	41	25
160	53	46	27
170	59	50	30
180	64	55	33
190	69	60	36
200	75	65	39
210	80	69	42
220	86	74	44

MODEL U4718 Unload Rate % at Listed Moisture Removal			
PLENUM TEMP (F)	18 – 15 %	20 – 15 %	25 – 15 %
140	49	43	26
150	56	48	29
160	62	54	32
170	69	59	36
180	75	65	39
190	82	70	42
200	88	76	46
210	95	81	49
220	99	87	52

MODEL U5024 Unload Rate % at Listed Moisture Removal			
PLENUM TEMP (F)	18 – 15 %	20 – 15 %	25 – 15 %
140	36	31	19
150	40	35	21
160	45	39	23
170	50	43	26
180	54	47	28
190	59	51	31
200	64	55	33
210	68	59	35
220	73	63	38

MODEL U6024 Unload Rate % at Listed Moisture Removal			
PLENUM TEMP (F)	18 – 15 %	20 – 15 %	25 – 15 %
140	43	37	22
150	48	42	25
160	54	46	28
170	59	51	31
180	65	56	34
190	70	61	36
200	76	65	39
210	81	70	42
220	87	75	45

MODEL U7024 Unload Rate % at Listed Moisture Removal			
PLENUM TEMP (F)	18 – 15 %	20 – 15 %	25 – 15 %
140	50	43	26
150	57	49	29
160	63	54	33
170	70	60	36
180	76	66	39
190	83	71	43
200	89	77	46
210	96	82	49
220	99	88	53

MODEL U10030 Unload Rate % at Listed Moisture Removal			
PLENUM TEMP (F)	18 – 15 %	20 – 15 %	25 – 15 %
140	25	21	13
150	31	27	16
160	38	32	19
170	44	38	23
180	51	43	26
190	57	49	29
200	64	55	33
210	70	60	36
220	77	66	39

Appendix D

Ground Rod Requirements

<u>DATE</u>	<u>REVISION</u>
12/28/2022 – Updated photo of sample box	-----D-2

Ground Rod Requirements

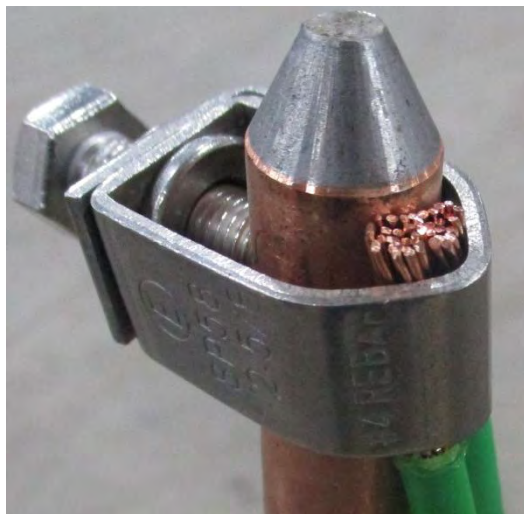

Wires clamped to ground rod

A grounding kit (T18529) is supplied with each dryer. It includes a clamp (J5723), two terminal rings (J3808), and two green grounding wires. Kit can be found in main power box. An 8' long grounding rod (J5722) is also supplied.

Proper grounding will provide added safety in case of any short or lightning strike. Installation of ground rod and ground wire must conform to National Electrical Code Handbook procedures.

Dryer should be grounded at two locations; one at main power box and the other near discharge moisture sensor.



Grounding at main power box

Crimp a terminal ring onto one end of each grounding wire. Attach one wire to back of main power box as shown at left.

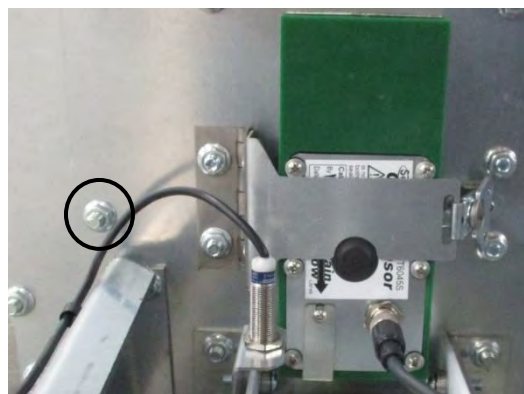

Grounding at sample box

Bolt other grounding wire to static sample box using existing hardware as shown at left.

Pound entire rod into ground within 8 feet of dryer, even if rod must be at an angle. Clamp ends of wires to rod as shown above.



WARNING: Make sure no utilities are buried under ground. Contact with buried electrical wire could result in death or serious injury.

NOTE: Ground rod at power pole will **not** provide sufficient grounding for dryer.

IMPORTANT: Ground rod must be installed to validate dryer warranty.

Appendix E

Setting Unload System

Setting Unload System

This should be done before/during first time dryer is used, and checked yearly.

It is critical that unload system of dryer is set properly so all grain columns will flow at same rate. If a column flows much slower than others, grain will be over-dried. If a column flows much faster than others, grain will be under-dried. Uneven drying is energy-inefficient, reduces dryer capacity, and reduces quality of grain.

To get columns to discharge a consistent amount of grain, first make sure that scraper blades on unload rotor are parallel with grain floor. If scrapers are nearly touching the floor on one side of dryer and are 2" above floor on other side, dryer will discharge grain unevenly. If grain floor is not perfectly level, then rotor shaft and scraper blades will need to be adjusted. Once rotor is parallel to grain floor, flow gates on each column are used to fine-tune discharge rate. **See Fig. 1 for component identification and follow steps 1-7 to set unload system.**

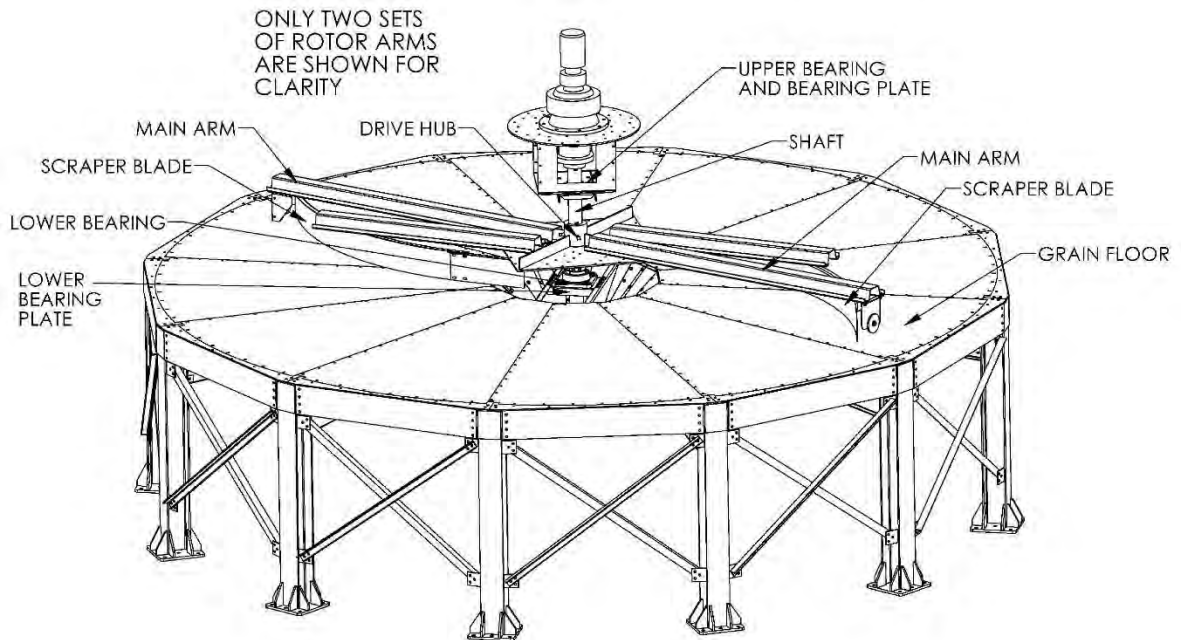

Fig. 1 – Unload system components

1. **Make sure bottom of scraper blades are parallel to grain floor.** Choose one scraper blade and measure distance from bottom of blade to grain floor. See Fig. 2. Run unload rotor and stop it every 90° to check the same measurement. If measurements vary by more than 1/2", adjust angle of rotor and shaft.

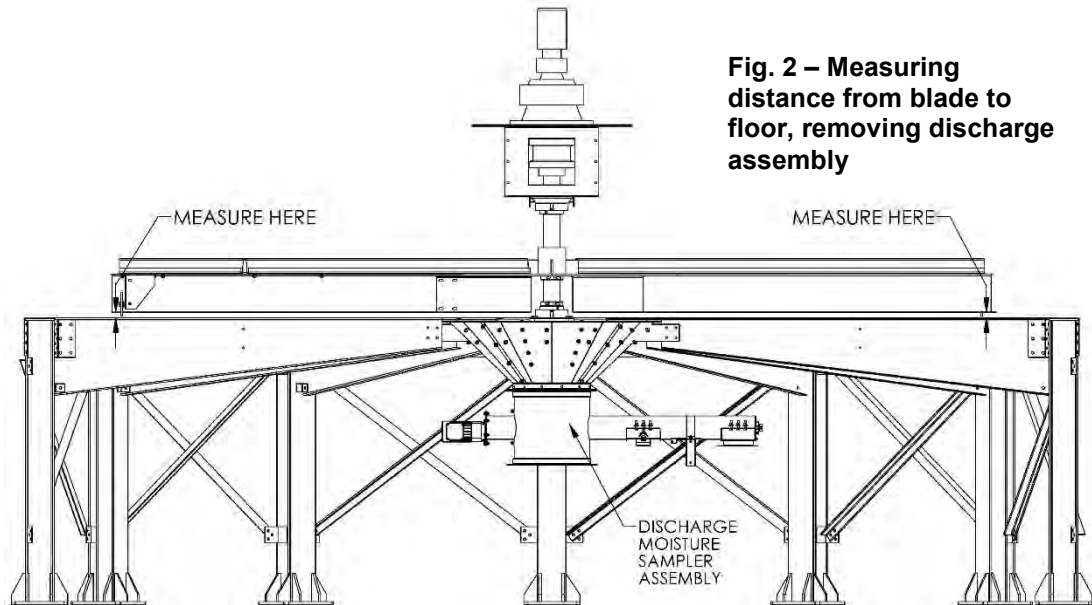

Fig. 2 – Measuring distance from blade to floor, removing discharge assembly

- 2. Adjust rotor/shaft angle to grain floor.** Start by loosening four bolts for upper bearing, but do not remove bolts. Next, remove discharge moisture sampler assembly. See Fig. 2. This will provide access to lower bearing bolts and bottom of rotor shaft. Loosen four bolts on lower bearing and 10 bolts on lower bearing plate, but do not remove bolts. Lower bearing bolts are in slots in one direction and bolts holding bearing plate in are slotted in other direction. See Fig. 3. Using a pry bar from under dryer, push rotor shaft in direction needed to equalize measurements taken in Step 1. **NOTE:** On some tower dryers there may not be slots in lower bearing plate. If necessary, use a grinder to make slots or use slightly smaller bolts for lower bearing. Retighten all bolts once shaft has been adjusted.

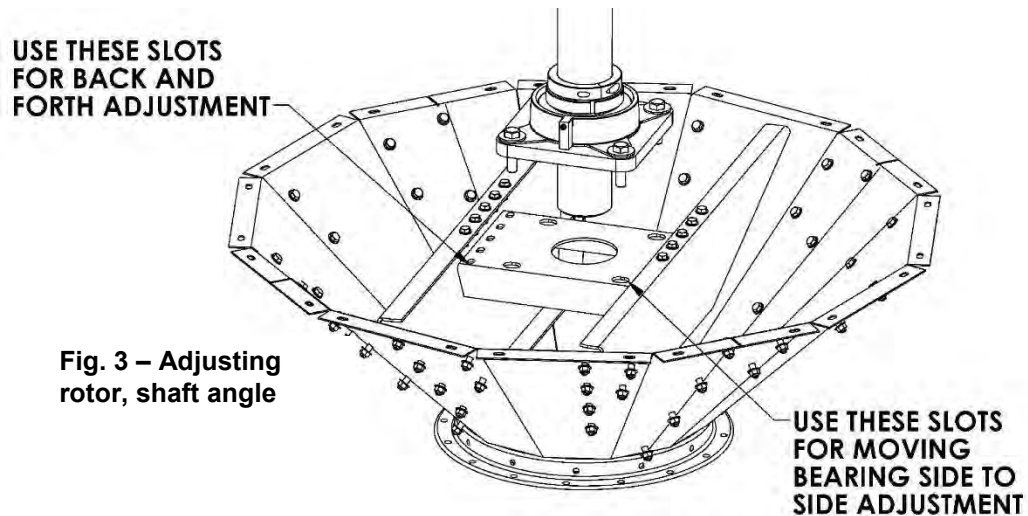

Fig. 3 – Adjusting rotor, shaft angle

- 3. Set height of rotor on shaft.** Scraper blades should be as close to grain floor as possible without touching it. Make sure all washers/spacers are removed between drive hub and main arms. Raise (or lower) drive hub until scraper blades are just higher than highest point of grain floor. To raise rotor, loosen setscrews on drive hub and use a bottle jack between drive hub and lower bearing support plate. See Fig. 4. Two jacks may be needed if hub binds on shaft.

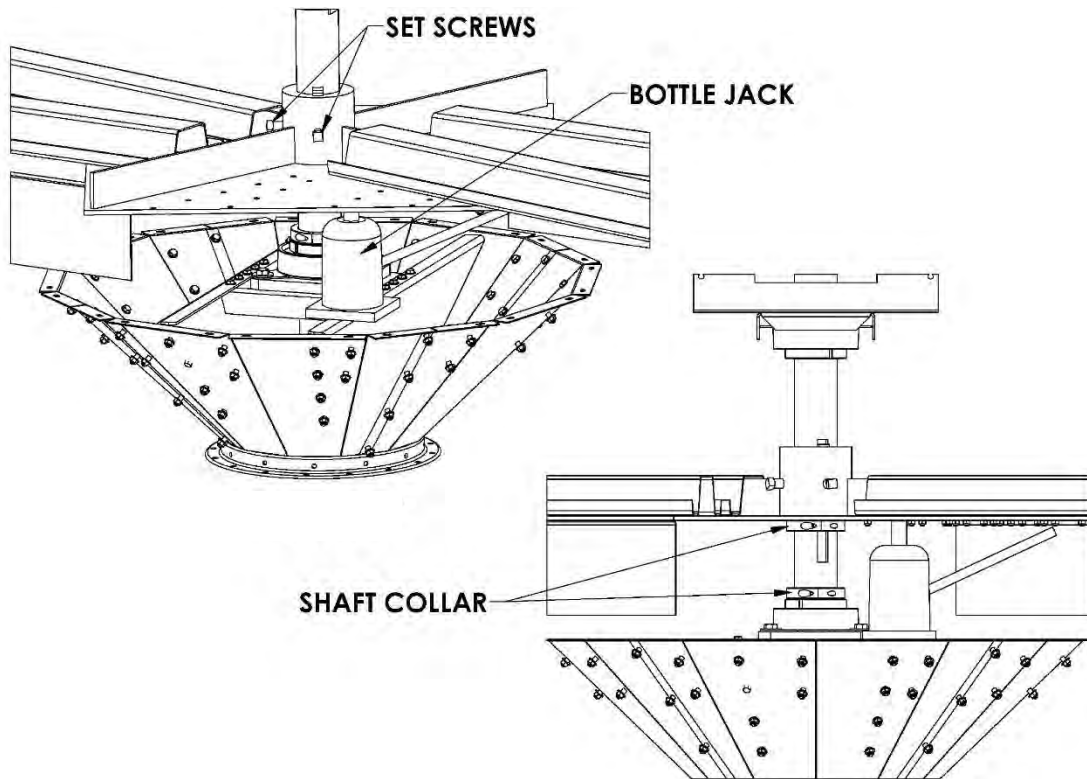

Fig. 4 – Securing rotor height with shaft collars

After drive hub is raised up on shaft, tighten setscrews and position two shaft collars between bottom of drive hub and top of lower bearing as shown in Fig. 4. This keeps shaft and drive hub from slipping down.

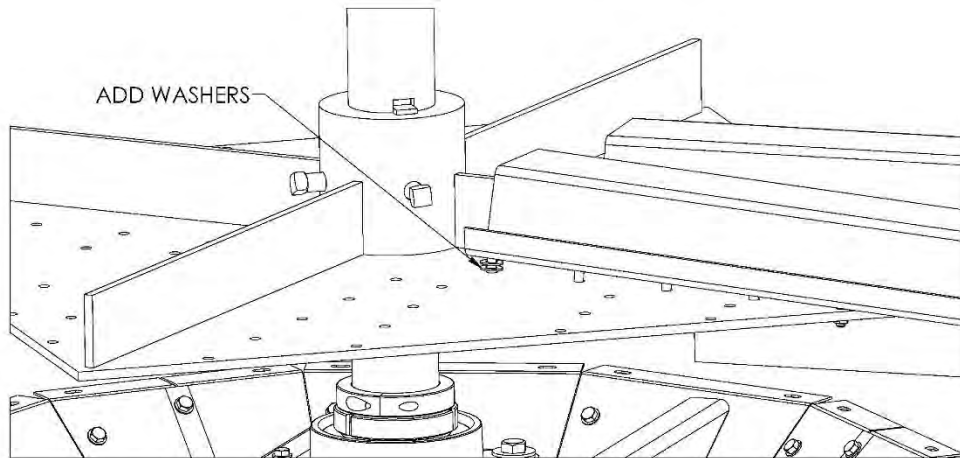

Fig. 5 – Using shims to position scraper blades

4. **Shim main arms so scraper blades are as close to grain floor as possible without touching it.** Use washers as shims between each main arm and drive hub. See Fig. 5. Shim washers should go only on bolts closest to center. If scraper blade needs to be higher on outside, entire drive hub should be jacked up higher. Run rotor a full revolution and make sure scraper blades do not touch grain floor. Adjust white poly wheels so they barely touch grain floor.

5. **Adjust flow gates.** Each column of tower dryer has its own independently adjustable flow gate. Check that each flow gate is set at distance of 5-1/2" from grain floor. **Tip:** Use two blocks of wood 5-1/2" in height as gauges on each side of gate. **NOTE:** When dryer is full of grain, it is easier to raise flow gates than lower them.

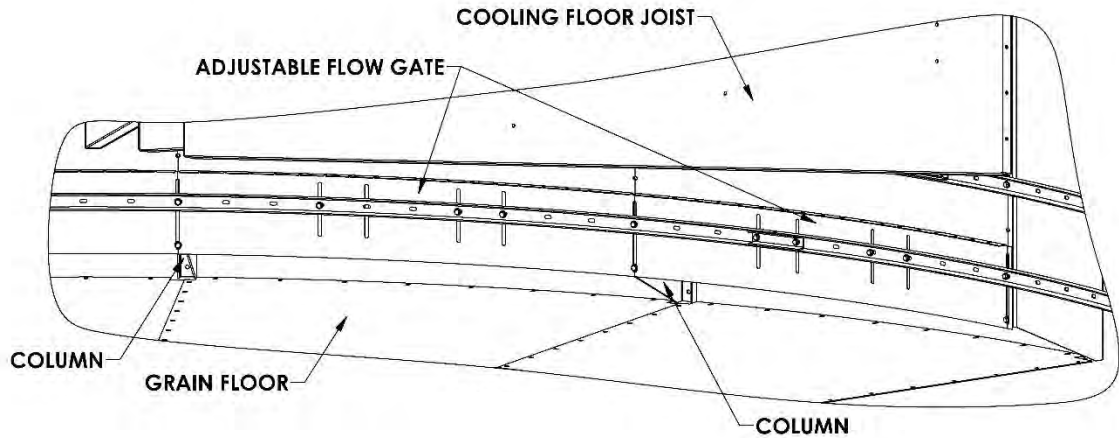

Fig. 6 – Adjusting flow gates

6. **Check grain levels.** Fill dryer with grain and then turn **load** system off. Run **unload** system for 10-20 minutes. Check level of grain in each column. Raising flow gates makes grain flow down columns faster; lowering flow gates makes grain flow down columns slower. Scraper blades should be full of grain to top of scraper, with just a little flowing over, to get maximum capacity. If scrapers are not full of grain, raise flow gates 1/4" to 1/2" on columns with more grain in them. If a lot of grain is flowing over scrapers, lower flow gates 1/4" to 1/2" on columns with less grain in them.
7. **Fine-tune flow rates.** Repeat Step 6 until grain flows are consistent in all columns. **NOTE:** Columns with pass-thru doors into dryer will flow faster than other columns because there is less grain in them. Flow gate settings will likely have to be higher than those for other columns.

Appendix F

Adjusting Grain Flow Tube

Adjusting Grain Flow Tube

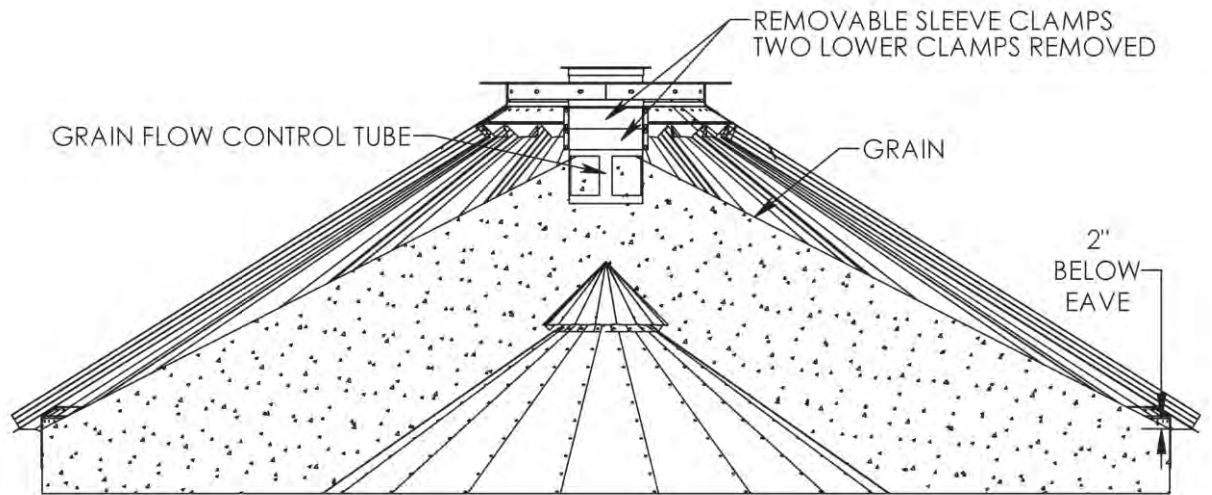

Adjusting grain flow tube

Grain flow control tube near top of dryer is adjustable. See drawing above. Sleeve clamps can be removed or added as needed to ensure grain does not press against roof of dryer. As shown above, grain should be no higher than 2 inches below eave of tower roof.

Appendix G

Altistart 22 Soft Start

Programming ATS22 Soft Start
Motor Full-load Amps
Troubleshooting ATS22

<u>DATE</u>	<u>REVISION</u>	<u>PAGE</u>
12/28/2022	– Updated ATS22 Soft Start programming instructions	G-2 – G-4

Programming ATS22 Soft Start

The following information is needed from motor nameplate before programming.

Motor Voltage: _____ (Step 5)
Motor Horsepower _____
Motor Full Load Amps: _____ (Step 10)

Steps to program ATS22 Soft Start

1. Press the down arrow until **conF (Configuration Menu)** is shown on the screen.
2. Press Enter.
3. Press the up or down arrow until **UIn (Line Voltage)** is shown on the screen.
4. Press Enter.
5. Press up or down arrow until the display shows the line voltage of the dryer. If dryer is 230VAC, set it to 240. If dryer is 380VAC, set it to 400. If dryer is 460VAC, set it to 480. If dryer is 575VAC, set it to 600.
6. Press Enter. Display should blink, indicating that the new value is set into memory.
7. Press Escape.
8. Press the down arrow until **In (Motor Rated Current)** is shown.
9. Press Enter.
10. Press the up or down arrow to find applicable motor current stated on Page G-4 table.
11. Press Enter. Display should blink, indicating that new value is set into memory.
12. Press Escape.
13. Press the down arrow until **LAC (Advanced Mode)** is shown on screen.
14. Press Enter.
15. Press the down or up arrow until **on** is shown on screen.
16. Press Enter. Display should blink, indicating that the new value is set into memory.
17. Press Escape.
18. Press Escape again. Display should show **ConF**.
19. Press the down arrow until **SEt (Settings Menu)** is shown on the screen.
20. Press Enter.
21. Display should show **t90 (Initial voltage)**. If not, press down arrow until it appears on screen.
22. Press Enter.
23. Press the down or up arrow until **50** is displayed on the screen.
24. Press Enter. Display should blink, indicating that new value is set into memory.
25. Press Escape.
26. Press the down arrow until **tLS (Max Start Time)** is shown on the screen.
27. Press Enter.
28. Press the down or up button until **50** is displayed.
29. Press Enter. Display should blink, indicating that the new value is set into memory.
30. Press Escape.
31. Press the down arrow until **ACC (Acceleration time)** is displayed on the screen.
32. Press Enter.
33. Press the down or up arrow until **12** is displayed on the screen.
34. Press Enter. Display should blink, indicating that the new value is set into memory.

35. Press Escape.
36. Press the down arrow until **tHP (Motor Thermal Protection Menu)** appears on screen.
37. Press Enter.
38. Press the down or up arrow until **20** appears on screen.
39. Press Enter. Display should blink, indicating that the new value is set into memory.
40. Press Escape.
41. Press Escape again. Display should show **SEt**.
42. Press the down arrow until **ADJ (Advanced Adjustments Menu)** appears on screen.
43. Press Enter.
44. Press the down arrow until **SSC (Start-stop control)** appears on screen.
45. Press Enter.
46. Press the down or up arrow until **oFF** appears on display.
47. Press Enter. Display should blink, indicating that new value is set into memory.
48. Press Escape.
49. Press Escape again. Display should show **ADJ**.
50. Press the down arrow until **PrO (Advanced Protections Menu)** appears on screen.
51. Press Enter.
52. Press the down arrow until **lth (Overload Protection)** appears on screen.
53. Press Enter.
54. Press the down arrow until **Erun** appears on screen.
55. Press Enter. Display should blink, indicating that the new value is set into memory.
56. Press Escape.
57. Press Escape again. Display should show **PrO**.
58. Press the down arrow until **IO (Advanced Input/Output Menu)** appears on screen.
59. Press Enter.
60. Press the down arrow until **r1 (Relay 1)** appears on screen.
61. Press Enter.
62. Press the down or up arrow until **Tr Ip** appears on screen.
63. Press Enter. Display should blink, indicating that the new value is set into memory.
64. Press the down or up arrow until **r2 (Relay 2)** appears on screen.
65. Press Enter.
66. Press the down or up arrow until **rUn** appears on screen.
67. Press Enter. Display should blink, indicating that the new value is set into memory.
68. Press Escape until **rdY** appears on display.

This concludes programming.

Motor Full Load Amps

Motor	Voltage	Full Load Amps	SF Amps	Part #	Soft Start	ATS #
50HP	208VAC	125	144	J6870	170A	ATS22C17S6U
	230VAC	117	135	J6870	170A	ATS22C17S6U
	380VAC	56	64.4	J6866	75A	ATS22D75S6U
	460VAC	58	66.7	J6866	75A	ATS22D75S6U
	575VAC	52		J6866	75A	
60HP	208VAC	147	169	J6871	210A	ATS22C21S6U
	230VAC	139	160	J6871	210A	ATS22C21S6U
	380VAC	70	80.5	J6868	110A	ATS22D11S6U
	460VAC	70	80	J6868	110A	ATS22C11S6U
	575VAC	54.8	63	J6866	75A	ATS22D75S6U
75HP	208VAC	187	215	J6872	250A	ATS22C22S6U
	230VAC	171	196	J6872	250A	ATS22C22S6U
	380VAC	83	95.4	J6868	110A	ATS22C11S6U
	460VAC	86	98.3	J6868	110A	ATS22C11S6U
	575VAC	68	78.2	J6867	88A	ATS22C88S6U
100HP	208VAC	254	292	J6873	320A	ATS22C32S6U
	230VAC	225	259	J6873	320A	ATS22C32S6U
	380VAC	101	116	J6869	140A	ATS22C14S6U
	460VAC	113	129	J6870	170A	ATS22C17S6U
	575VAC	91.7	105	J6869	140A	ATS22C14S6U
125HP	208VAC					
	230VAC					
	380VAC	133	166	J6871	210A	ATS22C21S6U
	460VAC	138	172	J6871	210A	ATS22C21S6U
	575VAC					

Troubleshooting ATS22 Soft Start for Towers

NOTE: The following pages are from Altistart 22 Soft Start User Manual, BBV51330, dated 09/2015. A complete copy can be found on Sukup website and at www.schneider-electric.com.

Diagnostics / Troubleshooting

Soft starter does not start, no trip code displayed

- No display:
 - check that the line supply is present on the control supply CL1/CL2,
 - check if a short circuit is not existing on the Modbus network cable (especially between RJ45 pin 7 and RJ45 pin3 or pin8. See pages 35 and 36).
- Check that the code displayed does not correspond to the normal state of the soft starter (see page 46).
- Check for the presence of the RUN/STOP commands (see page 37).

Soft starter does not start, trip code displayed

- Trip code flashes on the display.
- Storing of the last 7 trips, visible with SoMove software workshop.
- The soft starter locks and the motor stop with to freewheel mode.

⚠ ⚠ DANGER

HAZARD OF ELECTRIC SHOCK, EXPLOSION, OR ARC FLASH

- Read and understand the precautions in "Before you begin" chapter, before performing any procedure in this section.

Failure to follow these instructions will result in death or serious injury.

Trip code displayed	Name	Remedy
b P F	Bypass contactor detected fault	• Switch-off the soft starter and contact Schneider Electric services.
C F F	Invalid configuration on power-up	• Revert to the factory setting in the soft starter U E I L menu • Reconfigure the soft starter
E E F	External detected fault	• Clear the cause of the detected fault
G r d F	Ground leakage current detected fault	• Check the electrical insulation of the motor • Check the installation • Check the values of G r d d , G r d t parameters in P r D menu page 57
I n F	Internal detected fault	• Disconnect and reconnect the control supply. If the detected fault persists, contact Schneider Electric product support
O C F	Motor overcurrent	• Check the values of O I d and O I t parameters in P r D menu page 56
O H F	Over heat detected fault Low temperature detected fault	• Check the sizing of the soft starter in relation to the motor and the mechanical requirement • Check the operation of the fan (if the Altistart 22 used has one), ensuring that the air passage is not obstructed in any way and the heatsink is clean. Ensure that the mounting recommendations are observed • Wait for the Altistart 22 cooling before restarting, keeping the starter powered on
O L F	Overload motor	• Check the mechanism (wear, mechanical play, lubrication, blockages, etc.) • Check the sizing of the soft starter motor in relation to the mechanical requirement • Check the value of t H P parameter in S E t menu page 52 and I n parameter in c o n F menu page 50 • Wait for the motor to cool before restarting
O S F	Overvoltage	• Check U L n parameter in c o n F menu • Check the power supply circuit and voltage • Check O S d and O S t parameters in P r D menu
O t F	Motor Over Temperature • Motor thermal trip detected by the PTC probes	• Check the mechanism (wear, mechanical play, lubrication, blockages, etc.) • Check the sizing of the soft starter motor in relation to the mechanical requirement • Check the value of P t C setting in P r D menu page 59 • Wait for the motor to cool before restarting

Diagnostics / Troubleshooting

Trip code displayed	Name	Remedy
<i>PHb d</i>	Phase unbalance	<ul style="list-style-type: none"> Check the line voltage. Check the values of <i>Ubd</i>, <i>Ubt</i> parameters in <i>PrD</i> menu page 57.
<i>PHF</i>	Loss of a line phase	<ul style="list-style-type: none"> Check the line voltage, the connection to the soft starter and any isolating devices located between the line and the soft starter (contactors, fuses, circuit breakers, etc.). Check the motor connection and any isolating devices located between the soft starter and the motor (contactors, circuit breakers, etc.). Check the motor state.
	Line frequency, out of tolerance This detected fault can be configured in <i>PrD</i> menu	<ul style="list-style-type: none"> Check the line frequency. Check the configuration of <i>PHL</i>.
<i>PIF</i>	Phase inversion Line phase inversion does not conform to the selection made by <i>PHr</i> in <i>PrD</i> menu	<ul style="list-style-type: none"> Invert two lines phases or set <i>PHr</i> = <i>OFF</i>.
<i>ErAP</i>	Trap code	<ul style="list-style-type: none"> Disconnect and reconnect the control supply. If the detected fault persists, contact Schneider Electric support.
<i>SCF</i>	Short circuit: <ul style="list-style-type: none"> short-circuit on soft starter output 	<ul style="list-style-type: none"> Switch-off the soft starter. Check the motor connections and the motor insulation. If connections and insulation are OK, contact Schneider Electric services.
<i>SLF</i>	Modbus Time Out	<ul style="list-style-type: none"> Serial link detected fault. Check the RS485 connection.
<i>SnbF</i>	Too many starts	<ul style="list-style-type: none"> The number of soft starts has exceeded the maximum allowed by <i>Snb</i> in <i>SLG</i> period. See <i>Snb</i> page 53.
<i>SSCr</i>	Shorted thyristor or wrong connection	<ul style="list-style-type: none"> Switch-off the soft starter. Check the motor connections and the motor insulation. If connections and insulation are OK, contact Schneider Electric services.
<i>SEF</i>	Starting time detected fault <ul style="list-style-type: none"> Too long start time 	<ul style="list-style-type: none"> Check the mechanism (wear, mechanical play, lubrication, blockages, etc.) Check that <i>EL5</i> (Max start time) is bigger than <i>ACC</i> (Acceleration time). See <i>SEt</i> menu page 51. Check the sizing of the soft starter motor in relation to the mechanical requirement Check <i>ILt</i> value : if the value is too low, the motor may not reach acceleration and full speed.
<i>tbS</i>	Too many starts	<ul style="list-style-type: none"> Wait 5 minutes for frame size A. Wait 15 minutes for frame sizes B, C, D and E. <i>tbS</i> appears after <i>SnbF</i> trip message, when trying to reset the soft starter before end of the timer.
<i>UCF</i>	Motor underload (undercurrent)	<ul style="list-style-type: none"> Check the values of <i>Uld</i> and <i>Ule</i> parameters in <i>PrD</i> menu page 57.
<i>USF</i>	Under voltage or no voltage	<ul style="list-style-type: none"> Check <i>Uln</i>, <i>USd</i> and <i>USe</i> parameters in <i>PrD</i> menu Check line voltage.

Remote keypad messages

Display	Message	Description
<i>InIt</i>		On initializing itself Microcontroller initializing. Communication configuration searching.
<i>CDNE</i>	flashing	Communication interruption It has 50 ms time out. This message is shown after 20 times retrying.
<i>A-17</i>	flashing	Key alarm <ul style="list-style-type: none"> Key has been held consecutively more than 10 seconds. Membrane switch disconnected. Keypad waked up while a key is holding.
<i>CLr</i>	flashing	Confirm trip reset This is shown when : First time STOP key has been pressed while the soft starter has tripped in detected fault.
<i>dEUE</i>	flashing	Soft starter mismatch Soft starter type (brand) did not match with keypad type (brand).
<i>rDNE</i>	flashing	ROM trip Keypad ROM detected fault.
<i>rANE</i>	flashing	RAM trip Keypad RAM detected fault.
<i>CPUE</i>	flashing	CPU trip Keypad CPU detected fault.

Appendix H

Altivar Variable Frequency Drive

**Programming ATV 320
VFD Starter Protector Settings
Troubleshooting ATV 320**

<u>DATE</u>	<u>REVISION</u>	<u>PAGE</u>
12/28/2022	– Removed VFD settings for discontinued 10' diameter dryers-----	H-3
	Updated Altivar VFD troubleshooting pages -----	H-4 – H-8

Programming Altivar 320 Variable Speed Drive

Use green jog dial for navigation by turning clockwise or counterclockwise. Pressing dial lets user make a selection or confirm information. Use adjacent ESC button to quit a menu or parameter or to clear value displayed in order to revert to value in memory.

1. Push dial once to get into menu system.
2. Turn dial to Configuration menu, (**ConF**); push dial to enter menu.
3. Enter each setting by following applicable pathway depending on dryer voltage (230V, 380V, etc.) and parameter (ITH, SDC1, etc.). Press Enter after each entry, then ESC until get to RDY.

Settings for 230V 3HP 3Ø 60HZ

<u>PATHWAY</u>	<u>PARAMETER</u>	<u>(DESCRIPTION)</u>	<u>SETTING</u>
RDY → CONF → FULL → SET → ITH		(Motor Thermal Current)	8A
RDY → CONF → FULL → SET → SDC1		(DC Injection Level 1)	7.7A
RDY → CONF → FULL → SET → SDC2		(DC Injection Level 2)	4A
RDY → CONF → FULL → SET → CLI		(Internal Current Limit)	12A
RDY → CONF → FULL → DRC → BFR		(Standard Motor Frequency)	60Hz NEMA
RDY → CONF → FULL → I-O → R2		(Relay Output 2 Assignment)	Drv. Running
RDY → CONF → FULL → FLT → OPL		(Output Phase Loss)	Yes
RDY → CONF → FULL → DRC → NRD		(Noise Reduction)	Yes
RDY → CONF → FULL → DRC → ASY → NSP		(Rated Motor Speed)	1750

Settings for 380V 3HP 3Ø 50HZ

<u>PATHWAY</u>	<u>PARAMETER</u>	<u>(DESCRIPTION)</u>	<u>SETTING</u>
RDY → CONF → FULL → SET → ITH		(Motor Thermal Current)	5.4A
RDY → CONF → FULL → SET → SDC1		(DC Injection Level 1)	3.8A
RDY → CONF → FULL → SET → SDC2		(DC Injection Level 2)	2.7A
RDY → CONF → FULL → SET → CLI		(Internal Current Limit)	8.1A
RDY → CONF → FULL → DRC → BFR		(Standard Motor Frequency)	50Hz NEMA
RDY → CONF → FULL → I-O → R2		(Relay Output 2 Assignment)	Drv. Running
RDY → CONF → FULL → FLT → OPL		(Output Phase Loss)	Yes
RDY → CONF → FULL → DRC → NRD		(Noise Reduction)	Yes
RDY → CONF → FULL → DRC → ASY → NSP		(Rated Motor Speed)	1750

Settings for 460V 3HP 3Ø 60HZ

<u>PATHWAY</u>	<u>PARAMETER</u>	<u>(DESCRIPTION)</u>	<u>SETTING</u>
RDY → CONF → FULL → SET → ITH		(Motor Thermal Current)	4A
RDY → CONF → FULL → SET → SDC1		(DC Injection Level 1)	3.8A
RDY → CONF → FULL → SET → SDC2		(DC Injection Level 2)	2A
RDY → CONF → FULL → SET → CLI		(Internal Current Limit)	6A
RDY → CONF → FULL → DRC → BFR		(Standard Motor Frequency)	60Hz NEMA
RDY → CONF → I FULL → -O → R2		(Relay Output 2 Assignment)	Drv. Running
RDY → CONF → FULL → FLT → OPL		(Output Phase Loss)	Yes
RDY → CONF → FULL → DRC → NRD		(Noise Reduction)	Yes
RDY → CONF → FULL → DRC → ASY → NSP		(Rated Motor Speed)	1750

Settings for 575V 3HP 3Ø 60HZ

<u>PATHWAY</u>	<u>PARAMETER</u>	<u>(DESCRIPTION)</u>	<u>SETTING</u>
RDY → CONF → FULL → SET → ITH		(Motor Thermal Current)	2.8A
RDY → CONF → FULL → SET → SDC1		(DC Injection Level 1)	2.7A
RDY → CONF → FULL → SET → SDC2		(DC Injection Level 2)	1.4A
RDY → CONF → FULL → SET → CLI		(Internal Current Limit)	5.8A
RDY → CONF → FULL → DRC → BFR		(Standard Motor Frequency)	60Hz NEMA
RDY → CONF → FULL → I-O → R2		(Relay Output 2 Assignment)	Drv. Running
RDY → CONF → FULL → FLT → OPL		(Output Phase Loss)	Yes
RDY → CONF → FULL → DRC → NRD		(Noise Reduction)	Yes
RDY → CONF → FULL → DRC → ASY → NSP		(Rated Motor Speed)	1750

Variable Frequency Drive Starter Protector Settings

3/4HP through 3HP, add 1.15 Service Factor to Starter Protector Settings

Motor Horsepower	Voltage	Method of Starting	Starter Protector Setting	Part #	Motor Chart Setting
1-1/2HP 12' Tower	208VAC	ALL	7.9AMP	J5236	6.9AMP
	230VAC		6.9AMP	J5236	6.0AMP
	380VAC		4.1AMP	J5234	3.6AMP
	460VAC		3.5AMP	J5234	3.0AMP
	575VAC		2.8AMP	J5233	2.4AMP
2HP 18' Tower	208VAC	ALL	9.0AMP	J5236	7.8AMP
	230VAC		7.8AMP	J5236	6.8AMP
	380VAC		6.7AMP	J5236	5.8AMP
	460VAC		3.9AMP	J5234	3.4AMP
	575VAC		3.1AMP	J5234	2.7AMP
3HP 24' Tower	380VAC	ALL	6.7AMP	J5236	5.8AMP
	460VAC		5.5AMP	J5234	4.8AMP
	575VAC		4.5AMP	J5234	3.9AMP

Troubleshooting Altivar 320 Variable Frequency Drive

NOTE: The following pages are from Altivar Machine ATV320 Variable Speed Drives Programming Manual, NVE41295, dated 09/2021. A complete copy can be found on Sukup website and at www.schneider-electric.com

Error code

- If the display does not light up, check the power supply to the drive.
- The assignment of the Fast stop or Freewheel functions will help to prevent the drive starting if the corresponding logic inputs are not powered up. The ATV320 then displays **[Freewheel]** (r 5 E) in freewheel stop and **[Fast stop]** (F 5 E) in fast stop. This is normal since these functions are active at zero so that the drive will be stopped if there is a wire break.
- Check that the run command input is activated in accordance with the selected control mode (**[2/3 wire control]** (E C C) and **[2 wire type]** (E C E) parameters, page 93).
- If an input is assigned to the limit switch function and this input is at zero, the drive can only be started up by sending a command for the opposite direction (see page 236).
- If the reference channel or command channel is assigned to a communication bus, when the power supply is connected, the drive will display **[Freewheel]** (r 5 E) and remain in stop mode until the communication bus sends a command.

Code	Name / Description
d G E -	[DIAGNOSTICS] This menu can only be accessed with the graphic display terminal. It displays detected faults and their cause in plain text and can be used to carry out tests, see page 72.

Clearing the detected fault

In the event of a non resettable detected fault:

- Disconnect all power, including external control power that may be present.
- Lock all power disconnects in the open position.
- Wait 15 minutes to allow the DC bus capacitors to discharge (the drive LEDs are not indicators of the absence of DC bus voltage).
- Measure the voltage of the DC bus between the PA/+ and PC/- terminals to ensure that the voltage is less than 42 Vdc.
- If the DC bus capacitors do not discharge completely, contact your local Schneider Electric representative. Do not repair or operate the drive.
- Find and correct the detected fault.
- Restore power to the drive to confirm the detected fault has been rectified.

In the event of a resettable detected fault, the drive can be reset after the cause is cleared:

- By switching off the drive until the display disappears completely, then switching on again.
- Automatically in the scenarios described for the **[AUTOMATIC RESTART]** (R E r -) function, page 266.
- By means of a logic input or control bit assigned to the **[FAULT RESET]** (r 5 E -) function, page 265.
- By pressing the STOP/RESET key on the graphic display keypad if the active channel command is the HMI (see **[Cmd channel 1]** (C d l) page 164).

Fault detection codes which require a power reset after the detected fault is cleared

The cause of the detected fault must be removed before resetting by turning off and then back on.

RSF, *brF*, *SoF*, *SPF* and *LnF* detected faults can also be cleared remotely by means of a logic input or control bit (**[Fault reset] (rSF)** parameter, page 265).

Detected Fault	Name	Probable cause	Remedy
<i>LnF</i>	[Load slipping]	<ul style="list-style-type: none"> The difference between the output frequency and the speed feedback is not correct. 	<ul style="list-style-type: none"> Check the motor, gain and stability parameters. Add a braking resistor. Check the size of the motor/drive/load. Check the encoder's mechanical coupling and its wiring. Check the setting of parameters
<i>RSF</i>	[Angle Error]	<ul style="list-style-type: none"> This occurs during the phase-shift angle measurement, if the motor phase is disconnected or if the motor inductance is too high. 	<ul style="list-style-type: none"> Check the motor phases and the maximum current allowed by the drive.
<i>brLF</i>	[Brake control]	<ul style="list-style-type: none"> Brake release current not reached. Brake engage frequency threshold [Brake engage freq] (<i>brEn</i>) only regulated when brake logic control is assigned. 	<ul style="list-style-type: none"> Check the drive/motor connection. Check the motor windings. Check the [Brake release I FW] (<i>brI</i>) and [Brake release I Rev] (<i>brd</i>) settings page 206. Apply the recommended settings for [Brake engage freq] (<i>brEn</i>).
<i>brF</i>	[Brake feedback]	<ul style="list-style-type: none"> The brake feedback contact does not match the brake logic control. The brake does not stop the motor quickly enough (detected by measuring the speed on the "Pulse input" input). 	<ul style="list-style-type: none"> Check the feedback circuit and the brake logic control circuit. Check the mechanical state of the brake. Check the brake linings.
<i>CrFI</i>	[Precharge]	<ul style="list-style-type: none"> Charging relay control detected fault or charging resistor damaged. 	<ul style="list-style-type: none"> Turn the drive off and then turn on again. Check the internal connections. Contact Schneider Electric Product Support.
<i>EEF1</i>	[Control Eeprom]	<ul style="list-style-type: none"> Internal memory detected fault, control block. 	<ul style="list-style-type: none"> Check the environment (electromagnetic compatibility). Turn off, reset, return to factory settings.
<i>EEF2</i>	[Power Eeprom]	<ul style="list-style-type: none"> Internal memory detected fault, power card. 	<ul style="list-style-type: none"> Contact Schneider Electric Product Support.
<i>CCFI</i>	[Out. contact. stuck]	<ul style="list-style-type: none"> The output contactor remains closed although the opening conditions have been met. 	<ul style="list-style-type: none"> Check the contactor and its wiring. Check the feedback circuit.
<i>HdF</i>	[IGBT desaturation]	<ul style="list-style-type: none"> Short-circuit or grounding at the drive output. 	<ul style="list-style-type: none"> Check the cables connecting the drive to the motor, and the motor insulation.
<i>ILF</i>	[internal com. link]	<ul style="list-style-type: none"> Communication interruption between option card and drive. 	<ul style="list-style-type: none"> Check the environment (electromagnetic compatibility). Check the connections. Replace the option card. Contact Schneider Electric Product Support.
<i>inF1</i>	[Rating error]	<ul style="list-style-type: none"> The power card is different from the card stored. 	<ul style="list-style-type: none"> Check the reference of the power card.
<i>inF2</i>	[Incompatible PB]	<ul style="list-style-type: none"> The power card is incompatible with the control block. 	<ul style="list-style-type: none"> Check the reference of the power card and its compatibility.
<i>inF3</i>	[Internal serial link]	<ul style="list-style-type: none"> Communication interruption between the internal cards. 	<ul style="list-style-type: none"> Check the internal connections. Contact Schneider Electric Product Support.
<i>inF4</i>	[Internal-mfg zone]	<ul style="list-style-type: none"> Internal data inconsistent. 	<ul style="list-style-type: none"> Recalibrate the drive (performed by Schneider Electric Product Support).
<i>inF5</i>	[Internal - fault option]	<ul style="list-style-type: none"> The option installed in the drive is not recognized. 	<ul style="list-style-type: none"> Check the reference and compatibility of the option. Check that the option is well inserted into the ATV320.
<i>inF9</i>	[Internal- I measure]	<ul style="list-style-type: none"> The current measurements are incorrect. 	<ul style="list-style-type: none"> Replace the current sensors or the power card. Contact Schneider Electric Product Support.
<i>inFA</i>	[Internal-mains circuit]	<ul style="list-style-type: none"> The input stage is not operating correctly. 	<ul style="list-style-type: none"> Contact Schneider Electric Product Support.
<i>inFb</i>	[Internal- th. sensor]	<ul style="list-style-type: none"> The drive temperature sensor is not operating correctly. 	<ul style="list-style-type: none"> Replace the drive temperature sensor. Contact Schneider Electric Product Support.

Detected Fault	Name	Probable cause	Remedy
<i>i n F E</i>	[Internal- CPU]	<ul style="list-style-type: none"> Internal microprocessor detected fault. 	<ul style="list-style-type: none"> Turn off and reset. Contact Schneider Electric Product Support.
<i>S A F F</i>	[Safety fault]	<ul style="list-style-type: none"> Debounce time exceeded. SS1 threshold exceeded. Wrong configuration. SLS type overspeed detected. 	<ul style="list-style-type: none"> Check the safety functions configuration. Check the ATV320 Integrated safety Functions manual Contact Schneider Electric Product Support.
<i>S o F</i>	[Overspeed]	<ul style="list-style-type: none"> Instability or driving load too high. If a downstream contactor is used, the contacts between the motor and the drive have not been closed before applying a Run command. The overspeed threshold (corresponding to 110 % of [Max frequency] (<i>£ F r</i>)) has been reached. 	<ul style="list-style-type: none"> Check the motor, gain and stability parameters. Add a braking resistor. Check the size of the motor/drive/load. Check the parameters settings for the [FREQUENCY METER] (<i>F 9 F -</i>) function page 280, if it is configured. Verify and close the contacts between the motor and the drive before applying a Run command. Verify the consistency between [Max frequency] (<i>£ F r</i>) and [High Speed] (<i>H S P</i>). It is recommended to have at least [Max frequency] (<i>£ F r</i>) ≥ 110% * [High Speed] (<i>H S P</i>).
<i>S P F</i>	[Speed fdback loss]	<ul style="list-style-type: none"> Signal on "Pulse input" missing, if the input is used for speed measurement. Encoder feedback signal missing 	<ul style="list-style-type: none"> Check the wiring of the input cable and the detector used. Check the configuration parameters of the encoder. Check the wiring between the encoder and the drive. Check the encoder.

Fault detection codes that can be cleared with the automatic restart function after the cause has disappeared

These detected faults can also be cleared by turning on and off or by means of a logic input or control bit ([Fault reset] (*r S F*) parameter page 265).

Detected Fault	Name	Probable cause	Remedy
<i>£ n F</i>	[Com. network]	<ul style="list-style-type: none"> Communication interruption on communication card. 	<ul style="list-style-type: none"> Check the environment (electromagnetic compatibility). Check the wiring. Check the time-out. Replace the option card. Contact Schneider Electric Product Support.
<i>£ o F</i>	[CANopen com.]	<ul style="list-style-type: none"> Communication interruption on the CANopen® bus. 	<ul style="list-style-type: none"> Check the communication bus. Check the time-out. Refer to the CANopen® User's manual.
<i>E P F 1</i>	[External fit-LI/Bit]	<ul style="list-style-type: none"> Event triggered by an external device, depending on user. 	<ul style="list-style-type: none"> Check the device which caused the triggering and reset.
<i>E P F 2</i>	[External fault com.]	<ul style="list-style-type: none"> Event triggered by a communication network. 	<ul style="list-style-type: none"> Check for the cause of the triggering and reset.
<i>F b E 5</i>	[FB stop fit.]	<ul style="list-style-type: none"> Function blocks have been stopped while motor was running. 	<ul style="list-style-type: none"> Check [Stop FB Stop motor] (<i>F b 5 P</i>) configuration.
<i>F £ F 2</i>	[Out. contact. open.]	<ul style="list-style-type: none"> The output contactor remains open although the closing conditions have been met. 	<ul style="list-style-type: none"> Check the contactor and its wiring. Check the feedback circuit.
<i>L £ F</i>	[input contactor]	<ul style="list-style-type: none"> The drive is not turned on even though [Mains V. time out] (<i>L £ £</i>) has elapsed. 	<ul style="list-style-type: none"> Check the contactor and its wiring. Check the time-out. Check the supply mains/contactor/drive connection.
<i>L F F 3</i>	[AI3 4-20mA loss]	<ul style="list-style-type: none"> Loss of the 4-20 mA reference on analog input AI3. 	<ul style="list-style-type: none"> Check the connection on the analog inputs.
<i>o b F</i>	[Overbraking]	<ul style="list-style-type: none"> Braking too sudden or driving load. Supply voltage too high. 	<ul style="list-style-type: none"> Increase the deceleration time. Install a braking resistor if necessary. Activate the [Dec ramp adapt.] (<i>b r A</i>) function page 181, if it is compatible with the application. Check the supply voltage.
<i>o £ F</i>	[Overcurrent]	<ul style="list-style-type: none"> Parameters in the [SETTINGS] (<i>S E £ -</i>) and [MOTOR CONTROL] (<i>d r £ -</i>) menus are not correct. Inertia or load too high. Mechanical locking. 	<ul style="list-style-type: none"> Check the parameters. Check the size of the motor/drive/load. Check the state of the mechanism. Decrease [Current limitation] (<i>£ L r</i>). Increase the switching frequency.
<i>o H F</i>	[Drive overheat]	<ul style="list-style-type: none"> Drive temperature too high. 	<ul style="list-style-type: none"> Check the motor load, the drive ventilation and the ambient temperature. Wait for the drive to cool down before restarting.
<i>o L £</i>	[Proc. overload fit]	<ul style="list-style-type: none"> Process overload. 	<ul style="list-style-type: none"> Check and remove the cause of the overload. Check the parameters of the [PROCESS OVERLOAD] (<i>o L d -</i>) function, page 286.
<i>o L F</i>	[Motor overload]	<ul style="list-style-type: none"> Triggered by excessive motor current. 	<ul style="list-style-type: none"> Check the setting of the motor thermal protection, check the motor load. Wait for the motor to cool down before restarting.
<i>o P F 1</i>	[1 output phase loss]	<ul style="list-style-type: none"> Loss of one phase at drive output. 	<ul style="list-style-type: none"> Check the connections from the drive to the motor.

Detected Fault	Name	Probable cause	Remedy
o P F 2	[3 motor phase loss]	<ul style="list-style-type: none"> • Motor not connected or motor power too low. • Output contactor open. • Instantaneous instability in the motor current. 	<ul style="list-style-type: none"> • Check the connections from the drive to the motor. • If an output contactor is being used, set [Output Phase Loss] (o P L) to [Output cut] (o R C), page 270. • Test on a low power motor or without a motor: In factory settings mode, motor phase loss detection is active [Output Phase Loss] (o P L) = [Yes] (Y E 5). To check the drive in a test or maintenance environment, without having to use a motor with the same rating as the drive (in particular for high power drives), deactivate motor phase loss detection [Output Phase Loss] (o P L) = [No] (n o), see instructions given page 270. • Check and optimize the following parameters: [IR compensation] (u F r) page 99, [Rated motor volt.] (u n 5) and [Rated mot. current] (n L r) page 94 and perform [Auto tuning] (t u n) page 95.
o S F	[Mains overvoltage]	<ul style="list-style-type: none"> • Supply voltage too high. • Disturbed mains supply. 	<ul style="list-style-type: none"> • Check the supply voltage.
o t F L	[LI6=PTC overheat]	<ul style="list-style-type: none"> • Overheating of PTC probes detected on input LI6. 	<ul style="list-style-type: none"> • Check the motor load and motor size. • Check the motor ventilation. • Wait for the motor to cool before restarting. • Check the type and state of the PTC probes.
P t F L	[LI6=PTC probe]	<ul style="list-style-type: none"> • PTC probe on input LI6 open or short-circuited. 	<ul style="list-style-type: none"> • Check the PTC probe and the wiring between it and the motor/drive.
S C F 1	[Motor short circuit]	<ul style="list-style-type: none"> • Short-circuit or grounding at the drive output. 	<ul style="list-style-type: none"> • Check the cables connecting the drive to the motor, and the motor insulation. • Reduce the switching frequency. • Connect chokes in series with the motor. • Check the adjustment of speed loop and brake. • Increase the [Time to restart] (t t r), page 109. • Increase the switching frequency.
S C F 3	[Ground short circuit]	<ul style="list-style-type: none"> • Significant earth leakage current at the drive output if several motors are connected in parallel. 	<ul style="list-style-type: none"> • Check the cables connecting the drive to the motor, and the motor insulation. • Reduce the switching frequency. • Connect chokes in series with the motor. • Check the adjustment of speed loop and brake. • Increase the [Time to restart] (t t r), page 109. • Reduce the switching frequency.
S C F 4	[IGBT short circuit]	<ul style="list-style-type: none"> • Power component detected fault. 	<ul style="list-style-type: none"> • Contact Schneider Electric Product Support.
S C F 5	[Motor short circuit]	<ul style="list-style-type: none"> • Short-circuit at drive output. 	<ul style="list-style-type: none"> • Check the cables connecting the drive to the motor, and the motor's insulation. • Contact Schneider Electric Product Support.
S L F 1	[Modbus com.]	<ul style="list-style-type: none"> • Communication interruption on the Modbus bus. 	<ul style="list-style-type: none"> • Check the communication bus. • Check the time-out. • Refer to the Modbus User's manual.
S L F 2	[PC com.]	<ul style="list-style-type: none"> • Communication interruption with PC Software. 	<ul style="list-style-type: none"> • Check the PC Software connecting cable. • Check the time-out.
S L F 3	[HMI com.]	<ul style="list-style-type: none"> • Communication interruption with the graphic display terminal or remote display terminal. 	<ul style="list-style-type: none"> • Check the terminal connection • Check the time-out.
S S F	[Torque/current lim]	<ul style="list-style-type: none"> • Switch to torque or current limitation. 	<ul style="list-style-type: none"> • Check if there are any mechanical problems. • Check the parameters of [TORQUE LIMITATION] (t o L -) page 228 and the parameters of the [TORQUE OR I LIM. DETECT.] (t i d -), page 278.
t J F	[IGBT overheat]	<ul style="list-style-type: none"> • Drive overheated. 	<ul style="list-style-type: none"> • Check the size of the load/motor/drive. • Reduce the switching frequency. • Wait for the motor to cool before restarting.
t n F	[Auto-tuning]	<ul style="list-style-type: none"> • Special motor or motor whose power is not suitable for the drive. • Motor not connected to the drive. • Motor not stopped 	<ul style="list-style-type: none"> • Check that the motor/drive are compatible. • Check that the motor is present during auto-tuning. • If an output contactor is being used, close it during auto-tuning. • Check that the motor is stopped during tune operation.
u L F	[Proc. underload Fit]	<ul style="list-style-type: none"> • Process underload. 	<ul style="list-style-type: none"> • Check and remove the cause of the underload. • Check the parameters of the [PROCESS UNDERLOAD] (u L d -) function, page 284.

Fault detection codes that are cleared as soon as their cause disappears

Detected Fault	Name	Probable cause	Remedy
CFF	[Incorrect config.]	<ul style="list-style-type: none"> Option card changed or removed. Control block replaced by a control block configured on a drive with a different rating. The current configuration is inconsistent. 	<ul style="list-style-type: none"> Check that there are no card errors. In the event of the option card being changed/removed deliberately, see the remarks below. Check that there are no card errors. In the event of the control block being changed deliberately, see the remarks below. Return to factory settings or retrieve the backup configuration, if it is valid (see page 89).
CF1 CF12	[Invalid config.]	<ul style="list-style-type: none"> Invalid configuration. The configuration loaded in the drive via the bus or communication network is inconsistent. 	<ul style="list-style-type: none"> Check the configuration loaded previously. Load a compatible configuration.
CSF	[Ch. Sw. fault]	<ul style="list-style-type: none"> Switch to not valid channels. 	<ul style="list-style-type: none"> Check the function parameters.
dLF	[Dynamic load fault]	<ul style="list-style-type: none"> Abnormal load variation. 	<ul style="list-style-type: none"> Check that the load is not blocked by an obstacle. Removal of a run command causes a reset.
FbE	[FB fault]	<ul style="list-style-type: none"> Function blocks error. 	<ul style="list-style-type: none"> See [FB Fault] (FbFt) for more details.
HCF	[Cards pairing]	<ul style="list-style-type: none"> The [CARDS PAIRING] (PP, -) function page 283 has been configured and a drive card has been changed. 	<ul style="list-style-type: none"> In the event of a card error, reinsert the original card. Confirm the configuration by entering the [Pairing password] (PP,) if the card was changed deliberately.
PHF	[Input phase loss]	<ul style="list-style-type: none"> Drive incorrectly supplied or a fuse blown. One phase missing. 3-phase ATV320 used on a single-phase supply mains. Unbalanced load. <p>This protection only operates with the drive on load.</p>	<ul style="list-style-type: none"> Check the power connection and the fuses. Use a 3-phase supply mains. Disable the detected fault by [Input phase loss] (, PL) = [No] (no) page 94.
uSF	[Undervoltage]	<ul style="list-style-type: none"> Supply mains too low. Transient voltage dip. 	<ul style="list-style-type: none"> Check the voltage and the parameters of [UNDERVOLTAGE MGT] (u5b-), page 273.

Option card changed or removed

When an option card is removed or replaced by another, the drive locks in [Incorrect config.] (CFF) fault mode on power-up. If the card has been deliberately changed or removed, the detected fault can be cleared by pressing the ENT key twice, which causes the factory settings to be restored (see page 89) for the parameter groups affected by the card. These are as follows:

Card replaced by a card of the same type

- Communication cards: only the parameters that are specific to communication cards

Control block changed

When a control block is replaced by a control block configured on a drive with a different rating, the drive locks in [Incorrect config.] (CFF) fault mode on power-up. If the control block has been deliberately changed, the detected fault can be cleared by pressing the ENT key twice, which causes all the factory settings to be restored.

Fault detection codes displayed on the remote display terminal

Code	Name	Description
inib	[Initialization in progress]	The microcontroller is initializing. Search underway for communication configuration.
CoPE (1)	[Communication error]	Time out detected fault (50 ms). This message is displayed after 20 attempts at communication.
A-17 (1)	[Alarm button]	A key has been held down for more than 10 seconds. The keypad is disconnected. The keypad wakes up when a key is pressed.
CLr (1)	[Confirmation of detected fault reset]	This is displayed when the STOP key is pressed once if the active command channel is the remote display terminal.
dEu.E (1)	[Drive disparity]	The drive brand does not match that of the remote display terminal.
roPE (1)	[ROM anomaly]	The remote display terminal detects a ROM anomaly on the basis of checksum calculation.
rRPE (1)	[RAM anomaly]	The remote display terminal detects a RAM anomaly.
CPu.E (1)	[Other detected faults]	Other detected faults.

(1) Flashing

Appendix I

Burner Control Unit LME 69

**Enabling Diagnostics
Reading Error Codes**

Operation, display, diagnostics (cont'd)

Diagnostics of the cause of fault

After lockout, the red fault signal lamp remains steady on. In that condition, the visual diagnostics of the cause of fault according to the error code table can be activated by pressing the lockout reset button for more than 3 seconds. Pressing the reset button again for at least 3 seconds, the interface diagnostics will be activated. Interface diagnostics works only if the AGK20... lockout reset button extension is not fitted. If, by accident, interface diagnostics has been activated, in which case the slightly red light of the signal lamp LED flickers, it can be deactivated by pressing again the lockout reset button for at least 3 seconds. The instant of switching over is indicated by a yellow light pulse.

The following sequence activates the diagnostics of the cause of fault:

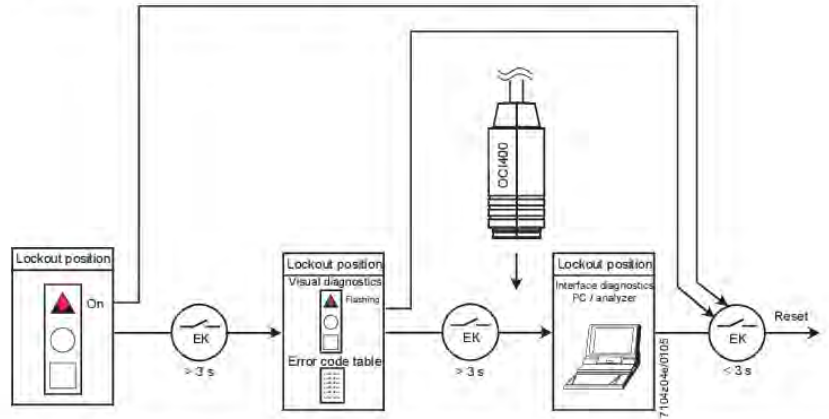

Error code table		
Red blink code of signal lamp (LED)	«AL» at term. 10	Possible cause
2 blinks	On	No establishment of flame at the end of safety time «TSA» - Faulty or soiled fuel valves - Faulty or soiled flame detector - Poor adjustment of burner, no fuel - Faulty ignition equipment
3 x blinks	On	Air pressure switch «LP» faulty - No or faulty air pressure signal after completion of specified time «t10» - Air pressure switch «LP» is welded in no-load position
4 blinks	On	Extraneous light when burner startup
5 blinks	On	Free
6 blinks	On	Free
7 blinks	On	Too many losses of flame during operation (limitation of repetitions) - Faulty or soiled fuel valves - Faulty or soiled flame detector - Poor adjustment of burner
8 blinks	On	Free
9 blinks	On	Free
10 blinks	Off	Wiring error or internal error, output contacts, other faults

During the time the cause of fault is diagnosed, the control outputs are deactivated.

- Burner remains shut down
- External fault indication remains deactivated
- Fault status signal «AL» at terminal 10, according to the error code table

The diagnostics of the cause of fault is quit and the burner switched on again by resetting the burner control. Press the lockout reset button for about 1 second (< 3 seconds).

Appendix J

Optional Features

**Creating MySukup.com Account
Auxiliary Motor Control Wiring**

<u>DATE</u>	<u>REVISION</u>	<u>PAGE</u>
12/28/2022	Removed instructions for discontinued GSM Modem Added Step 1d to order MySukup.com service; added T-shooting instructions - J-2, J-4 & J-5	

Creating/Managing MySukup.com Account & Connecting Devices

Follow instructions below to create and manage a MySukup.com account and connect devices to it. If you already have an account you can just log in to manage, even if you are the owner of another site. There is no reason to have two My Sukup accounts.

Internet Setup for QuadraTouch Pro Console or Master Site Controller:

1. Connect internet service to X3 Ethernet port on bottom of touch panel. See picture.

NOTE: Internet should not be hooked up to switch in main power box of dryer. If there is a cable running to switch in dryer power box and one to X3 port, it can cause issues with network repair utility.

2. If required, run Network Repair Utility and enable “Check for Internet” function. This fixes 99% of problems.
 - a. In rare instances, IT personnel may be needed to set up a custom configuration.



X3 Ethernet port (circled) in touch panel box

NOTE: Purchase and install Ethernet coupler, cap & housing (J8715) to ensure watertight connection of internet cable to touch panel box. Purchase 3' cable (J8717) to run from coupler to X3 port.

Connecting Dryer or Entire Site to New MySukup.com Account:

1. On the QuadraTouch Pro console (for Dryer-Only Site) or the Master Site Controller (if available):
 - a. Click Tools → Connectivity Tools → Remote Access Menu → Disabled to Enable Remote Access
 - b. Click “I Accept” to the GDPR Statement.
 - c. Click “Setup My Sukup Connection” to obtain the Device ID and Device PIN.
 - d. Share Device ID with your Sukup Dryer dealer, who will need it to order the service (found on Dealer Portal under Maintenance → Purchase Remote Web Access).

NOTES:

- If QuadraTouch Pro touchscreen console is connected to Internet, it may automatically download a Windows update and reboot, which will shut down the dryer. To prevent this on Version 3.0 software, go to: Tools → Update Tools → Disable Windows Update.
- Imaging a touchscreen will re-enable Windows updates. To disable, unplug console from Internet. Perform imaging as described in Installation Instructions L1931. When imaging is complete, follow process above to disable updates. After disabling updates, reconnect Internet.
- Windows updates may be necessary to prevent problems such as computer viruses. If Windows updates are disabled during drying season, enable them and leave touchscreen on for a week prior to next drying season.

2. Open a web browser and go to <http://www.mysukup.com/>
 3. Click “Create an Account”
 - a. Read Terms and Conditions and check “I Accept”.
 - b. After following directions to create an account, you will be sent a confirmation email.
 - c. Open email and click link provided.
 - d. Your account is now verified.
 4. Log in to your My Sukup account.
 5. On the right, click “Add New Site”. It will ask for the Device ID and Device PIN (obtained in Step 1.c.)
 6. On the My Sukup website, enter Device ID and Device PIN in the fields provided.
 7. Confirm that you entered them correctly and accept the terms and conditions.
 8. Click “Finish”.
 9. Congratulations! Your site is now connected to your My Sukup account.
- NOTE:** It might take up to two minutes to link the site with internet access.

Transferring Site to New Owner:

1. Open a web browser and go to <http://www.mysukup.com/>
 2. Log in as site owner.
 3. Find the site you wish to transfer.
 4. Next to site name there is a drop-down arrow. Click it and click on “Manage Users”.
 5. Find the user you wish to make a site owner. If user is not listed, follow Add User instructions.
 6. Click “Edit Symbol” under Role. (Symbol is a pencil in a box.)
 7. Change Role to Site Owner.
 8. Click “Save Role”.
 9. That user can then log in and remove you as the owner to complete the process.
- NOTE:** Sites can have more than one owner. They may have to logout/login to update permissions.

Adding User/Viewer to Your Site:

1. Open a web browser and go to <http://www.mysukup.com/>
 2. Log in as Site Owner.
 3. Find the site for which you wish to add a user.
 4. Next to site name there is a drop-down arrow. Click it and click on “Invite”.
 5. Enter name and email address of the person you wish to add to the site.
- NOTE:** Person being added does not have to have a My Sukup account yet, but it is OK if he/she does.
6. Click “Send Invitation”.
 7. The user will be added after the user creates an account (if needed) and logs in and clicks “I Accept” in their notifications.
- NOTE:** Invites will time out after 72 hours (three days).

Editing Permissions for a User:

1. Open a web browser and go to <http://www.mysukup.com/>
2. Log in as site owner.
3. Find the site for which you wish to edit a user permission.
4. Next to site name there is a drop-down arrow. Click it and click on “Manage Users”.
5. Find the user whose role you wish to edit.
6. Click “Edit Symbol” under Role. (Symbol is a pencil in a box.)
7. Change permission.
8. Click “Save Role”.
9. User permissions have been changed.

Removing a User from Site:

1. Open a web browser and go to <http://www.mysukup.com/>
2. Log in as site owner.
3. Find the site for which you wish to remove a user.
4. Next to site name there is a drop-down arrow. Click it and click on “Manage Users”.
5. Find the user whose role you wish to edit.
6. Click “Remove Symbol” under Name. (Red box with person icon and an “x”.)
7. Click “Yes, remove ‘User Name’”.
8. User has been removed from site.

Setting up Site Alerts:

1. Open a web browser and go to <http://www.mysukup.com/>
2. Log in.
3. In top right of the screen click person icon and click “Profile Settings”.
4. Enter mobile phone number in field provided.
5. Select mobile carrier.
6. Enter your email address in Confirm Email field provided.
7. Click “Save.”
8. Find site for which you wish to set up alerts.
9. Next to site name there is a drop-down arrow. Click it and click “Manage Site Alarm”.
10. At top right, click on Site Alarm Settings.
11. Click “Set Site Alarm to Default”.
12. Site alarms have been configured, you may customize as you see fit.

Troubleshooting

1. Make sure software is updated to V3.01 on both HMI and PLC. There were many connectivity improvements in V3.01. **Please don't call for help with mysukup.com before updating to V3.01 since update may solve problem.**
2. Go to Tools → Connectivity Tools → Get Public IP. If an IP address appears within 15 seconds and all lights below it are green, there is a good Internet connection to dryer. If no IP address appears, select Network Repair Utility under the Connectivity Tools menu and follow directions on screen. If you cannot get IP address and all lights below it are green, contact your IT professional.

3. On your mobile device, signed into your MySukup.com account, select Home button and refresh your Internet browser. You should see your Site Name. If it is in a green box, go to Step 4. If it is in a red box, perform Step 4 and then Step 5.
4. If your dryer site is shown in green on Home screen and was previously working but stopped, reboot router, wait 2 minutes and reboot touchscreen.
5. If dryer site is shown in red on Home screen, it is not linked to dryer.
 - a. On touchscreen, select Tools → Connectivity Tools Menu → Remote Access Menu. Make sure red box says Enabled, then click Setup MySukup Connection and see if it shows the Device ID or a Site ID. If Site ID, this means someone else has connected using the Device ID and blocked your access.
 - b. Click back and select Enable button to change it to Disable. Wait 10 seconds. This unlinks the dryer from the MySukup account. Then push Disable, change it back to Enable, click Setup MySukup Connection and wait 1 minute for it to connect.
 - c. If screen changes and shows a Site ID, then refresh browser on your device and see if site turns green on home screen. If not, repeat these steps until site on your device turns green, or until touchscreen stops showing a Site ID. Then do Repair/Replace on your site.

TROUBLESHOOTING NOTES:

- When adding another person or account to a dryer, site owner must invite that person by going to HOME on MySukup, clicking on drop-down menu and selecting Invite. New user will get an email with a link to connect.

- If another user tried to add dryer to his or her MySukup account by clicking Add New Site and using the Device ID, it will disconnect the original site owner. In this case, original site owner must select Repair & Replace from drop-down menu on Home screen.

Auxiliary Motor Control Wiring

Auxiliary motor control terminals are located in main power box. First picture shows terminals and second shows K relays for auxiliaries. There are eight (8) optional control circuits – four for loading system (K12 through K15) and four for unloading system (K16 through K19).

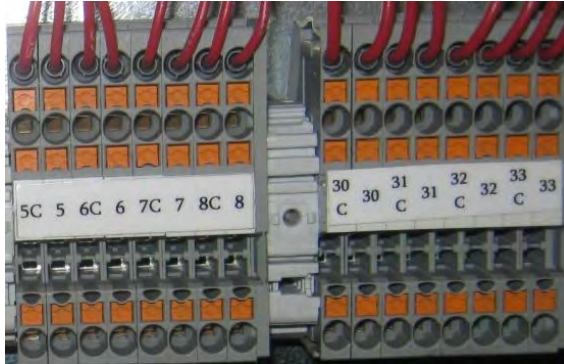

Customer Load/Unload DRY CONTACT terminals



K relays energized by 24VDC from PLC

AUXILIARY LOAD SYSTEM

NOTE: K relays are rated for 6 amps and are NOT fused.

Starting Load Sequence

1. Turn Load On
2. Call for Grain Signal
 - a. Fill Switch (Wire 53) Opens (If two fill switches used, both Wire 53 and Wire 44 must be open to start loading process).
 - b. Or Choke Fill is enabled
 - c. 24VDC Customer Load Interlock Wire 34 signals to PLC to that customer is ready. **NOTE:** Dryer ships with factory-installed jumper from Wire 18 to Wire 34.
3. When conditions above are met, a factory-programmed 10-second delay starts.

4. There is a user-defined load delay setting (Settings > Load Delay Timer)
 - a. Default is 0, 0-600 seconds range **NOTE:** This is in addition to 10-second factory-programmed delay.
5. Aux Load # 1 DRY CONTACTS are closed. K12 Relay. Wire 5 and Wire 5C are connected.
6. There is a user-defined time delay between Aux Load 1 and Aux Load 2.
 - a. Settings > Load Auxiliary Timers (Default is 5 seconds, 1-30 Sec Range)
7. Aux Load # 2 DRY CONTACTS are closed. K13 Relay. Wire 6 and Wire 6C are connected.
8. There is a user-defined time delay between Aux Load 2 and Aux Load 3.
 - a. Settings > Load Auxiliary Timers (Default is 5 seconds, 1-30 Sec Range)
9. Aux Load # 3 DRY CONTACTS are closed. K14 Relay. Wire 7 and Wire 7C are connected.
10. There is a user-defined time delay between Aux Load 3 and Aux Load 4.
 - a. Settings > Load Auxiliary Timers (Default is 5 seconds, 1-30 Sec Range)
11. Aux Load # 4 DRY CONTACTS are closed. K15 Relay. Wire 8 and Wire 8C are connected.

Stopping Load Sequence (Dryer Full)

NOTE: Turn Load Off (Manual Shutdown) will stop load sequence no matter the state of fill switch.

1. Fill switch (Wire 53) closes, sending 24VDC to PLC
2. Aux Load # 4 DRY CONTACTS are opened. K15 Relay. Wire 8 and Wire 8C are disconnected.
3. There is a user-defined time delay between Aux Load 3 and Aux Load 4.
4. Aux Load # 3 DRY CONTACTS are opened. K14 Relay. Wire 7 and Wire 7C are disconnected.
5. There is a user-defined time delay between Aux Load 2 and Aux Load 3.
6. Aux Load # 2 DRY CONTACTS are opened. K13 Relay. Wire 6 and Wire 6C are disconnected.
7. There is a user-defined time delay between Aux Load 1 and Aux Load 2.
8. Aux Load # 1 DRY CONTACTS are opened. K12 Relay. Wire 5 and Wire 5C are disconnected.

AUXILIARY UNLOAD SYSTEM

NOTE: K relays are rated for 6 amps and are NOT fused.

Starting Unload Sequence

1. Turn Unload On
2. Unload Aux # 4 DRY CONTACTS are closed. K16 Relay. Wire 30 and Wire 30C are connected.

3. There is a user-defined time delay between Aux Unload 3 and Unload Aux 4.
 - a. Settings > Unload Auxiliary Timers (Default is 3 seconds, 1-30 Sec Range)
4. Unload Aux # 3 DRY CONTACTS are closed. K17 Relay. Wire 31 and Wire 31C are connected.
5. There is a user-defined time delay between Aux Load 2 and Unload Aux 3.
 - a. Settings > Unload Auxiliary Timers (Default is 3 seconds, 1-30 Sec Range)
6. Unload Aux # 2 DRY CONTACTS are closed. K18 Relay. Wire 32 and Wire 32C are connected.
7. There is a user-defined time delay between Aux Load 1 and Unload Aux 2.
 - a. Settings > Unload Auxiliary Timers (Default is 3 seconds, 1-30 Sec Range)
8. Unload Aux # 1 DRY CONTACTS are closed. K19 Relay. Wire 33 and Wire 33C are connected.
9. There is a user-defined time delay between Tower Unload Table and Unload Aux 1.
 - a. Settings > Unload Auxiliary Timers (Default is 3 seconds, 1-30 Sec Range)
 - b. 24VDC Customer Unload Interlock Wire 35 Signal to PLC to tell it that customer is ready. **NOTE:** Dryer ships with factory installed jumper from Wire 18 to Wire 35.
10. Tower Unload Table Starts

Stopping Unload Sequence

NOTE: Turn Unload Off (Manual Shutdown) will start the stopping sequence.

1. Tower Unload Table Stops
2. There is a user-defined time delay between Tower Unload Table and Unload Aux 1.
3. Unload Aux # 1 DRY CONTACTS are opened. K19 Relay. Wire 33 and Wire 33C are disconnected.
4. There is a user-defined time delay between Unload Aux 1 and Unload Aux 2.
5. Unload Aux # 2 DRY CONTACTS are opened. K18 Relay. Wire 32 and Wire 32C are disconnected.
6. There is a user-defined time delay between Unload Aux 2 and Unload Aux 3.
7. Unload Aux # 3 DRY CONTACTS are opened. K17 Relay. Wire 31 and Wire 31C are disconnected.
8. There is a user-defined defined time delay between Unload Aux 3 and Unload Aux 4.
9. Unload Aux # 4 DRY CONTACTS are opened. K16 Relay. Wire 30 and Wire 30C are disconnected.



TOWER DRYER

SUPPLEMENTAL MANUAL

(Use with Manual L13892)

EU - Under Declaration of Incorporation

QuadraTouch Pro™
Dryer Control System



Sukup Manufacturing Co.

1555 255th Street, Box 677

Sheffield, Iowa USA 50475-0677

Phone: 641-892-4222

Fax: 641-892-4629

Website: www.sukup.com

E-mail: info@sukup.com

TABLE OF CONTENTS

General Safety Practices.....	3
Tower Dryer Safety Decals	5
Tower Dryer Decal Placement	7
Tower Dryer EU Safety Labels.....	8
Risk reduction for servicing dryer	10
Tower Dryer Specifications	11
Electrical Load Requirements	13
Tower Dryer Control Boxes	14
Training Register – Tower Grain Dryer.....	19
Ladder Placement	20
Contact Information.....	24

Concerning Regulations and Codes

Authorities having jurisdiction should be consulted before installations are begun. Equipment shall be installed in accordance with all current machinery and electrical codes.

All wiring and safety circuitry shall be completed by a qualified electrician in accordance with current editions of and in compliance with BS EN 60204-1:2006+A1:2009 and BS EN ISO 13849-1:2015. The recommendation after undertaking a risk assessment in accordance with BS EN ISO 13849-1: 2015 of the overall installation is to achieve a PLr of Category “d” and a designated architecture of Category 3.*

PLr : Performance level of the tower dryer door interlock safety function is in accordance with Annex A; BS EN ISO 13849-1:2015.

This is a supplemental manual specifically for the Sukup Manufacturing Co. Tower Dryer. Step by step instructions for installation, operation and maintenance appear in **Dryer Manual L13892**, along with a parts assembly for each specific Tower Dryer model.

NOTICE: Information in this manual is property of Sukup Manufacturing Co., Sheffield, Iowa, USA, and is provided on the condition that it will not be used in any way detrimental to the company’s interest. Reproduction of contents is prohibited unless express written consent is given from Sukup Manufacturing Co.

*BS EN ISO 13849-1: 2015. Section 3.0

PL : Performance level : Discrete level used to specify the ability of safety-related parts of control systems to perform a safety function under foreseeable conditions.

PLr : Required Performance level : Performance level (PL) applied in order to achieve the required risk reduction for each safety function.

GENERAL SAFETY PRACTICES



Read manual before installing or using product. Failure to follow instructions and safety precautions in manual can result in death or serious injury. Keep manual in a safe location for future reference.



On safety decals, this symbol and the signal words Danger, Warning, Caution and Notice draw your attention to important instructions regarding safety. They indicate potential hazards and levels of intensity.



DANGER indicates an imminently hazardous situation, which, if not avoided, will result in death or serious injury.



WARNING indicates a potentially hazardous situation, which, if not avoided, could result in death or serious injury.



CAUTION indicates a potentially hazardous situation, which, if not avoided, may result in minor or moderate injury.



NOTICE alerts you to practices unrelated to personal injury, such as messages related to property damage.

IMPORTANT: To prevent serious injury or death to you or your family, it is essential that safety decals are clearly visible, in good condition, and applied to the appropriate equipment.

OBSERVE SAFE OPERATING PRACTICES

Carefully read this manual and all safety decals on your equipment. Safety decals must be kept in good condition. Replace missing or damaged safety decals free of charge by contacting Sukup Manufacturing Co. by mail at PO Box 677, Sheffield, Iowa USA 50475; by phone at 641-892-4222; or by e-mail at info@sukup.com.

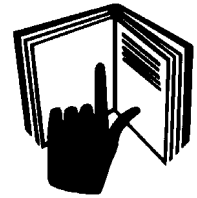

It is the responsibility of the owner/operator to know what specific requirements, precautions, and work hazards exist. It is also the responsibility of the owner/operator to inform anyone operating or working in the area of this equipment of the hazards and the safety precautions that need to be taken to avoid personal injury or death. **An example training register is printed in this section to assist in that process.**



Basic Safety Rules

1. Learn how to use controls and operate equipment.
2. Do not let anyone operate unit without thorough training of basic operating and safety procedures.

Always follow a proper lockout procedure.

3. Do not modify or redesign equipment without first obtaining written approval from Sukup Manufacturing Co. Unauthorized modifications to equipment may impair function and/or safety and affect machine life.
4. Periodically check all mechanical and electrical components. Keep unit in good working condition.
5. Handle equipment and parts with care. **Wear protective clothing** to avoid injury from sharp metal edges.
6. Wear Personal Protective Equipment (PPE) such as safety glasses, gloves, hardhat, steel-toe boots, ear protection and dust mask, in accordance with local and national requirements.

Keep unit well maintained according to procedures in the maintenance section of Operation Manual L13892.



WARNING: To avoid electrocution, all equipment must be properly wired and grounded according to electrical codes. Have unit wired by qualified electrician. Failure to heed this warning could result in death or serious injury.

IMPORTANT: Supporting electrical panels or combinations of electrical components supplied by the end user must be compliant with current editions of BS EN ISO 13849-1:2015.

Mains Isolater must be located outside of dryer. It must be easily accessible from ground level and must be lockable in off position. Mark clearly as to equipment it operates. See Mains Isolater decal placement information later in this section.

Always LOCK OUT main power switch (Mains Isolater) whenever equipment is not in use or when servicing unit. Check with voltage meter before servicing unit.

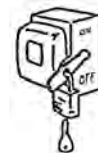

USE PROPER LOCKOUT PROCEDURES. Facility management needs to proactively train employees to ensure use of proper lockout procedures while working on dryer. Management also needs to inspect this unit for any covers or guards not in proper place. It is everyone's responsibility to report any missing grates, guards, equipment failures or failures to lock out. Make certain that no cover is removed unless power is locked out.

NOTE: Refer to the OSHA document 1910.147 App A for a typical minimum lockout procedure.



WARNING: Inspect ladder carefully before use. Never climb deteriorated, damaged, or improperly assembled ladder components. Maintain secure hand and foothold when climbing. Metal is slippery when wet. Never carry items while climbing. Failure to heed these warnings may cause serious injury or death. Use safety harness and safety line as required. Load limit on ladder is 300 lbs (136 kg).

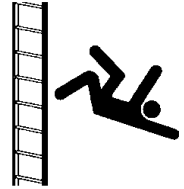

SAFETY QUESTIONS OR CONCERNS

Remember: Good housekeeping practices and correct safety procedures will help protect lives, jobs, property and profits. Keep area clean and place No Smoking Sign in immediate area of operation. Ensure quick access to an ABC (dry chemical) fire extinguisher.

Contact Sukup Manufacturing Co. with any specific safety needs regarding your tower dryer or its use!



WARNING: PREVENT EXPLOSION OR FIRE



- Carefully review operator's manual, including all safety instruction.
- Keep dryer clean inside and out, as fines may cause a fire.
- Check for gas leaks, (spray soapy solution on piping and joints.)
- NEVER start heater if you smell gas or hear a hissing sound.
- NEVER run heater with inspection door open.

Failure to heed these warnings may cause serious injury or death.

Please refer to Owner's Operation Manual for detailed instruction.

Initial gas hookups should only be performed by qualified gas service technicians in accordance with all applicable code requirements. In conditions of a threaded pipe train, a regulator must be installed on the gas tank and limit the pressure to 7 psi (0.5 bars). **IMPORTANT: End user must supply regulator, which must be in accordance with standard BS EN 88 or BS EN 334.**



WARNING: KEEP CLEAR OF ALL MOVING PARTS

Keep people (ESPECIALLY YOUTH) away from equipment, particularly during operation. Keep away from all moving parts. Entanglement can cause serious injury or death. Keep fan screen guards and all shields in place and in good working condition. Replacement screen guards and shields are available from Sukup Manufacturing Co. at no charge.

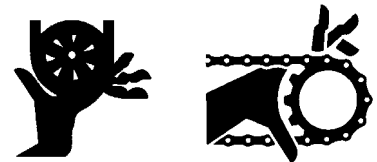

Failure to follow the above precautions may cause serious injury or death.

EMERGENCIES - KNOW WHAT TO DO

Have telephone numbers and written directions to your location near your telephone in the event of emergency. A place to record information is provided here.

Emergency Information
Ambulance: _____
Fire: _____
Address of work site: _____
Directions to your location: _____

Tower Dryer Safety Decals

To prevent death or serious injury to all persons involved in operation of this equipment, it is essential that these safety decals be mounted on dryer. Check that all are in place according to the decal placement drawing and are legible when dryer is installed.

IMPORTANT!! If suggested locations are not clearly visible, place safety decals in a more suitable area. Never cover up existing safety decals.

Make sure location for decal is free from grease, oil and dirt. Remove backing from decal and place in proper position. Replace missing or damaged safety decals or shields free of charge by contacting Sukup Manufacturing Co., by mail at PO Box 677, Sheffield, Iowa 50475 USA; by phone at 641-892-4222; or by e-mail at info@sukup.com. Please specify computer number when ordering.

1. **Decal L0164 - WARNING:** Ladder safety – falling from heights hazard. Overall precautions for ladder safety. **Load limit is 300 lbs (136 kg).**

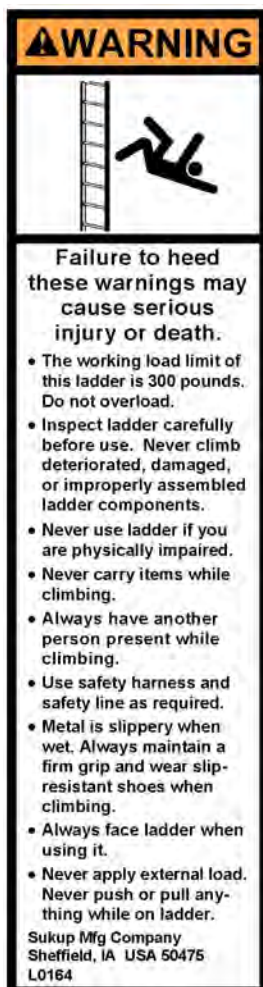

2. **Decal L0258A - DANGER:** Do not enter this bin! Keep clear of all augers.



3. **Decal L0520 - CAUTION:** Failure to keep unit clean may cause fire and serious injury or death.



4. **Decal L0237 - DANGER:** Door interlock switch. To prevent serious injury or death.



5. **Decal L0165 - WARNING:** Disconnect Electricity; Bleed gas; etc.



6. **Decal L0284 - WARNING:** Keep away from all moving parts.



8. **Decal L01135 - WARNING:** Avoid platform collapse. Do not exceed 500 lbs. (227 kg) maximum load.



7. **Decal L0281 - WARNING:** To avoid serious injury or death.



Tower Dryer Decal Placement

WARNING

Failure to heed these warnings may cause serious injury or death.

- The working load limit of this ladder is 300 pounds. Do not overload.
- Inspect ladder carefully before use. Never climb deteriorated, damaged, or improperly assembled ladder components.
- Never use ladder if you are physically impaired.
- Never carry items while climbing.
- Always have another person present while climbing.
- Use safety harness and safety line as required.
- Metal is slippery when wet. Always maintain a firm grip and wear slip-resistant shoes when climbing.
- Always face ladder when using it.
- Never apply external load. Never push or pull anything while on ladder.

Sukup Mfg Company
Sheffield, IA USA 50475
L0164

WARNING

Platform collapse can cause serious injury or death.

- Do not exceed 500 lbs. maximum load.

L01135

WARNING

Before operating:
Carefully review operator manual. Check for gas leaks.

- Keep all guards and screens in place.
- Never use fan or heater with unapproved dust bags.
- Never operate heater without all flow heaters ready to be mechanically interlocked with fan to prevent a fire.

Failure to heed these warnings may cause serious injury or death.

L0165

WARNING

TO PREVENT SERIOUS INJURY OR DEATH
Lock out all power and have another person present before entering!
Door interlock switch is designed to shut off power to system if door is opened completely. For the safety of you, your family and workers, make sure that this switch has been installed and working properly (see owner's manual).

- NEVER disconnect key from chain or chain from door.
- DO NOT pull door open to disconnect switch. ALWAYS remove key manually.
- NEVER use key to bypass when someone is inside.
- INSTRUCT users on the safe use of the equipment.
- NEVER DEFEAT THE PURPOSE OF THIS SWITCH. Any foot can bypass a safety switch, don't be fool!

Replacement safety shields and decals are available free of charge.

L0237

WARNING

TO AVOID SERIOUS INJURY OR DEATH:

- Read operator's manual before operating & follow all precautions.
- Keep shields and decals in place.
- Keep clear of all moving parts.
- Allow no children or unqualified persons to operate equipment.
- Know how to shut off power quickly.
- Keep people (especially children) away from unit at all times.
- Lock out all power and have another person present when servicing unit.

Replacement safety shields and decals are available free of charge.

L0281

CAUTION

KEEP DRYER CLEAN!

- Do not allow fines to accumulate inside or outside dryer.
- Clean daily.
- Open lower slide gate at rear to blow fines out of dryer (see manual for cleaning instructions).
- Protect eyes from blown material.

Failure to keep unit clean may cause a fire and serious injury or death.

L0520

DANGER

Rotating flighting will kill or dismember!
Falling material will trap and suffocate.
Crushed material will collapse and suffocate.

DO NOT ENTER this bin!
Keep clear of all augers.

If you must enter the bin:

- Shut off and lock out all power.
- Use a safety harness and safety line.
- Station another person outside the bin.
- Avoid the center of the bin.
- Wear proper breathing equipment or respirator.
- Follow applicable safety regulations.

Failure to heed these warnings will result in serious injury or death.

L0258A

WARNING

KEEP AWAY FROM ALL MOVING PARTS

Keep all shields in place. Lock out all power before servicing.

FAILURE TO DO SO MAY CAUSE SERIOUS INJURY OR DEATH

L0284

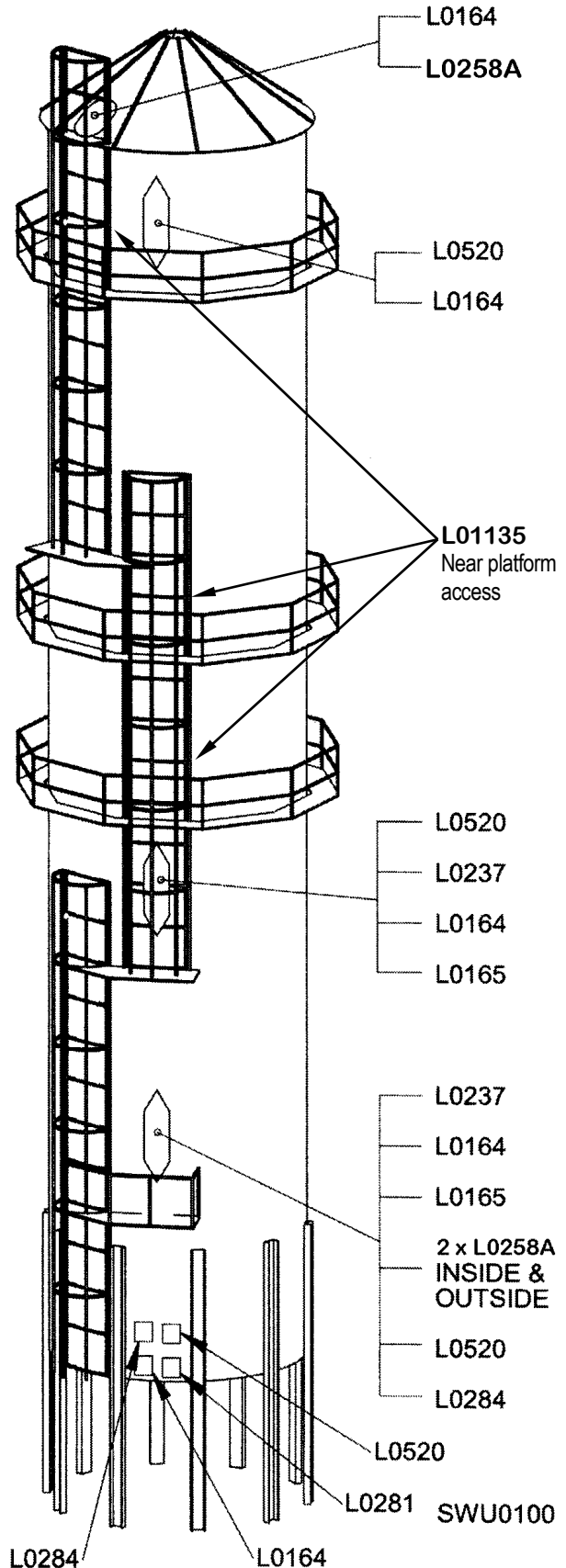
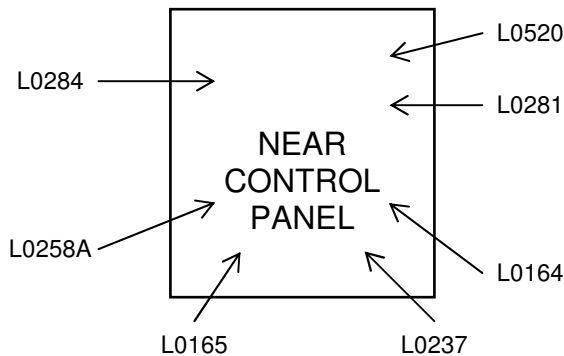

TOWER DRYER EU SAFETY LABELS

To prevent serious injury or death to you or your family, it is essential that these safety decals be mounted on your dryer.

Make sure location for decal is free from grease, oil and dirt. Remove backing from decal and place in proper position. Replace missing or damaged safety decals or shields free of charge by contacting Sukup Manufacturing Co. by mail at PO Box 677, Sheffield, Iowa 50475; by phone at 641-892-4222; or by e-mail at info@sukup.com. Please specify computer number.



L5100 Sukup Manufacturing Co Sheffield, IA USA

Label #L5100 – Place inside power box of dryer and on dryer where electrical precautions are needed.



L5101



Sukup Manufacturing Company Sheffield, IA USA

Label #L5101 – Place near power disconnect of dryer.



L5102



Sukup Manufacturing Company Sheffield, IA USA

Label #L5102 – Place near main power source of dryer.



L5103



Sukup Manufacturing Company Sheffield, IA USA

Label #L5103 – Place near main power source of dryer.



L5104

Sukup Manufacturing Co Sheffield, IA USA

Label #L5104 - Place at dryer access door (entrance to plenum).



L5105

Sukup Manufacturing Co Sheffield, IA USA

Label #L5105 – Place at dryer access door (entrance to plenum).



L5106



Sukup Manufacturing Company Sheffield, IA USA

Label #L5106 – Place near shut off to power source.



Label #L5107 – Place near main power shut off.



Label #L5109 – Place near main power panel.



Label #L5112 – Place near main power panel.



Label #L5113 – Place near main power panel.



Label #L5114 – Place near main power panel.

Risk reduction for servicing dryer

IMPORTANT: Conditions inside dryer plenum may vary greatly from the ambient conditions.

Please follow the safety guidelines before entering the plenum:

- Appoint a responsible individual to oversee the task and remain outside the dryer while servicing.
- Ensure the dryer is isolated, and all fuel and power is disabled to the unit.
- Operator is in good physical condition and at low risk of medical problems such as asthma and cardiac problems.
- Unit is empty of grain; avoid entry when unit is full.
- Do not close doors while inside the unit, to ensure proper airflow and vent toxic gasses.
- Have immediate and close access to a lifting device, which can reach the dryer platforms in the event of emergency.
- Have adequate tools on hand for quick removal of the ladder and cage in the event of an emergency.
- Carry a communication device to use in the event of an emergency and ensure proper signal is available (mobile phone with adequate signal).
- Wear personal protective equipment such as safety glasses, gloves, dust mask, steel-toe boots, ear protectors, safety harness, and hardhat, in accordance with local and national requirements.
- Consider additional risks when performing maintenance that includes cutting or welding (fire, fumes and dust). Ensure quick access to an ABC (dry chemical) fire extinguisher.
- Assess the climatic conditions: If the weather is undesirable (icy platforms, extreme heat) reduce risk by servicing when the climate improves.

Maintenance and inspection activities

- Use lifting device with safety cage to access top sections outside of dryer.
- Any access activities should be limited to allow for available space on platform. Make other arrangements for larger components.
- Do not exceed 500 lbs (227 kg) maximum load on platforms.
- Due to the infrequent operation of the rear access door interlock, the requirement is to perform a check at the start of the season to confirm the dryer does not start with the interlock disengaged.



In the event of minor injury (minor cuts and scrapes):

- Ensure a first aid kit is available on site and workers are trained in first aid to treat minor injury.
- Avoid first aid on the platforms due to low available workspace and height.
- Contact emergency services if the injury prevents descending from the dryer platforms.

In the event of serious injury (loss of consciousness or serious cut):

- Contact emergency services immediately.
- In the event of rescue from inside the plenum the ladder may hinder rescue. **The ladder and cage may be removed by cutting or unbolting the bracing brackets from the unit.**

Potential for Explosive Atmosphere



II (3) D

- II Identifies the area as Group 2
- (3) Identifies the area as Category 3
- D Identifies the area as having the potential for generating a dust explosion

Tower Dryer Specifications (EU)

Dryer Dimensions

Model	Grain Column mm / (in)	Tower Diameter mm / (ft, in)	Overall Height mm / (ft)
U1212	324 mm (12.75")	3,658 mm (12'0")	15,850 mm (52')
U1512	324 mm (12.75")	3,658 mm (12'0")	17,983 mm (59')
U1812	324 mm (12.75")	3,658 mm (12'0")	21,031 mm (69')
U2012	324 mm (12.75")	3,658 mm (12'0")	23,165 mm (76')
U2412	324 mm (12.75")	3,658 mm (12'0")	26,213 mm (86')
U2518	324 mm (12.75")	5,486 mm (18'0")	20,117 mm (66')
U3018	324 mm (12.75")	5,486 mm (18'0")	23,165 mm (76')
U3518	324 mm (12.75")	5,486 mm (18'0")	26,213 mm (86')
U4018	324 mm (12.75")	5,486 mm (18'0")	29,261 mm (96')
U4718	324 mm (12.75")	5,486 mm (18'0")	33,223 mm (109')
U5024	324 mm (12.75")	7,315 mm (24'0")	29,870 mm (98')
U6024	324 mm (12.75")	7,315 mm (24'0")	32,918 mm (108')
U7024	324 mm (12.75")	7,315 mm (24'0")	35,966 mm (118')

Dryer Mass

Model	Mass Empty kg / (lbs)	Mass Full kg / (lbs)
U1212	14,515 (32,000)	54,930 (121,100)
U1512	15,422 (34,000)	61,171 (134,860)
U1812	16,329 (36,000)	70,052 (154,440)
U2012	17,055 (37,600)	76,112 (167,800)
U2412	18,144 (40,000)	85,039 (187,480)
U2518	22,679 (50,000)	104,598 (230,600)
U3018	27,215 (60,000)	121,517 (267,900)
U3518	30,073 (66,300)	136,758 (301,500)
U4018	34,019 (75,000)	153,006 (337,320)
U4718	36,287 (80,000)	171,875 (378,920)
U5024	45,359(100,000)	226,615(499,600)
U6024	49,895(110,000)	242,445(534,500)
U7024	54,431(120,000)	258,003(568,800)

Burner Capacity

Model	Burner Capacity (BTU x 1000)/hr	Burner Capacity (KJ x 1000)/hr	Drying CFM	Drying CMS
U1212	13,457	14,198	62,300	29.4
U1512	16,805	17,730	77,800	36.7
U1812	18,490	19,508	85,600	40.4
U2012	20,434	21,559	94,600	44.6
U2412	23,825	25,137	110,300	52.1
U2518	27,767	29,296	128,550	60.7
U3018	32,011	33,773	148,200	69.9
U3518	37,649	39,722	174,300	82.3
U4018	44,582	47,036	206,400	97.4
U4718	48,859	51,549	226,200	106.8
U5024	59,422	62,694	275,100	129.8
U6024	63,958	67,479	296,100	139.7
U7024	74,196	78,281	343,500	162.1

Tower Dryer Specifications (continued)

Gas Consumption

Model	Max BTU/hr	Max kJ/hr	LPG L(gal)/hr	NG m ³ (ft ³)/hr
U1212	13,457,000	14,197,887	553.7(146.3)	381.1(13,457.0)
U1512	16,805,000	17,730,214	691.5(182.7)	475.9(16,805.0)
U1812	18,490,000	19,507,983	760.8(201.0)	523.6(18,490.0)
U2012	20,434,000	21,559,011	840.8(222.1)	578.6(20,434.0)
U2412	23,825,000	25,136,706	980.3(259.0)	674.6(23,825.0)
U2518	27,767,000	29,295,736	1,142.5(301.8)	786.3(27,767.0)
U3018	32,011,000	33,773,393	1,317.1(347.9)	906.5(32,011.0)
U3518	37,649,000	39,721,798	1,549.1(409.2)	1,066.1(37,649.0)
U4018	44,582,000	47,036,500	1,834.4(484.6)	1,262.4(44,582.0)
U4718	48,859,000	51,548,974	2,010.3(531.1)	1,383.5(48,859.0)
U5024	59,422,000	62,693,529	2,444.7(645.9)	1,682.6(59,422.0)
U6024	63,958,000	67,479,262	2,631.3(695.2)	1,811.1(63,958.0)
U7024	74,196,000	78,280,924	3,052.5(806.5)	2,101.0(74,196.0)

Heat capacity of gas used:

Natural Gas: 1,000 btu/ft³, 43,000 kJ/m³

LPG: 2,500 btu/ft³, 101,000 kJ/m³

Gas pressure supplied to the dryer must be 7psi (0.5 bar), provided by local utility. End user must supply regulator, which must be in accordance with standard BS EN 88 or BS EN 334.

Many factors, such as grain variety, maturity levels, grain cleanliness, weather conditions and operation-management, can affect the performance of your tower dryer and results may vary. This information is calculated and is not a guarantee of product specifications or performance and should only be used to estimate tower dryer performance under normal operating conditions.

Electrical Load Requirements

Note: A Service-Rated, Fused Disconnect needs to be installed ahead of the Dryer power distribution box. This disconnect is not included with the dryer and should be installed by a qualified electrician in accordance with local and national standards.

Caution: The only device connected to this disconnect should be your Grain Dryer.

Note: All current specifications include the Service Factor.

The following charts provide information for the electrician wiring the Grain Dryer. It is recommended that you contact your local Power Company and have a representative inspect the installation to see that your wiring is compatible with their system, and that sufficient power is supplied to your dryer.

Standard electrical safety practices and codes should be used. **IMPORTANT: Any supporting electrical panels or combinations of electrical components supplied by the end user must be compliant with current editions of BS EN ISO 13849-1:2015.**

All electrical work should be completed by a qualified electrician.

Dryer Electrical Specifications

SINGLE FAN MODEL

U1212 Tower Dryer 400 Volts 3PH Main Switch = 250 Amps

	Fan #1	Unload	Total Amp Load
Motor	45 kw 90 Amps	1.1 kw 3.0 Amps	93

SINGLE FAN MODEL

U1812 Tower Dryer 400 Volts 3PH Main Switch = 250 Amps

	Fan #1	Unload	Total Amp Load
Motor	55 kw 100 Amps	1.1 kw 3.0 Amps	103

SINGLE FAN MODEL

U2412 Tower Dryer 400 Volts 3PH Main Switch = 250 Amps

	Fan #1	Unload	Total Amp Load
Motor	75 kw 134 Amps	1.1 kw 3.0 Amps	137

THREE FAN MODEL

U3518 Tower Dryer 400 Volts 3PH Main Switch = 400 Amps

	Fan #1	Fan #2	Fan #3	Unload	Total Amp Load
Motor	45 kw 90 Amps	45 kw 90 Amps	45 kw 90 Amps	1.5 kw 3.4 Amps	273.4

Therm-O-Disc High Temperature Limit Switch

GENERAL ELECTRICAL RATINGS

The 10H series of controls has been rated by major agencies throughout the world. The agency ratings can be used as a guide when evaluating specific applications. However, the mechanical, electrical, thermal and environmental conditions to which a control may be exposed in an application may differ significantly from agency test conditions. Therefore, the user must not rely solely on agency ratings, but must perform adequate testing of the product to confirm that the control selected will operate as intended in the user's application.

Thermostat Type	Maximum Capillary Temperature	Maximum Switchcase Temperature	Resistive Amperes	Volts AC	Cycles	Agency Recognition
10H11	350°F	221°F	25	120/240/277	100,000	UL Guide MBPR2, File MH-5304
10H14	350°F	221°F	25	120/240/277	6,000	CSA File LR19988

NOTE: For complete and current ratings, please consult Therm-O-Disc online at www.thermodisc.com

U1212, U1812, U2412 Tower Dryer Control Box

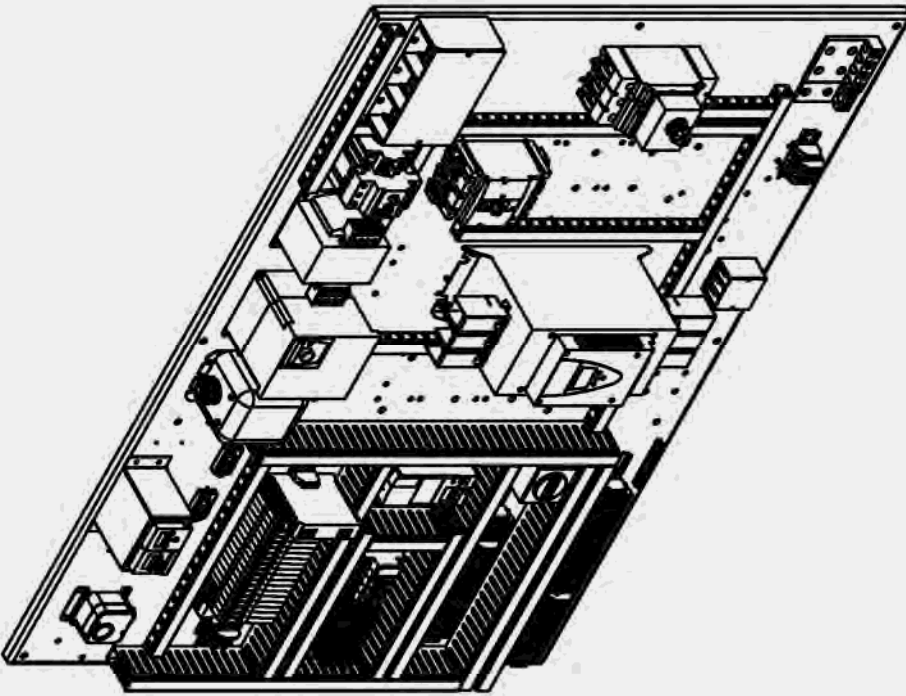

07/07/2014
TOWER DRYER CONTROL BOX
COMP. ELEC. 380V. 1x50/60 HP

J8704	SLICE I/O,AI2/SF-ME,PHOENIX	3
J8705	SLICE I/O,AO2ME,PHOENIX	1
J8706	SUPPLY,POWER,TRIO,PHOENIX	1
J8772	RELAY, 24VDC, PT PHOENIX #2900299 CESCO #801746	22
J8774	RELAY, 110VAC, PHOENIX PT PHOENIX #2900304	4
T16530	BRACKET, HOURMETER, PORT DRYER	1
T80334	BRACKET, AIR SWITCH, DUNGS CE DRYER	1
U12265	PLATE, INT. MOUNTING, 5'X4', 2011 TOWER DRYER	1
U12386	MOUNT, DISPLAY, TWR DRYR PWR BOX	1
U17018	TRANSMITTER, RTD, GRAY, 100 OHM TOWER	1
U17028	TRANSMITTER, RTD, BLACK, 1000 OHM TOWER	1

Model
U2412
 Uses
 J5234
 J52411

Model
U1212
 Uses
 J6868
U1812
 Uses
 J6869
U2412
 Uses
 J6870

ITEM #	PART #	DESCRIPTION	QTY.
1	J4053	LUG, CONTACTOR, 350MCM, CULVER, TA350	6
2	J40471	LUG, COVER, FOR AT522, CULVER LA9F702, 6/PK	1
3	J4051	LUG, GROUND, 4 HOLE, 250MCM CULVER, 4250L4	1
4	J4052	LUG, GROUND, 2 HOLE, 250MCM CULVER, NSI, N/A	1
5	J47412	RACEWAY, 1X3, CULVER, PC1030L5	8
6	J4766	HOURMETER, 115V, 60HZ, #711-0150 ALLIED 620-4016	1
7	J47902	BAR, GROUND, 9 HOLE ALUM., PK9GTA, CULVER	1
8	J48189	BREAKER, CIRCUIT, 1PH, 2POLE, 480V	2
9	J48190	BREAKER, CIRCUIT, 1PH, 1/2A, 250V	1
10	J48191	BREAKER, CIRCUIT, 1PH, 3AMP, 250V	2
11	J48194	BREAKER, CIRCUIT, 1PH, 7AMP, 250V	1
12	J48951	TRANSFORMER, 380V-120V, 1 KVA, CULVER	1
13	J52121	SWITCH, MAIN, 250A, 3PH (JGL36000S25)	1
14	J5233	STARTER, PROTECTOR, 2.5-4 AMPS, (GV2ME08)	1
15	J5241	STARTER, PROTECTOR, 90-150 AMPS	1
16	J52412	LUG, BOX, FOR J52411, (GV7AC022) 3 PER PK	2
17	J52413	SHUNT, TRIP, FOR GV7 SERIES SP GV7AS107 110V	2
18	J5263	AUX CONTACT (GV7-AE11)	1
19	J5614	RELAY, TIMER, RE11RAMU ON DELAY, 24-230V	1
20	J5710	TRANSFORMER, IGNITION, A06-SA6	1
21	J57134	MODULE, PROG, PME73, 840A1 FOR LME 73, SIEMENS	1
22	J57136	CONTROL, GAS, BURNER LME73, 000A1, SIEMENS	1
23	J5868	SWITCH, AIR, DUNGS, LGW10 A2	1
24	J6690	BLOCK, DISTRIBUTION, 3PH, 2/0	1
25	J6691	COVER, FINGER SAFE, FOR J6690, CULVER, 9080LB23	1
26	J6696	COVER, ASSY, 3P9080LB51 M.C. GLASS	1
27	J6697	BLOCK, POWER DIST., STACK, LBA365208	1
28	J6706	COVER ASSY, 9070FSC-2	2
29	J6718	RAIL, DIN, 1111, 013 (2MPC) 35MMX7.5MM PLTD	80
30	J67401	RACEWAY, 1" SLA1X1G	11
31	J67411	COVER, RACEWAY, 1", TC1G4	19
32	J67421	TERMINAL FEED THRU, 70 AMP (011 512 017)	4
33	J6754	STOP, DIN END	29
34	J67697	MECHANISM, IEC OPER, 250AMP, SOD S29338, MECH ONLY	1
35	J67801	DISPLAY, REMOTE, VFD, FOR ATV312	1
36	J67803	DISPLAY, REMOT, SFT ST, VW3GG2101	1
37	J6851	DRIVE UNIT AC, 3HP 460V 3P, (ATV31HU22N4)	1
38	J6868	STRTR, MTR, SFTST, 110A, ATS22C11S6U, 2V, 30HP, 6V, 100HP	1
39	J6904	TERMINAL, PARTITION, PHOENIX	6
40	J6905	BRIDGE, TERM, 2-TERM, PHOENIX, CRESCENT	6
41	J6907	BRIDGE, TERM, 4-TERM, PHOENIX, CRESCENT	4
42	J6915	TERMINAL, PIT 2.5 TWIN, PHOENIX	128
43	J6916	TERMINAL, COVER, PIT 2.5, PHOENIX	14
44	J6920	TERMINAL, GROUND, PHOENIX	2
45	J8700	PLC, PHOENIX, ILC150	1
46	J8701	SLICE I/O, DI4ME, PHOENIX	2
47	J8702	SLICE I/O, DI16ME, PHOENIX	1
48	J8703	SLICE I/O, DO4ME, PHOENIX	1
49	J87031	SLICE, I/O, DO16ME, PHOENIX	1

U3518 Tower Dryer Control Box

ITEM NO.	PART NUMBER	DESCRIPTION	QTY.
1	J4046	LUG CONTACTOR DZ2EHT FOR J6078(TOWER)	18
2	J4047	LUG COVER FOR AT522 CULVER, LA9F702	18
3	J4051	LUG GROUND 4 HOLE, 250 MCM CULVER, 4250U 4	1
4	J4052	LUG GROUND 2 HOLE, 250 MCM CULVER, NSL 2250U 2 RACEWAY 1X3 PANEL CHANNEL, CULVER HAHN, PC1030U S	1
5	J47412		8
6	J4766	HOURMETER, 115V, 60HZ	1
7	J47902	GROUND BAR 9 HOLE ALUM.(PK9G1A)	1
8	J48189	BREAKER CIRCUIT 1 PH 2 POLE 480V, 3 AMP	1
9	J48190	BREAKER CIRCUIT 1PH 250V 0.5 AMP	1
10	J48191	BREAKER CIRCUIT 1PH 250V 3 AMP	2
11	J48194	BREAKER CIRCUIT 1PH 250V 7 AMP	1
12	J48951	TRANSFORMER, 380V-200V 1KVA, CULVER	1
13	J52143	SWITCH, MAIN, 600 AMP, 3 POLE; MHL360006M, DUL360005S0	1
14	J5236	STARTER PROTECTOR, 6-10 AMPS,(GV2ME14)	1
15	J5241	STARTER PROTECTOR, 90- 150 AMP	3
16	J52412	LUG BOX FOR J5241	18
17	J52413	SHUNT TRIP 110 V TOWER	1
18	J5263	AUX CONTACT (GV7-AE11)	3
19	J5614	RELAY TIMER RE11RAMU	1
20	J5710	TRANSFORMER IGNITION A06-SA6 MODULE, PROGRAMMING PME73 840A, FOR LIME	1
21	J57134	73.SIEMENS	1
22	J57136	CONTROL GAS BURNTERMVZ3 000A, SIEMENS	1
23	J5860	AIR SWITCH, B1-IC-31, MOD RT 4	2
24	J5868	SWITCH AIR DUNGS LGW1042	1
25	J6690	BLOCK DISTRIBUTION 3PH 2/0	3
26	J6691	COVER FINGER SAFE FOR J 6690, CULVER 9080U B23	3
27	J6696	COVER ASSY 3P9080U51 M.C. GLASS, FOR J6697	1
28	J6697	BLOCK, POWER DISTRIBUTION STACK	1
29	J6706	COVER ASSY	2
30	J6718	RAIL DIN, 8501N113	8
31	J6740	RACEWAY 1.5"	5
32	J67401	RACEWAY 1"	10
33	J6741	COVER 1.5" RACEWAY	5
34	J67411	COVER 1" RACEWAY	18
35	J67421	TERMINAL FEED THRU, 70 AMP	4
36	J6754	STOP DIAL END	17
37	J67688	MECHANISM IEC OPERATOR 400 AMP, 600 AMP	1
38	J67801	DISPLAY TERMINAL REMOTE, VFD	1
39	J67803	DISPLAY TERMINAL REMOTE, SOFT START	3
40	J6881	DRIVE UNIT, AC 3HP 480V 3PH	1
41	J6889	STARTER MOTOR SOFT START, 140A AT522C14S6U	3
42	J6904	TERMINAL PARTITION, PHOENIX	4
43	J6905	BRIDGE TERM. 2-TERM. PHOENIX CRESCENT ELECTRIC	6
44	J6907	BRIDGE TERM. 4-TERM. PHOENIX CRESCENT ELECTRIC	3
45	J6915	TERMINAL TWIN PHOENIX	134
46	J6916	TERMINAL COVER TWIN PHOENIX	9
47	J6920	TERMINAL GROUND PHOENIX	1
48	J6700	SLICE 1C150 PHOENIX	1
49	J6701	SLICE 1D14ME PHOENIX	2
50	J6702	SLICE 1D16ME PHOENIX	1
51	J6703	SLICE 1D24ME PHOENIX	1
52	J67031	SLICE 1D16ME PHOENIX	1
53	J6704	SLICE 1D14ME PHOENIX	3
54	J6705	SLICE 1D20ME PHOENIX	1
55	J6706	POWER SUPPLY TRIO, PHOENIX	1
56	J6724	RELAY BASE SPRING CAGE DC-24V	22
57	J6726	RELAY BASE SPRING CAGE AC 110V	4
58	T16530	BRACKET HOURMETER PORT DRYER	1
59	T80334	BRKT AIR SWITCH DUNGS	1
60	U12386	MOUNT DISPLAY TWR DRYER	2
61	U12388	PLATE INTERIOR MOUNTING 5X5 SPLIT	1
62	U17018	TRANSMITTER, RTD, GRAY 100 OHM, TWR DRYER	1
63	U17026	TRANSMITTER, RTD, BLACK, 1000 OHM, TWR DRYER	1

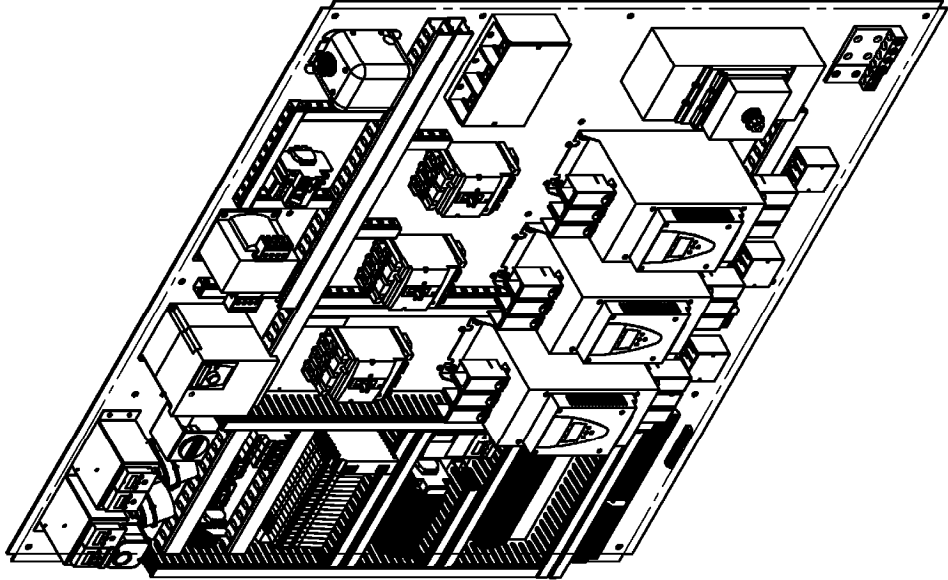

SUKUP MFG. CO.
SUKUP PARKWAY
SHEFFIELD, IA. 50475

TOLERANCE UNLESS SPECIFIED .X = ± .050 XX = ± .010 .XXX = ± .005 FRAC = ± 1/32	DRAWN BY CSH	PART NO. U189986
DATE 7/2/2012	MATERIAL	
USED IN ASST FOR	TOWER DRYER CONTROL BOX	
DESCRIPTION	COMP, ELEC, 380V, 3x75 HP	
SHEET: 1 OF 3		

NOTICE: The information contained herein is a confidential disclosure. This material is property of Sukup Manufacturing Co., Sheffield, Iowa, USA and is not to be used in any way detrimental to Sukup's interest. Reproduction is prohibited.

REV.	DESCRIPTION OR ENG. ORDER #	DATE	BY
REVISIONS			

U3518 Tower Dryer Control Box

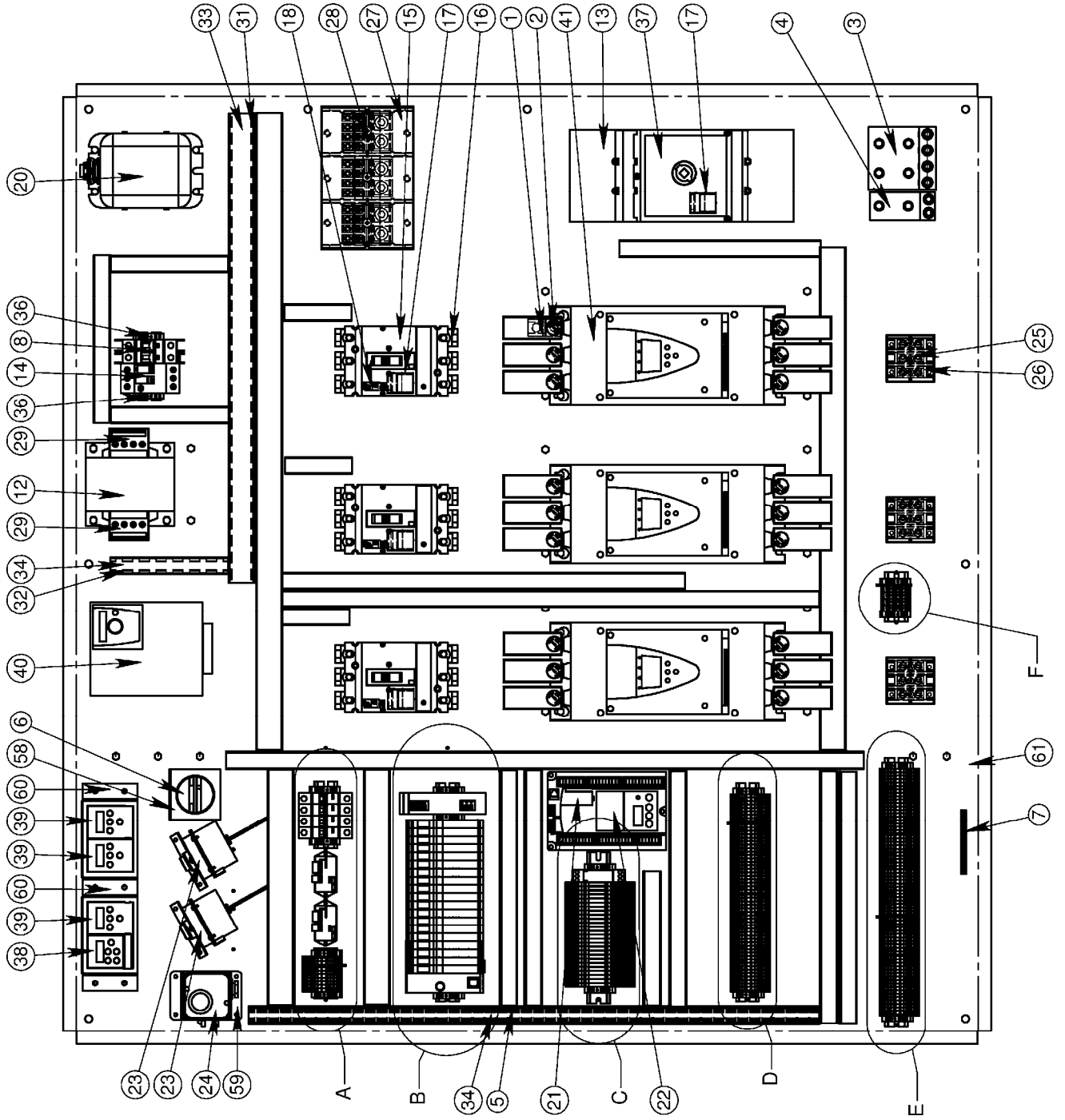

U3518 Tower Dryer Control Box

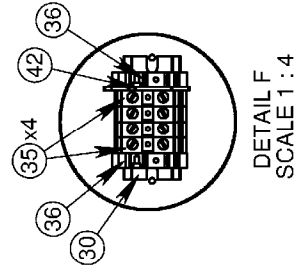
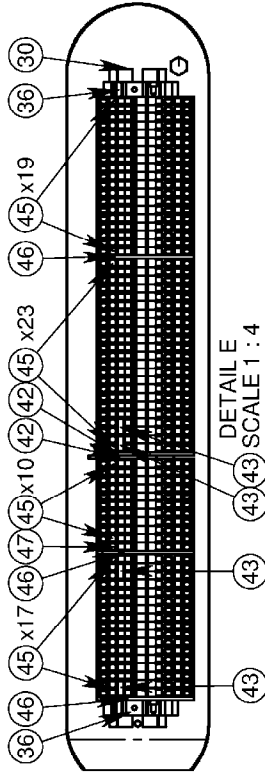
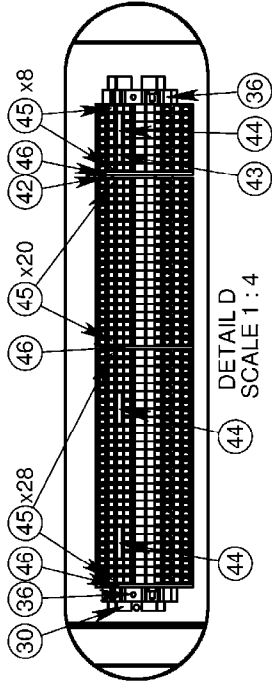
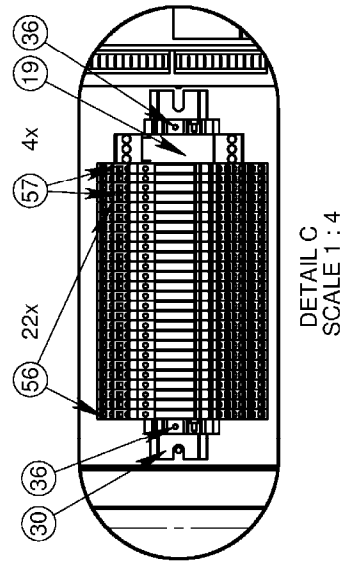
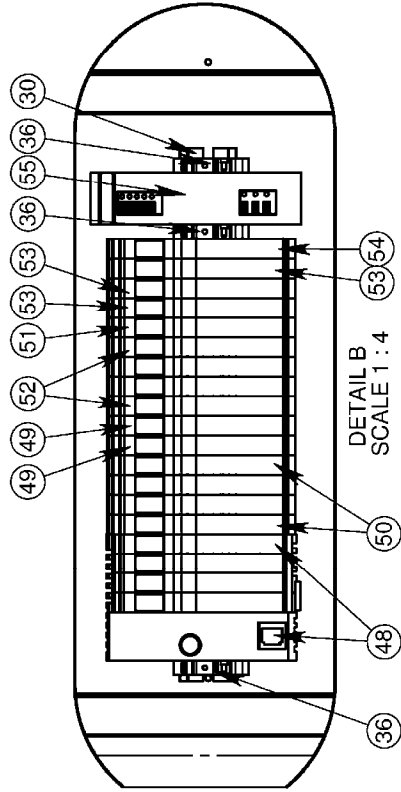
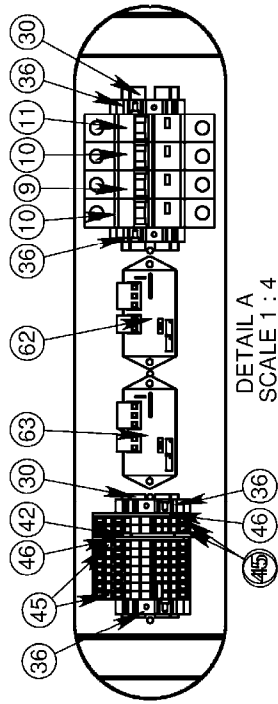

Training Register – Tower Grain Dryer

Training on operation of a Sukup Tower Dryer and related equipment is paramount to ensuring safe and successful use of the dryer.

This training register is to be used in conjunction with the general operation and maintenance instructions to emphasize the importance of safety. Use additional spaces for elements unique to your dryer.

NOTE: It is the owner’s responsibility to give adequate training to employees and to assess their ability to safely use the equipment.

Element	Date	Comments
Prior to start-up, inspect: - burner unit for blockage of ports or holes - wiring for loose connections or damage - belts for tension, cracks or wear - moisture sensor for buildup inside tube - fuel train, pipework, valves, filters for leaks - pipetrain drain valve for water; then close - rotor for obstruction - should turn freely		
Power shut off Fuel system shut off		
ATEX training Safe practice		
Action in event of emergency/fire		Use ABC (dry chemical) fire extinguisher
Alarms – what to do		
PPE (Personal Protective Equipment)		
Cleaning/maintenance and safe access to plenum - Isolate power to dryer; lock out		Follow maintenance procedures in operation manual
Entry into confined spaces Authorized personnel only Safe practice and access		Confined space entry training
Maintenance of the dryer - Problem solving - Isolate power to dryer; lock out - Authorized personnel only to work on gas train/electrical - Perform a check at start of each season to confirm dryer does not start with rear access door interlock disengaged.		Use lifting device with safety cage to access top sections outside of dryer.
Best practices for grain drying		Sunflower seeds and canola require a low temperature setting

LADDER PLACEMENT, 1212 TOWER DRYER

Illustration below shows ladder and cage locations referring to a flat Tower Dryer view

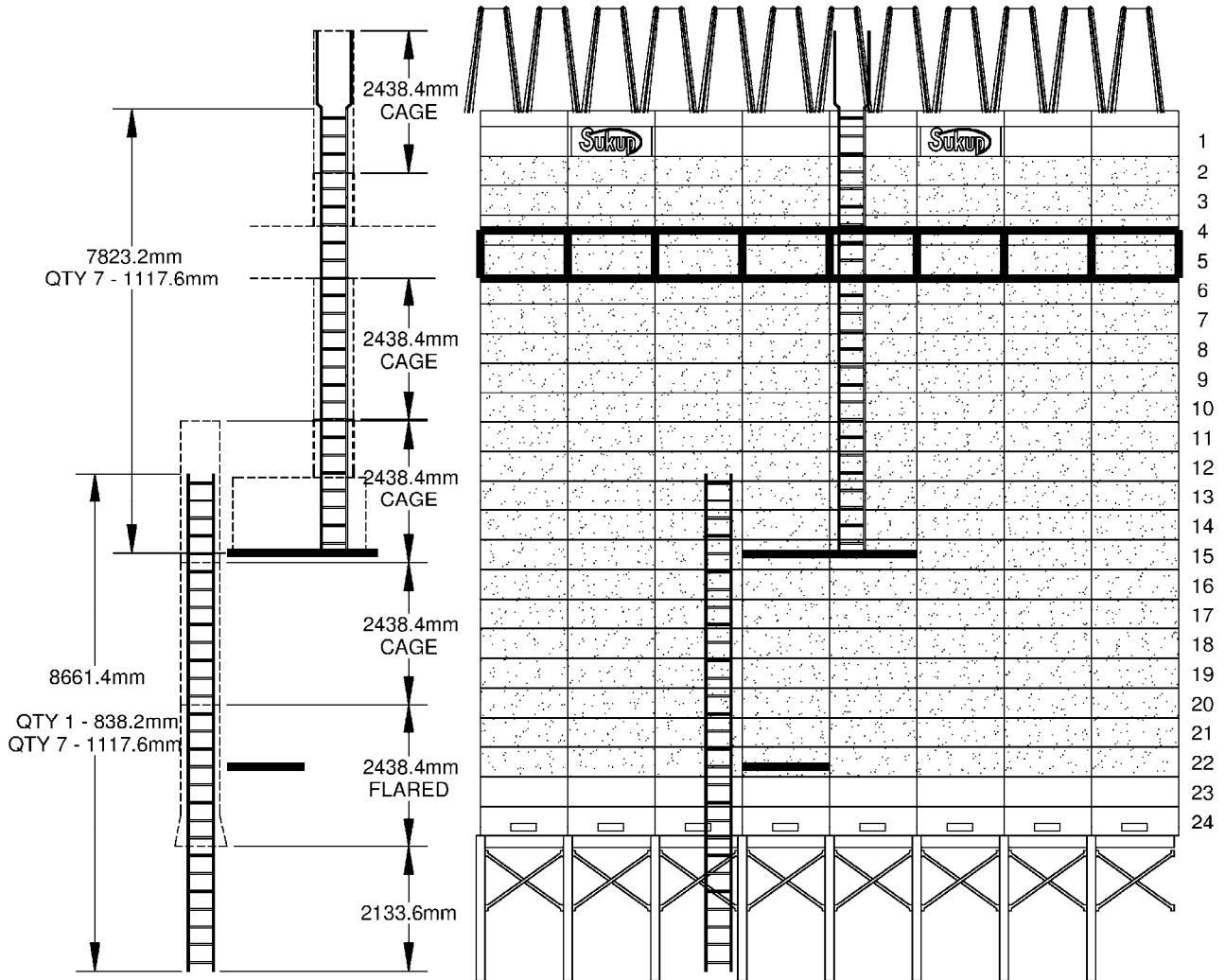

SWU1212EURO
05/09/2012 MCM

LADDER PLACEMENT, 1812 TOWER DRYER

Illustration below shows ladder and cage locations referring to a flat Tower Dryer view

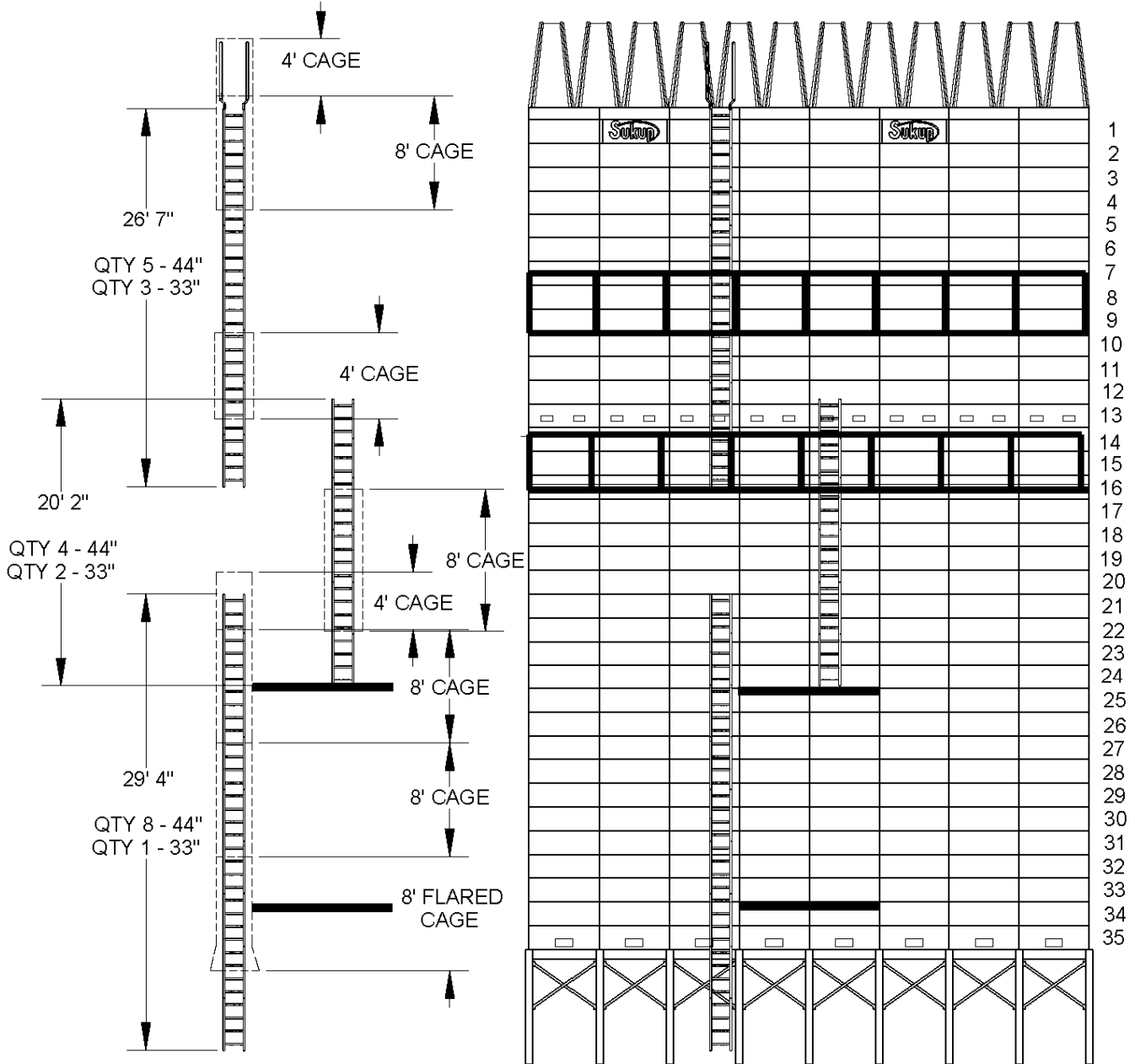

SWU1812
4/6/2011BAP

LADDER PLACEMENT, 2412 TOWER DRYER

Illustration below shows ladder and cage locations referring to a flat Tower Dryer view

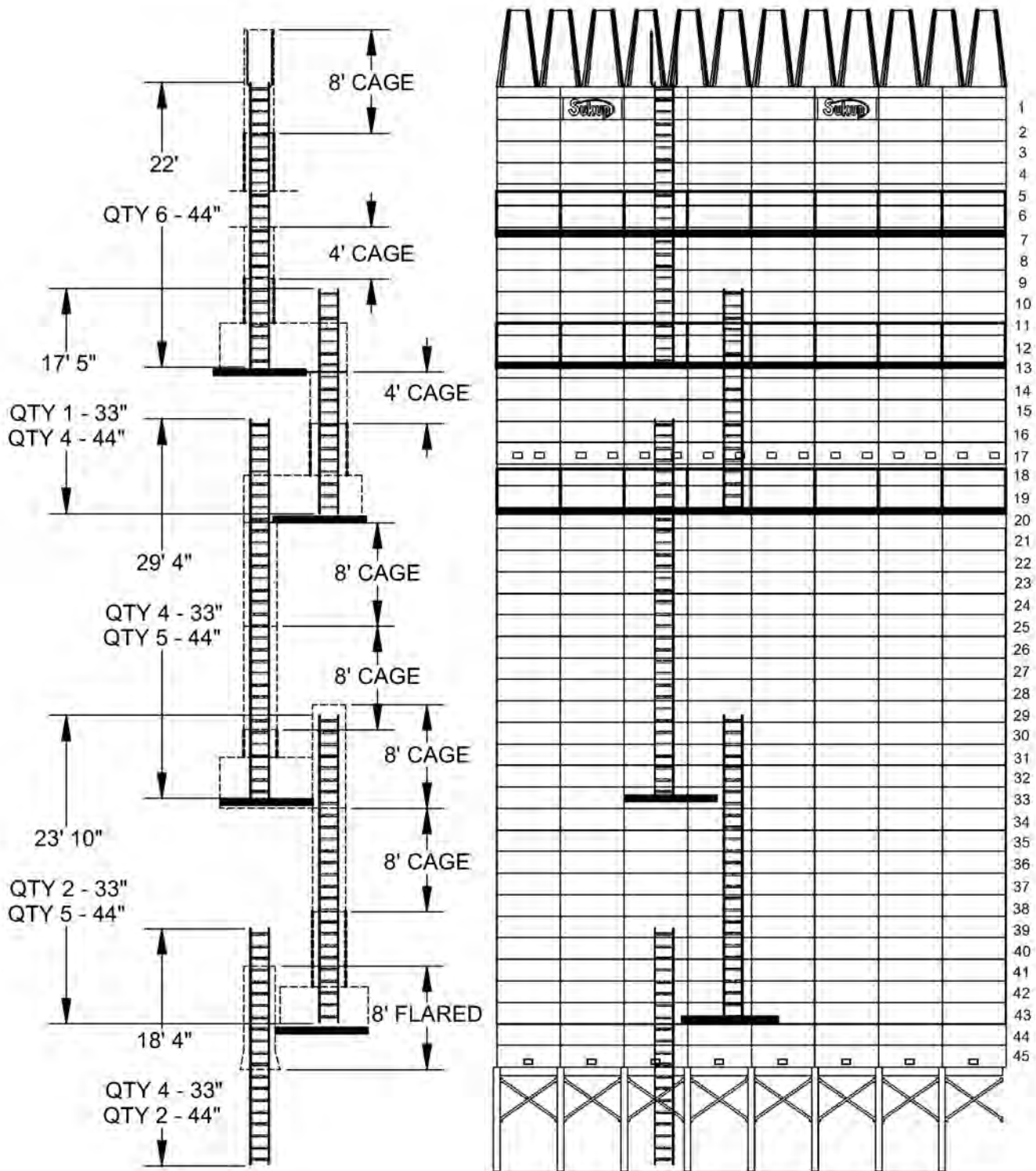

SWU2412
5/4/2011BAP

LADDER PLACEMENT, 3518 TOWER DRYER

Illustration below shows ladder and cage locations referring to a flat Tower Dryer view

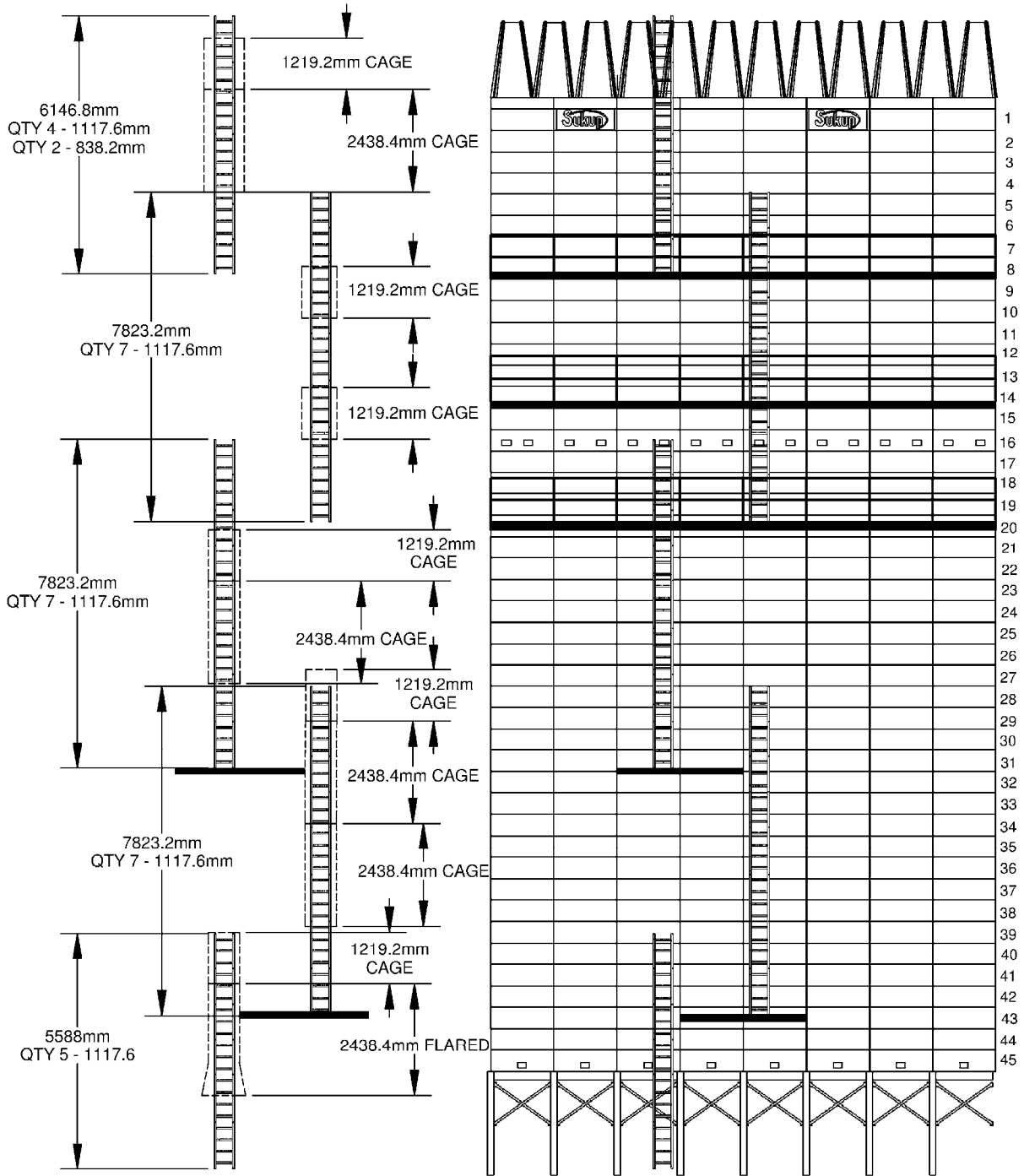

SWU3518EURO
05/09/2012MCM

Contact Information

Additional copies of this supplemental manual are available from Sukup at the address, phone number, or e-mail address shown below. Please indicate manual number L13892EU (Under Declaration of Incorporation) when requesting the EU Supplemental Manual for Tower Grain Dryer. This manual is a supplement to Tower Dryer Operation Manual L13892.



Sukup Manufacturing Co.

1555 255th Street, Box 677

Sheffield, Iowa USA 50475-0677

Phone: 641-892-4222 Fax: 641-892-4629

Website: www.sukup.com Email: info@sukup.com