



Channel - Lok™

HAWK CUT BIN FLOORS & SUPPORTS Installation & Owner's Manual MAJOR BIN DIAMETERS

15', 18', 21', 24', 27', 30', 33', 36',
42', 48', 54', 60', 72', 75', 78'

Sukup Manufacturing Co.

1555 255th Street, Box 677

Sheffield, Iowa, USA 50475-0677

Phone: 641-892-4222

Fax: 641-892-4629

Website: www.sukup.com

E-mail: info@sukup.com

IMPORTANT: This manual is for installation of **Hawk Cut Flooring** in bin diameters shown above. For installation manual for other type of Sukup flooring, see table below.

FLOORING TYPE	PLANK WIDTH	BIN MFR.	MANUAL #	Hawk Cut shown	
Heavy Duty Perforated	7-1/8"	Sukup	L1417HDB		
	7-1/8"	Other	L1418HDB		
Hawk Cut	7"	Sukup	L1417		
	7"	Other	L1418		

DATE	REVISION	PAGE
08/22/2025	Updated instructions for supporting Paddle Sweepway	27
10/18/2024	Added photo of Hawk Cut flooring	1
	Removed reference to discontinued square tube bridge supports; updated Fig. 13	17
	Removed reference to HD Perf. floor planks	18
	Updated instructions for use of Double Super Supports installation	20-25
	Added note on using HD Double Super Supports for bridging	27

INTRODUCTION

This product was carefully designed to give years of dependable service and was manufactured with the finest materials available. This manual includes information relating to safety and installation and should be thoroughly read prior to installation of Channel-Lok bin floor and supports. Due to the scope of projects involving material handling equipment and the wide variety of situations, this manual cannot cover all aspects. Qualified civil engineers and contractors should be relied upon for site design, layout and construction. This manual is to be used as a guideline only. The reliability, safety and good service life of this product depends to a very large extent on the care taken in installing and otherwise preparing this product for its intended use.

RECEIVING AND INSPECTION

Carefully inspect materials for damage as soon as they are received. Verify that quantities of parts or packages received correspond to quantities shown on packing slip. Report any damage or shortage to delivery carrier as soon as possible. Sukup Manufacturing Co.'s responsibility for damage to materials ended with acceptance by delivery carrier. Refer to bill of lading. Save all paperwork and documentation furnished with floor components.

NOTICE: Prior to installation, protect floor from weather.
Do not allow moisture to become trapped between any galvanized parts.

DISCLAIMER: Grain pressure can cause flooring to cup, especially in deeper grain (taller bins). Cupping does not constitute a floor failure, thus is not covered by Sukup Manufacturing Co. warranty.

NOTE: For instructions on installation of flush floor over aeration tunnel(s), see manual L14045, Flush Floor Aeration Installation & Owner's Manual.

TABLE OF CONTENTS

Limited Warranty-----	3
Safety-----	4
SuperWave Supports Installation Instructions-----	8
Z-Post Supports Installation Instructions-----	11
Super Supports Installation Instructions-----	14
Supporting Floor Over Unload System-----	17
Supporting Floor Planks at Splits-----	29
Installing Split Planks at Center Sump-----	30
Floor Plank Splicing-----	31
Flashing Installation-----	32
Floor Plank Layouts-----	33
Contact Information-----	70



Sukup Manufacturing Co.

PO Box 677 Sheffield, IA USA 50475

Phone: 641-892-4222 Fax: 641-892-4629

E-mail: Info@sukup.com Visit us at: www.sukup.com

GRAIN HANDLING & MATERIAL HANDLING LIMITED WARRANTY

SUKUP MANUFACTURING CO. (Sukup) warrants to original retail purchaser that within time limits set forth, new equipment shall be free from defects in material and workmanship. A part will not be considered defective if it substantially fulfills performance specifications, including, but not limited to, parts with cosmetic (appearance) issues that will not affect life of product. Should any part prove defective within warranty period, part will be replaced or repaired without charge F.O.B. Sukup Manufacturing Co., Sheffield, Iowa USA or Distribution Centers - Arcola, Illinois; Aurora, Nebraska; Cameron, Missouri; Defiance, Ohio; Jonesboro, Arkansas; Watertown, South Dakota. To claim warranty, a copy of original invoice is required.

THE FOREGOING LIMITED WARRANTY IS EXCLUSIVE AND IN LIEU OF ALL OTHER WARRANTIES OF MERCHANTABILITY, FITNESS FOR PARTICULAR PURPOSE AND OF ANY OTHER TYPE, WHETHER EXPRESS OR IMPLIED. Sukup neither assumes nor authorizes anyone to assume for it any other obligation or liability in connection with said part, and will not be liable for incidental or consequential damages. THE REMEDIES STATED HEREIN SHALL BE THE EXCLUSIVE REMEDIES AVAILABLE UNDER THIS LIMITED WARRANTY.

Sukup reserves the right to change specifications, add improvements or discontinue manufacture of any of its equipment without notice or obligation to purchasers of its equipment. This warranty gives you specific legal rights. You may also have other rights which vary according to state or province.

WARRANTY EXCLUSIONS - Labor, transportation, or any cost related to a service call is not provided by Sukup. This Limited Warranty does not apply to damage resulting from misuse, neglect, normal wear, accident or improper installation or maintenance. ITEMS NOT MANUFACTURED BY SUKUP (e.g. tires, belts, motors) ARE COVERED UNDER WARRANTIES OF THEIR RESPECTIVE MANUFACTURERS AND ARE EXCLUDED FROM COVERAGE UNDER THE SUKUP WARRANTY. Since the stirring down augers are so critical to the successful operation of the stirring machine, Sukup Manufacturing Co. will not warranty any machines unless they are equipped with Sukup down augers. SUKUP MANUFACTURING CO. MAKES NO WARRANTY, EXPRESS OR IMPLIED, WITH RESPECT TO DOWN AUGERS LONGER THAN 20', INCLUDING, WITHOUT LIMITATION, ANY WARRANTY OF MERCHANTABILITY AND WARRANTY OF FITNESS FOR A PARTICULAR PURPOSE.

Upon taking delivery of product, purchaser (dealer and/or end user) assumes responsibility for proper storage of all materials. Proper storage includes dry, temperature and humidity-controlled facilities, which eliminate the potential of moisture, including condensation, from causing white rust and/or corrosion of any sort. Warranty does not extend to defects, damage or cosmetic (appearance) issues caused by improper storage, handling or erection.

BASIC WARRANTY - All Sukup manufactured products are warranted for one year from date of purchase. Part(s) must be returned to Sukup within 30 days in event of failure.

EXTENDED STIRRING MACHINE WARRANTY - Sukup warrants stirring machines for two years from date of purchase.

EXTENDED STIRRING AUGER WARRANTY - Sukup warrants stirring down augers for two years from date of purchase. Must return top 18" of down auger to obtain credit.

EXTENDED FAN WARRANTY - Sukup warrants fans for two years from date of purchase.

EXTENDED HEATER CIRCUIT BOARD WARRANTY - Sukup warrants heater circuit boards for three years from date of purchase. Rebuilt circuit boards are warranted for one year from date of purchase.

EXTENDED MATERIAL HANDLING WARRANTY - Sukup warrants Material Handling equipment, excluding structural support systems, for two years from date of purchase.

REPLACEMENT PARTS WARRANTY PERIOD - Sukup warrants replacement parts (e.g. belts, sensors, rotating contacts, gearmotors, switches) purchased from Sukup for one (1) full drying season following purchase.

ELECTRIC MOTOR WARRANTY - Manufacturers of electric motors warranty them for at least 1 year from installation date or 2 years from motor manufacture date. Process for repairing or replacing motor depends on motor manufacturer and horsepower. Contact motor manufacturer for terms. If motor warranty is refused, use the following procedure: Have motor repair shop fill out the warranty report form as if they were providing warranty service. State on report reason for refusal. Send report, motor nameplate, and proof of purchase date (invoice from Sukup and invoice for your customer) to Sukup. Sukup will attempt to obtain warranty from motor manufacturer. Any credit obtained will be passed on. Warranty may also be obtained by returning motor to Sukup Manufacturing Co. or Distribution Center with prior authorization. **NOTE:** Sukup will not be responsible for unauthorized motor replacement or repair. Labor for removal of motor not included.

WARRANTY CERTIFICATION - Warranty must be registered within one month of product shipment from Sukup facility or customer pickup from the facility to certify warranty coverage. See QR code on back page of product manual for details.

UNAPPROVED PARTS OR MODIFICATION - All obligations of Sukup under this warranty are terminated if equipment is modified or altered in any way not approved by Sukup or if parts that do not conform to specifications of original parts are used.

Safety



Read manual before installing or using product. Failure to follow instructions and safety precautions in manual can result in death or serious injury. Keep manual in a safe location for future reference.



On safety decals, this symbol and the signal words Danger, Warning, Caution and Notice draw your attention to important instructions regarding safety. They indicate potential hazards and levels of intensity.



RED - DANGER indicates an imminently hazardous situation which, if not avoided, will result in death or serious injury.



ORANGE - WARNING indicates a potentially hazardous situation which, if not avoided, could result in death or serious injury.



YELLOW - CAUTION indicates a potentially hazardous situation which, if not avoided, may result in minor or moderate injury.



BLUE - NOTICE alerts you to practices unrelated to personal injury, such as messages related to property damage.

IMPORTANT: To prevent serious injury or death to you or your family, it is essential that safety decals are clearly visible, in good condition, and applied to the appropriate equipment.

FOLLOW MANUAL & SAFETY DECAL MESSAGES

Carefully read this manual and all safety decals on your equipment.

Safety decals must be kept in good condition. Replace missing or damaged safety decals by contacting Sukup Manufacturing Co. via mail at PO Box 677, Sheffield, Iowa USA, 50475; by phone at 641-892-4222; or by e-mail at info@sukup.com.



It is the responsibility of the owner/operator to know what specific requirements, precautions, and work hazards exist. It is also the responsibility of the owner/operator to inform anyone operating or working in the area of this equipment of hazards and safety precautions that need to be taken to avoid personal injury or death. Always keep children away from bins and vehicles with flowing grain.

Make no unauthorized modifications to machine. Modifications may endanger function and/or safety of unit. Keep unit in good working condition. Keep shields in place. Replace worn or missing shields free of charge by contacting Sukup Manufacturing Co.

GRAIN BIN SAFETY

Owners/operators are responsible for developing site-specific confined space entry procedures. OSHA's confined space entry procedures (29CFR 1910.146) can be found at www.osha.gov.

If you must enter bin for repair or maintenance:

- Use a safety harness, safety line and respirator
- Station another person outside of bin
- Avoid the center of the bin
- Wear appropriate personal protective equipment
- Keep clear of all augers and moving parts



DANGER: Never enter bin unless all power is locked out and another person is present.



Unload equipment can kill or dismember!

NEVER enter bin when sweep is running!

When bin is nearly empty, sweep will travel faster. Keep away from sweep and sumps to avoid entanglement.

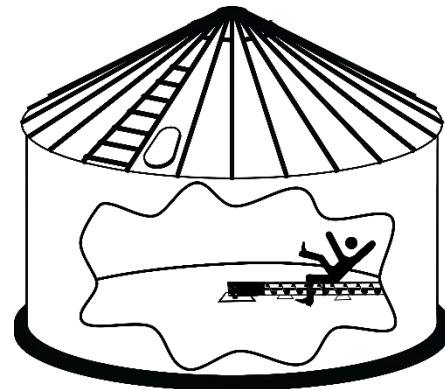

Failure to follow precautions above will result in death or serious injury.



DANGER: Flowing grain may trap and suffocate. If you enter a bin of flowing grain you can be completely submerged in grain in about 8 seconds.

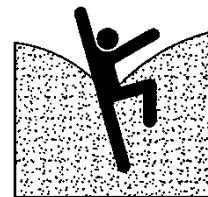

Failure to heed this warning will result in death or serious injury.

Safety

To avoid electric shock or electrocution, all equipment must be properly wired and grounded according to electrical codes. Have unit wired by qualified electrician.



Have an electrician install a main power disconnect switch capable of being locked only in OFF position. Mark disconnect clearly as to equipment it operates. Always lock out main power disconnect switch whenever equipment is not in use.

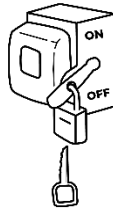

WARNING: When servicing equipment, never enter bin unless all power is locked out and another person is present. Always LOCK OUT all power and always check with voltage meter before servicing.

Failure to do so could result in death or serious injury.

Owners/operators are responsible for developing site-specific Lockout/Tagout procedures based on equipment at their work site. See OSHA's typical minimal lockout procedures (29CFR 1910.147 App A) at www.osha.gov.

WARNING: KEEP CLEAR OF ALL MOVING PARTS

Keep people (ESPECIALLY YOUTH) away from equipment, particularly during operation.

Keep away from all moving parts. Keep all shields in place. **SHUT OFF AND LOCK OUT** all power before servicing.

Failure to follow precautions above could result in death or serious injury.



WARNING: Metal is slippery when wet. To avoid falls, never carry items if climbing on bin. Maintain secure hand and foothold if climbing on bin. Failure to do so could result in death or serious injury.

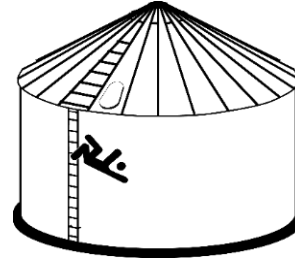

CAUTION: Metal edges are sharp. To avoid injury, wear protective clothing and handle equipment and parts with care.

Failure to do so may result in minor or moderate injury.

PERSONAL PROTECTIVE EQUIPMENT



Refer to OSHA 1910.132 (Personal Prot. Equip.)

Owners/Operators are responsible for developing site-specific personal protective equipment standards. OSHA's personal protective equipment standards (29CFR 1910.132) can be found at www.osha.gov.

EMERGENCIES – KNOW WHAT TO DO

Have emergency numbers and written directions to work site readily available in case of emergency. An area for emergency phone numbers to be recorded is provided below and at end of this manual.

Ambulance • Fire • Police: 9-1-1

Bin rescue team: _____

Emergency medical squad: _____

Address of work site: _____

Directions to work site: _____

STORED GRAIN, EQUIPMENT HAZARDS

IMPORTANT: A bin floor itself is not a hazard, but grain stored in bin and unload equipment installed in bin can create hazardous situations. Fig. 1 shows dangers of grain stored in bin, including obstructed flow, bridged grain, and collapse of bridged grain, all of which can engulf a person in bin. Obstructions or bridging should be removed by means other than entering bin.

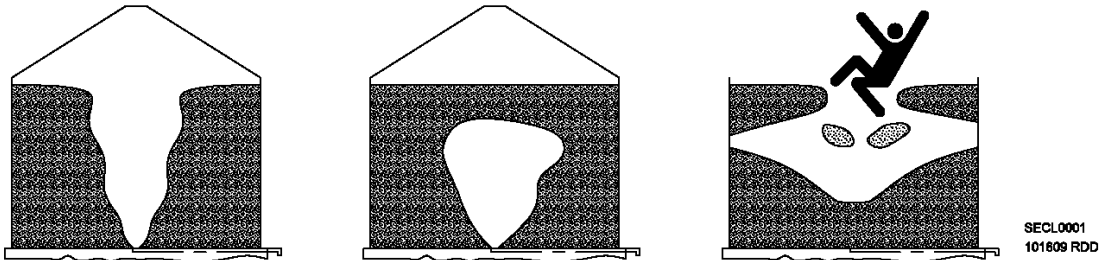

Fig. 1 – Obstructed-flow, bridged grain, collapsed bridge of grain in bin

Basic Safety Rules

1. Learn how to use controls and operate equipment.
2. Do not let anyone operate equipment without thorough training of basic operating and safety procedures. Follow a proper lockout procedure.
3. Do not modify or redesign equipment without first obtaining written approval from Sukup Manufacturing Co. Unauthorized modifications to equipment may impair function and/or safety and affect machine life.
4. Periodically check all mechanical and electrical components. Keep equipment in good working condition.
5. Handle equipment and parts with care. Wear protective clothing to avoid injury from sharp metal edges.

General safety procedures must be followed when working near or on grain bins. Engulfment and burial, falling from heights, dust and mold inhalation, pesticide exposure, electrocution, and injury from augers are hazards associated with grain bins. Refer to the Sukup Bin Operation Manual, L13920, for more specific information.

IMPORTANT: Failure to follow general safety precautions may cause serious injury or death.

SAFETY QUESTIONS OR CONCERNS

Please contact Sukup Manufacturing Co. with specific safety needs regarding this equipment or its use.

NOTICE: Do not run fans unless there is a minimum of 44" of grain over entire aeration floor. Starting fans without enough weight on floor may cause supports to be pushed out of position and cause failure of floor.

NOTICE: If bin is equipped with a sidedraw, do not use at same time sumps are being used to unload grain.



FOLLOW A PROPER LOCK-OUT PROCEDURE

This suggested procedure must be performed **EVERY TIME** your equipment is to be worked on. Following these steps will assist in preventing accidents.

- Each worker must have his/her own lock and the only key to that lock.
- Make sure equipment is not operating before turning off power.
- Notify all affected employees that equipment will be locked out for service.
- Authorized employee shall refer to the facility procedure referencing the power source for the equipment.
- Shut down equipment in a normal manner.
- All energy sources that could activate the equipment must be de-activated.
- Each person who will be working on the equipment must put a lock on any energy sources that could provide any power to the equipment.
- Confirm that power has been deactivated.
- Turn all controls for equipment back to their "off" positions.
- **NO ONE** is to return power to equipment until all work on it has been completed and all locks have been removed.

Facility management needs to proactively train employees to ensure use of proper lockout procedures before working on the equipment. Management also needs to inspect equipment for any covers or guards not in their proper place. It is everyone's responsibility to report any missing grates, guards, equipment failures or failures to lock out. Make certain that no cover is removed unless power is locked out.

NOTE: Refer to OSHA document 1910.147 App A for a typical minimal lockout procedure.



DANGER: Never enter bin unless all power is locked out and another person is present. Entanglement in rotating auger will cause death or serious injury.

SAFETY DECAL PLACEMENT

Two "**DANGER DO NOT ENTER this bin!**" decals, L0258A, are supplied with Sukup bin equipment. Both decals should be placed where people entering bin or storage building will see them.

Install one "**DANGER**" decal L0258A on bin sheet next to door, opposite of hinge side.

Install other "**DANGER**" decal L0258A next to ladder leading to roof.

One "**WARNING**" decal L0281 is also supplied. It should be placed next to "**DANGER**" decal on bin sheet next to door.

If suggested locations are not in full view, place safety decals in a more suitable location. Be certain not to cover any safety decals that are already there.

It is essential that these safety decals be mounted on bin to warn and remind of potential hazards. Decals may need to be replaced if damaged or worn. Order replacement safety decals or shields free of charge by contacting Sukup Manufacturing Co. by mail at PO Box 677, Sheffield, Iowa, USA, 50475; by phone at 641-892-4222; or by e-mail at info@sukup.com. Please specify computer number. Use decal placement drawing to determine location of decals.

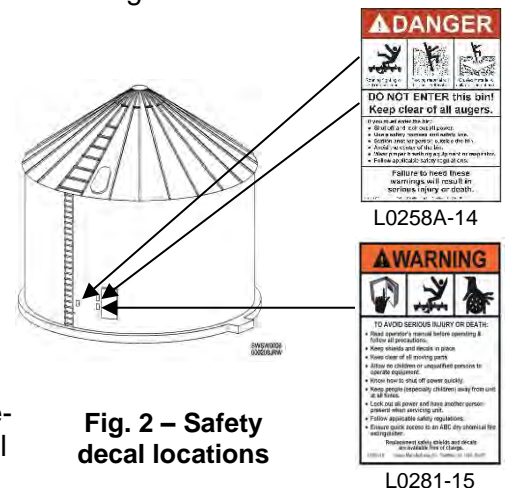

SUPERWAVE SUPPORTS INSTALLATION

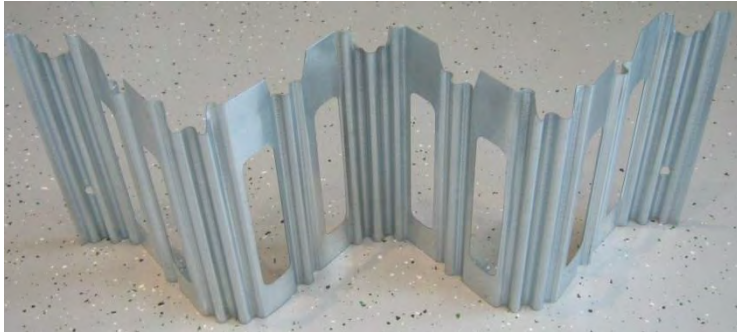

Image 1 – Full SuperWave Support



Image 2 – Half SuperWave Support

NOTE: Start floor installation on opposite side of bin from where unload auger or conveyor exits bin.

1. Find exact center of bin and mark it.
2. Determine where unload auger or conveyor will be located. Mark a line through center of bin along path where unload will be installed. Extend line to far end of bin and upward to top of sidewall sheet.
3. Mark lines on floor parallel to centerline at 1/2 of support spacing given for SuperWave Supports. See applicable table on following pages.
4. Draw parallel lines at suggested spacing, continuing across floor to bin walls.
5. Start at far side of bin and place SuperWave Supports on three or four lines marked on floor on each side of centerline. See Image 3. Middle two supports should be positioned up against bin wall or as close to it as possible to allow for perpendicular installation of flooring.



Image 3 – Positioning SuperWave Supports



Image 4 – Marking bin wall, installing first plank

6. Mark center of shortest floor plank. Position plank as shown in Image 4 so middle of plank lines up with mark on bin wall.
7. Tilting plank upward, place channel of plank into cutout of SuperWave Support. Ensure channel is between first and second tabs of all SuperWave Supports, then lower plank into place until seated firmly.
8. Shorter planks used at start and finish usually require an extra support, as do split planks. Maximum unsupported overhang is 7". Use Half SuperWaves to eliminate plank overhangs over 7".
9. Place next plank in bin, adjusting supports as necessary to ensure plank channels fit into cutouts in supports. Tamp plank into place. Ensure plank is centered in bin and there is an equal distance from end of each plank to bin wall. Make sure supports are on lines marked on floor.
10. Install planks until first set of supports is almost covered. Place next SuperWave Support.
11. After installing first few rows of flooring and supports, install a few pieces of flashing to hold floor in place. See Page 32 for flashing installation.



Fig. 3 – Maximum end-to-end gap is 4-11/16" for Hawk Cut flooring

12. Continue adding SuperWave Supports as installation of flooring moves toward center of bin. **NOTICE:** Ensure that supports stay centered on floor lines. **For Hawk Cut flooring there can be 4-11/16" end-to-end gaps between SuperWave supports as shown in Fig. 3. Both ribs of floor plank must be supported.** If installing long planks – 30 feet or longer – have three people putting each plank into place, one near each end and one in middle. If planks are 40 feet long, a fourth crew member will be helpful.

NOTE: Use Double Super Supports instead of SuperWave Supports directly in front of aeration fan inlet to allow better airflow. See Page 28.

13. Install sump(s) as directed in appropriate unload manual. Position Double Super Supports (as opposed to SuperWave Supports) along sides of sump(s) to support ends of floor planks. Use bridge over sump gate if required. See Pages 17-26. Use SuperWave Supports for rest of floor away from sump(s) and unload system.

14. Continue installing remainder of flooring and supports.

15. Install remainder of flashing.

16. Mount "Never Enter Bin" decal and "Safe Operation" decal near bin openings as described in safety packet, A3399 (bundled with floor).

IMPORTANT: Ensure supports do not block sump gate(s) from opening.

SUPPORTING PLANKS AT SIDEWALL

Maximum unsupported overhang of Hawk Cut floor plank at sidewall is 7". Use Half SuperWaves to eliminate plank overhangs along sidewall. See Fig. 4, which shows typical SuperWave spacing in 36' diameter bin.

If either floor plank at splice extends more than 7" from SuperWave Support, additional supports will be needed. See Page 29.

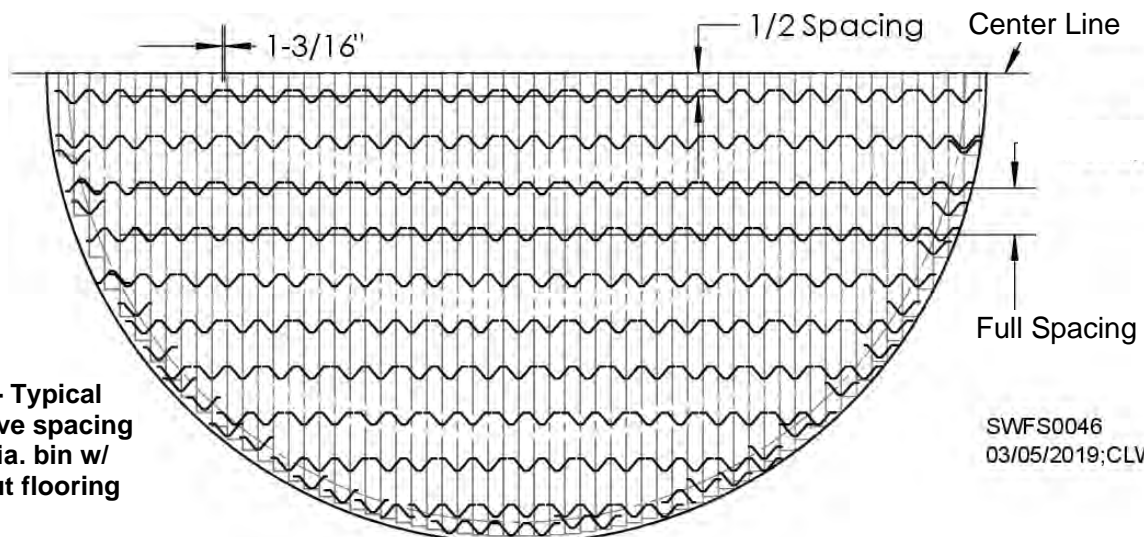

Fig. 4 – Typical SuperWave spacing in 36' dia. bin w/ Hawk Cut flooring

SWFS0046
03/05/2019;CLW

SuperWave Supports Spacing

SUPERWAVE™ SUPPORT REQUIREMENTS FOR HAWK CUT FLOORS

BIN DIA.	# OF RINGS - SUKUP BINS (44" RING HEIGHT)																										
	3 & 4	5	6	7	8	9	10	11	12	13	14	15	16														
12"	17	19	20	22	23	26	30	20	28	22	31	33	34	37	38	41	42	44	45	48	49	52	53	56	57	59	
15"	33	19	31	19	30	20	30	20	28	22	25	26	26	24	20	28	20	20	19	28	19	28	19	30	17	30	17
16" (5M)	32	28	30	30	27	30	20	30	27	30	26	32	25	38	20	40	30	30	19	40	19	40	18	44	17	44	17
18"	32	30	29	32	27	32	20	30	27	36	25	32	26	38	20	46	30	30	19	46	18	46	18	51	17	51	17
18" 7"	31	40	29	42	27	42	20	30	26	42	25	54	25	44	20	57	30	30	19	63	18	63	18	65	17	65	17
19"	31	48	28	48	27	48	20	30	26	48	26	50	25	50	20	65	30	30	19	69	18	69	18	71	17	71	17
19" 8" (6M)	31	48	28	48	27	48	20	30	26	48	26	50	25	50	20	65	30	30	19	69	18	69	18	71	17	71	17
21"	31	54	28	54	26	54	20	30	24	56	24	56	24	56	20	69	30	30	19	73	18	73	18	79	17	79	17
21" 8"	31	62	28	62	25	62	24	30	24	62	24	62	24	62	20	81	30	30	18	83	18	83	18	85	17	85	17
22" 11" (7M)	30	64	27	70	25	75	24	30	23	79	22	79	22	79	20	85	30	30	18	85	18	85	18	91	17	91	17
24"	30	72	27	83	23	83	23	30	23	89	22	89	22	89	20	91	30	30	17	99	17	99	17	106	16	106	16
24" 9"	30	77	27	85	23	87	23	30	23	91	22	91	22	91	20	98	30	30	17	105	17	105	17	111	16	111	16
26" 3" (8M)	29	85	27	91	23	99	22	105	21	105	21	105	21	105	20	113	30	30	17	120	17	120	17	128	16	128	16
27"	29	83	27	85	25	107	23	111	22	113	21	113	21	113	20	125	30	30	17	138	17	138	17	152	16	152	16
27" 10"	29	85	27	105	23	117	22	123	21	129	20	138	20	148	20	154	30	30	17	152	17	152	17	168	16	168	16
28" 6" (9M)	28	115	26	125	23	136	22	148	20	148	20	148	20	148	20	164	30	30	17	172	17	172	17	182	16	182	16
30"	28	123	26	131	23	150	21	156	20	162	19	176	18	182	17	192	30	30	16	182	17	182	17	202	15	202	15
31"	28	137	26	147	24	160	22	168	20	176	19	188	18	198	18	220	30	30	16	220	18	220	18	231	15	231	15
33"	28	149	26	155	24	172	22	180	20	188	19	208	18	208	18	231	30	30	16	231	18	231	18	249	15	249	15
34"	28	172	25	176	24	184	22	194	20	202	19	234	18	234	18	259	30	30	16	259	18	259	18	281	15	281	15
36" 1" (11M)	28	172	25	176	24	184	22	194	20	202	19	234	18	234	18	259	30	30	16	259	18	259	18	281	15	281	15
37" 1"	27	178	25	182	23	202	22	210	20	222	19	254	18	254	18	281	30	30	16	281	18	281	18	301	15	301	15
42" Split	26	271	24	281	23	301	21	310	20	330	19	330	19	330	19	346	30	30	17	385	16	407	15	407	15	435	14
42" 8" (13M) Split	26	276	24	290	23	314	21	329	20	339	19	339	19	339	19	361	30	30	17	402	16	422	15	422	15	452	14
43" 3" Split	26	277	24	291	23	315	21	330	20	340	19	362	18	362	18	380	30	30	17	403	16	423	15	423	15	453	14
48" Split	26	354	24	381	22	396	21	416	20	435	19	458	18	458	18	483	30	30	17	541	15	541	15	577	14	577	14
49" 3" (15M) Split	26	370	24	383	22	416	21	433	20	453	19	472	18	472	18	501	30	30	17	559	15	559	15	600	14	600	14
54" Split	24	476	22	486	21	521	20	546	19	573	18	606	17	636	16	636	16	673	15	673	15	721	14	721	14	721	14
55" 8" Split	24	506	22	533	21	554	20	583	19	616	18	644	17	681	16	722	15	722	15	776	14	776	14	800	14	800	14
59" 1" (18M) Split	23	566	22	620	20	639	19	679	18	714	17	757	16	757	16	802	15	802	15	858	14	858	14	882	14	882	14
60" Split	23	579	22	635	20	662	19	702	18	702	18	776	17	776	17	826	15	826	15	882	14	882	14	910	14	910	14
61" 10" Split	23	623	22	670	20	707	19	744	18	785	17	828	16	828	16	884	15	884	15	941	14	941	14	941	14	941	14
72" Split	22	895	20	935	19	990	18	1041	17	1041	17	1059	16	1176	15	1176	15	1250	14	1250	14	1344	13	1344	13	1344	13
75" Split	21	969	20	1015	19	1070	18	1129	17	1183	16	1268	15	1268	15	1356	14	1356	14	1454	14	1454	14	1454	14	1454	14
78" Double Split	21	1043	20	1098	19	1158	18	1217	17	1284	16	1378	15	1378	15	1472	14	1472	14	1579	14	1579	14	1579	14	1579	14

Key: 1 2 3

1 = Number of SuperWave Supports
2 = SuperWave Support Spacing in inches
3 = Number of Half SuperWave Supports (h)

© 11/8/2022

Z-POST SUPPORTS INSTALLATION INSTRUCTIONS

NOTE: Z-Post supports can be used in bins up to 16 rings tall.

Placement with one fan

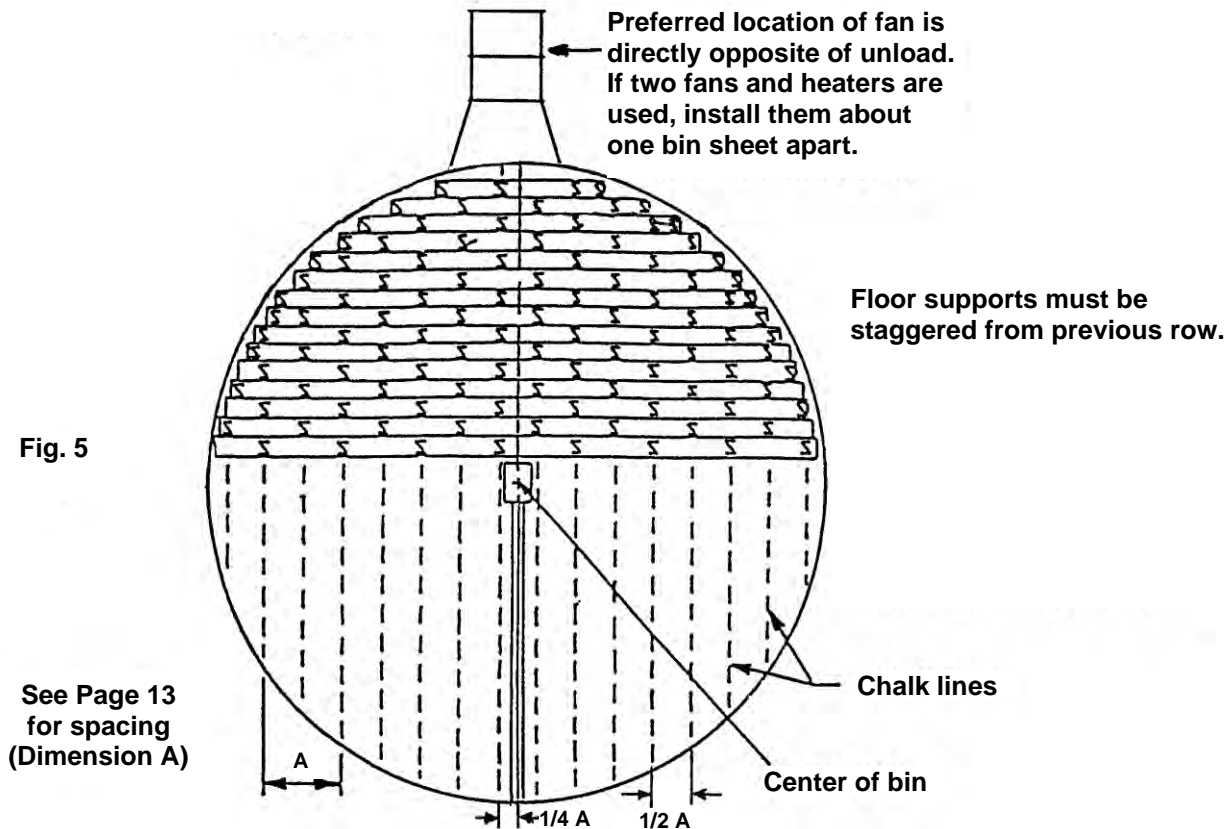

NOTICE: Failure to carefully follow installation instructions will void warranty and may cause floor failure.

1. Determine exact bin diameter and eave height. See table on Page 13 to determine quantity of floor supports and spacing (Dimension A in Fig. 5) required for each plank.
2. Determine exact center of bin. Mark chalk lines at $\frac{1}{4}$ of support spacing (Dim. A) to left and right of centerline. Continue marking parallel lines toward bin walls at $\frac{1}{2}$ of support spacing. See Fig. 5.

NOTICE: It is essential to mark chalk lines on floor to ensure correct support spacing throughout bin. Even a few incorrectly-spaced supports may cause floor failure.

3. Take first plank (shortest) and turn upside down. Place Z-Post floor support into plank. Make sure all upper tabs of support are between channels of floor plank. Insert additional Z-Post supports as needed at required spacing.
4. Place first plank (with supports installed) against bin wall with open channel toward center of bin, ready to receive next plank.

IMPORTANT: Corners of first plank must touch bin wall so flashing will cover gap properly.

5. Position next row of supports at required spacing. Slide each support against open channel of previously installed plank as shown in Fig. 7 so that both notched "T" tabs fit over open channel. See Fig. 8.

NOTE: Do **NOT** hook tab of support under tail of floor plank.

Z SUPPORTS INSTALLATION

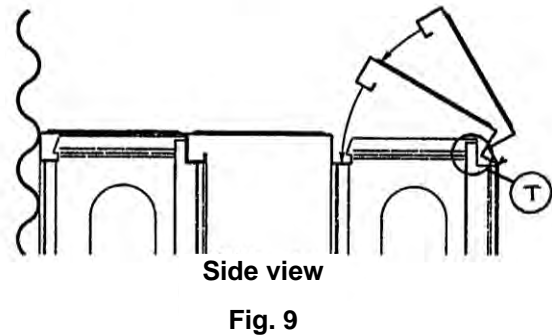
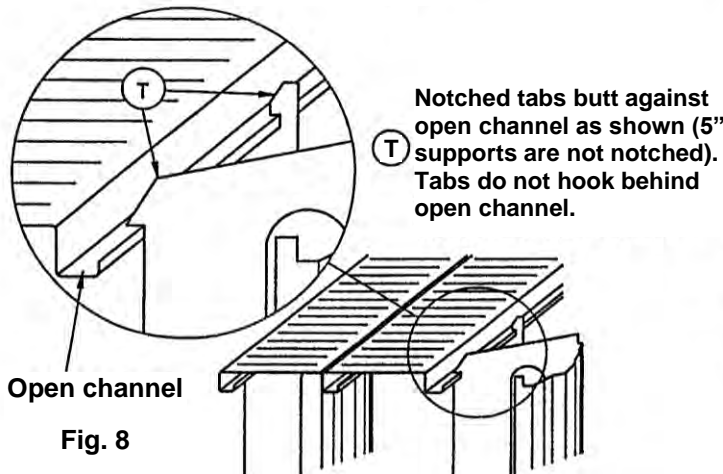
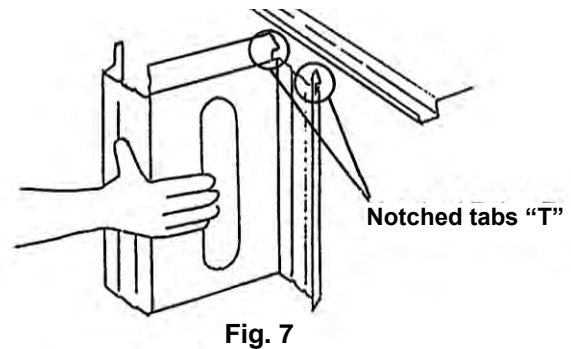
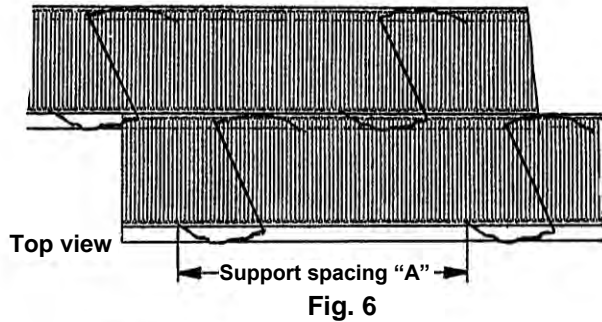

6. Place an extra support at end of floor plank if there is more than 7" of overhang. Shorter planks used at start and finish usually require an extra support. Each side of support (if possible) should support two floor planks.
 7. Lay open channel of next floor plank on top of row of supports as shown in Fig. 9. Ensure there is an equal distance from each end of plank to bin wall. Snap plank down into place. Check that all upper tabs of support are between channels of floor plank and are not exposed.
 8. Place next row of supports at designated support spacing so they are offset from previous row by one-half the spacing distance. See Fig. 5. Use chalk lines to ensure correct spacing.
 9. Repeat Steps 5-8.
 10. After installing first few rows of flooring and supports, install a few pieces of flashing to hold floor in place. See Page 32 for flashing installation.
- NOTE:** On smaller bins, flashing may need to be cut across center of perforated section for better fit.
11. Continue floor installation until all supports and planks are installed.
 12. Install remainder of flashing. See Page 32.
 13. Mount "Never Enter Bin" decal and "Safe Operation" decal near bin openings as described in safety packet A3399 (bundled with floor).

IMPORTANT: Make sure concrete is level and floor supports are placed under each floor plank. Stagger supports as shown in Fig. 5.

Z-Post Supports Spacing

Z-POST SUPPORT & SPACING FOR HAWK CUT FLOORS

TOTAL NUMBER OF Z-POST SUPPORTS/SPACING*

BIN DIAMETER	20 GA. Z-POST REQUIREMENTS									18 GA. Z-POST REQUIREMENTS							Cont. Flow Bottom Unload **	Recirc- ulator ***
	#OF RINGS - SUKUP BINS (44" RING HEIGHT)									#OF RINGS - SUKUP BINS (44" RING HEIGHT)								
	3 & 4	5	6	7	8	9	10	11	12	13	14	15	16					
	EAVE HEIGHT (FEET)									EAVE HEIGHT (FEET)								
16'	17' - 19'	20' - 22'	23' - 26'	27' - 30'	31' - 33'	34' - 37'	38' - 41'	42' - 44'	45' - 48'	49' - 52'	53' - 56'	57' - 59'						
12'	59 54"	59 54"	63 50"	69 46"	75 41"	80 37"	78 38"	84 35"	86 32"	90 30"	94 28"	98 26"	104 25"	86 32"	112 24"			
15'	85 54"	85 54"	88 50"	94 46"	100 41"	110 37"	108 38"	116 35"	120 32"	130 30"	134 28"	143 26"	149 25"	126 32"	159 24"			
16' 5" (5M)	96 54"	96 54"	106 50"	110 46"	117 41"	125 37"	123 38"	133 35"	142 32"	148 30"	156 28"	164 26"	172 25"	153 32"	195 24"			
18'	120 54"	120 54"	126 49"	133 45"	145 40"	156 36"	154 37"	164 34"	174 32"	188 29"	196 27"	206 26"	223 24"	184 32"	230 24"			
18' 7"	136 54"	136 54"	146 49"	156 45"	168 40"	182 36"	178 37"	189 34"	203 32"	216 29"	228 27"	234 26"	248 24"	193 32"	245 24"			
19'	136 54"	136 54"	146 49"	156 45"	168 40"	182 36"	178 37"	189 34"	203 32"	216 29"	228 27"	234 26"	248 24"	198 32"	258 24"			
19' 8" (6M)	142 54"	146 53"	158 49"	168 44"	184 40"	195 36"	192 37"	205 34"	222 31"	234 29"	248 27"	254 26"	274 24"	215 32"	276 24"			
21'	158 54"	160 53"	170 49"	186 44"	198 40"	215 36"	211 37"	223 34"	242 31"	254 29"	272 27"	280 26"	300 24"	238 32"	305 24"			
21' 8"	175 54"	179 53"	187 49"	206 44"	218 40"	238 36"	234 37"	250 34"	266 31"	283 29"	298 27"	310 26"	336 24"	252 32"	328 24"			
22' 11" (7M)	187 54"	191 53"	200 49"	218 44"	238 40"	258 36"	252 37"	272 34"	291 31"	305 29"	324 27"	332 26"	360 24"	290 32"	368 24"			
24'	199 54"	214 50"	220 48"	230 44"	258 39"	288 35"	278 36"	290 34"	311 31"	334 29"	352 27"	374 25"	392 24"	308 32"	394 24"			
24' 9"	216 54"	236 50"	240 48"	257 44"	282 39"	306 35"	300 36"	318 34"	338 31"	362 29"	387 27"	408 25"	424 24"	326 32"	422 24"			
26' 3" (8M)	252 50"	252 50"	254 48"	281 43"	310 38"	334 35"	322 36"	346 33"	366 31"	387 29"	411 27"	440 25"	454 24"	370 32"	482 24"			
27'	262 50"	262 50"	273 48"	295 43"	324 38"	356 35"	346 36"	374 33"	390 31"	411 29"	440 27"	474 25"	490 24"	383 32"	497 24"			
27' 10"	288 50"	288 50"	298 48"	322 43"	355 38"	376 35"	371 36"	402 33"	426 31"	446 29"	478 27"	509 25"	532 24"	417 32"	532 24"			
29' 6" (9M)	320 50"	320 50"	360 44"	367 42"	401 38"	438 34"	424 36"	458 33"	496 30"	531 28"	564 26"	584 25"	604 24"	466 32"	602 24"			
30'	320 50"	320 50"	360 44"	367 42"	401 38"	438 34"	424 36"	458 33"	496 30"	531 28"	564 26"	584 25"	604 24"	468 32"	612 24"			
31'	341 50"	341 50"	378 44"	398 42"	434 38"	477 34"	452 36"	491 33"	530 30"	562 28"	604 26"	625 25"	647 24"	506 32"	662 24"			
33'	378 50"	378 50"	424 44"	466 40"	506 37"	546 34"	530 35"	582 32"	612 30"	652 28"	708 26"	734 25"	798 23"	559 32"	733 24"			
34'	416 50"	416 50"	459 44"	498 40"	536 37"	574 34"	558 35"	607 32"	637 30"	674 28"	726 26"	752 25"	810 23"	612 32"	798 24"			
36'	455 50"	455 50"	508 44"	552 40"	588 37"	657 33"	620 35"	669 32"	712 30"	756 28"	806 26"	870 24"	910 23"	662 32"	878 24"			
36' 1" (11M)	455 50"	455 50"	508 44"	552 40"	588 37"	657 33"	620 35"	669 32"	712 30"	756 28"	806 26"	870 24"	910 23"	676 32"	893 24"			
37' 1"	493 50"	493 50"	544 44"	592 40"	634 37"	697 33"	661 35"	716 32"	764 30"	812 28"	869 26"	924 24"	964 23"	722 32"	938 24"			
42' Split	670 50"	738 44"	738 44"	801 40"	878 36"	968 32"	968 32"	992 31"	1051 29"	1118 27"	1156 26"	1237 24"	1290 23"					
42'8"(13M) Split	712 50"	790 44"	790 44"	855 40"	930 36"	1030 32"	1030 32"	1051 31"	1114 29"	1190 27"	1226 26"	1311 24"	1364 23"					
43' 3" Split	712 50"	790 44"	790 44"	855 40"	930 36"	1030 32"	1030 32"	1051 31"	1114 29"	1190 27"	1226 26"	1311 24"	1364 23"					
48' Split	848 50"	955 44"	967 43"	1128 36"	1152 35"	1248 32"	1248 32"	1278 31"	1358 29"	1443 27"								
49'3"(15M) Split	904 50"	1003 44"	1020 43"	1186 36"	1217 35"	1310 32"	1310 32"	1352 31"	1426 29"	1522 27"								
54' Split	1184 44"	1184 44"	1288 40"	1406 36"	1564 32"	1649 30"	1564 32"	1649 30"										
55' 8" Split	1291 44"	1291 44"	1398 40"	1523 36"	1692 32"	1792 30"	1692 32"	1792 30"										
59'1"(18M) Split	1412 44"	1412 44"	1528 40"	1674 36"	1866 32"	1965 30"	1866 32"	2030 29"										
60' Split	1450 44"	1450 44"	1578 40"	1728 36"	1914 32"	2032 30"	1914 32"	2094 29"										
61' 10" Split	1574 44"	1574 44"	1700 40"	1864 36"	2075 32"	2194 30"	2075 32"	2258 29"										
72' Split	2226 40"	2456 36"	2735 32"	3083 28"	3083 28"	3083 28"	3083 28"	3194 27"										
75' Split	2412 40"	2657 36"	2960 32"	3340 28"	3340 28"	3340 28"	3340 28"	3457 27"										
78' Double Split	2936 36"	2936 36"	3264 32"	3680 28"	3680 28"	3680 28"	3680 28"	3802 27"										

*Example: 59 54" indicates a total of 59 supports at 54" spacing on each plank.

**Continuous-flow Bottom Unload: Use 20 ga. supports. Additional supports are required around center sump. Maximum grain depth is 20'.

***For Recirculation devices: Use 20 ga. supports with Hawk Cut flooring. Additional supports are placed around center sump. Maximum grain depth is 20'. Stirring machines are not recirculators. Therefore, support spacing is based on eave height.

©3/12/19

SUPER SUPPORTS INSTALLATION

Includes Standard Super Supports and Flat Top Super Supports

Fig. 10 shows a Full Super Support, which is also available with a flat top. Fig. 11 shows a Double Super Support, which can be used with either standard or flat top Super Support. **NOTE:** Double Super Supports can be cut in half to use as singles.

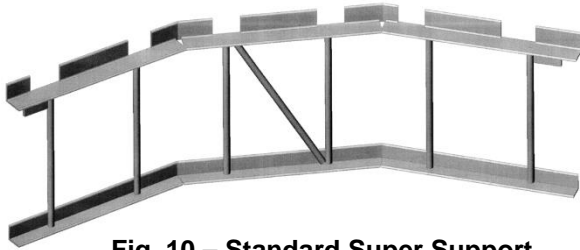

Fig. 10 – Standard Super Support

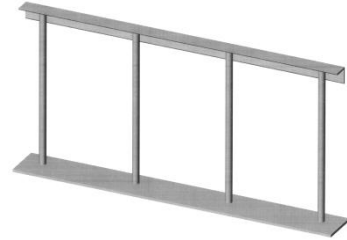

Fig. 11 – Double Super Support

See Super Supports requirements on Page 16:

With recirculation devices, center half of bin is on 11" spacing; outside half is at 22". Use 20ga Hawk Cut flooring.

NOTE: With Continuous Flow Bottom Unload and Recirculation devices, maximum grain depth is 20'. These specifications are for Hawk Cut floors. Place additional supports around center sump. Stirring machines are not recirculators; therefore, support spacing is based on eave height.

Key:

1	2
3	4

1 = Number of Full Super Supports 2 = Super Support Spacing in inches
3 = Number of Z Supports (z)* 4 = Number of Double Super Supports (d)

*Bins 10 rings and taller require 18ga supports

NOTE: Super Supports 17" tall used only in bins 6 rings tall or shorter. Use 13-1/4" in all others.

Installation Steps for Standard Super Supports

1. Find exact center of bin and mark it.
2. Determine where unload auger or conveyor will be located. Mark a line through center of bin along path where unload will be installed.
3. Mark lines parallel to centerline at 1/2 of spacing given for Super Support. See table on Page 16. Mark on both sides of centerline.
4. Mark lines parallel to lines at required spacing, continuing across floor to bin wall.
5. Start at far side of bin and place Super Supports on three or four lines marked on floor on each side of centerline as shown in Fig. 12. Add Double Super Supports to Super Supports closest to center of bin as shown in Fig. 12 if needed to comply with spacing requirement in applicable table. Run a self-drilling screw through floor plank into Double Super Support to hold support in place.
6. Place first plank in bin. Position supports so plank channel runs through cutouts in supports.
7. Place a Z-Post support at end of plank (at wall or at plank splice) if there is more than 7" of overhang in bin up to 16 rings tall, if there is more than 4" of overhang in bin 17-20 rings tall, or more than 2-1/2" in bin 21 or more rings tall. Shorter planks used at start and finish usually require an extra support.

Super Supports Installation

8. Place next plank in bin, adjusting supports as needed to ensure plank channels fit into cutouts in supports. Add extra supports on ends if necessary. Ensure plank is centered in bin and there is an equal distance from each end of plank to bin wall. Make sure supports are spaced correctly and lie on lines marked on floor.
9. Install planks until first set of supports is almost covered. Place next support for that spacing so floor plank will rest on ends of each support without supports overlapping.
10. Repeat Steps 7-9.
11. After installing first few rows of flooring and supports, install a few pieces of flashing to hold floor in place. See Page 32 for flashing installation.
12. Continue installing remainder of flooring and supports.
13. Install remainder of flashing.
14. Mount "Never Enter Bin" decal and "Safe Operation" decal near bin openings as described in safety packet, A3399 (bundled with floor).

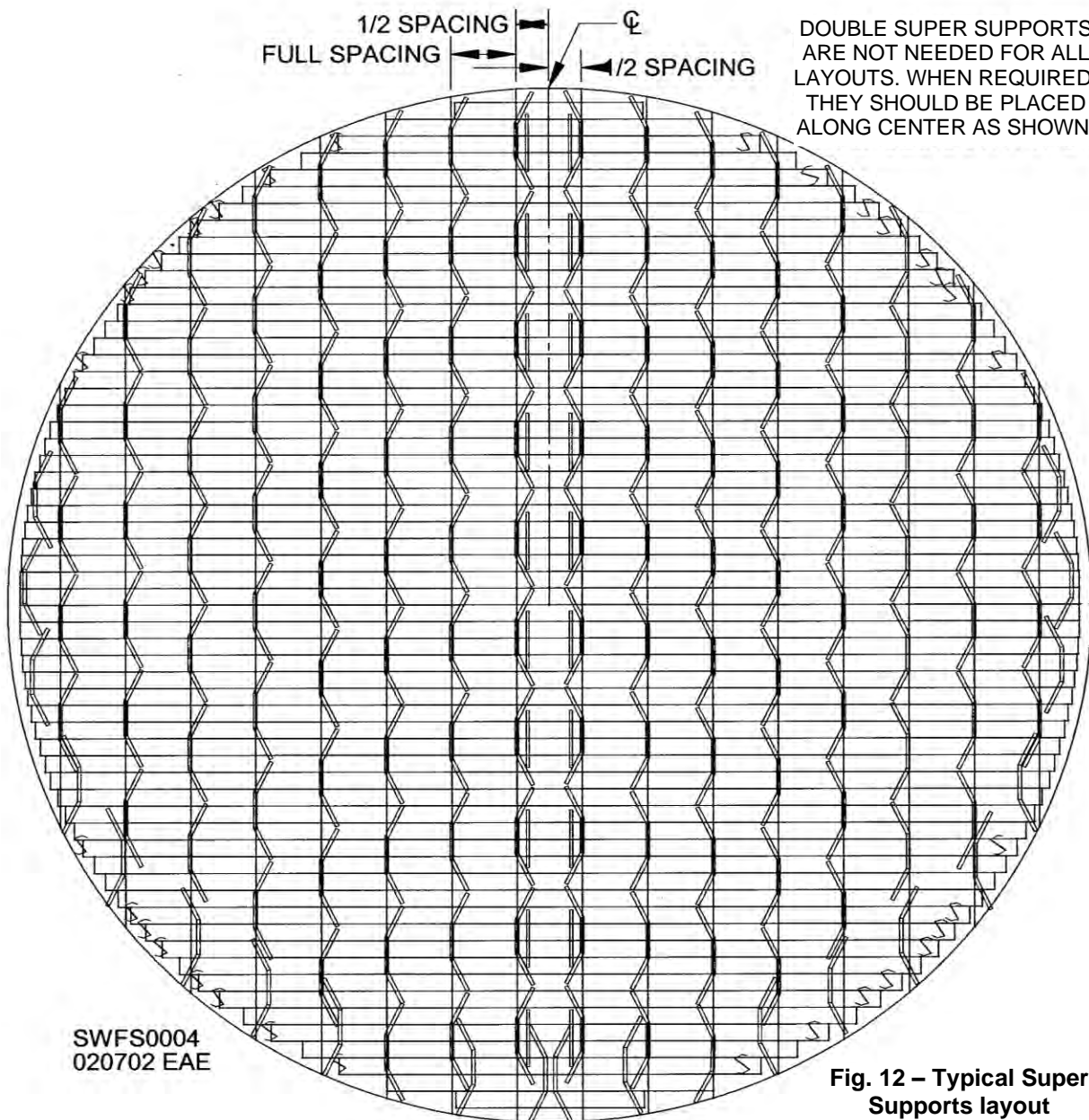

SUPER SUPPORT REQUIREMENTS FOR HAWK CUT FLOOR

BIN DIAMETER	# OF RINGS - SUKUP BINS (44" RING HEIGHT)																CONTINUOUS FLOW BOTTOM UNLOAD	RECYCLATOR
	3 & 4	5	6	7	8	9	10	11	12	13	14	15	16					
12'	16'	30'	16'	17' - 19'	20' - 22'	23' - 26'	27' - 30'	31' - 33'	34' - 37'	38' - 41'	42' - 44'	45' - 48'	49' - 52'	53' - 56'	57' - 59'	18	26' 24	11/22'
15'	30'	26'	30'	26'	34'	34'	34'	34'	34'	34'	34'	34'	34'	34'	34'	14	26	11/22'
16' 5" (5M)	30'	26'	30'	26'	34'	34'	34'	34'	34'	34'	34'	34'	34'	34'	34'	14	26	11/22'
18'	30'	34'	30'	34'	30'	36'	36'	36'	36'	36'	36'	36'	36'	36'	36'	14	26	11/22'
18' 7"	30'	34'	30'	34'	30'	36'	36'	36'	36'	36'	36'	36'	36'	36'	36'	14	26	11/22'
19'	30'	34'	30'	34'	30'	36'	36'	36'	36'	36'	36'	36'	36'	36'	36'	14	26	11/22'
19' 8" (6M)	30'	34'	30'	34'	30'	36'	36'	36'	36'	36'	36'	36'	36'	36'	36'	14	26	11/22'
21'	30'	34'	30'	34'	30'	36'	36'	36'	36'	36'	36'	36'	36'	36'	36'	14	26	11/22'
21' 8"	30'	34'	30'	34'	30'	36'	36'	36'	36'	36'	36'	36'	36'	36'	36'	14	26	11/22'
22' 11" (7M)	30'	34'	30'	34'	30'	36'	36'	36'	36'	36'	36'	36'	36'	36'	36'	14	26	11/22'
24'	30'	34'	30'	34'	30'	36'	36'	36'	36'	36'	36'	36'	36'	36'	36'	14	26	11/22'
24' 9"	30'	34'	30'	34'	30'	36'	36'	36'	36'	36'	36'	36'	36'	36'	36'	14	26	11/22'
26' 3" (8M)	30'	34'	30'	34'	30'	36'	36'	36'	36'	36'	36'	36'	36'	36'	36'	14	26	11/22'
27'	30'	34'	30'	34'	30'	36'	36'	36'	36'	36'	36'	36'	36'	36'	36'	14	26	11/22'
27' 10"	30'	34'	30'	34'	30'	36'	36'	36'	36'	36'	36'	36'	36'	36'	36'	14	26	11/22'
29' 6" (9M)	30'	34'	30'	34'	30'	36'	36'	36'	36'	36'	36'	36'	36'	36'	36'	14	26	11/22'
30'	30'	34'	30'	34'	30'	36'	36'	36'	36'	36'	36'	36'	36'	36'	36'	14	26	11/22'
31'	30'	34'	30'	34'	30'	36'	36'	36'	36'	36'	36'	36'	36'	36'	36'	14	26	11/22'
33'	30'	34'	30'	34'	30'	36'	36'	36'	36'	36'	36'	36'	36'	36'	36'	14	26	11/22'
34'	30'	34'	30'	34'	30'	36'	36'	36'	36'	36'	36'	36'	36'	36'	36'	14	26	11/22'
36'	30'	34'	30'	34'	30'	36'	36'	36'	36'	36'	36'	36'	36'	36'	36'	14	26	11/22'
36' 1" (11M)	30'	34'	30'	34'	30'	36'	36'	36'	36'	36'	36'	36'	36'	36'	36'	14	26	11/22'
37' 1"	30'	34'	30'	34'	30'	36'	36'	36'	36'	36'	36'	36'	36'	36'	36'	14	26	11/22'
42' Split	30'	34'	30'	34'	30'	36'	36'	36'	36'	36'	36'	36'	36'	36'	36'	14	26	11/22'
42' 8" (13M) Split	30'	34'	30'	34'	30'	36'	36'	36'	36'	36'	36'	36'	36'	36'	36'	14	26	11/22'
43' 3" Split	30'	34'	30'	34'	30'	36'	36'	36'	36'	36'	36'	36'	36'	36'	36'	14	26	11/22'
48' Split	30'	34'	30'	34'	30'	36'	36'	36'	36'	36'	36'	36'	36'	36'	36'	14	26	11/22'
49' 3" (15M) Split	30'	34'	30'	34'	30'	36'	36'	36'	36'	36'	36'	36'	36'	36'	36'	14	26	11/22'
54' Split	30'	34'	30'	34'	30'	36'	36'	36'	36'	36'	36'	36'	36'	36'	36'	14	26	11/22'
55' 8" Split	30'	34'	30'	34'	30'	36'	36'	36'	36'	36'	36'	36'	36'	36'	36'	14	26	11/22'
59' 1" (18M) Split	30'	34'	30'	34'	30'	36'	36'	36'	36'	36'	36'	36'	36'	36'	36'	14	26	11/22'
60' Split	30'	34'	30'	34'	30'	36'	36'	36'	36'	36'	36'	36'	36'	36'	36'	14	26	11/22'
61' 10" Split	30'	34'	30'	34'	30'	36'	36'	36'	36'	36'	36'	36'	36'	36'	36'	14	26	11/22'
72' Split	30'	34'	30'	34'	30'	36'	36'	36'	36'	36'	36'	36'	36'	36'	36'	14	26	11/22'
75' Split	30'	34'	30'	34'	30'	36'	36'	36'	36'	36'	36'	36'	36'	36'	36'	14	26	11/22'
78' Double Split	30'	34'	30'	34'	30'	36'	36'	36'	36'	36'	36'	36'	36'	36'	36'	14	26	11/22'

SUPPORTING FLOOR OVER UNLOAD SYSTEM

Bridging kits are available from Sukup Manufacturing Co. to simplify installation of flooring over unload auger or conveyor and to improve strength and stability of flooring over unload system. Bridging is used with Standard or Heavy Duty Double Super Supports.

Start by examining table below. It identifies locations where floor bridging is needed in Sukup bins depending on unload system and width of center sump gate and intermediate sumps. Kit P5110 consists of one P5115 angle. Kit P5111 consists of one P5113 angle. Table also identifies kit needed (P5110 or P5111) if bridging is needed.

UNLOAD SYSTEM	CENTER SUMP GATE WIDTH	INTERMEDIATE SUMP WIDTH	UNLOAD WIDTH
6" Sweepway	16" (P5110)		6" (P5110)
8" Sweepway	23-1/2" (P5111)	NA	8" (P5110)
10" Sweepway	23-1/2" (P5111)		10" (P5110)
10" U-Trough	NA	NA	10-1/2"* (P5110)
8" Loop w/ Power Sweep	16" (P5110)	14" (P5110)	8" (P5110)
10" Loop w/ Power Sweep	16" (P5110)	14" (P5110)	10" (P5110)
12" Loop w/ Power Sweep	20" (P5111)	20" (P5111)	12" (P5110)
12" wide Conveyor w/ Power Sweep			16-1/2" (P5111)
16" wide Conveyor w/ Power Sweep	NA	NA	20-1/2" (P5111)
21" wide Conveyor w/ Power Sweep			25" (P5111)

*U-Trough unload width is 14" at splices

Bridging locations & Kit # (P5110 or P5111)

Fig. 13 and table below show dimensions of bridges. Dims. A & B depend on height of Double Super Support (Standard & HD). Dimension A is from bin pad to notched portion of bridge. Dimension B is from bin pad to bottom of bridge.

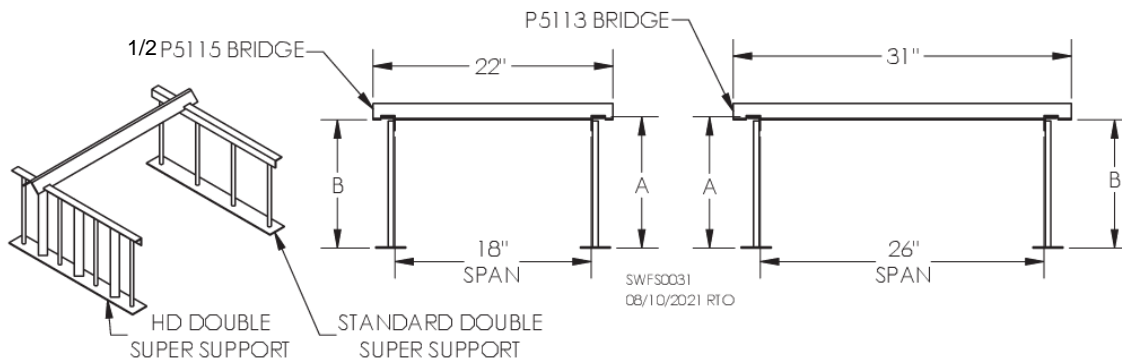

Fig. 13 – Bridge dimensions per Double Super Support height

DBL. SUPER SUPPORT HGT.	13-1/4"	17"
DIM. A	12"	17-1/8"
DIM. B	11-3/4"	16-7/8"

IMPORTANT: Some bin sweeps (including, but not limited to, 5,000 BPH Paddle Sweep and Paddle Sweepway) require additional floor support where sweep will be parked. See Page 27 and bin sweep installation manual for details.

Supporting Floor over Unload System

To install Sukup bridging, place Double Super Supports (Standard or Heavy-Duty) on each side of unload (Unload not shown for clarity). Place angle bridges on top of supports. Ensure that notches in angle bridges fit over tops of Double Super Supports. See Fig. 14.

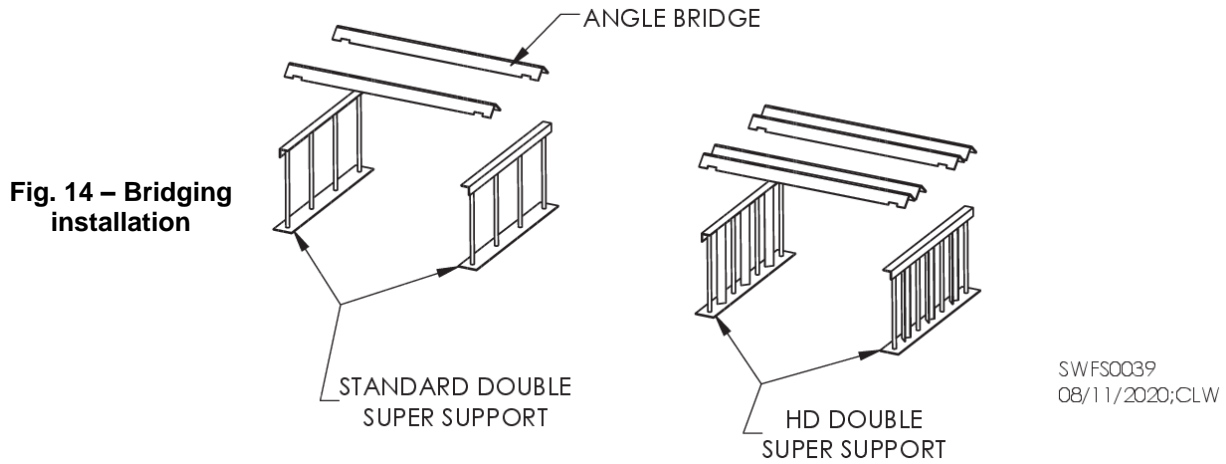

NOTE: P5115 angle (44" long) for an 18" span must be cut in half at center. Use slot as a guide as shown in Fig. 15. Each P5115 will yield two individual angle bridges. P5113 angles (31" long) for a 26" span do NOT need to be cut.

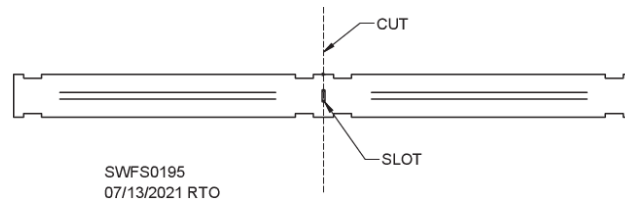

Fig. 15 – Cutting P5115 angle

Fig. 16 shows views of bridging under Hawk Cut plank. Bridging must be at center of each plank unless two bridges are required, in which case they must be positioned as shown.

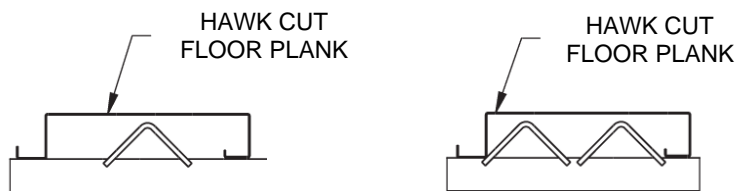

Fig. 16 – Centering bridges under planks

Table below shows part numbers of bridge kits, Standard Double Super Supports and Heavy Duty Double Super Supports.

DESCRIPTION	PART #
Bridge Kit, 1 P5115 Angle Bridge	P5110
Bridge Kit, 1 P5113 Angle Bridge	P5111
Standard Double Super Support, 13-1/4"	P5005
Standard Double Super Support, 17"	P5007
Heavy Duty Double Super Support, 13-1/4"	P50051
Heavy Duty Double Super Support, 17"	P50071

Bridge kit and support part numbers

Determining Need for Bridging

If applicable table for type of supports used under floor says supports should be placed closer than allowed by width of sump gate and/or unload system, then bridging is needed to support floor planks at sump(s) and/or along unload auger or conveyor. It is OK to use a Double Super Support in place of a SuperWave or Z-Post support to get closer to unload system without interference.

Determining Number of Bridges per Floor Plank

Use tables below to determine if one or two bridges are required per floor plank. If two are required, then Heavy Duty Double Super Supports must be used.

NOTE: When using Sukup Office, number of bridge kits and number and type of Double Super Supports (Standard or Heavy Duty) will be specified after entering type of unload system, bin diameter and height, type of flooring and supports. Number of Double Super Supports to go in front of fans will also be specified.

18" SPAN (P5115 BRIDGE)			
Single bridge per plank & Standard Double Super Supports		Two bridges per plank & HD Double Super Supports	
≤ 48' dia.	54-78'	≤ 48' dia.	54-78'
21	19	No limit	No limit

P5115 bridge limits for 7" Hawk Cut by bin diameter & number of rings (shaded)

26" SPAN (P5113 BRIDGE)			
Single bridge per plank & Standard Double Super Supports		Two bridges per plank & HD Double Super Supports	
≤ 48' dia.	54-78'	≤ 48' dia.	54-78'
10	8	19	18

P5113 bridge limits for 7" Hawk Cut by bin diameter & number of rings (shaded)

Example:

- An 8" Sweepway in a 42' dia., 7-ring bin with Hawk Cut flooring and SuperWave supports requires support spacing of 21", according to table on Page 10. Since center sump gate is 23-1/2" wide (See upper table on Page 17), neither SuperWaves nor Double Super Supports can be used at center sump gate opening, so bridging is needed above void for sump gate. Since unload is 8" wide, SuperWaves can be used on one side of unload tube at normal 21" spacing. On clutch rod side, SuperWave would interfere with rod, so Double Super Supports must be used between unload tube and clutch rod. See Fig. 17. **NOTE:** See Fig. 21 for widths of SuperWave, Z-Post and Double Super Supports.

NOTE: Supports used for bridging do not diminish need to abide by required spacing of other supports used under floor.

See drawings and tables on following pages for typical placement of Double Super Supports and bridging under flooring depending on type of unload system and floor supports used in bin.

NOTE: Remember that Z-Posts are staggered as shown in Fig. 5. Spacing shown in following tables is "A" spacing.

Supporting Floor over Sweepway

Fig. 17 shows typical use of Double Super Supports for Sweepway unload system with SuperWave Supports at 22" spacing. Drawing also shows bridging over center sump gate.

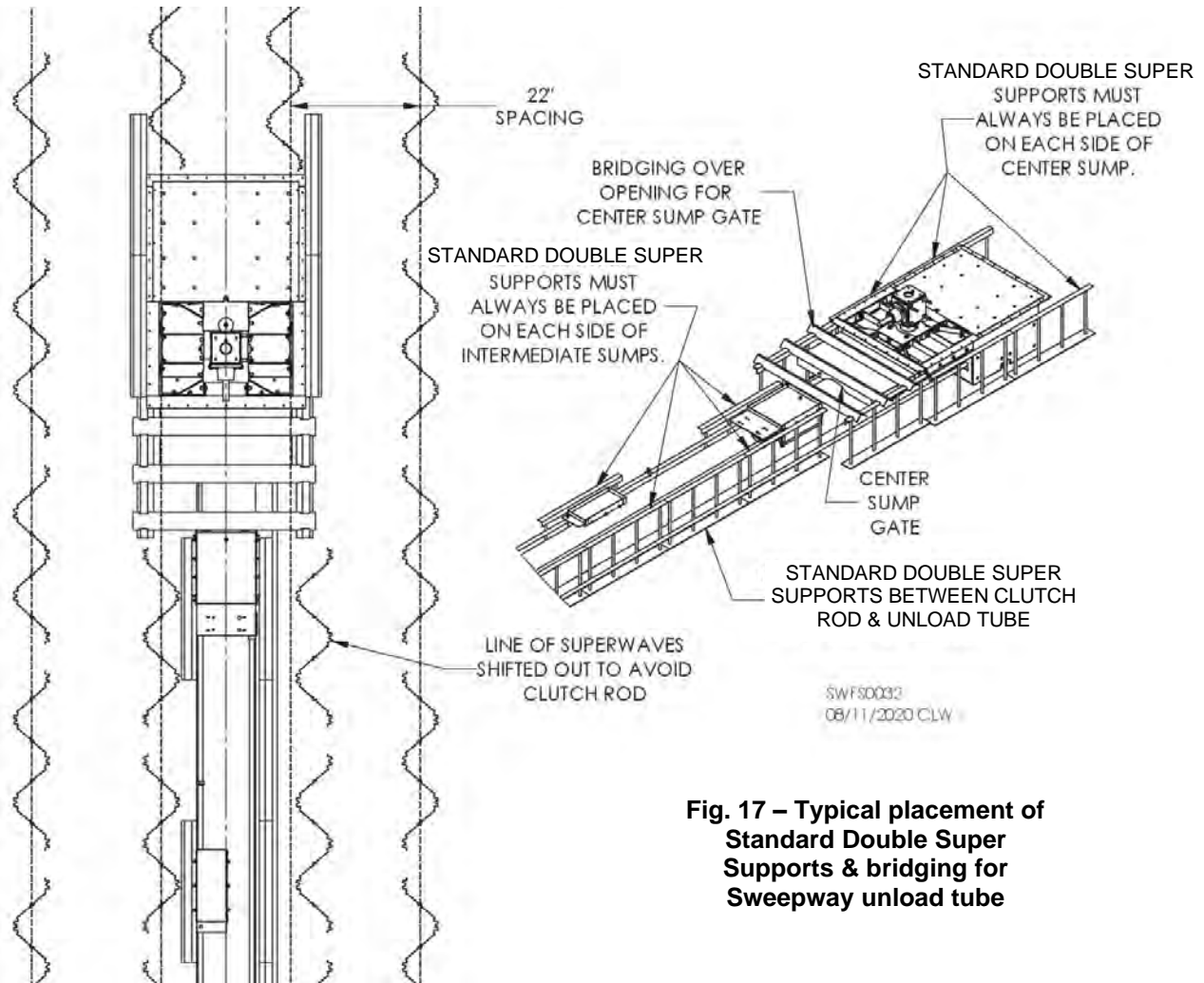

Fig. 17 – Typical placement of Standard Double Super Supports & bridging for Sweepway unload tube

Table below shows when to install Standard Double Super Supports on either side of center sump gate opening without bridging, depending on tube diameter, type of floor support used in bin, and support spacing.

UNLOAD DIA.	TYPE OF FLOOR SUPPORT	
	SUPERWAVES	Z-POSTS
6"	18" to 22"	36" to 44"
8"	24" to 30"	48" to 60"
10"	24" to 30"	48" to 60"

Table below shows when to use bridging over center sump gate opening, depending on tube diameter, type of floor support used in bin, and support spacing.

UNLOAD DIA.	TYPE OF FLOOR SUPPORT	
	SUPERWAVES	Z-POSTS
6"	<18"	<36"
8"	<24"	<48"
10"	<24"	<48"

Supporting Floor over Unload System

Table below shows when to install a line of Standard Double Super Supports between clutch rod and unload tube, depending on tube diameter, type of floor support used in bin, and support spacing.

UNLOAD DIA.	TYPE OF FLOOR SUPPORT	
	SUPERWAVES	Z-POSTS
6"	12" to 20"	24" to 40"
8"	14" to 22"	28" to 44"
10"	16" to 24"	32" to 48"

Table below shows when to install a line of Standard Double Super Supports on each side of unload tube without bridging, depending on tube diameter, type of floor support used in bin, and support spacing.

UNLOAD DIA.	TYPE OF FLOOR SUPPORT	
	SUPERWAVES	Z-POSTS
6"	8" to 12"	16" to 24"
8"	10" to 14"	20" to 28"
10"	12" to 16"	24" to 32"

Table below shows when to use bridging over unload tube, depending on tube diameter, type of floor support used in bin, and support spacing.

UNLOAD DIA.	TYPE OF FLOOR SUPPORT	
	SUPERWAVES	Z-POSTS
6"	<8"	<16"
8"	<10"	<20"
10"	<12"	<24"

Supporting Floor over U-Trough

Fig. 18 shows typical use of Double Super Supports for U-Trough unload system with SuperWave Supports at 22" spacing. Drawing also shows bridging over trough if spacing of SuperWave or Super Supports is less than 16" or if spacing of Z-Posts is less than 32".

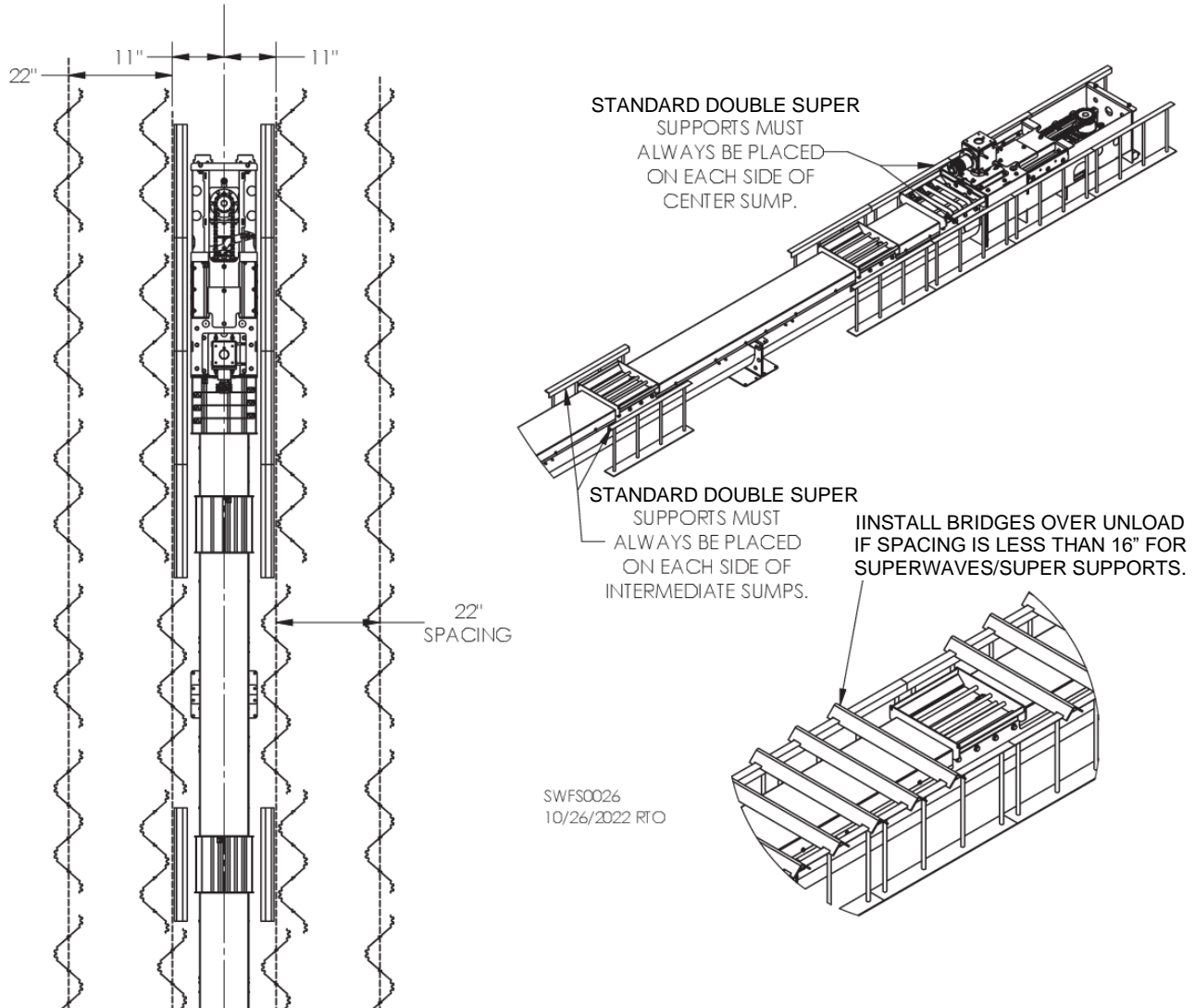

Fig. 18 – Typical placement of Standard Double Super Supports and bridging for U-Trough

If using SuperWave Supports, install a line of Double Super Supports on each side of trough if required floor support spacing (from applicable table) is 16" to 20". If using Z-posts, install a line of Double Super Supports on each side of unload if required floor support spacing (from applicable table) is 32" to 40".

If using SuperWave Supports, use bridging if required spacing (from applicable table) is less than 16". If using Z-posts, use bridging if required spacing (from applicable table) is less than 32".

Supporting Floor over Drag Conveyor

Fig. 19 shows typical use of Double Super Supports and bridging along drag conveyor with SuperWave Supports at 22" spacing.

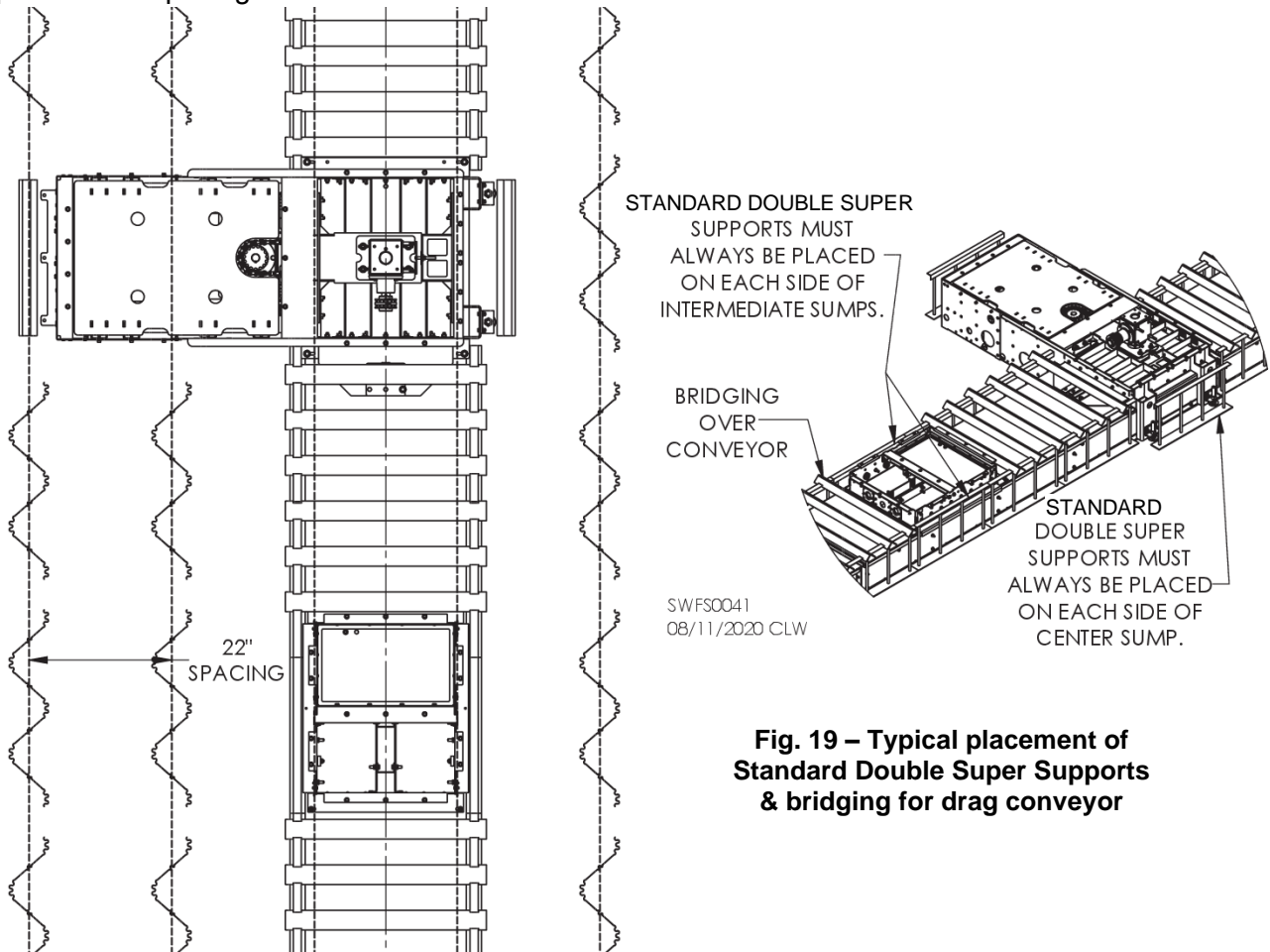

Fig. 19 – Typical placement of Standard Double Super Supports & bridging for drag conveyor

Table below shows when to install a line of Standard Double Super Supports without bridging on each side of conveyor, depending on conveyor width, type of floor support used in bin, and support spacing.

CONVEYOR WIDTH	TYPE OF FLOOR SUPPORT	
	SUPERWAVES	Z-POSTS
12"	21" to 24"	42" to 48"
16"	25" to 28"	50" to 56"
21"	30" to 33"	60" to 66"

Table below shows when to use bridging over conveyor, depending on conveyor width, type of floor support used in bin, and support spacing.

CONVEYOR WIDTH	TYPE OF FLOOR SUPPORT	
	SUPERWAVES	Z-POSTS
12"	<21"	<42"
16"	<25"	<50"
21"	<30"	<60"

Supporting Floor over Chain Loop Conveyor

Fig. 20 shows typical use of Double Super Supports for Chain Loop Conveyor unload system with SuperWave Supports at 18" spacing. Drawing also shows bridging over center sump gate.

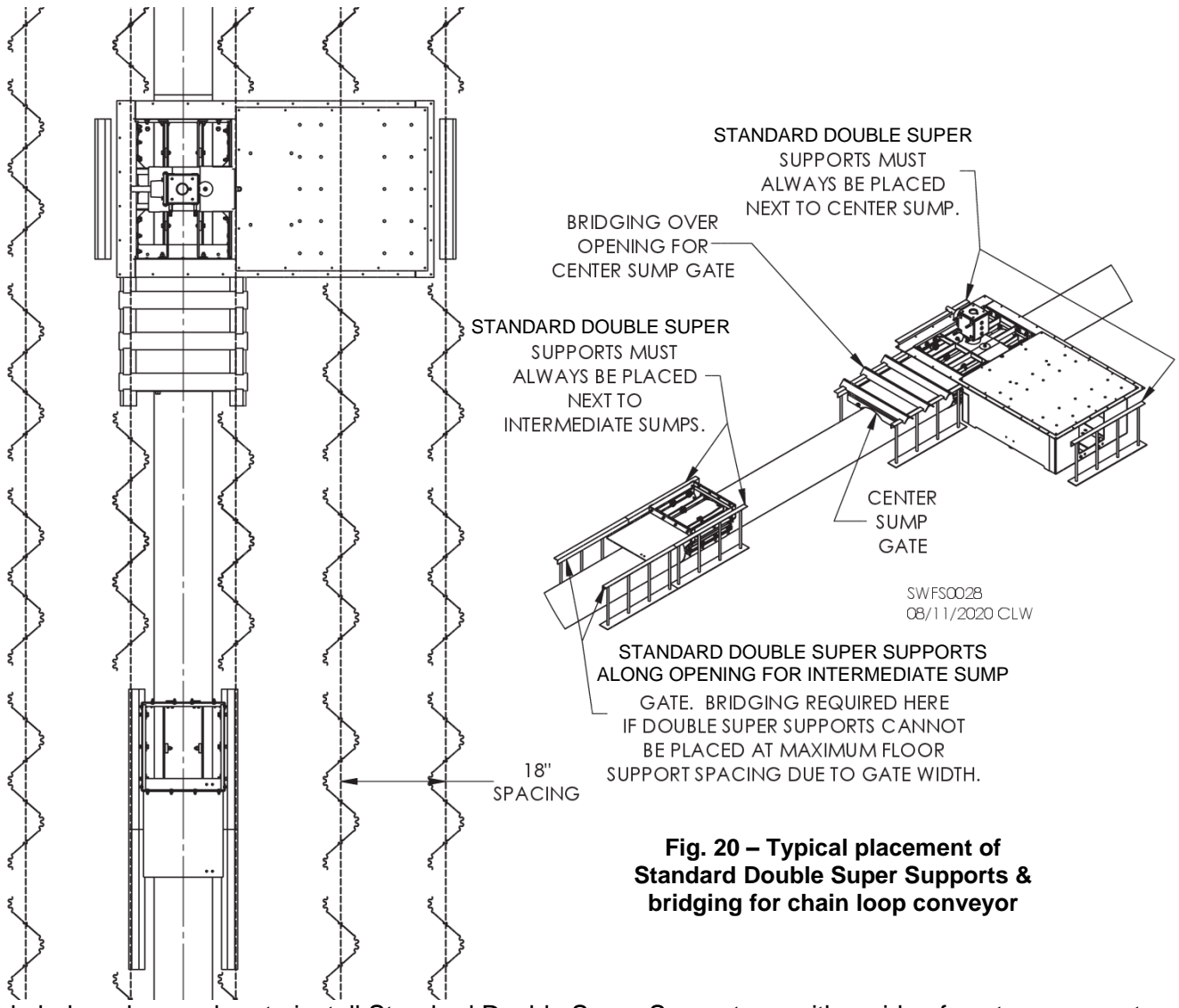

Fig. 20 – Typical placement of Standard Double Super Supports & bridging for chain loop conveyor

Table below shows when to install Standard Double Super Supports on either side of center sump gate opening without bridging, depending on tube diameter, type of floor support used in bin, and support spacing.

UNLOAD DIA.	TYPE OF FLOOR SUPPORT	
	SUPERWAVES	Z-POSTS
8"	19" to 22"	38" to 44"
10"	19" to 22"	38" to 60"
12"	23" to 26"	46" to 52"

Table below shows when to use bridging over center sump gate opening, depending on tube diameter, type of floor support used in bin, and support spacing.

UNLOAD DIA.	TYPE OF FLOOR SUPPORT	
	SUPERWAVES	Z-POSTS
8"	<19"	<38"
10"	<19"	<38"
12"	<23"	<46"

Supporting Floor over Unload System

Table below shows when to use bridging over intermediate sump gate opening, depending on tube diameter, type of floor support used in bin, and support spacing.

UNLOAD DIA.	TYPE OF FLOOR SUPPORT	
	SUPERWAVES	Z-POSTS
8"	<17"	<34"
10"	<17"	<34"
12"	<19"	<38"

Table below shows when to install a line of Standard Double Super Supports on each side of unload tube without bridging, depending on tube diameter, type of floor support used in bin, and support spacing.

UNLOAD DIA.	TYPE OF FLOOR SUPPORT	
	SUPERWAVES	Z-POSTS
8"	11" to 14"	22" to 28"
10"	13" to 16"	26" to 32"
12"	15" to 18"	30" to 36"

Table below shows when to use bridging over unload tube, depending on tube diameter, type of floor support used in bin, and support spacing.

UNLOAD DIA.	TYPE OF FLOOR SUPPORT	
	SUPERWAVES	Z-POSTS
8"	<11"	<20"
10"	<13"	<26"
12"	<15"	<30"

General Advice

If unload system and all open sump gates fit between floor supports that are spaced as required in this manual, then no other supports are needed to support flooring over unload system.

If unload system and/or an open sump gate will not fit between floor supports spaced as required in this manual, a Double Super Support may be used in place of interfering SuperWave or Z-Post support.

If a Double Super Support substituted for a SuperWave or Z-Post support would interfere with an unload system or sump gate, bridging is required.

If bridging along unload system is required, check lower table on Page 19 to see if one bridge with Double Super Supports is OK, or if two bridges with Heavy Duty Double Super Supports are needed for each floor plank.

Fig. 21 shows SuperWave and Z-Post floor supports' width of 6". When properly placed on support lines there is 3" on each side. If there will be interference with unload system or a sump gate, a narrower Double Super Support (1-1/4" wide at top) can be substituted.

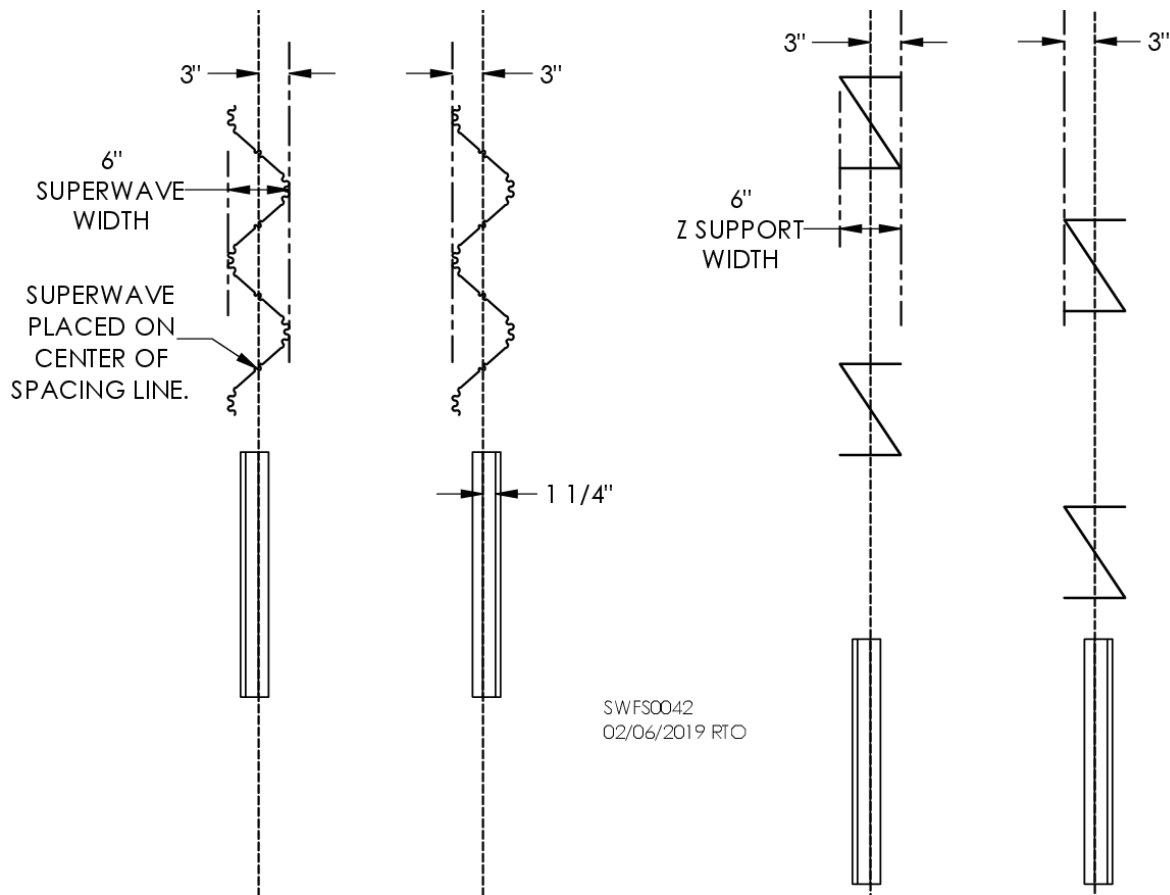

Fig. 21 – Widths of SuperWave, Z-Post and Double Super Supports

SUPPORTING FLOOR FOR PARKED PADDLE SWEEPWAY

If a Paddle Sweepway will be installed in bin, parking stands are required to support sweep in its parked position. These stands are in addition to any bridging required for supporting floor over bin unload system.

See Fig. 22 for type of parking stands to use under Paddle Sweepway parking legs depending on type of unload system used, and see applicable layout drawing in Paddle Sweepway Manual L14359F. Layouts are based on standard Sukup unloads. If using a non-standard layout or unload system from a different manufacturer, support leg locations and bridging locations may need to be adjusted.

IMPORTANT: Position stands precisely so that sweep support legs land on parking stands. Cut floor planks at each stand location so floor edges are as close to stand as possible and are adequately supported.

NOTICE: Ensure Paddle Sweepway support parking legs miss sumps to avoid damage to sweep.

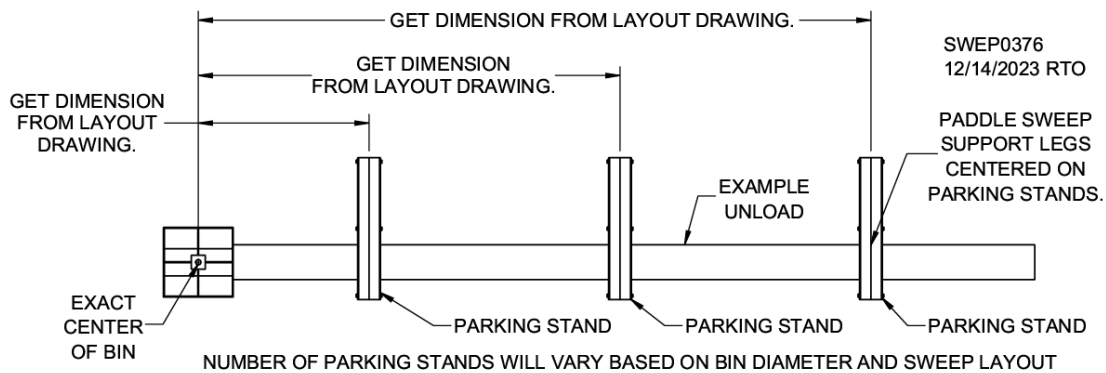
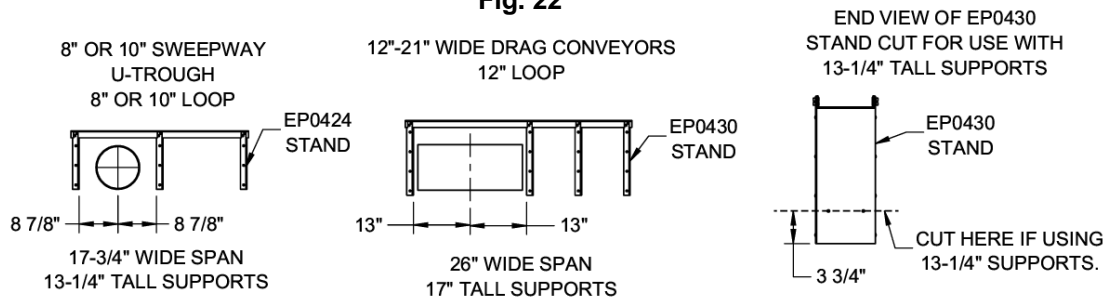

Fig. 22



See Fig. 23 for installation of parking stands over unload system. Floor supports (not shown) may need to be relocated or cut to avoid interference with stands. If needed, slide in Double Super Supports. It is critical that floor support spacing specified in this manual is maintained, and that each floor plank is supported.

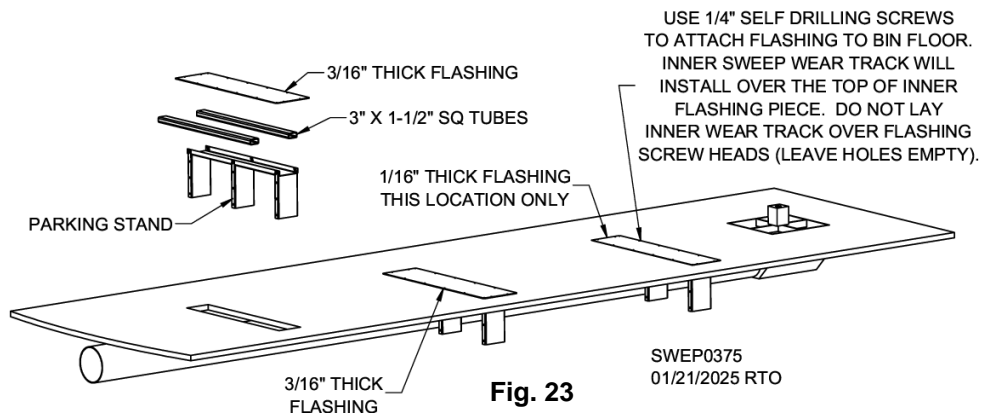

Fig. 23

Install two 3" x 1-1/2" square tubes on each parking stand, then cover each stand with supplied flashing. See Fig. 23. Stand closest to center of bin uses thinner (1/16") flashing. All other flashing should be 3/16" thick. In either case, secure flashing to flooring with 1/4" self-drilling screws.

SUPPORTING FLOOR IN FRONT OF FAN

Place four Double Super Supports at each fan transition to minimize airflow resistance. Exact placement will vary depending on fan location and floor support spacing. Use Double Super Supports to maintain floor support spacing and comply with plank overhang limits. Fig. 24 shows Double Super Supports used instead of SuperWave supports. Placement of Double Super Supports with Z-Posts will be similar.

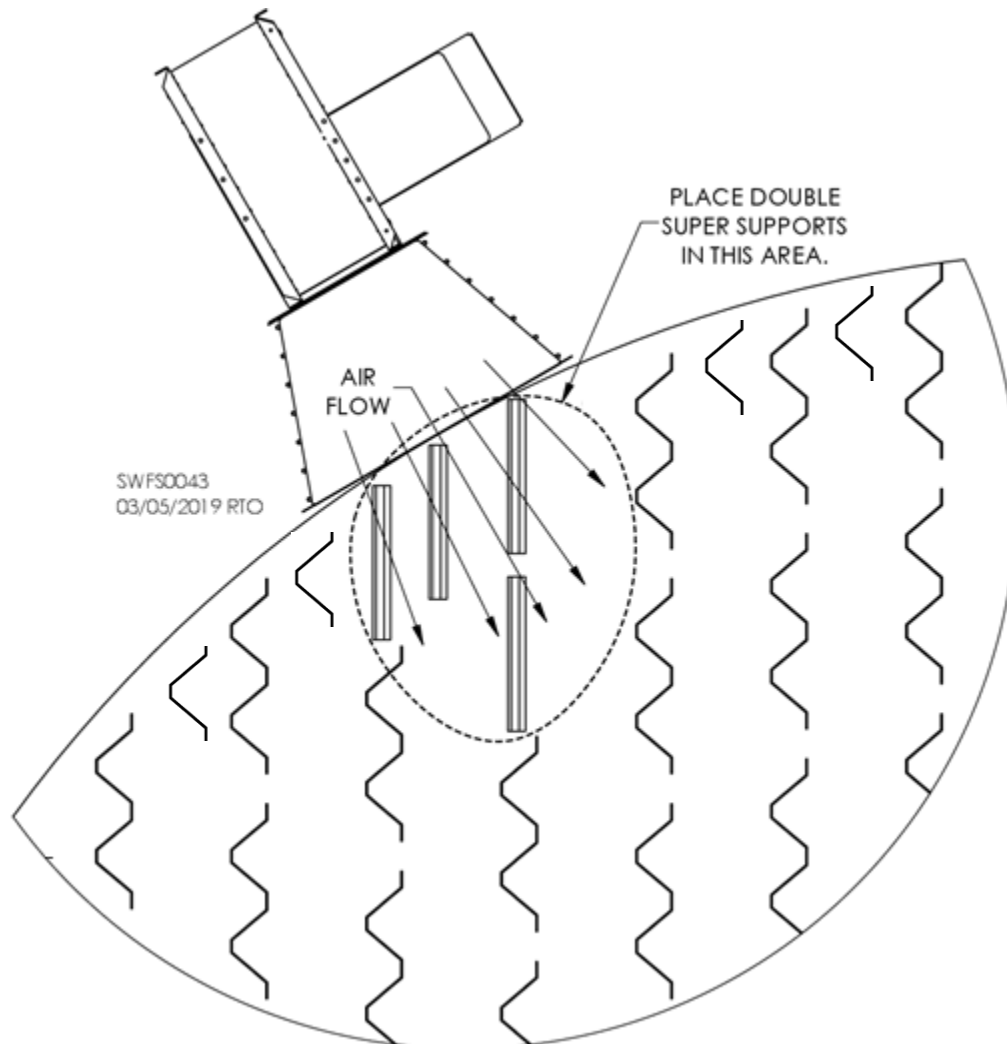

Fig. 24 – Supporting floor in front of fan

SUPPORTING FLOOR PLANKS AT SPLITS

Maximum unsupported overhang of Hawk Cut floor plank at split is 7" no matter which type of supports are used in bin. If either floor plank at split has a longer unsupported overhang, additional supports will be needed. Fig. 25 shows additional line of SuperWave supports under plank split lines.

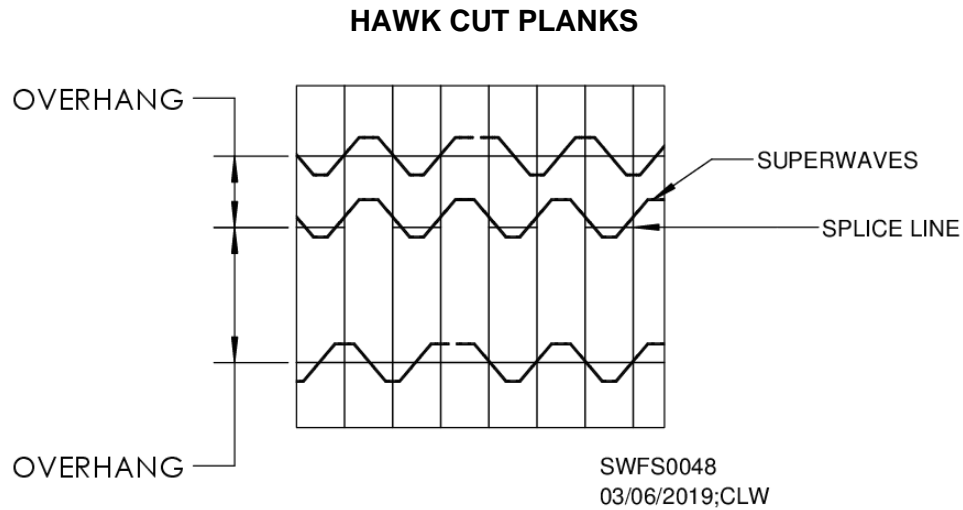

Fig. 25 – Supporting floor planks at splits

INSTALLING SPLIT PLANKS AT CENTER SUMP

To limit use of short pieces of flooring that can be difficult to support, follow instructions below for split-plank floors in bins 36' to 75' dia. Split lines on each side of center sump will be farther apart than original split lines. Beginning at center sump, cut planks as follows:

1. Cut "A" plank in half. Use halves as outermost segments of split plank. See Fig. 26.
2. Measure distances between sump and inner ends of "A" planks. Cut "B" plank to fit between sump and ends of "A" plank segments just installed.
3. For next plank, cut "B" plank in half. Use halves as outermost segments of split plank.
4. Measure distances between sump and inner ends of "B" planks. Cut "A" plank to fit between sump and ends of "B" plank segments just installed.
5. Repeat Steps 1-4 until past sump, then install planks as usual.

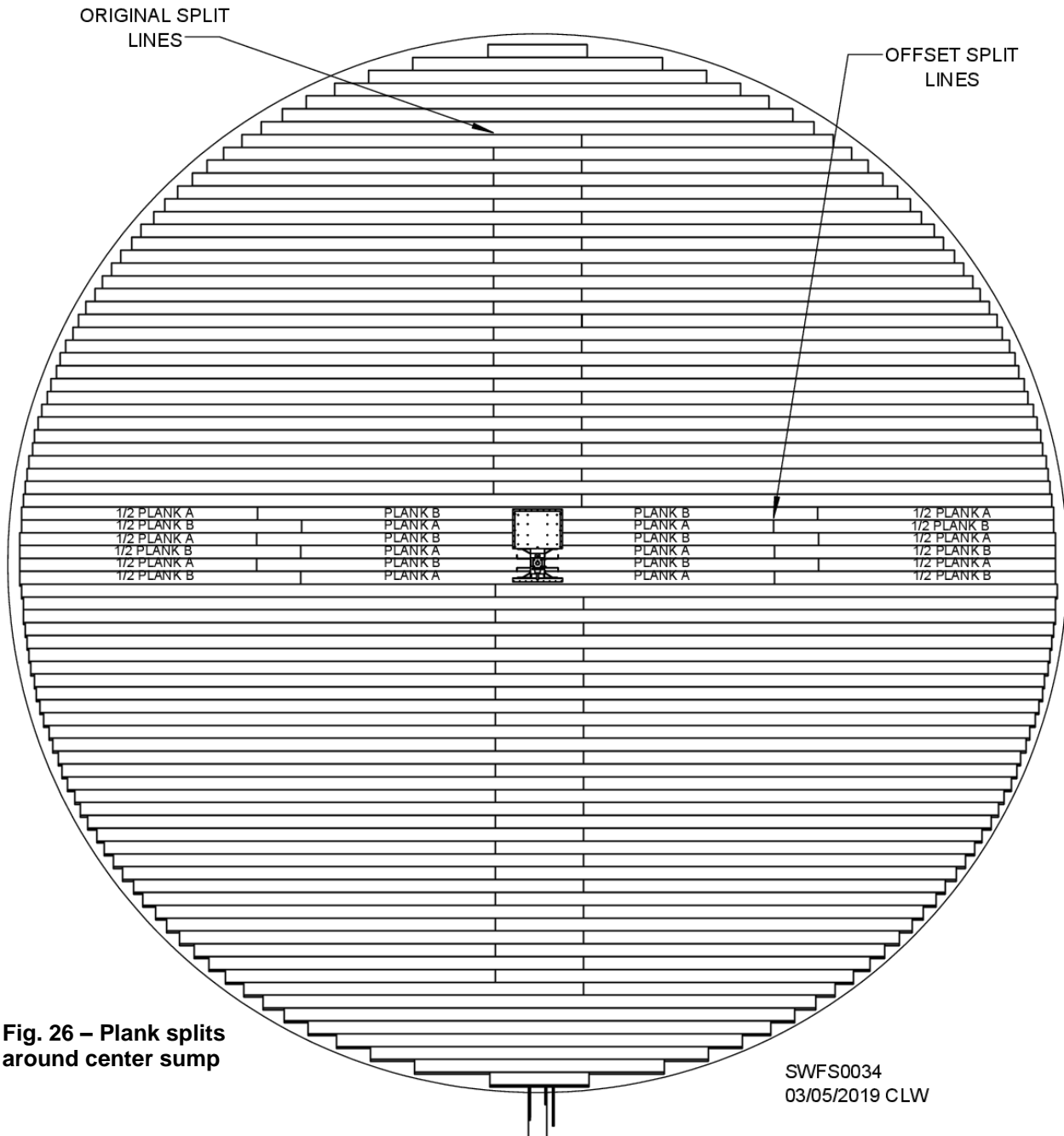

Fig. 26 – Plank splits around center sump

SWFS0034
03/05/2019 CLW

FLOOR PLANK SPLICING

If bin floor plank is made up of two or more pieces, each joint must be spliced.

Using self-drilling screws, join two pieces of floor plank by fastening perforated splice as shown in Fig. 27.

NOTICE: If Paddle Sweepway will be used in bin, do not install splice screws in paths of sweep's support legs. This will reduce potential for catching, which could damage sweep legs or stop sweep. Install screws as close as possible to suggested locations.

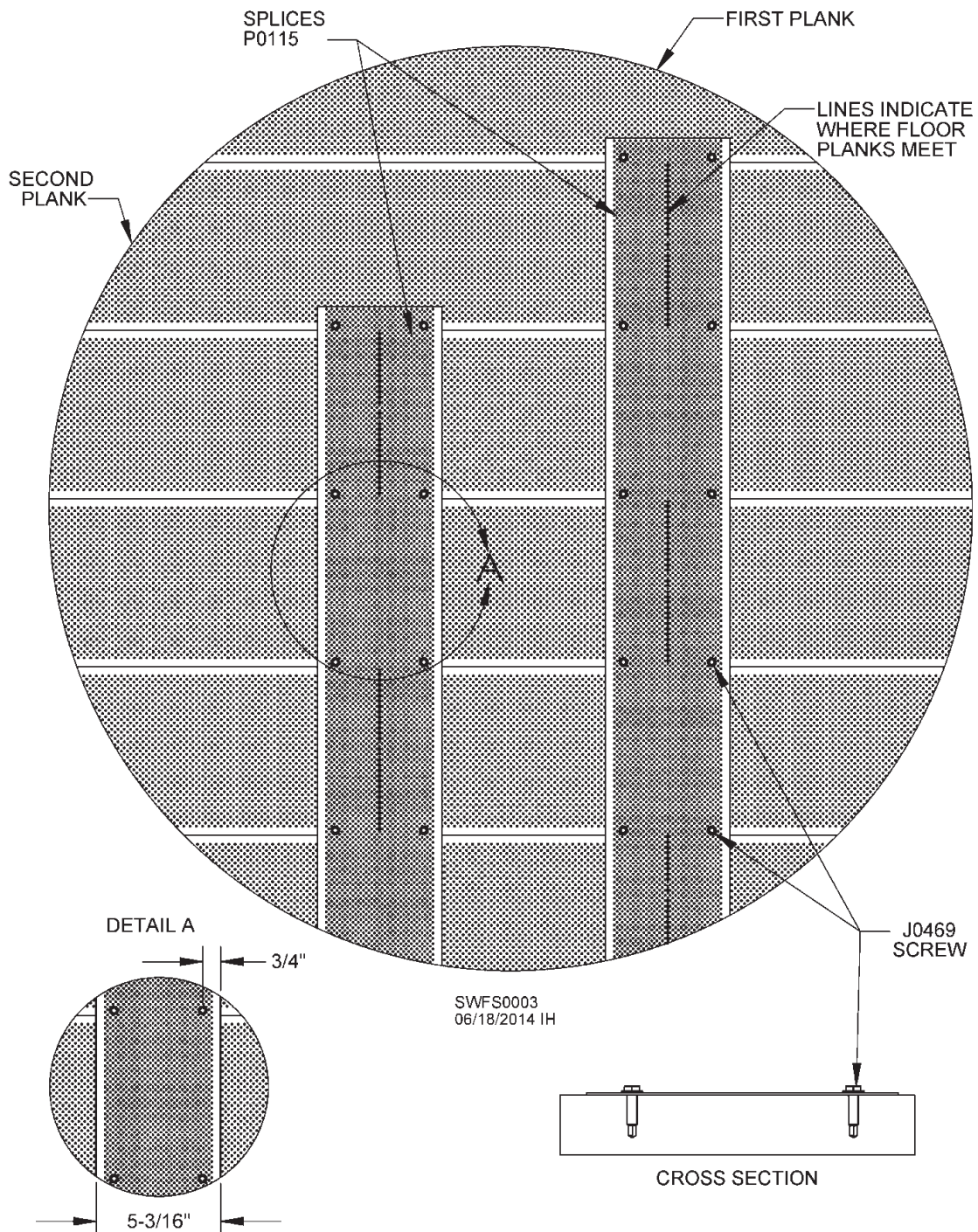

Fig. 27 – Splicing floor planks

FLASHING INSTALLATION

If sweep auger will be used in bin, flashing must be overlapped as shown in Fig. 28 so that sweep wheel will "climb up" flashing sections as sweep travels clockwise around bin. This will prevent wheel from catching on edges of flashing. Reverse overlap if sweep will run counterclockwise.

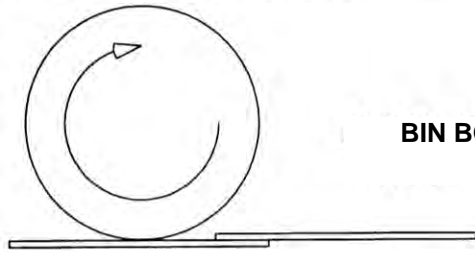
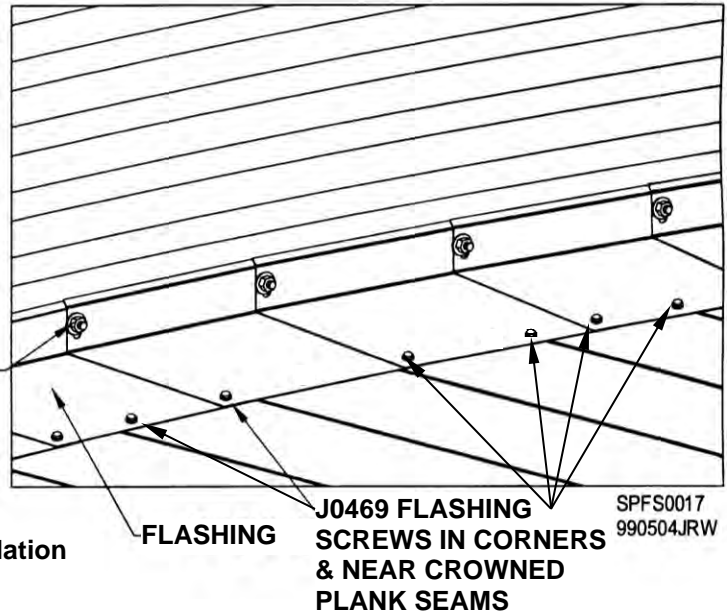

Fig. 28 – Flashing installation



Install a #10 x 3/4" flashing screw (J0469) at corner of each piece of flashing so screw goes through two pieces of flashing and into flooring. See Fig. 28. Install an additional screw if two crowned planks meet more than 2" from seam between flashing pieces.

See Fig. 29 or Fig. 30 to properly bolt flashing to side of bin. Use pre-punched plenum holes if present. If not, drill holes in sidewall. **IMPORTANT:** Use 3/8" bolts. **NOTE:** If flashing was ordered pre-punched for Airways, pieces that are not pre-punched go under bin door.

Fig. 29 – Bolting on hill

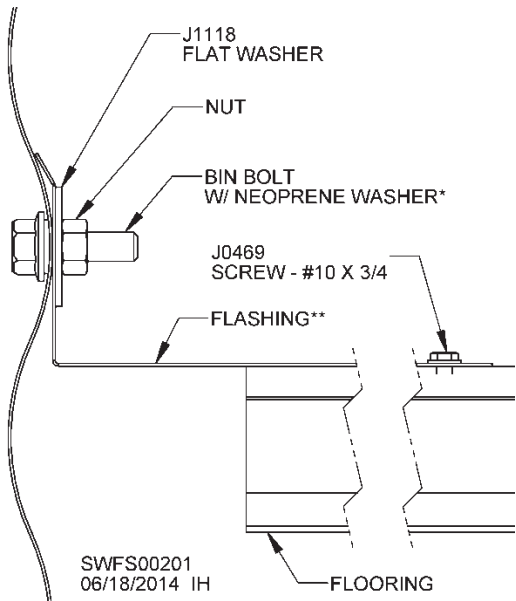
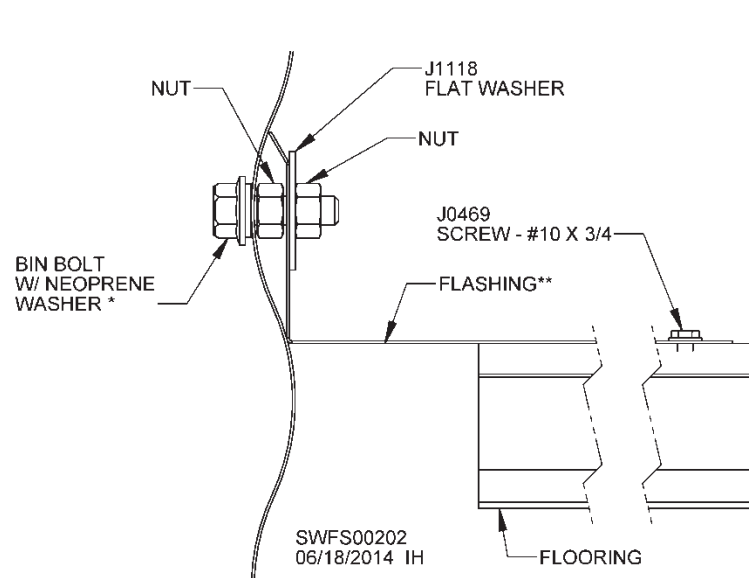

Fig. 30 – Bolting in valley



*Bin bolts with neoprene washers not included with flashing

Layout & Location of Floor Planks

Locating & Installing Floor Planks

Included with each of the following floor plank layouts are instructions for locating planks. Please read them carefully before beginning floor assembly.

See applicable floor support table for spacing and total number of supports based on bin eave height. Table for SuperWave Supports is on Page 10. Table for Z-Post Supports is on Page 13; and table for Super Supports is on Page 16.

Place supports under each plank and install according to applicable instructions.

Floors in 36', 42' and 48' dia. bins can be ordered split or non-split. Floors in bins larger than 48' in diameter are all split-plank floors.

The following notes apply to split-plank floors in bins 36' diameter and larger:

- Lengths of split pieces are shown for each plank number.
- Locations of end-to-end seams in split planks must alternate as shown in plank layout drawing for bin. See Page 30 for moving split lines farther from center sump.
- See Page 31 for plank splicing instructions.

There is only one plank "0" and two of all others (one on each side of centerline) for floors in bins 15', 21', 27', 33', 36' (split), 48' (split & non-split), 60', 75' and 78'diameter:

LAYOUT & LOCATION OF FLOOR PLANKS

15' DIA. BIN PLANK LAYOUT

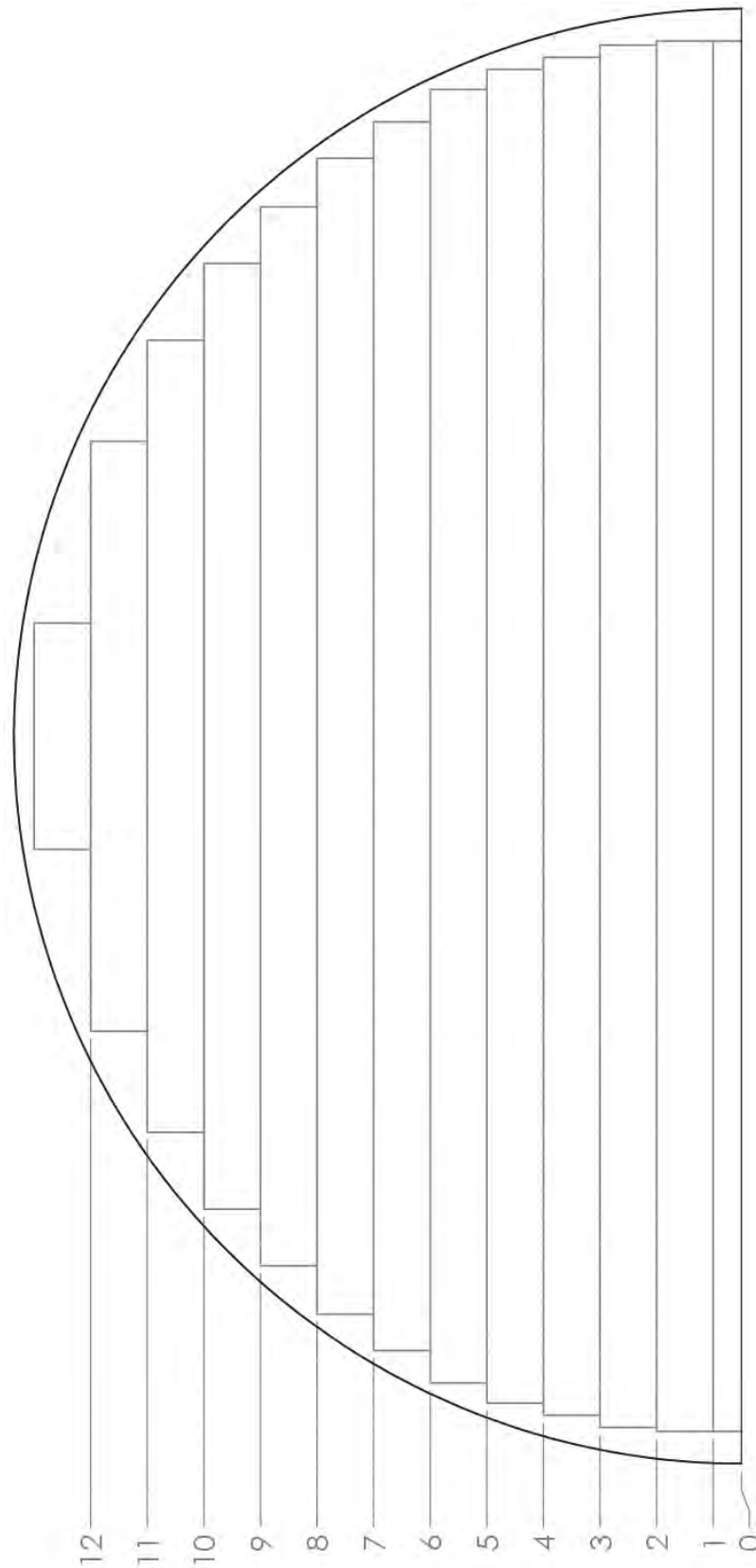

SWFS0169
06/20/2019 CLW

Layout & Location of Floor Planks

LOCATING PLANKS FOR 15' DIA. BIN

A 15' floor is shipped in two stacks.

1. Label stacks as shown below by measuring bottom plank of each stack.
2. See layout on previous page. Plank closest to sidewall (Plank 12, measuring 2' 4") is starter plank.
3. Lay out planks of Stack 1. Install in descending order from Plank 12 to Plank 0, then open Stack 2 and work in ascending order on other side of bin.

See Page 33 for important notes.

15' FLOOR

Stack 1		Stack 2	
Plank #	Length	Plank #	Length
Top of Stack			
12	2' 4"	12	2' 4"
11	6' 1"	11	6' 1"
10	8' 2"		
		10	8' 2"
9	9' 9"	9	9' 9"
8	10' 11"		
		8	10' 11"
7	11' 11"	7	11' 11"
6	12' 8"		
		6	12' 8"
5	13' 4"	5	13' 4"
4	13' 9"		
		4	13' 9"
3	14'	3	14"
2	14' 3"		
		2	14' 3"
1	14' 4"	1	14' 4"
0	14' 4"		
Bottom of Stack			

18' DIA. BIN PLANK LAYOUT

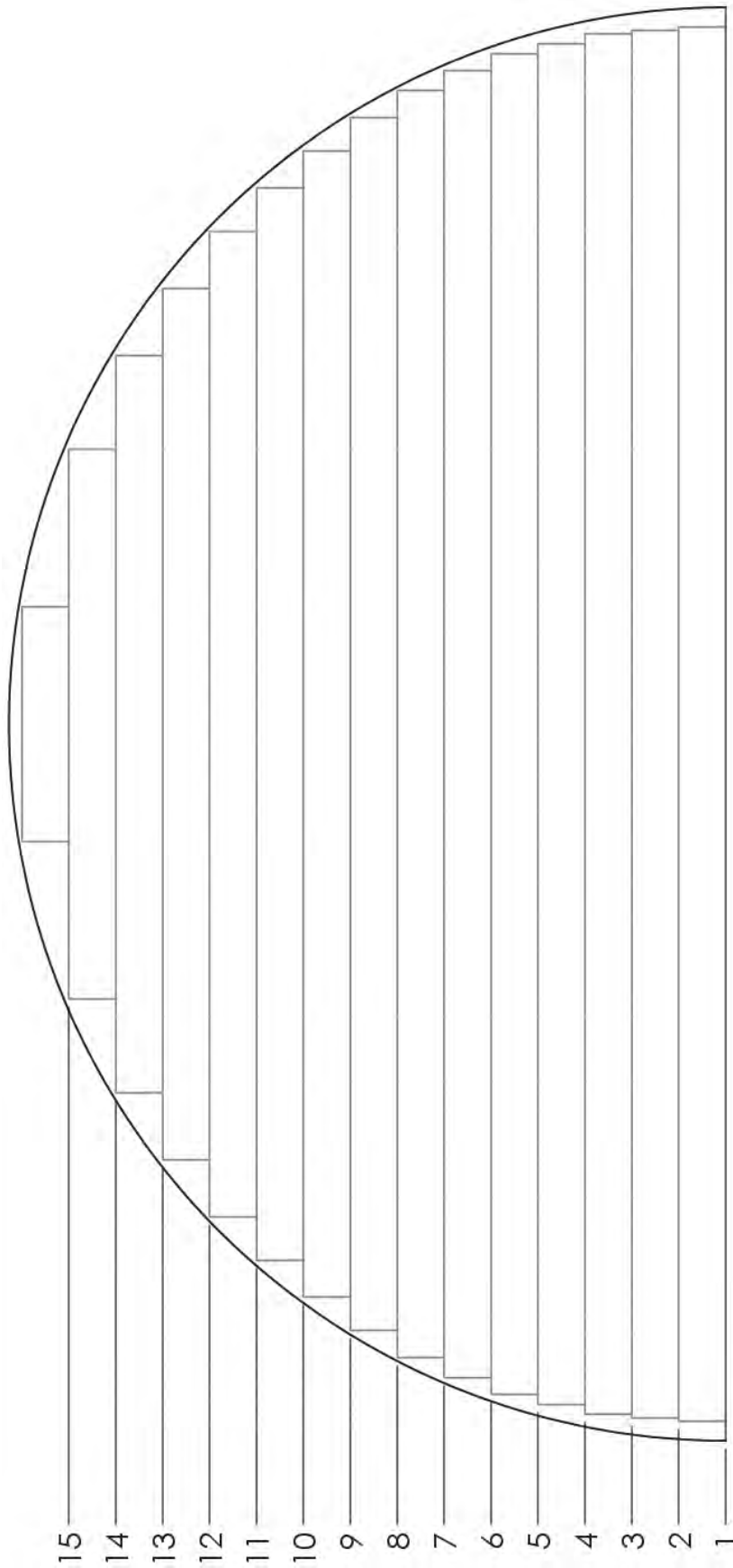

SWFS0170
06/24/2019 CLW

LOCATING PLANKS FOR 18' DIA. BIN

An 18' floor is shipped in two identical stacks.

See layout on previous page. Plank closest to sidewall (Plank 15, measuring 2' 11") is starter plank.

Lay out planks of Stack 1. Install in descending order from Plank 15 to Plank 1, then open Stack 2 and work in ascending order on other side of bin.

See Page 33 for important notes.

18' FLOOR

Stacks 1 & 2
Plank # Length

Top of Stack

15	2' 11"
14	6' 10"
13	9' 2"
12	10' 10"
11	12' 3"
10	13' 4"
9	14' 3"
8	15' 1"
7	15' 9"
6	16' 3"
5	16' 8"
4	16' 11"
3	17' 2"
2	17' 3"
1	17' 4"

Bottom of Stack

21' DIA. BIN PLANK LAYOUT

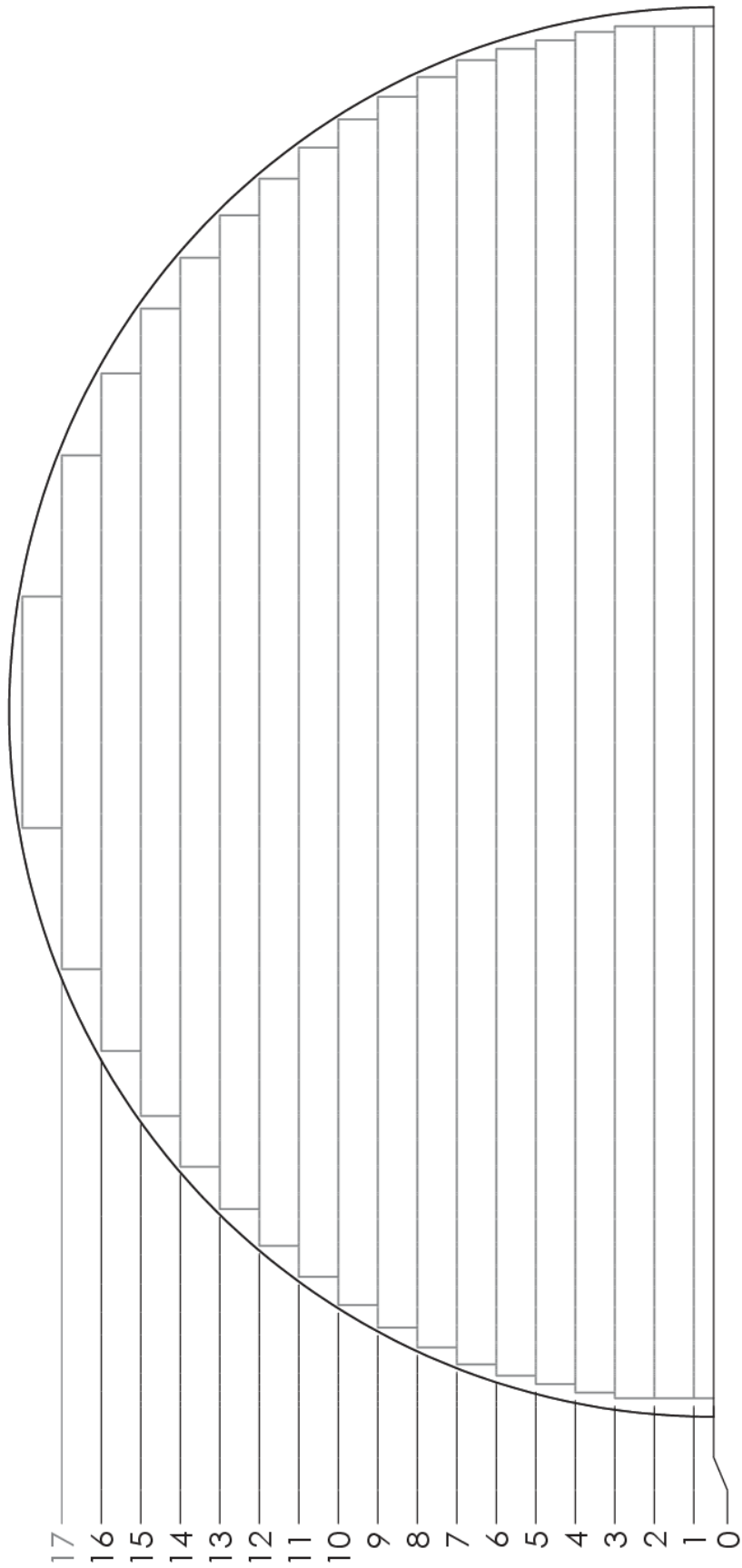

SWFS0171
06/24/2019 CLW

Layout & Location of Floor Planks

LOCATING PLANKS FOR 21' DIA. BIN

A 21' floor is shipped in two stacks.

1. Label stacks as shown below by measuring top plank of each stack.
2. See layout on previous page. Plank closest to sidewall (Plank 17, measuring 3' 5") is starter plank.
3. Lay out planks of Stack 1. Install in descending order from Plank 17 to Plank 0, then open Stack 2 and work in ascending order on other side of bin.

See Page 33 for important notes.

21' FLOOR

Stack 1		Stack 2	
Plank #	Length	Plank #	Length
Top of Stack			
13	13' 5"	15	10'
12	14' 8"	14	11' 11"
17	3' 5"	17	3' 5"
14	11' 11"	16	7' 7"
11	15' 9"	13	13' 5"
10	16' 8"	12	14' 8"
9	17' 6"	11	15' 9"
8	18' 2"	10	16' 8"
7	18' 9"	9	17' 6"
6	19' 3"	8	18' 2"
5	19' 7"	7	18' 9"
4	19' 10"	6	19' 3"
3	20' 1"	5	19' 7"
2	20' 3"	4	19' 10"
1	20' 3"	3	20' 1"
16	7' 7"	2	20' 3"
15	10'	1	20' 3"
0	20' 3"		
Bottom of Stack			

24' DIA. BIN PLANK LAYOUT

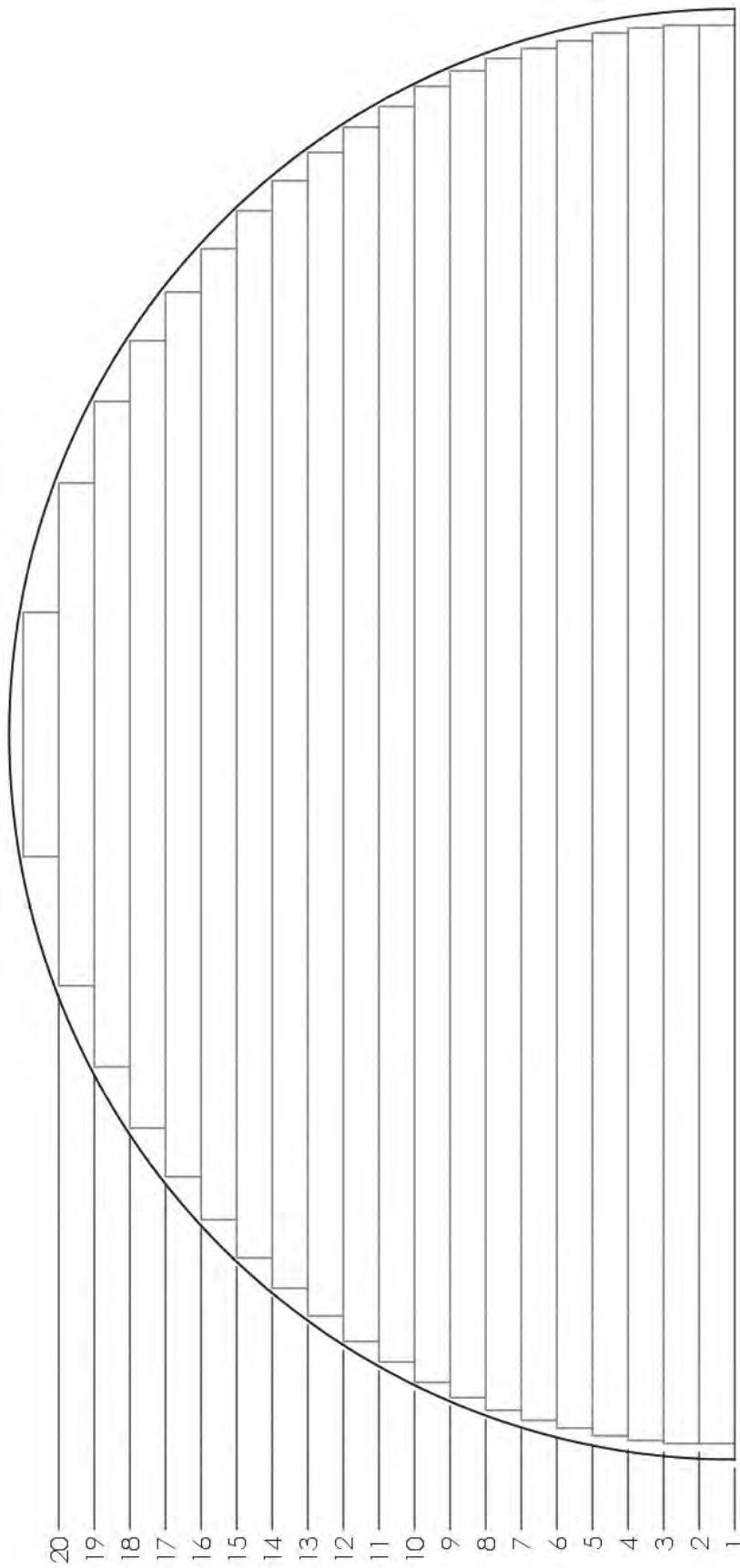

SWFS0172
06/24/2019 CLW

Layout & Location of Floor Planks

LOCATING PLANKS FOR 24' DIA. BIN

A 24' floor is shipped in two identical stacks.

See layout on previous page. Plank closest to sidewall (Plank 20, measuring 4') is starter plank.

Lay out planks of Stack 1. Install in descending order from Plank 20 to Plank 1, then open Stack 2 and work in ascending order on other side of bin.

See Page 33 for important notes.

24' FLOOR

Stacks 1 & 2
Plank #r Length

Top of Stack

16	14' 6"
15	15' 11"

20	4'
17	12' 11"
14	17' 2"

13	18' 2"
12	19' 1"

19	8' 3"
18	10' 11"
11	19' 11"

10	20' 7"
9	21' 3"

8	21' 9"
7	22' 2"

6	22' 6"
5	22' 9"

4	23'
3	23' 2"

2	23' 3"
1	23' 3"

Bottom of Stack

27' DIA. BIN PLANK LAYOUT

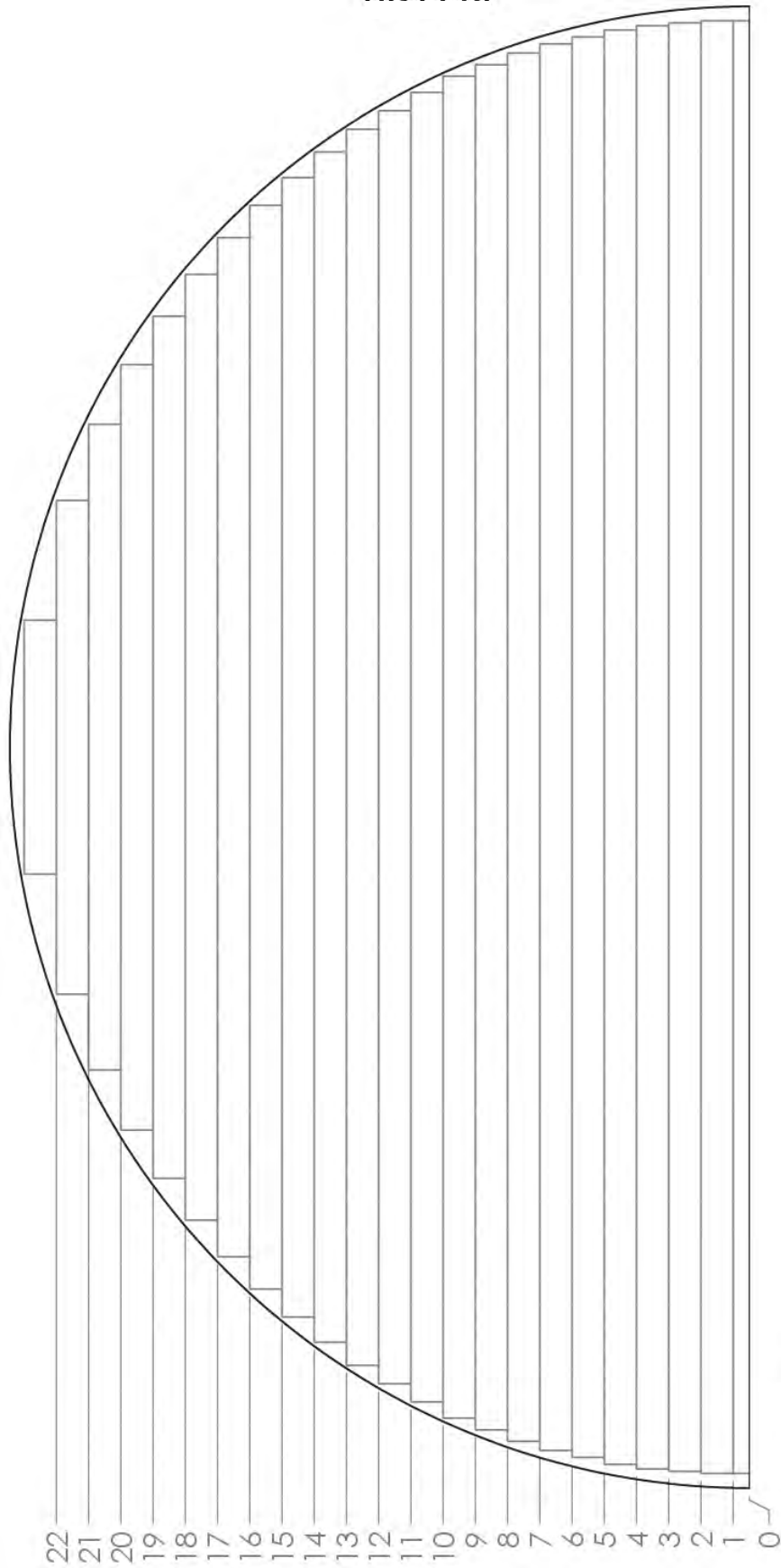

SWFS0173
06/24/2019 CLW

LOCATING PLANKS FOR 27' DIA. BIN

A 27' floor is shipped in two stacks.

1. Label stacks as shown below by measuring top planks of each stack.
2. See layout on previous page. Plank closest to sidewall (Plank 22, measuring 4' 7") is starter plank.
3. Lay out planks of Stack 1. Install in descending order from Plank 22 to Plank 0, then open Stack 2 and work in ascending order on other side of bin.

See Page 33 for important notes.

27' FLOOR

Stack 1		Stack 2	
Plank #	Length	Plank #	Length
Top of Stack			
22	4' 7"	22	4' 7"
21	8' 11"	21	8' 11"
20	11' 8"		
19	13' 10"	20	11' 8"
18	15' 7"	19	13' 10"
17	17' 1"	18	15' 7"
16	18' 5"	17	17' 1"
15	19' 7"	16	18' 5"
14	20' 7"	15	19' 7"
13	21' 6"	14	20' 7"
12	22' 4"	13	21' 6"
11	23'	12	22' 4"
10	23' 8"	11	23'
9	24' 3"	10	23' 8"
8	24' 8"	9	24' 3"
7	25' 1"	8	24' 8"
6	25' 5"	7	25' 1"
5	25' 8"	6	25' 5"
4	25' 11"	5	25' 8"
3	26' 1"	4	25' 11"
2	26' 2"	3	26' 1"
1	26' 3"	2	26' 2"
0	26' 3"	1	26' 3"
Bottom of Stack			

30' DIA. BIN PLANK LAYOUT

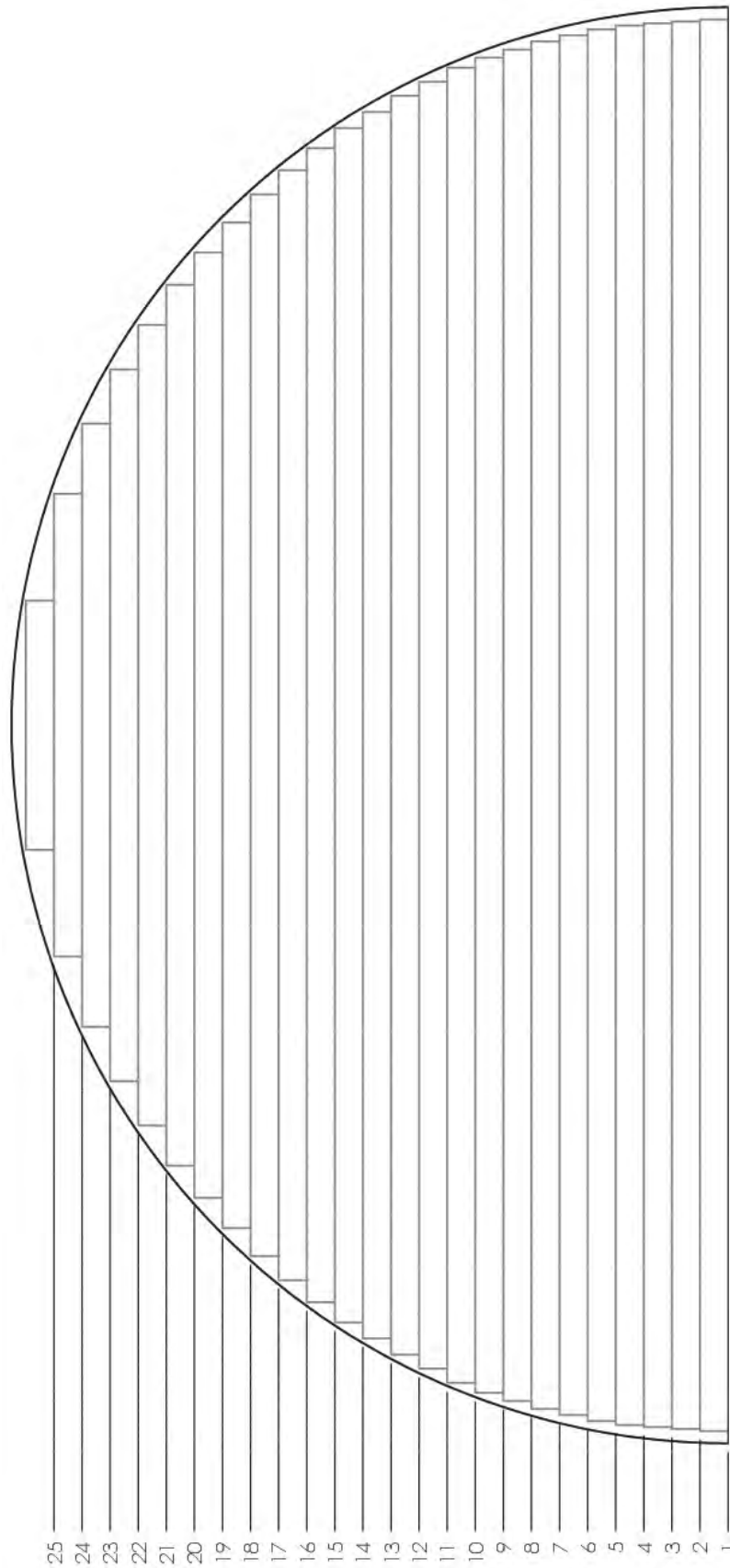

SWFS0174
06/24/2019 CLW

Layout & Location of Floor Planks

LOCATING PLANKS FOR 30' DIA. BIN

A 30' floor is shipped in two identical stacks.

See layout on previous page. Plank closest to sidewall (Plank 25, measuring 5' 2") is starter plank.

Lay out planks of Stack 1. Install in descending order from Plank 25 to Plank 1, then open Stack 2 and work in ascending order on other side of bin.

See Page 33 for important notes.

30' FLOOR

Stacks 1 & 2
Plank # Length

Top of Stack

25	5' 2"
24	9' 7"
23	12' 6"
22	14' 9"
21	16' 7"
20	18' 3"
19	19' 7"
18	20' 10"
17	22'
16	23'
15	23' 11"
14	24' 9"
13	25' 5"
12	26' 1"
11	26' 8"
10	27' 3"
9	27' 8"
8	28'
7	28' 4"
6	28' 7"
5	28' 10"
4	29'
3	29' 1"
2	29' 2"
1	29' 3"

Bottom of Stack

33' DIA. BIN PLANK LAYOUT

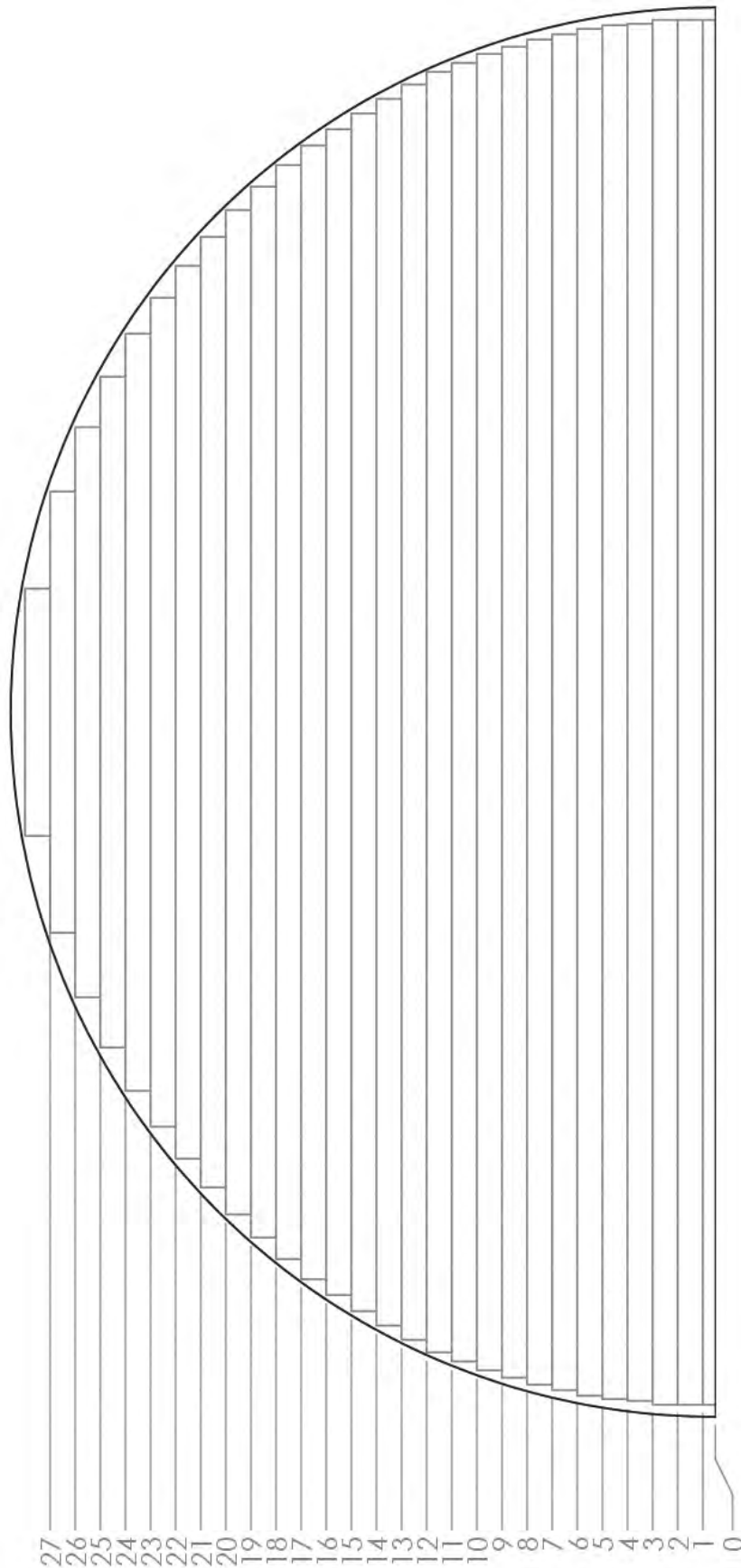

SWFS0175
06/24/2019 CLW

Layout & Location of Floor Planks

LOCATING PLANKS FOR 33' DIA. BIN

A 33' floor is shipped in four stacks.

1. Label stacks as shown below by measuring top plank of each stack.
2. See layout on previous page. Plank closest to sidewall (Plank 27, measuring 5' 9") is starter plank. There is one in Stack 1 and one in Stack 3. It is shortest plank in each stack.
3. Lay out planks of Stacks 1 & 2. Install in descending order from Plank 27 to Plank 0, then work in ascending order on other side of bin.

See Page 33 for important notes.

33' FLOOR

Stacks 1 & 3				Stacks 2 & 4			
Plank #	Length	Plank #	Length	Plank #	Length	Plank #	Length
Top of Stack							
23	17' 7"			13	28' 6"	14	27' 10"
22	19' 3"	25	13' 3"	12	29" 2"	13	28' 6"
		24	15' 7"				
27	5' 9"			11	29' 9"	12	29' 2"
24	15' 7"	27	5' 9"	10	30' 2"	11	29' 9"
21	20' 9"	26	10' 3"				
		23	17' 7"	9	30' 7"	10	30' 2"
26	10' 3"			8	30' 11"	9	30' 7"
25	13' 3"	22	19' 3"				
20	22' 1"	21	20' 9"	7	31' 3"	8	30' 11"
				6	31' 6"	7	31' 3"
19	23' 4"	20	22' 1"	5	31' 9"	6	31' 6"
18	24' 5"	19	23' 4"	4	31' 11"	5	31' 9"
17	25' 5"	18	24' 5"	3	32'	4	31' 11"
16	26' 4"	17	25' 5"	2	32' 2"	3	32'
15	27' 1"	16	26' 4"	1	32' 2"	2	32' 2"
14	27' 10"	15	27' 1"	0	32' 2"	1	32' 2"
Bottom of Stack							

36' DIA. BIN SPLIT PLANK LAYOUT

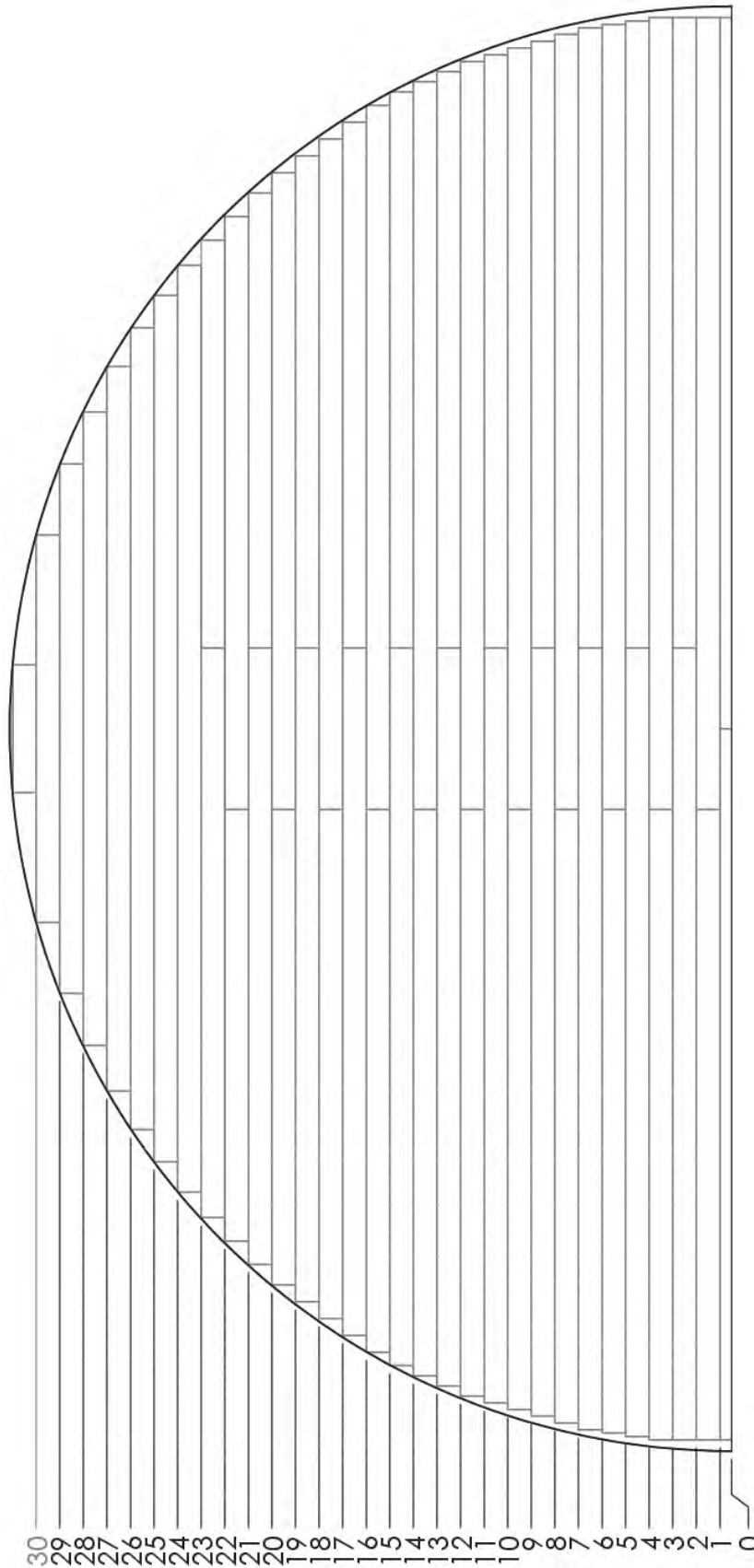

SWFS0023
06/24/2019 CLW

Layout & Location of Floor Planks

LOCATING SPLIT PLANKS FOR 36' DIA. BIN

A 36' split-plank floor is shipped in six stacks.

1. Label stacks as shown below by measuring top plank of each stack.
2. See layout on previous page. Plank closest to sidewall (Plank 30, measuring 3' 2") is starter plank. There is one in Stack 3 and one in Stack 6. It is shortest plank in each stack.
3. Lay out planks of Stacks 1-3. Install in descending order from Plank 30 to Plank 0. **NOTE:** Most planks are split, with sections A and B. Make sure to offset splices as shown on previous page. After reaching center of bin, install planks in ascending order on other side of bin.

See Page 33 for important notes.

36' FLOOR (SPLIT)

Stacks 1 & 4		Stacks 2 & 5		Stacks 3 & 6	
Plank #	Length	Plank #	Length	Plank #	Length
Top of Stack					
9A	18'10"	18A	16' 2"	28	13' 1"
9B	14'10"	18B	12' 2"	29	9' 7"
8A	19' 0"	17A	16' 7"	22A	14' 1"
8B	15' 0"	17B	12' 7"	22B	10' 1"
7A	19' 2"	16A	17' 0"	21A	14' 8"
7B	15' 2"	16B	13' 0"	21B	10' 8"
6A	19' 4"	15A	17' 5"	20A	15' 3"
6B	15' 4"	15B	13' 5"	20B	11' 3"
5A	19' 5"	14A	17' 9"	19A	15' 9"
5B	15' 5"	14B	13' 9"	19B	11' 9"
4A	19' 6"	13A	18' 0"	26	17'11"
4B	15' 6"	13B	14' 0"	27	15' 8"
3A	19' 7"	12A	18' 3"	24	21' 5"
3B	15' 7"	12B	14' 3"	25	19'10"
2A	19' 7"	11A	18' 6"	23	22'11"
2B	15' 7"	11B	14' 6"	0A	17' 7"
				30	3' 2"
1A	19' 7"	10A	18' 8"		
1B	15' 7"	10B	14' 8"		
Bottom of Stack					

LOCATING NON-SPLIT PLANKS FOR 36' DIA. BIN

A 36' non-split floor is shipped in four stacks.

1. Label stacks as shown below by measuring top plank of each stack.
2. See layout on Page 48, ignoring split lines. Plank closest to sidewall (Plank 30, measuring 6' 3") is starter plank. There is one in Stack 1 and one in Stack 3. It is shortest plank in each stack.
3. Lay out planks of Stacks 1 & 2. Install in descending order from Plank 30 to Plank 1, then work in ascending order on other side of bin.

See Page 33 for important notes.

36' FLOOR (NON-SPLIT)

Stacks 1 & 3	Stacks 2 & 4
Plank # Length	Plank # Length

<i>Top of Stack</i>			
26	18' 6"	14	31' 7"
25	20' 4"	13	32' 2"
24	21' 11"	12	32' 8"
23	23' 4"	11	33' 2"
30	6' 3"	10	33' 6"
27	16' 5"	9	33' 10"
22	24' 7"		
		8	34' 2"
29	10' 10"	7	34' 5"
28	14'		
21	25' 9"	6	34' 8"
		5	34' 10"
20	26' 10"		
19	27' 10"	4	35'
		3	35' 1"
18	28' 8"		
17	29' 6"	2	35' 2"
		1	35' 2"
16	30' 3"		
15	31'		
<i>Bottom of Stack</i>			

42' DIA. BIN SPLIT PLANK LAYOUT

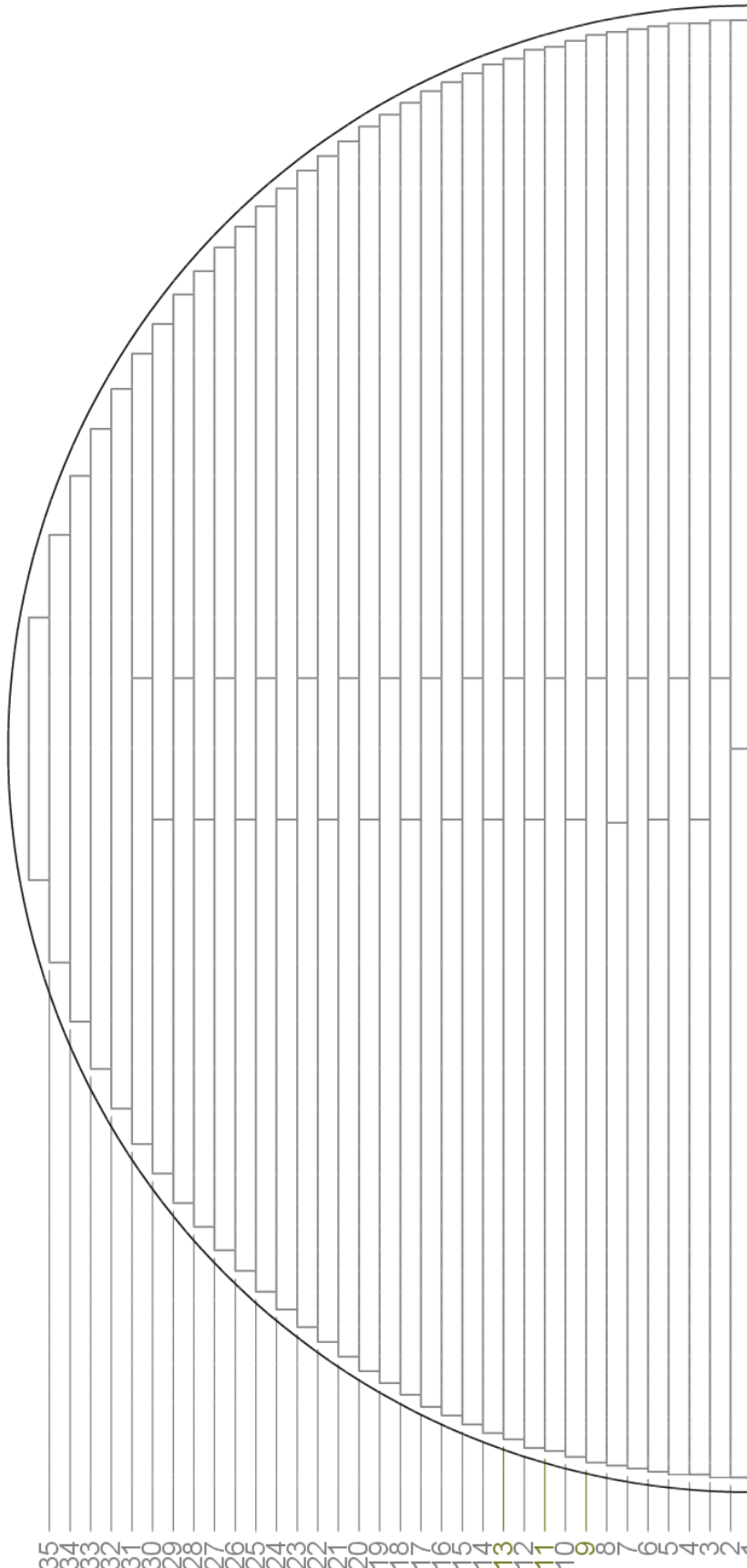

SWFS0008
06/24/18 CLW

SWFS0008 06/24/18 CLW

Layout & Location of Floor Planks

LOCATING SPLIT PLANKS FOR 42' DIA. BIN

A 42' split-plank floor is shipped in eight stacks.

1. Label stacks as shown below by measuring top plank of each stack.
2. See layout on previous page. Plank closest to sidewall (Plank 35, measuring 7' 5") is starter plank. There is one in Stack 2 and one in Stack 6. It is shortest plank in each stack.
3. Lay out planks of Stacks 1-4. Install in descending order from Plank 35 to Plank 1. **NOTE:** Most planks are split, with sections A and B. Make sure to offset splices as shown on previous page. After reaching center of bin, install planks in ascending order on other side of bin.

See Page 33 for important notes.

42' FLOOR (SPLIT)

Stacks 1 & 5 Plank # Length		Stacks 2 & 6 Plank # Length		Stacks 3 & 7 Plank # Length		Stacks 4 & 8 Plank # Length	
Top of Stack							
8A	22' 2"	22A	18' 4"	16A	20' 7"	30A	13' 2"
8B	18' 2"	22B	14' 4"	16B	16' 7"	30B	9' 2"
7A	22' 3"	21A	18' 9"	15A	20' 10"	29A	14' 0"
7B	18' 3"	21B	14' 9"	15B	16' 10"	29B	10' 0"
6A	22' 4"	20A	19' 2"	14A	21' 1"	28A	14' 10"
6B	18' 4"	20B	15' 2"	14B	17' 1"	28B	10' 10"
5A	22' 5"	19A	19' 7"	13A	21' 4"	27A	15' 6"
5B	18' 5"	19B	15' 7"	13B	17' 4"	27B	11' 6"
4A	22' 6"	18A	19' 11"	12A	21' 6"	26A	16' 2"
4B	18' 6"	18B	15' 11"	12B	17' 6"	26B	12' 2"
3A	22' 6"	17A	20' 3"	11A	21' 9"	25A	16' 9"
3B	18' 6"	17B	16' 3"	11B	17' 9"	25B	12' 9"
2A	22' 7"	33	15' 5"	10A	21' 10"	24A	17' 4"
2B	18' 7"	34	12' 1"	10B	17' 10"	24B	13' 4"
		35	7' 5"				
1A	20' 7"	31	20' 4"	9A	22' 0"	23A	17' 10"
1B	20' 7"	32	18' 1"	9B	18' 0"	23B	13' 10"
Bottom of Stack							

LOCATING NON-SPLIT PLANKS FOR 42' DIA. BIN

A 42' non-split floor is shipped in four stacks.

1. Label stacks as shown below by measuring top plank of each stack.
2. See layout on Page 51, ignoring split lines. Plank closest to sidewall (Plank 35, measuring 7' 5") is starter plank. There is one in Stack 2 and one in Stack 4. It is shortest plank in each stack.
3. Lay out planks in Stacks 1 & 2. Install in descending order from Plank 35 to Plank 1, then work in ascending order on other side of bin.

See Page 33 for important notes.

42' FLOOR (NON-SPLIT)

Stacks 1 & 3		Stacks 2 & 4	
Plank #	Length	Plank #	Length
Top of Stack			
17	36' 6"	32	18' 1"
18	35' 10"	33	15' 5"
15	37' 8"	31	20' 4"
16	37' 1"	34	12' 1"
		35	7' 5"
13	38' 7"	29	24' 0"
14	38' 2"	30	22' 3"
11	39' 5"	27	27' 0"
12	39' 0"	28	25' 7"
9	40' 0"	25	29' 6"
10	39' 8"	26	28' 4"
7	40' 6"	23	31' 8"
8	40' 3"	24	30' 7"
5	40' 10"	21	33' 6"
6	40' 8"	22	32' 7"
3	41' 0"	19	35' 1"
4	40' 11"	20	34' 4"
1	41' 1"		
2	41' 1"		
Bottom of Stack			

48' DIA. BIN SPLIT PLANK LAYOUT

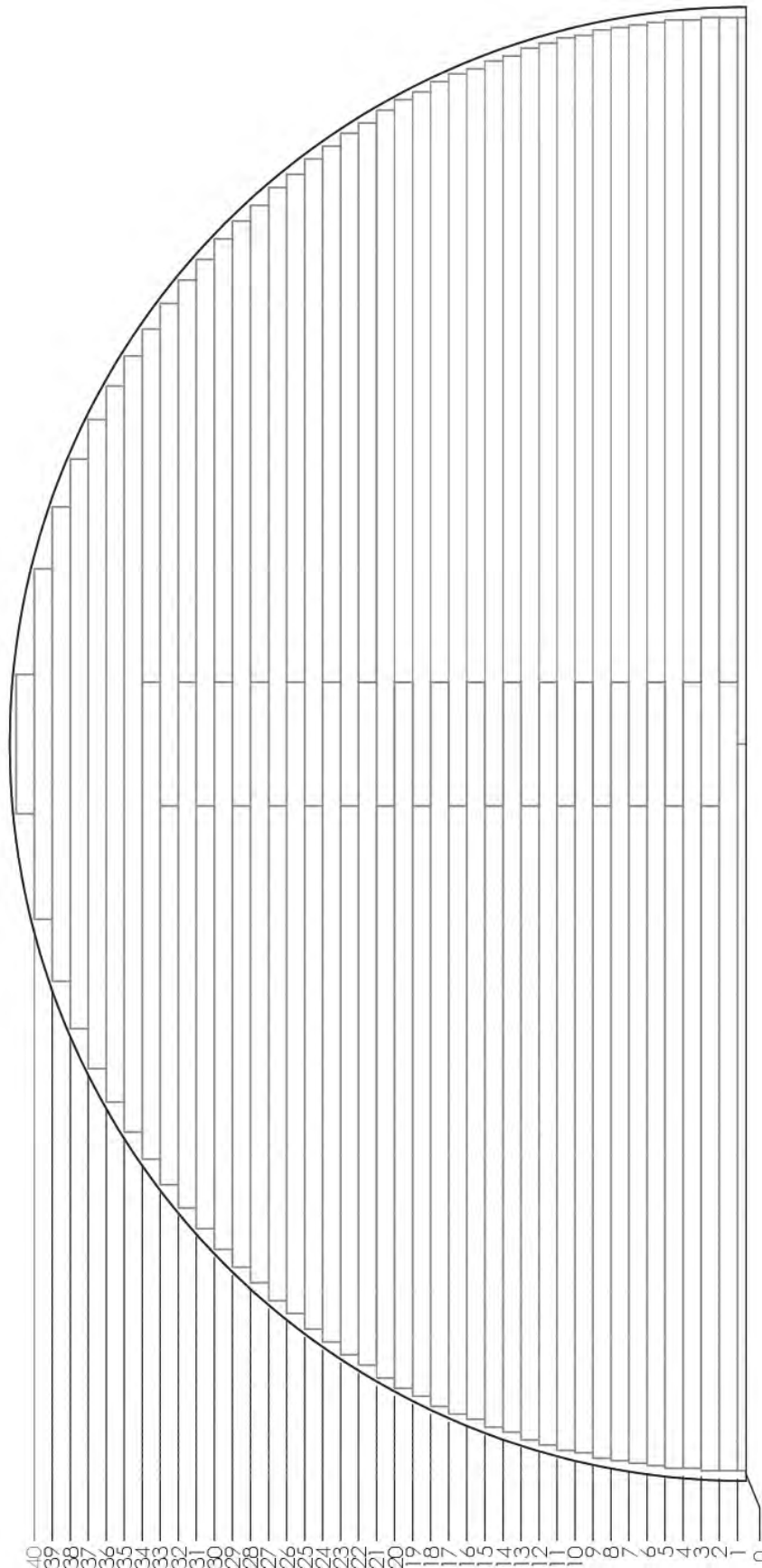

SWFS0009
06/24/2019 CLW

Layout & Location of Floor Planks

LOCATING SPLIT PLANKS FOR 48' DIA. BIN

A 48' split-plank floor is shipped in eight stacks.

1. Label stacks as shown below by measuring top plank of each stack.
2. See layout on previous page. Plank closest to sidewall (Plank 40, measuring 4' 6") is starter plank. There is one in Stack 4 and one in Stack 8. It is shortest plank in each stack.
3. Lay out planks of Stacks 1-4. Install in descending order from Plank 40 to Plank 0. **NOTE:** Most planks are split, with sections A and B. Make sure to offset splices as shown on previous page. After reaching center of bin, install planks in ascending order on other side of bin.

See Page 33 for important notes.

48' FLOOR (SPLIT)

Stacks 1 & 5 Plank # Length		Stacks 2 & 6 Plank # Length		Stacks 3 & 7 Plank # Length		Stacks 4 & 8 Plank # Length	
Top of Stack							
9A	24' 11"	18A	23' 1"	27A	19' 5"	38	15' 4"
9B	20' 11"	18B	19' 1"	27B	15' 5"	39	11' 4"
						40	4' 6"
8A	25' 1"	17A	23' 5"	26A	20' 0"	32B	16' 3"
8B	21' 1"	17B	19' 5"	26B	16' 0"	33B	15' 5"
7A	25' 2"	16A	23' 8"	25A	20' 5"	31A	17' 0"
7B	21' 2"	16B	19' 8"	25B	16' 5"	31B	13' 0"
6A	25' 3"	15A	23' 10"	24A	20' 11"	30A	17' 8"
6B	21' 3"	15B	19' 10"	24B	16' 11"	30B	13' 8"
5A	25' 4"	14A	24' 1"	23A	21' 4"	29A	18' 4"
5B	21' 4"	14B	20' 1"	23B	17' 4"	29B	14' 4"
4A	25' 5"	13A	24' 3"	22A	21' 9"	28A	18' 11"
4B	21' 5"	13B	20' 3"	22B	17' 9"	28B	14' 11"
3A	25' 5"	12A	24' 6"	21A	22' 1"	36	21' 0"
3B	21' 5"	12B	20' 6"	21B	18' 1"	37	18' 5"
2A	25' 6"	11A	24' 8"	20A	22' 6"	34	25' 1"
2B	21' 6"	11B	20' 8"	20B	18' 6"	35	23' 2"
1A	25' 6"	10A	24' 10"	19A	22' 10"	0	23' 6"
1B	21' 6"	10B	20' 10"	19B	18' 10"	32A	12' 3"
						33A	11' 5"
Bottom of Stack							

LOCATING NON-SPLIT PLANKS FOR 48' DIA. BIN

A 48' non-split floor is shipped in four stacks.

1. Label stacks as shown below by measuring top plank of each stack.
2. See layout on Page 54, ignoring split lines. Plank closest to sidewall (Plank 40, measuring 4' 4") is starter plank. There is one in Stack 3 and one in Stack 4. It is shortest plank in each stack.
3. Lay out planks in Stacks 1 & 3. Work in descending order from Plank 40 to Plank 0, then work in ascending order on other side of bin.

See Page 33 for important notes.

48' FLOOR (NON-SPLIT)							
Stack 1		Stack 2		Stack 3		Stack 4	
Plank #	Length	Plank #	Length	Plank #	Length	Plank #	Length
Top of Stack							
18	42' 3"	19	41' 8"	40	4' 4"	39	11' 2"
19	41' 8"	20	41' 0"	38	15' 2"	40	4' 4"
				39	11' 2"		
16	43' 5"	17	42' 10"			37	18' 3"
17	42' 10"	18	42' 3"			38	15' 2"
				36	20' 10"		
14	44' 3"	15	43'	37	18' 3"	35	23' 1"
15	43' 10"	16	43' 5"			36	20' 10"
				34	25' 1"		
12	45' 1"	13	44' 8"	35	23' 1"	33	26' 10"
13	44' 8"	14	44' 3"			34	25' 1"
				32	28' 6"		
10	45' 8"	11	45' 5"	33	26' 10"	31	30' 0"
11	45' 5"	12	45' 1"			32	28' 6"
				30	31' 4"		
8	46' 2"	9	46' 0"	31	30' 0"	29	32' 8"
9	46' 0"	10	45' 8"			30	31' 4"
				28	33' 10"		
6	46' 7"	7	46' 5"	29	32' 8"	27	34' 11"
7	46' 5"	8	46' 2"			28	33' 10"
				26	36' 0"		
4	46' 10"	5	46' 9"	27	34' 11"	25	36' 11"
5	46' 9"	6	46' 7"			26	36' 0"
				24	37' 10"		
2	47' 0"	3	46'	25	36' 11"	23	38' 9"
3	46' 11"	4	46'			24	37' 10"
				22	39' 6"		
0	47' 0"	1	47' 0"	23	38' 9"	21	40' 3"
1	47' 0"	2	47' 0"			22	39' 6"
				20	41' 0"		
				21	40' 3"		
Bottom of Stack							

54' DIA. BIN PLANK LAYOUT

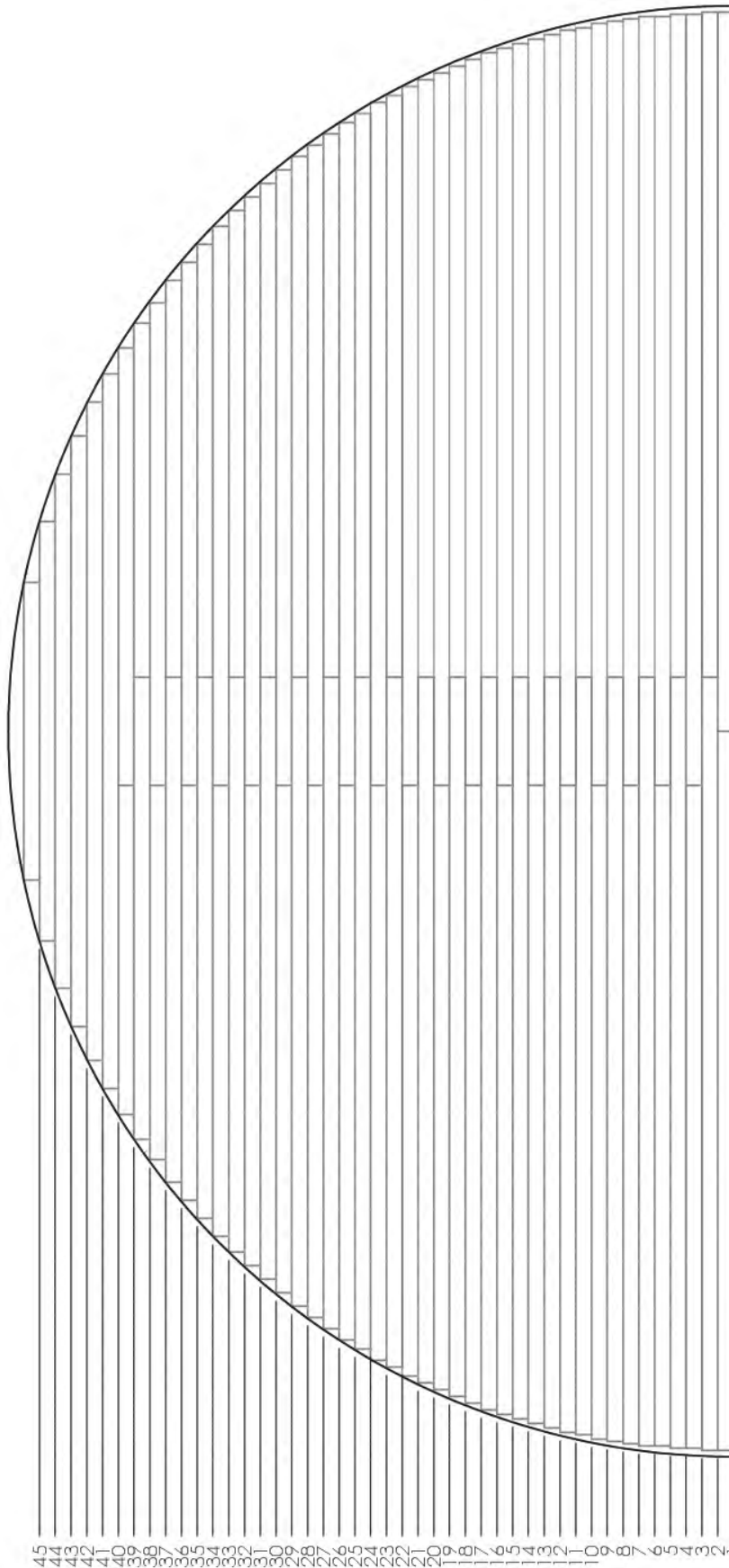

SWFS0010
06/24/2019 CLW

Layout & Location of Floor Planks

LOCATING PLANKS FOR 54' DIA. BIN

A 54' floor is shipped in eight stacks.

1. Label stacks as shown below by measuring top plank of each stack.
2. See layout on previous page. Plank closest to sidewall (Plank 45, measuring 11' 0") is starter plank. There is one in Stack 4 and one in Stack 8. It is shortest plank in each stack.
3. Lay out planks of Stacks 1-4. Install in descending order from Plank 45 to Plank 1. **NOTE:** Most planks are split, with sections A and B. Make sure to offset splices as shown on previous page. After reaching center of bin, install planks in ascending order on other side of bin.

See Page 33 for important notes.

54' FLOOR

Stacks 1 & 5		Stacks 2 & 6		Stacks 3 & 7		Stacks 4 & 8	
Plank #	Length	Plank #	Length	Plank #	Length	Plank #	Length
Top of Stack							
11A	27' 11"	22A	25' 6"	32A	21' 3"	44	15' 6"
11B	23' 11"	22B	21' 6"	32B	17' 3"	45	11' 0"
10A	28' 0"	21A	25' 10"	31A	21' 9"	39A	16' 2"
10B	24' 0"	21B	21' 10"	31B	17' 9"	39B	12' 2"
9A	28' 2"	20A	26' 1"	30A	22' 3"	38A	17' 1"
9B	24' 2"	20B	22' 1"	30B	18' 3"	38B	13' 1"
8A	28' 3"	19A	26' 4"	29A	22' 9"	37A	17' 10"
8B	24' 3"	19B	22' 4"	29B	18' 9"	37B	13' 10"
7A	28' 4"	18A	26' 7"	28A	23' 3"	36A	18' 8"
7B	24' 4"	18B	22' 7"	28B	19' 3"	36B	14' 8"
6A	28' 5"	17A	26' 10"	27A	23' 8"	35A	19' 4"
6B	24' 5"	17B	22' 10"	27B	19' 8"	35B	15' 4"
5A	28' 5"	16A	27' 1"	26A	24' 1"	34A	20' 0"
5B	24' 5"	16B	23' 1"	26B	20' 1"	34B	16' 0"
4A	28' 6"	15A	27' 3"	25A	24' 6"	33A	20' 8"
4B	24' 6"	15B	23' 3"	25B	20' 6"	33B	16' 8"
3A	28' 6"	14A	27' 5"	24A	24' 10"	42	21' 10"
3B	24' 6"	14B	23' 5"	24B	20' 10"	43	19' 0"
2A	28' 7"	13A	27' 7"	23A	25' 3"	40	26' 5"
2B	24' 7"	13B	23' 7"	23B	21' 3"	41	24' 4"
1A	26' 7"	12A	27' 9"				
1B	26' 7"	12B	23' 9"				
Bottom of Stack							

60' DIA. BIN PLANK LAYOUT

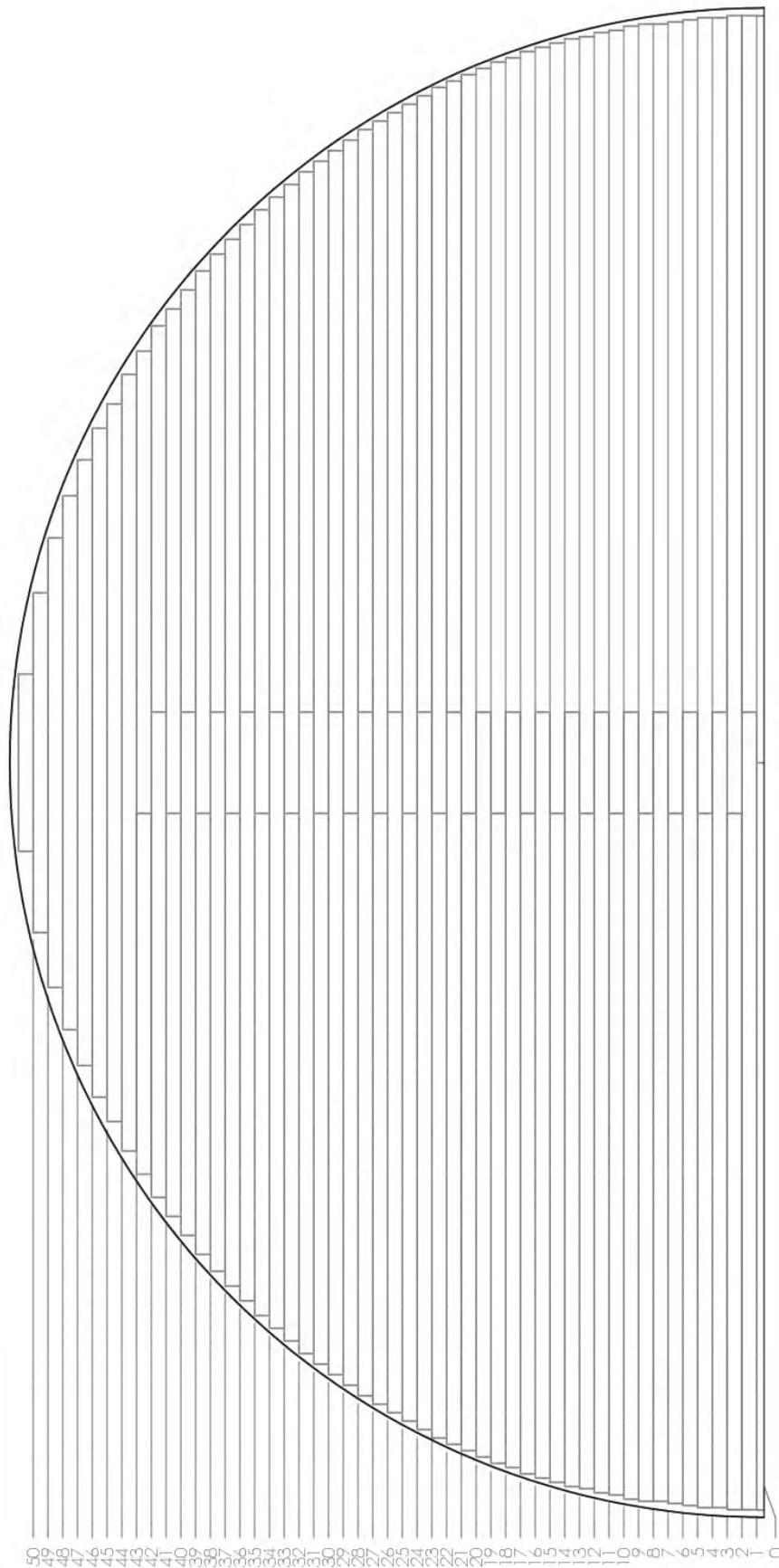

SWFS0016
06/24/2019 CLW

Layout & Location of Floor Planks

LOCATING PLANKS FOR 60' DIA. BIN

A 60' floor is shipped in 10 stacks.

1. Label stacks as shown below by measuring top plank of each stack.
2. See layout on previous page. Plank closest to sidewall (Plank 50, measuring 7' 0") is starter plank. There are two in Stack 6. They are shortest planks in stack.
3. Lay out planks of Stacks 1-6. Install in descending order from Plank 50 to Plank 0. **NOTE:** Most planks are split, with sections A and B. Make sure to offset splices as shown on previous page. After reaching center of bin, install planks in ascending order on other side of bin.

See Page 33 for important notes.

60' FLOOR

Stacks 1 & 7		Stacks 2 & 8		Stacks 3 & 9		Stacks 4 & 10		Stack No. 5		Stack No. 6	
Plank #	Length	Plank #	Length	Plank #	Length	Plank #	Length	Plank #	Length	Plank #	Length
Top of Stack											
10A	30' 11"	20A	29' 2"	30A	25' 9"	40A	19' 11"	42B	14' 3"	41B	15' 3"
10B	26' 11"	20B	25' 2"	30B	21' 9"	40B	15' 11"	42B	14' 3"	41B	15' 3"
9A	31' 1"	19A	29' 5"	29A	26' 2"	39A	20' 8"	42A	18' 3"	48	17' 9"
9B	27' 1"	19B	25' 5"	29B	22' 2"	39B	16' 8"	42A	18' 3"	48	17' 9"
8A	31' 2"	18A	29' 8"	28A	26' 7"	38A	21' 5"	41A	19' 2"	47	21' 1"
8B	27' 2"	18B	25' 8"	28B	22' 7"	38B	17' 5"	41A	19' 2"	49	13' 5"
										50	7' 0"
7A	31' 2"	17A	29' 10"	27A	27' 0"	37A	22' 1"	47	21' 1"		
7B	27' 2"	17B	25' 10"	27B	23' 0"	37B	18' 1"	49	13' 5"	46	23' 11"
								50	7' 0"	46	23' 11"
6A	31' 3"	16A	30' 1"	26A	27' 4"	36A	22' 8"				
6B	27' 3"	16B	26' 1"	26B	23' 4"	36B	18' 8"	44	28' 4"	45	26' 5"
								44	28' 4"	45	26' 5"
5A	31' 4"	15A	30' 3"	25A	27' 8"	35A	23' 3"				
5B	27' 4"	15B	26' 3"	25B	23' 8"	35B	19' 3"	0A	29' 6"	43	30' 8"
								0B	29' 6"	43	30' 8"
4A	31' 5"	14A	30' 5"	24A	28' 0"	34A	23' 10"				
4B	27' 5"	14B	26' 5"	24B	24' 0"	34B	19' 10"				
3A	31' 5"	13A	30' 7"	23A	28' 4"	33A	24' 4"				
3B	27' 5"	13B	26' 7"	23B	24' 4"	33B	20' 4"				
2A	31' 6"	12A	30' 8"	22A	28' 8"	32A	24' 10"				
2B	27' 6"	12B	26' 8"	22B	24' 8"	32B	20' 10"				
1A	31' 6"	11A	30' 10"	21A	28' 11"	31A	25' 4"				
1B	27' 6"	11B	26' 10"	21B	24' 11"	31B	21' 4"				
Bottom of Stack											

72' DIA. BIN PLANK LAYOUT

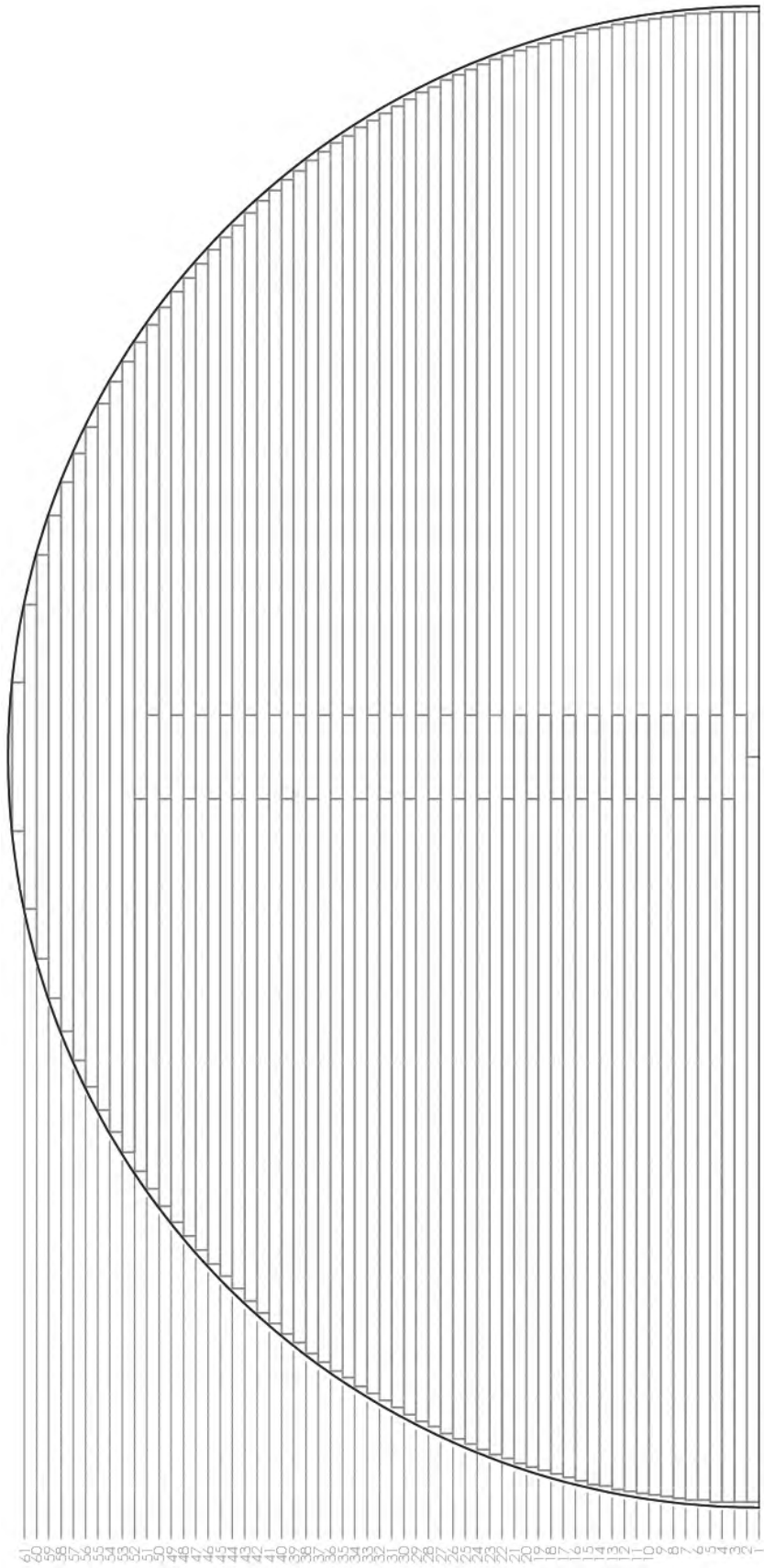

SWFS0018
06/25/2019 CLW

Layout & Location of Floor Planks

LOCATING PLANKS FOR 72' DIA. BIN

A 72' floor is shipped in 14 stacks.

1. Label stacks as shown below and on next page by measuring top plank of each stack.
2. See layout on previous page. Plank closest to sidewall (Plank 61, measuring 7' 1") is starter plank. There is one in Stack 7 and one in Stack 14. It is shortest plank in each stack.
3. Lay out planks of Stacks 1-7. Work in descending order from Plank 61 to Plank 1. **NOTE:** Most planks are split, with sections A and B. Make sure to offset splices as shown on previous page. After reaching center of bin, install planks in ascending order on other side of bin.

See Page 33 for important notes.

72' FLOOR

Stacks 1 & 8		Stacks 2 & 9		Stacks 3 & 10		Stacks 4 & 11	
Plank #	Length	Plank #	Length	Plank #	Length	Plank #	Length
Top of Stack							
1B	35'6"	16B	32'4"	24B	30'9"	32B	28'4"
1A	35'6"	16A	36'4"	24A	34'9"	32A	32'4"
8B	33'3"	15B	32'6"	23B	31'0"	31B	28'8"
8A	37'3"	15A	36'6"	23A	35'0"	31A	32'8"
7B	33'4"	14B	32'8"	22B	31'3"	30B	29'0"
7A	37'4"	14A	36'8"	22A	35'3"	30A	33'0"
6B	33'5"	13B	32'9"	21B	31'5"	29B	29'4"
6A	37'5"	13A	36'9"	21A	35'5"	29A	33'4"
5B	33'5"	12B	32'11"	20B	31'8"	28B	29'8"
5A	37'5"	12A	36'11"	20A	35'8"	28A	33'8"
4B	33'6"	11B	33'0"	19B	31'10"	27B	29'11"
4A	37'6"	11A	37'0"	19A	35'10"	27A	33'11"
3B	33'6"	10B	33'1"	18B	32'0"	26B	30'3"
3A	37'6"	10A	37'1"	18A	36'0"	26A	34'3"
2B	33'6"	9B	33'2"	17B	32'2"	25B	30'6"
2A	37'6"	9A	37'2"	17A	36'2"	25A	34'6"
Bottom of Stack							

See next page for Stacks 5-7 & 12-14

Layout & Location of Floor Planks

72' FLOOR

Stacks 5 & 12		Stacks 6 & 13		Stacks 7 & 14	
Plank #	Length	Plank #	Length	Plank #	Length
Top of Stack					
57	26'2"	45B	22'2"	61	7'1"
56	28'11"	45A	26'2"	60	14'6"
37B	26'5"	44B	22'9"	51B	17'9"
37A	30'5"	44A	26'9"	51A	21'9"
36B	26'10"	43B	23'4"	50B	18'7"
36A	30'10"	43A	27'4"	50A	22'7"
35B	27'3"	42B	23'11"	59	19'3"
35A	31'3"	42A	27'11"	58	23'0"
34B	27'7"	41B	24'6"	49B	19'5"
34A	31'7"	41A	28'6"	49A	23'5"
33B	28'0"	40B	25'0"	48B	20'2"
33A	32'0"	40A	29'0"	48A	24'2"
55	31'5"	39B	25'6"	47B	20'10"
54	33'8"	39A	29'6"	47A	24'10"
53	35'9"	38B	25'11"	46B	21'6"
52	37'8"	38A	29'11"	46A	25'6"
Bottom of Stack					

75' DIA. BIN PLANK LAYOUT

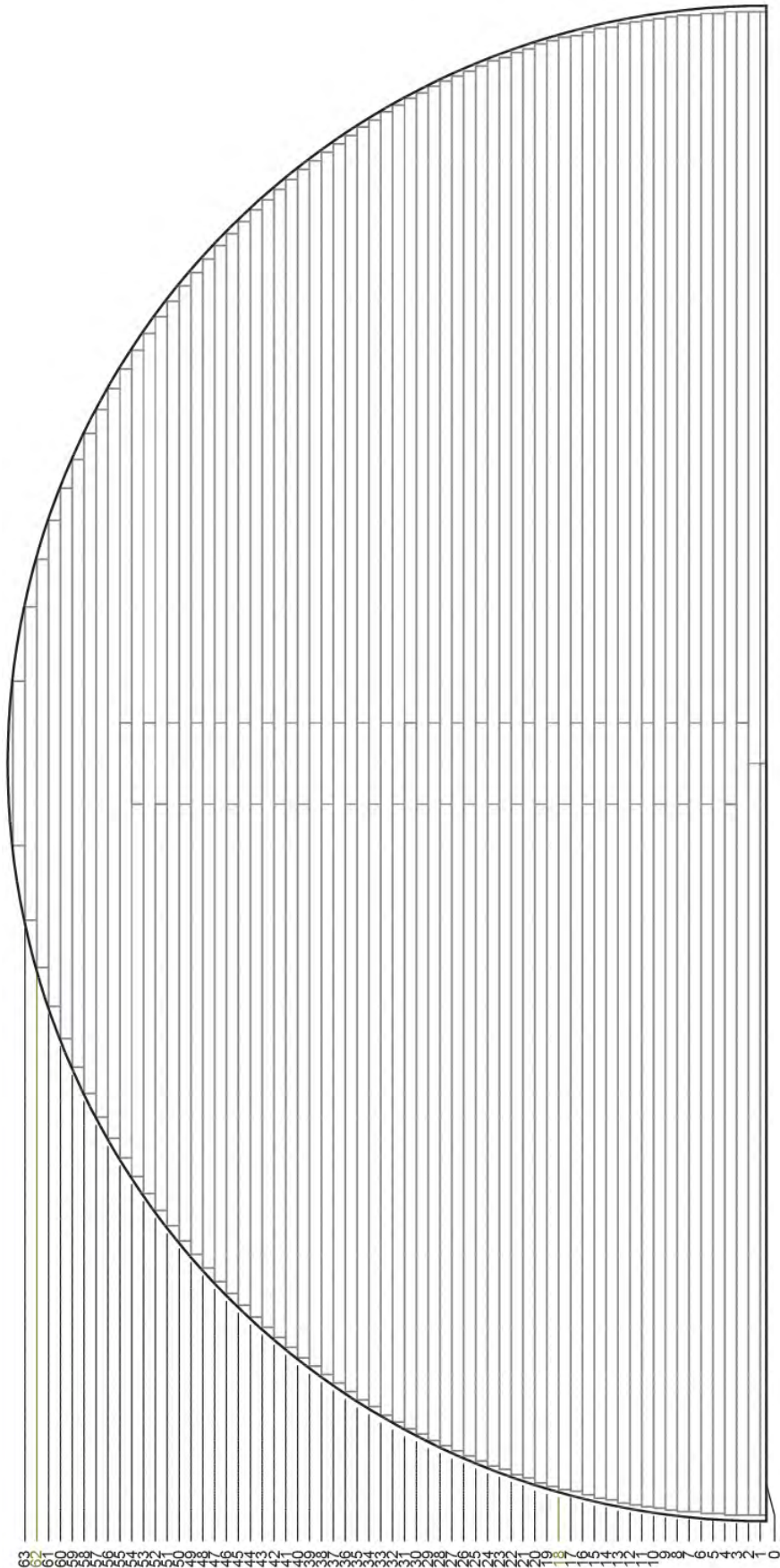

SWFS0019
06/25/2019 CLW

Layout & Location of Floor Planks

LOCATING PLANKS FOR 75' DIA. BIN

A 75' floor is shipped in 12 stacks.

1. Label stacks as shown below by measuring top plank of each stack.
2. See layout on previous page. Plank closest to sidewall (Plank 63, measuring 8' 1") is starter plank. There is one in Stack 6 and one in Stack 12. It is shortest plank in each stack.
3. Lay out planks of Stacks 1-6. Work in descending order from Plank 63 to Plank 0. **NOTE:** Most planks are split, with sections A and B. Make sure to offset splices as shown on previous page. After reaching center of bin, install planks in ascending order on other side of bin.

See Page 33 for important notes.

75' FLOOR

Stacks 1 & 7		Stacks 2 & 8		Stacks 3 & 9		Stacks 4 & 10		Stacks 5 & 11		Stacks 6 & 12	
Plank #	Length	Plank #	Length	Plank #	Length	Plank #	Length	Plank #	Length	Plank #	Length
Top of Stack											
10A	34' 7"	20A	33' 2"	30A	30' 9"	40A	26' 9"	50A	20' 9"	62	15' 5"
10B	38' 7"	20B	37' 2"	30B	34' 9"	40B	30' 9"	50B	24' 9"	63	8' 1"
9A	34' 8"	19A	33' 5"	29A	31' 0"	39A	27' 3"	49A	21' 6"	54A	17' 5"
9B	38' 8"	19B	37' 5"	29B	35' 0"	39B	31' 3"	49B	25' 6"	54B	21' 5"
8A	34' 9"	18A	33' 7"	28A	31' 4"	38A	27' 8"	48A	22' 2"	53A	18' 4"
8B	38' 9"	18B	37' 7"	28B	35' 4"	38B	31' 8"	48B	26' 2"	53B	22' 4"
7A	34' 10"	17A	33' 9"	27A	31' 7"	37A	28' 1"	47A	22' 10"	52A	19' 2"
7B	38' 10"	17B	37' 9"	27B	35' 7"	37B	32' 1"	47B	26' 10"	52B	23' 2"
6A	34' 10"	16A	33' 10"	26A	31' 10"	36A	28' 6"	46A	23' 6"	51A	20' 0"
6B	38' 10"	16B	37' 10"	26B	35' 10"	36B	32' 6"	46B	27' 6"	51B	24' 0"
5A	34' 11"	15A	34' 0"	25A	32' 1"	35A	28' 11"	45A	24' 1"	60	23' 11"
5B	38' 11"	15B	38' 0"	25B	36' 1"	35B	32' 11"	45B	28' 1"	61	20' 1"
4A	34' 11"	14A	34' 2"	24A	32' 4"	34A	29' 4"	44A	24' 8"	58	29' 11"
4B	38' 11"	14B	38' 2"	24B	36' 4"	34B	33' 4"	44B	28' 8"	59	27' 1"
3A	35' 0"	13A	34' 3"	23A	32' 7"	33A	29' 8"	43A	25' 3"	56	34' 10"
3B	39' 0"	13B	38' 3"	23B	36' 7"	33B	33' 8"	43B	29' 3"	57	32' 6"
2A	35' 0"	12A	34' 5"	22A	32' 9"	32A	30' 1"	42A	25' 9"	55	36' 11"
2B	39' 0"	12B	38' 5"	22B	36' 9"	32B	34' 1"	42B	29' 9"	0A	37' 0"
1A	37' 0"	11A	34' 6"	21A	33' 0"	31A	30' 5"	41A	26' 3"		
1B	37' 0"	11B	38' 6"	21B	37' 0"	31B	34' 5"	41B	30' 3"		
Bottom of Stack											

78' DIA. BIN PLANK LAYOUT

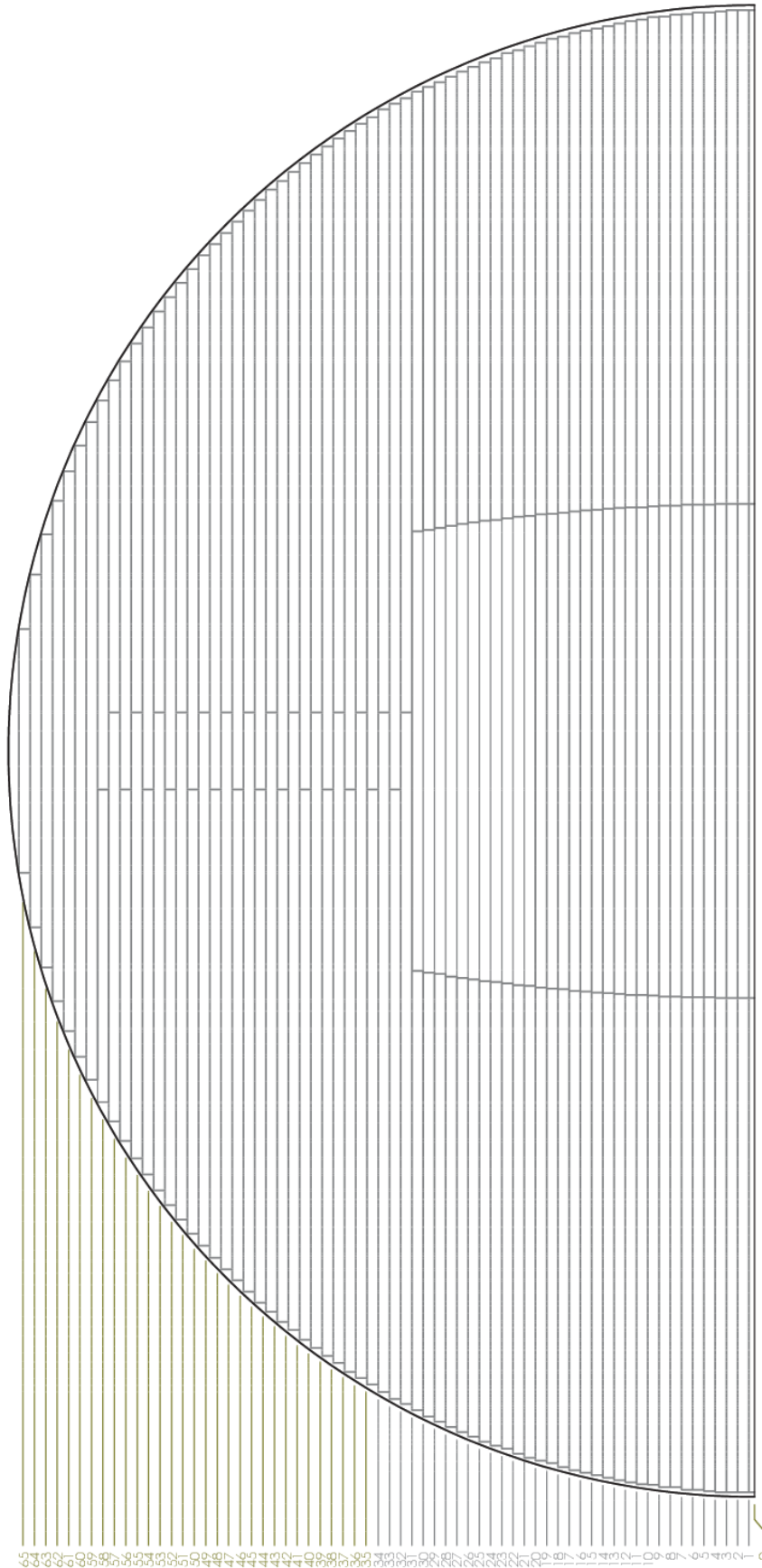

SWFS0020
06/25/2019 CLW

Layout & Location of Floor Planks

LOCATING PLANKS FOR 78' DIA. BIN

A 78' floor is shipped in 17 stacks.

1. Label stacks as shown below and on next page by measuring top planks of each stack.
2. See layout on previous page. Plank closest to sidewall (Plank 65, measuring 12' 8") is starter plank. There are two in Stack 10. They are shortest planks in stack.
3. Lay out planks of Stacks 1-10. Work in descending order from Plank 65 to Plank 0. **NOTE:** Most planks are split, with sections A, B and, in some cases, C. Make sure to offset splices as shown on previous page. After reaching center of bin, install planks in ascending order on other side of bin.

See Page 33 for important notes.

Stack 1		Stacks 2 & 11		Stacks 3 & 12		Stacks 4 & 13		Stacks 5 & 14	
Plank #	Length	Plank #	Length	Plank #	Length	Plank #	Length	Plank #	Length
Top of Stack									
6A	25'7"	12A	25'3"	18A	24'8"	24A	23'11"	56A	22'3"
5A	25'7"	11C	25'3"	17C	24'9"	23C	24'0"	29C	23'0"
5B	25'7"	11B	25'4"	17B	24'9"	23B	24'0"	29B	23'0"
4C	25'7"	11A	25'4"	17A	24'10"	23A	24'1"	29A	23'1"
4B	25'7"	10C	25'4"	16C	24'10"	22C	24'2"	28C	23'2"
4A	25'8"	10B	25'4"	16B	24'11"	22B	24'2"	28B	23'2"
3C	25'7"	10A	25'5"	16A	24'11"	22A	24'2"	28A	23'3"
3B	25'8"	9C	25'5"	15C	24'11"	21C	24'3"	27C	23'4"
3A	25'8"	9B	25'5"	15B	25'0"	21B	24'4"	27B	23'5"
2C	25'8"	8C	25'5"	15A	25'0"	21A	24'4"	27A	23'5"
2B	25'8"	8B	25'6"	14C	25'0"	20C	24'5"	26C	23'6"
2A	25'8"	7C	25'6"	14B	25'1"	20B	24'5"	26B	23'7"
1C	25'8"	8A	25'6"	14A	25'1"	20A	24'6"	26A	23'7"
1B	25'8"	7A	25'6"	13C	25'1"	19C	24'6"	25C	23'8"
1A	25'8"	7B	25'6"	13B	25'2"	19B	24'7"	25B	23'9"
0C	25'8"	6C	25'6"	13A	25'2"	19A	24'7"	25A	23'9"
0B	25'8"	6B	25'7"	12C	25'2"	18C	24'8"	24C	23'10"
0A	25'8"	5C	25'7"	12B	25'3"	18B	24'8"	24B	23'11"
Bottom of Stack									

See next page for Stacks 6-10 & 15-17

Layout & Location of Floor Planks

LOCATING PLANKS FOR 78' DIA. BIN

78' FLOOR

Stacks 6 & 15		Stacks 7 & 16		Stacks 8 & 17		Stack 9		Stack 10	
Plank #	Length	Plank #	Length	Plank #	Length	Plank #	Length	Plank #	Length
Top of Stack									
33B	31'4"	45B	26'1"	30C	22'10"	56B	18'3"	6A	25'7"
32B	31'8"	44B	26'8"	30B	22'10"	56B	18'3"	5A	25'7"
42A	31'8"	43B	27'2"	30A	22'10"	64	18'4"	5B	25'7"
60	31'9"	42B	27'8"	51B	22'4"	64	18'4"	4C	25'7"
31B	31'11"	41B	28'1"	50B	23'1"	55B	19'2"	9A	25'5"
41A	32'1"	40B	28'7"	55A	23'2"	55B	19'2"	9A	25'5"
40A	32'6"	47A	28'11"	49B	23'9"	54B	20'0"	4B	25'7"
39A	33'0"	39B	29'0"	54A	24'0"	54B	20'0"	4A	25'8"
58B	16'3"	61	29'1"	48B	24'4"	58A	20'2"	3C	25'7"
57B	17'3"	46A	29'6"	53A	24'10"	58A	20'2"	3B	25'8"
38A	33'5"	38B	29'5"	47B	24'11"	53B	20'10"	3A	25'8"
37A	33'9"	37B	29'10"	46B	25'6"	53B	20'10"	2C	25'8"
59	34'2"	45A	30'1"	52A	25'7"	57A	21'3"	2B	25'8"
36A	34'3"	36B	30'3"	62	26'0"	57A	21'3"	2A	25'8"
35A	34'7"	35B	30'7"	51A	26'4"	52B	21'7"	1C	25'8"
34A	34'11"	44A	30'8"	50A	27'1"	52B	21'7"	1B	25'8"
33A	35'3"	34B	30'11"	49A	27'8"	63	22'6"	65	12'8"
32A	35'8"	43A	31'2"	48A	28'4"	63	22'6"	65	12'8"
31A	35'11"							1A	25'8"
Bottom of Stack									

See Page 33 for important notes.

NOTES



CONTACT INFORMATION

Sukup Dealer Information

Dealer name:	_____
Address:	_____
Cell phone:	_____
Office phone:	_____
Fax:	_____

In Case of Emergency

Have emergency numbers and written directions to your location near a phone.
Arrange and practice a safety plan.

Ambulance • Fire • Police: 9-1-1	
Bin rescue team:	_____
Local EMS team:	_____
911 Address of work site:	_____
Directions to work site:	_____

PRODUCT WARRANTY
REGISTRATION

Please scan QR code
to register online.



Sukup Manufacturing Co.

1555 255th Street, Box 677

Sheffield, Iowa, USA 50475-0677

Phone: 641-892-4222

Fax: 641-892-4629

Website: www.sukup.com

E-mail: info@sukup.com