



FASTIR™

Owner's Instruction & Parts Manual for Sukup Fastir and Fastir Plus Stirring Machines

Sukup Manufacturing Co.

1555 255th Street, Box 677

Sheffield, Iowa, USA 50475-0677

Phone: 641-892-4222

Fax: 641-892-4629

Website: www.sukup.com

E-mail: info@sukup.com

<u>DATE</u>	<u>REVISION</u>	<u>PAGE</u>
02/09/2026	– Updated warranty -----	4
	Added note on carriage motors & added wiring diagrams for Baldor motors-----	48, 54-59
	Added notes on carriage motor part numbers -----	67, 71 & 75
	Added warranty registration link -----	76
05/29/2025	– Updated instructions for track splice installation-----	11
	Added maintenance instruction for greasing down auger bearings-----	31
	Added guidance on fan use when storing very warm or wet grain when outside air is humid --	45
	Added note on reversing gearmotor rotation -----	48
	Corrected part number of long coupler -----	62
	Updated drawing & parts list for pivoting hanger -----	63
	Updated description of Ref. # 11 -----	71

Table of Contents

Limited Warranty	4
I. General Safety Practices	5
II. Placement of Fastir Safety Decals	7
Materials Required	8
Maximum Amps & Circuit Breaker Sizes	9
Assembly & Installation	10
I. Installing Track.....	10
II. Assembling & Installing Carriages.....	12
III. Installing Stabilizer Arm Kit.....	18
IV. Installing Tilt Switches	20
V. Installing Motors	20
VI. Installing Reversing Plates	21
VII. Installing Center Hanger & Related Parts	21
VIII. Installing & Adjusting Reversing Mechanism	23
IX. Wiring Gearmotor on Center Hanger	24
X. Wiring Motors.....	25
XI. Wiring Tilt Switches on Motors	25
XII. Installing Machine	27
XIII. Installing Rotating Contact.....	27
XIV. Installing Optional Spreader-Bar Kit	28
XV. Preparing Down Augers	28
XVI. Installing Down Augers.....	29
XVII. Final Steps.....	30
Fastir Operation Guidelines.....	31
I. Operation Procedures	31
II. Restarting Fastir Machine.....	31
III. Fastir Maintenance	31
IV. Gearmotor Lubrication.....	32
Fastir Troubleshooting Guide	32
I. Checking Reversing Mechanism	32
Principles of Grain Drying.....	34
I. Basic Principles	34
II. Drying Guidelines to Prevent Bin Wall Spoilage	38
III. Drying Precautions	38
Managing Stored Grain	40
I. Basic Principles	40
II. Grain Storage	41
III. Aeration	44
IV. Addressing Grain Storage Problems	45
V. Bin System Upkeep	46
Appendix A - Wiring Diagrams	48
Parts/Assemblies.....	60



**Steve Sukup, the late Eugene Sukup, Charles Sukup
Sukup Manufacturing Co., Sheffield, IA, USA**

Thank you for turning to Sukup Manufacturing Co. for your grain drying needs. In 1962, a young, innovative farmer named Eugene Sukup bought his first grain bin to dry and store shelled corn. However, he soon encountered problems with the process, such as crusting and hot spots. In response, Eugene developed and patented an idea for an automatic stirring machine—the idea from which Sukup Manufacturing Co. was born.

Sukup stirring machines have come a long way since they revolutionized in-bin drying, but they remain the simplest, most dependable stirring machines on the market. The Fastir stirring machine's adaptable design and variety of extras make it ideal for in-bin drying.

Fastir stirring machines eliminate overdried grain, increase airflow, and preserve grain quality.

Overdried grain resulting from typical heating processes has been a frequent problem when drying grain in bins, resulting in lower quality grain, wasted fuel and wasted time.

Sukup's goal has been to eliminate this problem by bringing the advantages of stirring to both low- and high-temperature in-bin drying systems. As the machine mixes and loosens bottom layers of grain that are easily overdried, grain may be heated to higher temperatures to achieve faster drying rates without any of the typical effects of overdrying.

The Fastir provides a low-cost solution for in-bin drying of grain. If additional stirring capacity is desired after installation, more down augers may be economically added to machines. In short, our stirring machine is an excellent tool for adding greater flexibility to any bin drying or storage system, whether at high or low temperature.

We hope that you return to Sukup for all of your grain storage, drying and handling needs. Along with the simply dependable Fastir, Sukup is the leader in unloading equipment, fans and heaters. Sukup also offers grain bins, stand-alone dryers and material handling equipment. From heaters to grain bins and everything in between, our family-owned company is dedicated to providing customers with the best quality products and the best value for their money.

This manual contains instructions for the installation, operation, and service of **Sukup Fastir** and **Fastir Plus** units. Fastir Plus has the same features as the Fastir, plus a stationary outside carriage. Carefully read and follow all instructions.

This document also contains a Parts/Assemblies section for use in identifying parts. See Page 60.



Sukup Manufacturing Co.

PO Box 677 Sheffield, IA USA 50475

Phone: 641-892-4222 Fax: 641-892-4629

E-mail: Info@sukup.com Visit us at: www.sukup.com

GRAIN HANDLING & MATERIAL HANDLING LIMITED WARRANTY

SUKUP MANUFACTURING CO. (Sukup) warrants to original retail purchaser that within time limits set forth, new equipment shall be free from defects in material and workmanship. A part will not be considered defective if it substantially fulfills performance specifications, including, but not limited to, parts with cosmetic (appearance) issues that will not affect life of product. Should any part prove defective within warranty period, part will be replaced or repaired without charge F.O.B. Sukup Manufacturing Co., Sheffield, Iowa USA or Distribution Centers - Arcola, Illinois; York, Nebraska; Cameron, Missouri; Defiance, Ohio; Jonesboro, Arkansas; Watertown, South Dakota. To claim warranty, a copy of original invoice is required.

THE FOREGOING LIMITED WARRANTY IS EXCLUSIVE AND IN LIEU OF ALL OTHER WARRANTIES OF MERCHANTABILITY, FITNESS FOR PARTICULAR PURPOSE AND OF ANY OTHER TYPE, WHETHER EXPRESS OR IMPLIED. Sukup neither assumes nor authorizes anyone to assume for it any other obligation or liability in connection with said part, and will not be liable for incidental or consequential damages. **THE REMEDIES STATED HEREIN SHALL BE THE EXCLUSIVE REMEDIES AVAILABLE UNDER THIS LIMITED WARRANTY.**

Sukup reserves the right to change specifications, add improvements or discontinue manufacture of any of its equipment without notice or obligation to purchasers of its equipment. This warranty gives you specific legal rights. You may also have other rights which vary according to state or province.

WARRANTY EXCLUSIONS - Labor, transportation, or any cost related to a service call is not provided by Sukup. This Limited Warranty does not apply to damage resulting from misuse, neglect, normal wear, or natural events, including, but not limited to, damage caused by animals, accident, or improper installation or maintenance. **ITEMS NOT MANUFACTURED BY SUKUP** (e.g. tires, belts, motors) **ARE COVERED UNDER WARRANTIES OF THEIR RESPECTIVE MANUFACTURERS AND ARE EXCLUDED FROM COVERAGE UNDER THE SUKUP WARRANTY.** Since the stirring down augers are so critical to the successful operation of the stirring machine, Sukup Manufacturing Co. will not warranty any machines unless they are equipped with Sukup down augers. **SUKUP MANUFACTURING CO. MAKES NO WARRANTY, EXPRESS OR IMPLIED, WITH RESPECT TO DOWN AUGERS LONGER THAN 20', INCLUDING, WITHOUT LIMITATION, ANY WARRANTY OF MERCHANTABILITY AND WARRANTY OF FITNESS FOR A PARTICULAR PURPOSE.**

Upon taking delivery of product, purchaser (dealer and/or end user) assumes responsibility for proper storage of all materials. Proper storage includes dry, temperature and humidity-controlled facilities, which eliminate the potential of moisture, including condensation, from causing white rust and/or corrosion of any sort. Warranty does not extend to defects, damage or cosmetic (appearance) issues caused by improper storage, handling or erection.

BASIC WARRANTY - All Sukup manufactured products are warranted for one year from date of purchase. Part(s) must be returned to Sukup within 30 days in event of failure.

EXTENDED STIRRING MACHINE WARRANTY - Sukup warrants stirring machines for two years from date of purchase.

EXTENDED STIRRING AUGER WARRANTY - Sukup warrants stirring down augers for two years from date of purchase. Must return top 18" of down auger to obtain credit.

EXTENDED FAN WARRANTY - Sukup warrants fans for two years from date of purchase.

EXTENDED HEATER CIRCUIT BOARD WARRANTY - Sukup warrants heater circuit boards for three years from date of purchase. Rebuilt circuit boards are warranted for one year from date of purchase.

EXTENDED MATERIAL HANDLING WARRANTY - Sukup warrants Material Handling equipment, excluding structural support systems, for two years from date of purchase.

REPLACEMENT PARTS WARRANTY PERIOD - Sukup warrants replacement parts (e.g. belts, sensors, rotating contacts, gearmotors, switches) purchased from Sukup for one (1) full drying season following purchase.

ELECTRIC MOTOR WARRANTY - Manufacturers of electric motors warranty them for at least 1 year from installation date or 2 years from motor manufacture date. Process for repairing or replacing motor depends on motor manufacturer and horsepower. Contact motor manufacturer for terms. If motor warranty is refused, use the following procedure: Have motor repair shop fill out the warranty report form as if they were providing warranty service. State on report reason for refusal. Send report, motor nameplate, and proof of purchase date (invoice from Sukup and invoice for your customer) to Sukup. Sukup will attempt to obtain warranty from motor manufacturer. Any credit obtained will be passed on. Warranty may also be obtained by returning motor to Sukup Manufacturing Co. or Distribution Center with prior authorization. **NOTE:** Sukup will not be responsible for unauthorized motor replacement or repair. Labor for removal of motor not included.

WARRANTY CERTIFICATION - Warranty must be registered within one month of product shipment from Sukup facility or customer pickup from the facility to certify warranty coverage. See QR code on back page of product manual for details.

UNAPPROVED PARTS OR MODIFICATION - This warranty remains valid unless damage occurs due to improper repair methods, use of non-compatible parts, or modifications that compromise the product's safety or functionality. In such cases, Sukup reserves the right to assess whether the warranty still applies. Sukup shall not be liable for any damage resulting from improper repairs performed by unqualified parties.

12/11/2025

I. General Safety Practices



Read manual before installing or using product. Failure to follow instructions and safety precautions in manual can result in death or serious injury. Keep manual in a safe location for future reference.



On safety decals, this symbol and the signal words Danger, Warning, Caution and Notice draw your attention to important instructions regarding safety. They indicate potential hazards and levels of intensity.



RED - DANGER indicates an imminently hazardous situation which, if not avoided, will result in death or serious injury.



ORANGE - WARNING indicates a potentially hazardous situation which, if not avoided, could result in death or serious injury.



YELLOW - CAUTION indicates a potentially hazardous situation which, if not avoided, may result in minor or moderate injury.



BLUE - NOTICE alerts you to practices unrelated to personal injury, such as messages related to property damage.

IMPORTANT: To prevent death or serious injury to you or your family, it is essential that safety decals are clearly visible, in good condition, and applied to the appropriate equipment.

FOLLOW MACHINE SAFETY DECAL MESSAGES

Carefully read this manual and all safety decals on your equipment. Safety decals must be kept in good condition. Replace missing or damaged safety decals



by contacting Sukup Manufacturing Co. by mail at PO Box 677, Sheffield, Iowa 50475; by phone at 641-892-4222; or by e-mail at info@sukup.com.

It is the responsibility of the owner/operator to know what specific requirements, precautions, and work hazards exist. It is also the responsibility of the owner/operator to inform anyone operating or working in the area of this equipment of hazards and safety precautions that need to be taken to avoid personal injury or death. Always keep children away from bins and vehicles with flowing grain.

Make no unauthorized modifications to machine. Modifications may endanger function and/or safety of unit. Keep unit in good working condition. Keep shields in place. Replace worn or missing shields free of charge by contacting Sukup Manufacturing Co.

GRAIN BIN SAFETY

Owners/operators are responsible for developing site-specific confined space entry procedures. OSHA's confined space entry procedures (29CFR 1910.146) can be found at www.osha.gov.

If you must enter bin for repair or maintenance:

- Use a safety harness, safety line and respirator
- Station another person outside of bin
- Avoid the center of the bin
- Wear appropriate personal protective equipment
- Keep clear of all augers and moving parts



DANGER: Never enter bin unless all power is locked out and another person is present. Rotating augers can dismember or kill! Flowing grain may trap and suffocate. If you enter a bin of flowing grain you can be completely submerged in grain in about 8 seconds.



Failure to heed these warnings could result in death or serious injury.

NEVER clean out bin with augers running!

When bin is nearly empty, sweep (floor) augers will travel at an increasing speed; just turning around can give augers enough time to trap you. Keep away from sweep and sump augers to avoid entanglement.

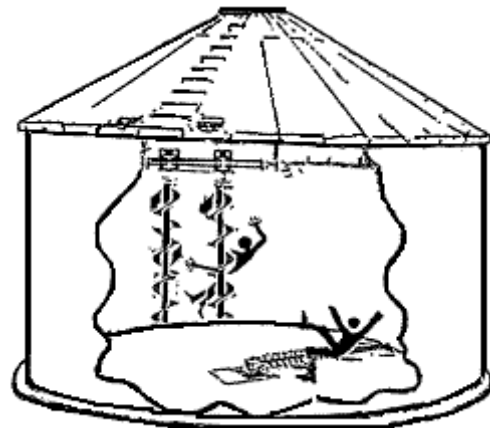

Failure to heed this warning could result in death or serious injury.

I. General Safety Practices (continued)

To avoid electrocution, all equipment must be properly wired and grounded according to electrical codes. Have unit wired by qualified electrician.

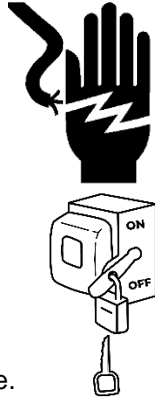

Have an electrician install a main power disconnect switch capable of being locked only in OFF position. Mark disconnect clearly as to equipment it operates.

Always lock out main power disconnect switch whenever equipment is not in use.

WARNING: When servicing equipment, never enter bin unless all power is locked out and another person is present. Always LOCK OUT all power and always check with voltage meter before servicing.

Failure to do so could result in death or serious injury.

Owners/operators are responsible for developing site-specific Lockout/Tagout procedures based on equipment at their work site. See OSHA's typical minimal lockout procedures (29CFR 1910.147 App A) at www.osha.gov.

Frequently inspect all mechanical and electrical components. Repair or replace worn parts. Ensure all electrical wires are in good condition.

WARNING: KEEP CLEAR OF ALL MOVING PARTS.

Keep people (ESPECIALLY YOUTH) away from equipment, particularly during operation.



Keep away from all moving parts. Keep all shields in place. **SHUT OFF AND LOCK OUT** all power before servicing.

Failure to follow precautions above could result in death or serious injury.

CAUTION: Metal edges are sharp. To avoid injury, wear protective clothing and handle equipment and parts with care.

Failure to do so may result in minor or moderate injury.

WARNING: If a ladder is to be placed against crosstube for installation or maintenance, securely wire outside drive end of crosstube to track to avoid movement of unit. (Be sure to remove wire when work is completed.) Failure to do so could result in death or serious injury.

WARNING: Metal is slippery when wet. To avoid falls, never carry items while climbing on bin. Maintain secure hand and foothold if climbing on bin. Failure to do so could result in death or serious injury.

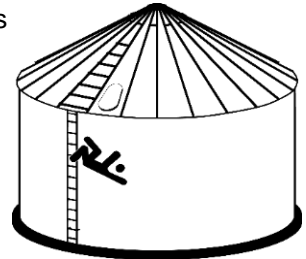

PERSONAL PROTECTIVE EQUIPMENT



Refer to OSHA 1910.132 (Personal Prot. Equip.)

Owners/Operators are responsible for developing site-specific personal protective equipment standards. OSHA's personal protective equipment standards (29CFR 1910.132) can be found at www.osha.gov.

EMERGENCIES – KNOW WHAT TO DO

Have emergency numbers and written directions to work site readily available in case of emergency. An area for emergency phone numbers to be recorded is provided below and at end of this manual.

Ambulance • Fire • Police: 9-1-1

Bin rescue team: _____

Emergency medical squad: _____

Address of work site: _____

Directions to work site: _____

II. Placement of Fastir Safety Decals

Yearly and prior to equipment use, ensure that all shields are in place and that decals are in place according to these drawings and are legible. Replace missing or damaged safety decals or shields free of charge by contacting Sukup Manufacturing Co. by mail at Box 677, Sheffield, Iowa 50475; by phone at 641-892-4222; or by e-mail at info@sukup.com.

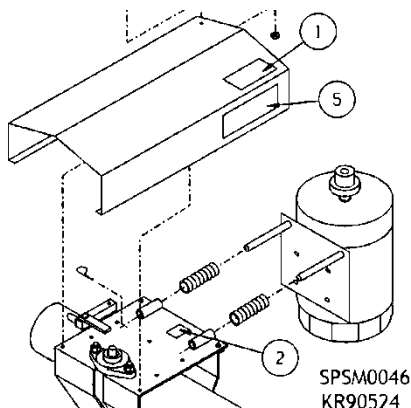

Fig. 1 – Placement of safety decals on carriages
Decals 1, 2, and 5 are factory-mounted. If their replacement is necessary, follow steps below.

- 1 Before replacing Decals 1, 2, and/or 5:
 - 1.1 Disconnect electricity.
 - 1.2 Wire end of crosstube to track.
 - 1.3 Ensure hairpin clips are through holes in motor mount.
- 2 Ensure areas of placement for decals are free from grease, oil and dirt.
- 3 Mount decals without standing under machine.



Decal 1 – L0284



Decal 5 – L0260



Decal 2 – L0271

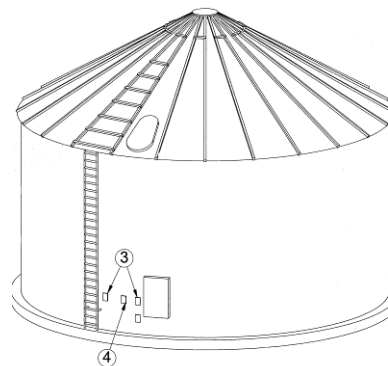

Fig. 2 – Placement of safety decals on outside of bin
Decals 3 and 4 must be mounted on-site:

- 1 Ensure areas of placement for decals are free from grease, oil, and dirt.
- 2 During machine installation, mount Decal 3 on bin sheet near door handle and at all other entry points or by ladder going up to roof so everyone entering bin will see it. See above.
 - 2.1 *Note:* If suggested areas of placement for decals are not clearly visible, place safety decals in a more suitable area. Never cover up any existing safety decals.
- 3 Mount Decal 4 on bin sheet near door handle. See above.



Decal 3 – L0258A



Decal 4 – L0281

MATERIALS REQUIRED

Before installation, ensure that all parts are present by checking Shipping List below. Also, compare carton contents against labels on cartons and ensure crosstube supplied is correct size for bin.

Shipping List

Description	Fastir				Fastir Plus		
	Qty. - Single	Qty. - Double	Qty. - Triple	Qty. - Quad	Qty. - Triple	Qty. - Quad	Qty. - Quint
Crosstube	1	1	1	1	1	1	1
Hanger pipe	1	1	1	1	1	1	1
Top hanger	1	1	1	1	1	1	1
Tie bar	--	2	2	4	2	2	2
Track	1	1	1	1	1	1	1
Down auger	1	2	3	4	3	4	5
Hardware carton 1	1	1	1	1	1	1	1
Hardware carton 2	1	1	1	1	1	1	1
Hardware carton 3	--	--	1	1	--	1	1
Stationary auger kit	--	--	--	--	1	1	1
Stabilizer arm kit	1	1	1	1	1	1	1
Gearmotor	1	1	1	1	1	1	1

Table 1 – Major parts list

Carton #	Single		Double		Triple		Triple (Fastir+)		Quad		Quad (Fastir+)		Quint (Fastir+)	
	4-1/2"	5-1/2"	4-1/2"	5-1/2"	4-1/2"	5-1/2"	4-1/2"	5-1/2"	4-1/2"	5-1/2"	4-1/2"	5-1/2"	4-1/2"	5-1/2"
1	A8490	--	A8491	A84912	A8492	A84922	A8491	A84912	A8493	A84933	A8492	A84922	A8493	A84933
2	Varies by bin diameter, motor phase & voltage													
3	--	--	--	--	A8485	A8486	--	--	A8485	A8486	--	--	--	A8486
Stationary	--	--	--	--	--	--	A3424	A34242	--	--	A3424	A34242	--	A34242

Table 2 – Fastir/Fastir Plus basic hardware carton part numbers

Description	Part #		Qty.				
	4-1/2" Crosstube	5-1/2" Crosstube	Single*	Double	Triple	Quad	Quint(**)(***)
Safety decal package	A3399	A3399	1	1	1	1	1
Stationary auger kit parts sack	A3426	A3426	--	--	--	1	1
Motor mount	A5209	A5209	1	2	3	4	4
Junction box, w/ lid	A5612	A5612	1	1	1	1	1
Flinger	A5616	A5616	1	2	3	4	4
Carriage shield*	--	A6120	--	--	--	--	4
Cord support strap	A6121	A6121	1	1	1	1, 2	2
Satellite carriage, 5-1/2"	--	A6135	--	--	--	--	1
Parts sack, single	A6806	--	1	--	--	--	--
Parts sack, double	A6807	--	--	1	--	--	--
Parts sack, triple	A6808	A6808	--	--	1	1	1
Carriage reversing plate	A80342	--	4	4	4	4	--
Carriage reversing plate, split, 5-1/2"	--	A8060	--	--	--	--	4
Primary carriage, single auger	A8500	--	1	--	--	--	--
Primary carriage	A8501	--	--	1	--	--	--
Satellite carriage	A8502	--	--	1	--	1	--
Sloped shield	A8508	--	1	2	3	4	--
Flange bearing, 1" ID, w/ LC	J0003	J0003	2	4	--	--	8
Belt, AX47	J0179	--	1	2	3	4	--
Belt, AX51	--	J0195	--	--	--	--	4
Pulley, 9" OD, 1" ID, A groove	J0355	J0355	1	2	3	4	4
Grain level warning decal	L0304	L0304	1	1	1	1	1
Sukup logo	L03171	L03171	1	1	1	1	1
Manual	L1413	L1413	1	1	1	1	1
Wire ties	L9999	L9999	1	2	3	4	4

* Only for 4-1/2"

** Only for 5-1/2"

*** Fastir+

Table 3 – Fastir/Fastir Plus basic Hardware Carton 1 contents

Description	Part #	Qty.				
		Single	Double	Triple	Quad	Quint
Chain, 1/4"	Varies	2	2	2	2	2
Rotating contact	Varies	1	1	1	1	1
Pillow-block bearing, (4-1/2" - A5649) (5-1/2" - A5651)	Varies	1	1	1	1	1
Tie bar, 19-1/2" - A5897 (28-1/2" - A59021*)	Varies	--	--	2	2	2
Bolt sack for track	Varies	1	1	1	1	1
Supplemental bolt sack for track	Varies	1	1	1	1	1
Junction box, w/ 15' 4" cord & mounting plate	A8140	--	1	1	1	1
Junction box, w/ 17' 10" cord & mounting plate	A8141	1	--	--	--	--
Adapter shaft	A75752	1	1	1	1	1
Gearmotor shield	A75191	1	1	1	1	1
Gearmotor bolt sack	A7576	1	1	1	1	1
Center hanger base	A7519-01	1	1	1	1	1
Mounting plate	A7519-02	1	1	1	1	1
Center hanger vertical strap, 30", SB	A7519-03	1	1	1	1	1
Center hanger vertical strap, 30", AS	A7519-04	1	1	1	1	1
Center hanger top	A75192	1	1	1	1	1
Bolt sack for center hanger	A75195	1	1	1	1	1
Primary carriage	A8501	--	--	1**	--	--
Satellite carriage	A8502	--	--	1**	--	--
Tilt switch	Varies	--	1	2	3	4

* Used on machines in bins 40' dia. & larger

** Used on Fastir +

Table 4 – Fastir/Fastir Plus Hardware Carton 2 contents

Description	Part #		Qty.				
	4-1/2" Crosstube	5-1/2" Crosstube	Single	Double	Triple	Quad	Quint
Primary carriage	A8501	A6130	--	--	1	1	1
Satellite carriage	A8502	A6135	--	--	2	2	2

Table 5 – Hardware Carton 3 contents (Fastir Plus only)

MAX AMPS & CIRCUIT BREAKERS

Table 6 shows maximum amps and circuit breaker size depending on number of down augers and motor hp, phase and voltage. **NOTE:** Breaker sizes are recommendations only. Check motor nameplate amperage, National Electric Code and local codes to size breakers properly.

HP	PHASE	VOLTS	NUMBER OF DOWN AUGERS									
			ONE		TWO		THREE		FOUR		FIVE	
			MAX AMPS	BREAKER SIZE*	MAX AMPS	BREAKER SIZE*	MAX AMPS	BREAKER SIZE*	MAX AMPS	BREAKER SIZE*	MAX AMPS	BREAKER SIZE*
1.5	1	230	9	15	18	35	27	60	35	70	44	80
2	1	230	10	20	19	35	28	60	38	80	47	80
1.5	3	230	6	15	10	20	15	30	20	40	25	45
1.5	3	460	3	15	6	15	8	15	10	20	13	25

Table 6 – Maximum amp & circuit breaker sizes

ASSEMBLY & INSTALLATION

I. Installing Track

See Page 61 to identify parts referenced in this section.

Track is most easily installed while first ring of bin is being assembled on ground. Track of correct size must be installed as a unit in bin. Track brackets and curvature vary according to bin diameter.

Track installation process for Sukup bin sheets with factory-punched mounting holes differs slightly from process used with other bin sheets. Section A describes process used with Sukup track-punched bin sheets. Section B describes process used with Sukup bin sheets not punched for track and for bin sheets from other companies.

With bin sheets produced by other companies, existing holes in top bin sheets may be used for mounting track in many cases (Section B). However, in some cases, no holes will match and all holes must be drilled in bin sheet to mount track. Section C describes this process.

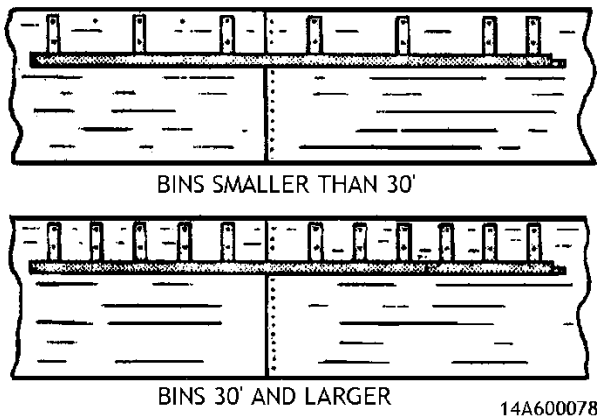

Fig. 3 – Track bracket placement

A. Installing Track on Sukup Bin Sheets Punched for Track

- A1 For Sukup bins smaller than 30' diameter, insert 5/16" x 1-1/4" bolts in top hole of every other pair of bolt holes around top of bin (approximately 18" spacing). For Sukup bins 30' and larger, place bolts in top hole of every pair of bolt holes (approximately 9" spacing) except those at bin wall seam. See Figs. 3 & 4.
- A2 Mount one length of track with bolts through top holes on track brackets. See Figs. 3 & 4.
 - A2.1 *Note:* On bins 30' and larger with a double-bracketed track, a gap has been left to prevent interference between seam bolts and track brackets. Install first section of track with seam in place of missing bracket. See Fig. 3.

- A3 Insert 5/16" x 1" bolts through bottom holes on track brackets.
- A4 Place 5/16" nuts onto bolts through track bracket. Do **not** tighten at this time. See Fig. 4.

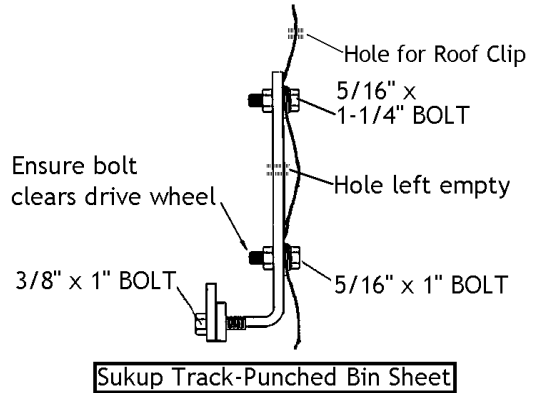

Fig. 4 – Side view of track mounted on Sukup bin sheet punched for track

- A5 Mount remaining track sections using Steps A2-A4, joining track sections together with 3/8" x 1" bolt and 3/8" lock washer and nut. Tighten using 9/16" wrench. See Fig. 5.
 - A5.1 *Note:* Ensure these bolts are pointing to outside (toward bin sidewall) to avoid obstructing machine movement.

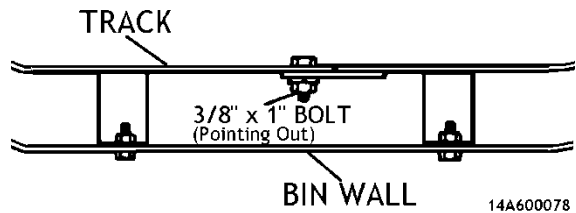

Fig. 5 – Top view of track splice

- A6 Tighten 5/16" nuts on bolts through track bracket using 1/2" wrench.
- A7 Ensure entire length of track and bin wall is free of any obstructions that could hinder movement of machine through bin.

B. Installing Track on Sukup Bin Sheets Not Punched for Track and on Bin Sheets from Other Companies

- B1 For bins smaller than 30', insert 5/16" x 1-1/4" bolts in single ring of bolt holes around top of bin (approximately 18" spacing). For bins 30' and larger, place bolts in every bolt hole (approximately 9" spacing) except those at bin wall seam. See Fig. 3.
- B2 Tighten 5/16" spacer nuts onto these bolts. See Fig. 6.
- B3 Mount first segment of track over bolts and screw on a second 5/16" nut. See Figs. 3 & 6.

B3.1 *Note:* On bins 30' and larger with a double-bracketed track, a gap has been left to prevent interference between vertical seam on sidewall sheets and track brackets. Install first section of track with bin wall seam in place of missing bracket. See Fig. 3.

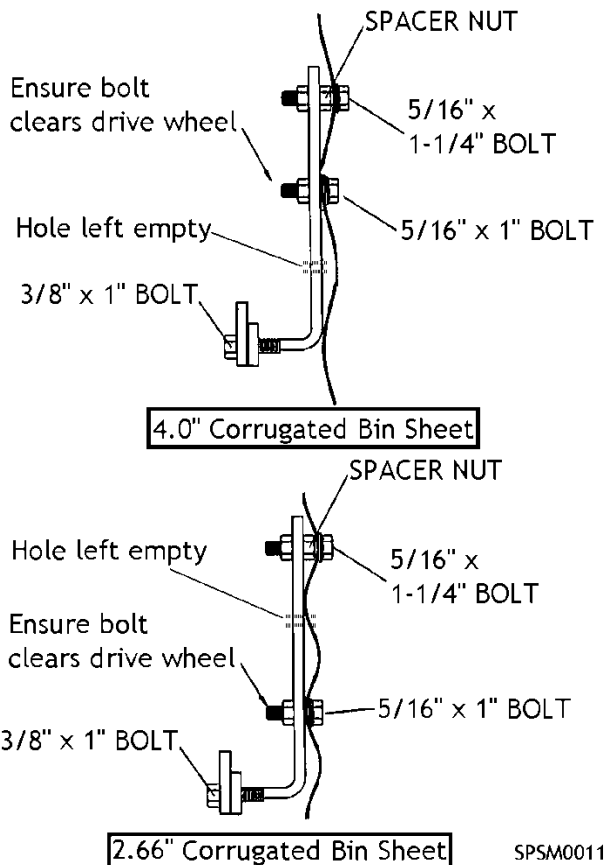

Fig. 6 – Side view of track mounted on Sukup bin sheets not punched for track, and on sheets from other companies

B4 Mount remaining track sections using Steps B2-B3, joining track sections together with 3/8" x 1" bolt and 3/8" lock washer and nut. Tighten using 9/16" wrench. See Fig. 5.

B4.1 *Note:* Ensure these bolts are pointing to outside (toward bin sidewall) to avoid obstructing machine movement.

B5 After all track sections are in place, drill second, lower bolt holes through bin sheets using track brackets as pattern. See Fig. 3.

B5.1 *Note:* Drill through **middle** bracket holes only when dealing with 4.0" cor. sidewall sheet.

B5.2 *Note:* Drill through **bottom** bracket holes only when dealing with 2.66" cor. sidewall sheet.

B6 Insert 5/16" bolt **no longer than 1"** into newly drilled holes. If needed, insert a longer bolt pointed to outside to avoid obstructing machine

movement and screw on 5/16" nuts. Tighten using 1/2" wrench.

B6.1 *Note:* Leave unused track bracket holes empty. See Fig. 6.

B7 Tighten 5/16" nuts on top bolts through track brackets using 1/2" wrench.

B8 Ensure entire length of track and bin wall is free of any obstructions that could hinder movement of machine through bin.

C. Installing Track When Holes for Track Brackets Must Be Drilled

C1 Place first segment of track in bin.

C2 Drill holes in top bin sheet to match holes on each bracket:

C2.1 When drilling 4.0" Cor. sidewall sheets, use top and bottom track bracket holes as guide as shown in Fig. 4.

C2.2 When drilling 2.66" Cor. sidewall sheet, use bracket holes as guide to drill through corrugation hills on sheet.

C3 Insert 5/16" x 1-1/4" bolt through top bolt holes. See Fig. 6.

C4 Mount first segment of track over bolts and screw on 5/16" nuts. See Fig. 6.

C5 Insert 5/16" x 1" bolts in lower holes of track bracket and add 5/16" nuts. Tighten using 1/2" wrench. See Fig. 6.

C5.1 *Note:* Leave unused track bracket holes empty. See Fig. 6.

C6 Mount remaining track sections using Steps C2-C5, joining track sections together with 3/8" x 1" bolts and 3/8" lock washers and nuts. Tighten using 9/16" wrench. See Fig. 5.

C6.1 ***Note:* Ensure these bolts are pointing to outside (toward bin sidewall) to avoid obstructing machine movement.**

C6.2 *Note:* Due to variations in bin diameters, it may be necessary to use a splice to join last section of track. These splice sections (A5718) are available at no charge by contacting Sukup Manufacturing Co. by mail at Box 677, Sheffield, Iowa 50475; by phone at 641-892-4222; or by e-mail at info@sukup.com.

C6.3 If splice is required, bolt splice section in place and tighten. Splice is 18-1/2" long. Trim as needed.

C7 Ensure entire length of track and bin wall is free of any obstructions that could hinder movement of machine through bin.

II. Assembling & Installing Carriages

See Pages 65-71 to identify parts referenced in this section.

- 1 Carry crosstube and hardware into bin.
- 2 Place outside crosstube end with drive wheel next to bin sidewall and inside end with shaft in center of bin.

For Fastir Plus units, begin here and continue following instructions:

- 3 Bolt stationary carriage plate onto drive wheel end of crosstube with hub pointing outward using 3/8" x 1-3/4" bolts and 3/8" washers and nuts. See Figs. 7 & 13.

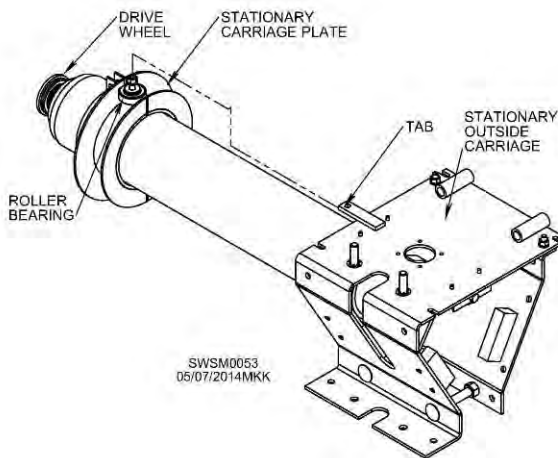

Fig. 7 – Placement of stationary outside carriage on Fastir Plus

- 4 Slide stationary outside carriage onto crosstube beside plate with reversing mechanism tab pointing toward drive wheel. See Figs. 7 & 13.

For multiple-carriage regular Fastir units, begin here and continue following instructions:

- 5 Slide satellite carriage(s) onto crosstube from inside, shaft end with reversing mechanism tab pointing toward drive wheel, as shown in Fig. 7.

For single-carriage Fastir units, begin here:

- 6 Slide primary carriage about 1 foot onto crosstube from inside, shaft end. Knurled bearing should be on top and slot for down auger on front of crosstube as shown in Figs. 7 & 8.
- 7 Ensure 1/16" gaps (approximately the thickness of a credit card) exist between crosstube and bearing blocks. See Fig. 8.

Note: If necessary, adjustments may be made using 3/4" wrench on bottom carriage bolts. **Do not overtighten carriages.**

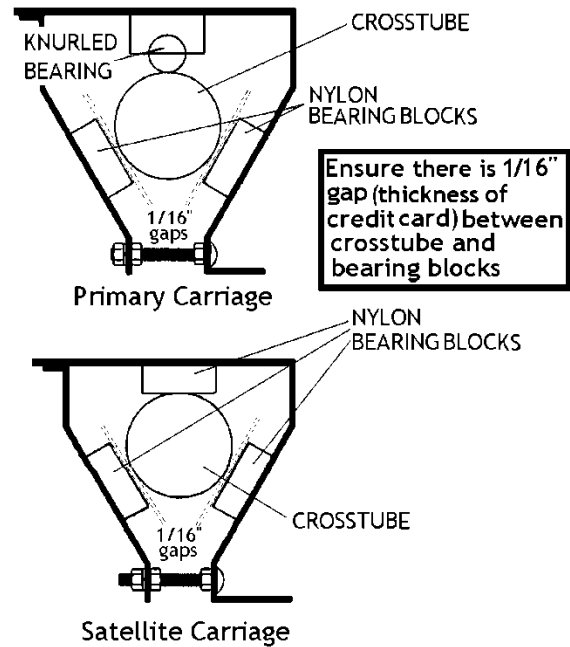

Fig. 8 – Side view of primary & satellite carriages

- 8 See applicable table and drawing on Pages 15-17 to determine correct spacing between carriages, comparing hole-to-hole lengths.
- 9 Bolt tie bar to lower inside of back plates on carriages as shown in Fig. 9. Use 5/16" x 1" bolts pointing inward, one stabilizer arm bracket (A4545), and 5/16" lock washers and nuts. Tighten using 1/2" wrench.

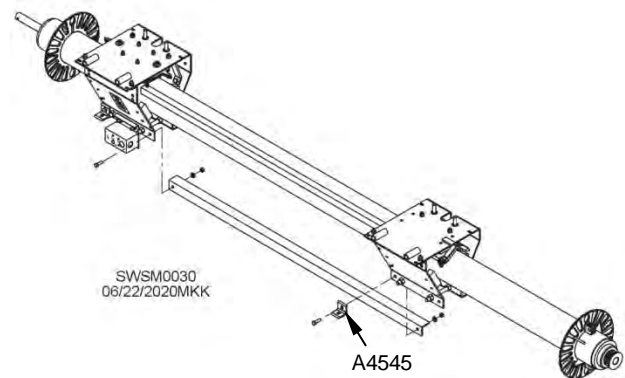
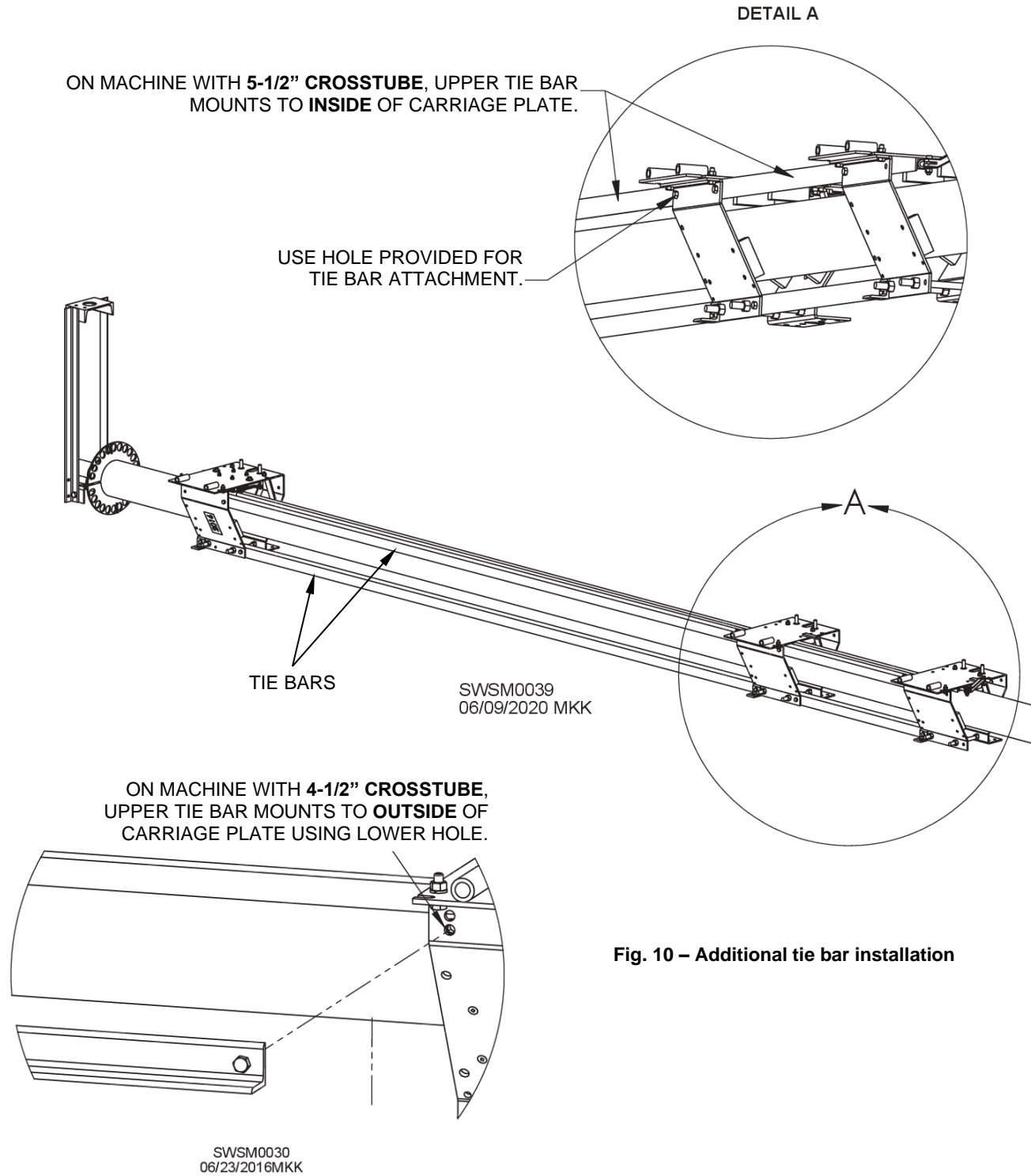

Fig. 9 – Backside view of Fastir tie bar installation

INSTALLING ADDITIONAL TIE BAR

9A On all Fastir sizes, install additional tie bar on back inside of carriage near top as shown in Fig. 10.

9B Install additional tie bar(s) between other moving carriages in same manner. See Fig. 10.



PRIMARY CARRIAGE

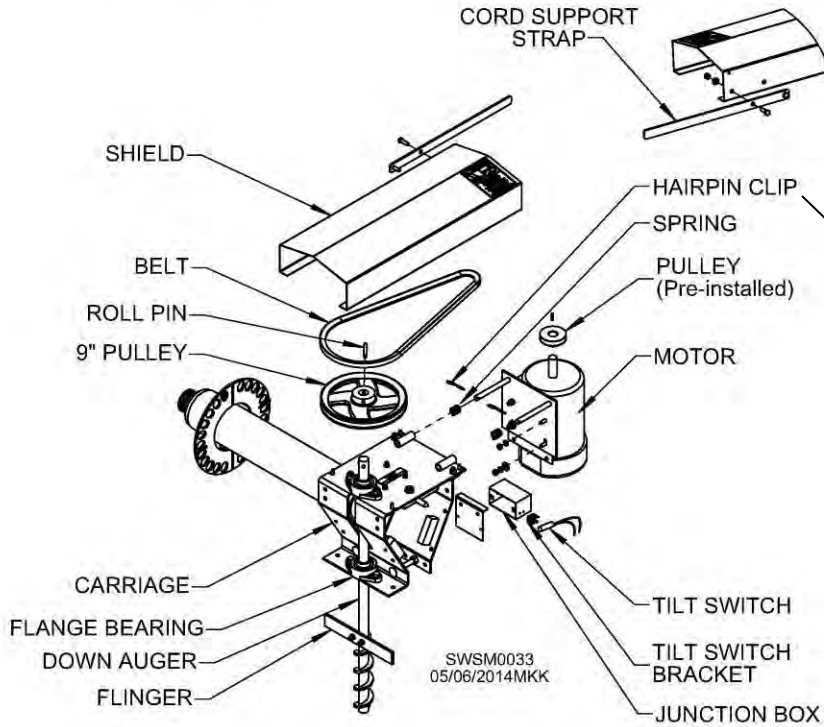

WARNING:
 To prevent death or serious injury be sure that hairpin clips are inserted in motor mount so motor will not fall unexpectedly.

SATELLITE CARRIAGE

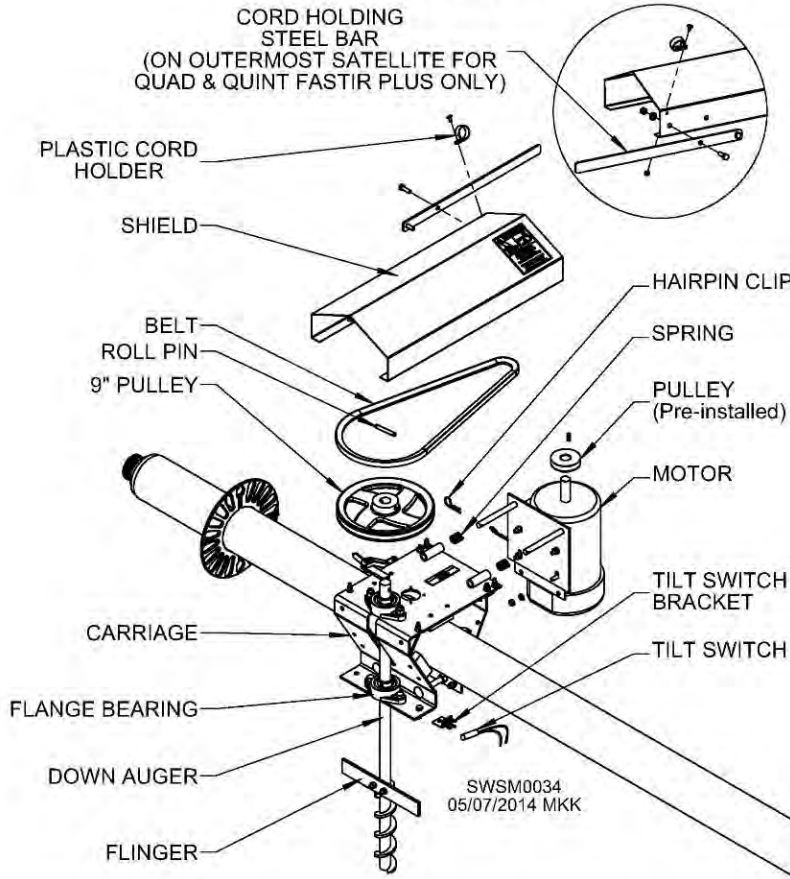

Fig. 11 – Exploded views of primary & satellite carriage assemblies

Fastir Assembly

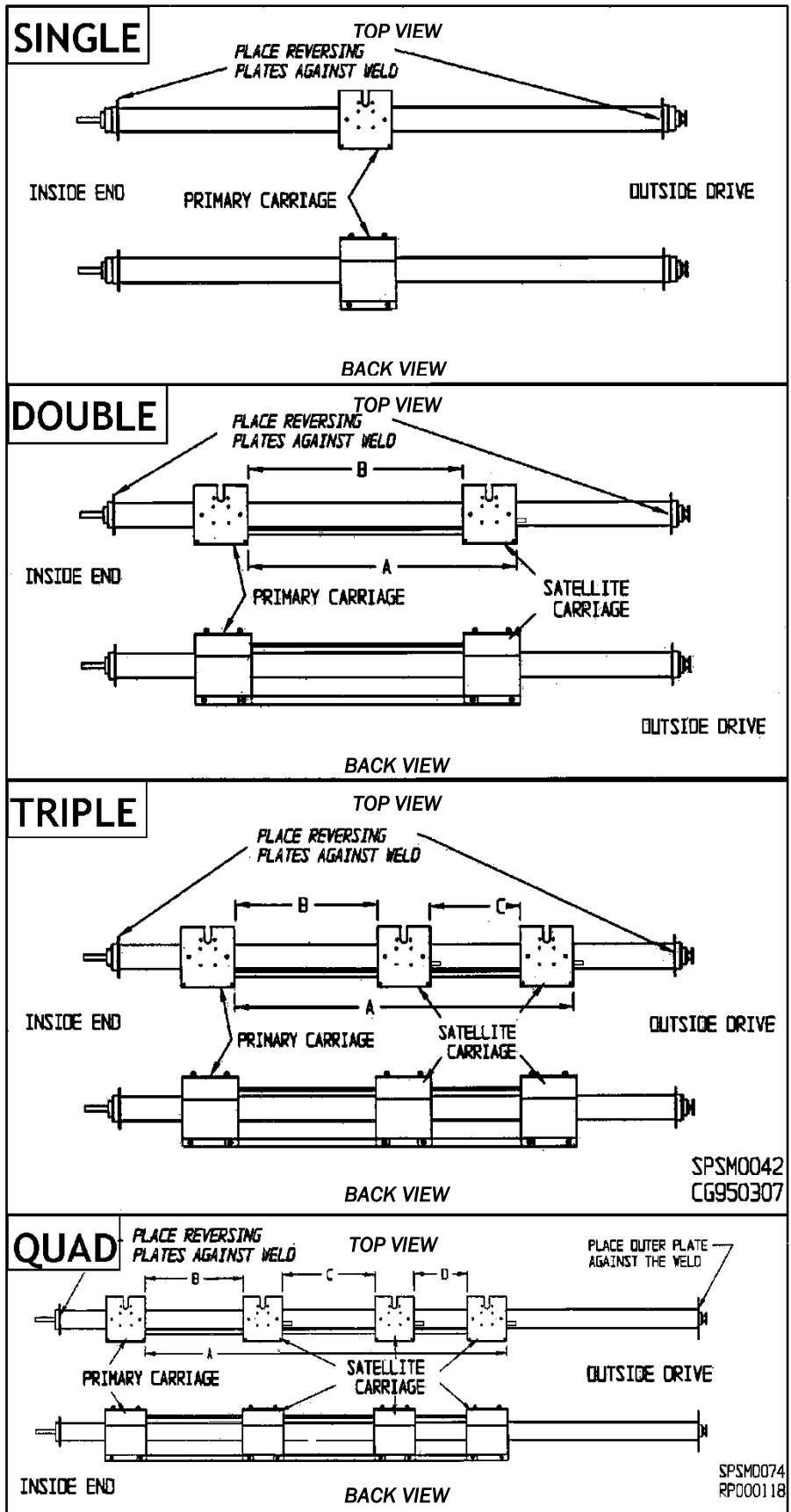

Fig. 12 – Tie bar & carriage placement for Fastir (See Table 7 for part #s & dimensions)

Fastir

Double Auger					Triple Auger					
Bin Diameter	Reversing Rod Hole-to-Hole*		Tie Bar Hole-to-Hole**		Reversing Rod Hole-to-Hole*		Tie Bar Hole-to-Hole**			
	(A)		(B)		(A)		(B)		(C)	
	Part #	Length	Part #	Length	Part #	Length	Part #	Length	Part #	Length
18' - 18' 7"	A8514	46	A59051	37	A85231	59.5	A5901	24	A5897	18
21' - 21' 8"	A8523	55.5	A59071	46	A85152	68.5	A5904	33	A5897	18
24' - 24' 9"	A85143	61.5	A59081	52	A85261	77	A59061	41	A5897	18
27' - 27' 10"	A8526	70.5	A59110	61	A8522	88	A59081	52	A5897	18
30' - 31'	A8527	83.5	A81151	74	A8518	96.5	A59110	61	A5897	18
33' - 34'	A85282	90.5	A59124	81	A8529	102	A59116	66	A5897	18
36' - 37' 1"	A8529	102	A59141	93	A85302	112.75	A59121	77	A5897	18
42' - 42' 8"	A8532	118.5	A5916	109	A8533	137.5	A59141	93	A59021	27
48'	-	-	-	-	A85333	153.75	A5916	109	A59021	27
49' 3"	-	-	-	-	A85333	153.75	A5916	109	A59021	27
Quadruple Auger										
Bin Diameter	Reversing Rod Hole-to-Hole*		Tie Bar Hole-to-Hole**							
	(A)		(B)		(C)		(D)			
	Part #	Length	Part #	Length	Part #	Length	Part #	Length		
27' - 27' 10"	A8529	102	A59032	29	A59032	29	A5897	18		
30' - 31'	A8532	118.5	A59051	37	A59051	37	A5897	18		
33' - 34'	A85321	127	A59061	41	A59061	41	A5897	18		
36' - 37' 1"	A85324	136	A59071	46	A59071	46	A5897	18		
42' - 42' 8"	A8537	165	A5910	56	A5910	56	A59021	27		
48'	A85381X	196.5	A5912	71	A5912	71	A59021	27		

*Hole-to-hole measurement is with adjustable spade bolt; cut length of reversing rod 1-1/2" shorter than hole-to-hole measurement.

**Cut length of tie bar 1-1/2" longer than hole-to-hole measurement.

Table 7 – Hole-to-hole lengths (measured in inches from hole centers) for Fastir tie bars & reversing rods

Fastir Plus

Triple Auger (1 Stationary)					Quadruple Auger (1 Stationary)					
Bin Diameter	Reversing Rod Hole-to-Hole*		Tie Bar Hole-to-Hole**		Reversing Rod Hole-to-Hole*		Tie Bar Hole-to-Hole**			
	(A)		(B)		(A)		(B)		(C)	
	Part #	Length	Part #	Length	Part #	Length	Part #	Length	Part #	Length
18' - 18' 7"	A85140	36.5	A59021	27	-	-	-	-	-	-
21' - 21' 8"	A8514	46	A59051	37	-	-	-	-	-	-
24' - 24' 9"	A8523	55.5	A59071	46	A85153	68.75	A5904	33	A5897	18
27' - 27' 10"	A8515	66	A5910	56	A85261	77	A59061	41	A5897	18
30' - 31'	A85260	75.5	A59116	66	A8522	88	A59081	52	A5897	18
33' - 34'	A85383	80.5	A5912	71	A8519	97	A59110	61	A5897	18
36' - 37' 1"	A85282	90.5	A59124	81	A85300	106.75	A5912	71	A5897	18
42'	-	-	-	-	A85322	130.75	A59131	86	A59021	27
Quintuple Auger (1 Stationary)										
Bin Diameter	Reversing Rod Hole-to-Hole*		Tie Bar Hole-to-Hole**							
	(A)		(B)		(C)		(D)			
	Part #	Length	Part #	Length	Part #	Length	Part #	Length		
42' - 42' 8"	A85361	157	A59081	52	A59081	52	A59021	27		
48'	A8539	185	A59116	66	A59116	66	A59021	27		
49' 3"	A85382	185	A59116	66	A59116	66	A59021	27		

*Hole-to-hole measurement is with adjustable spade bolt; cut length of reversing rod 1-1/2" shorter than hole-to-hole measurement.

**Cut length of tie bar 1-1/2" longer than hole-to-hole measurement.

Table 8 – Hole-to-hole lengths (measured in inches from hole centers) for Fastir Plus tie bars & reversing rods

Fastir Plus Assembly

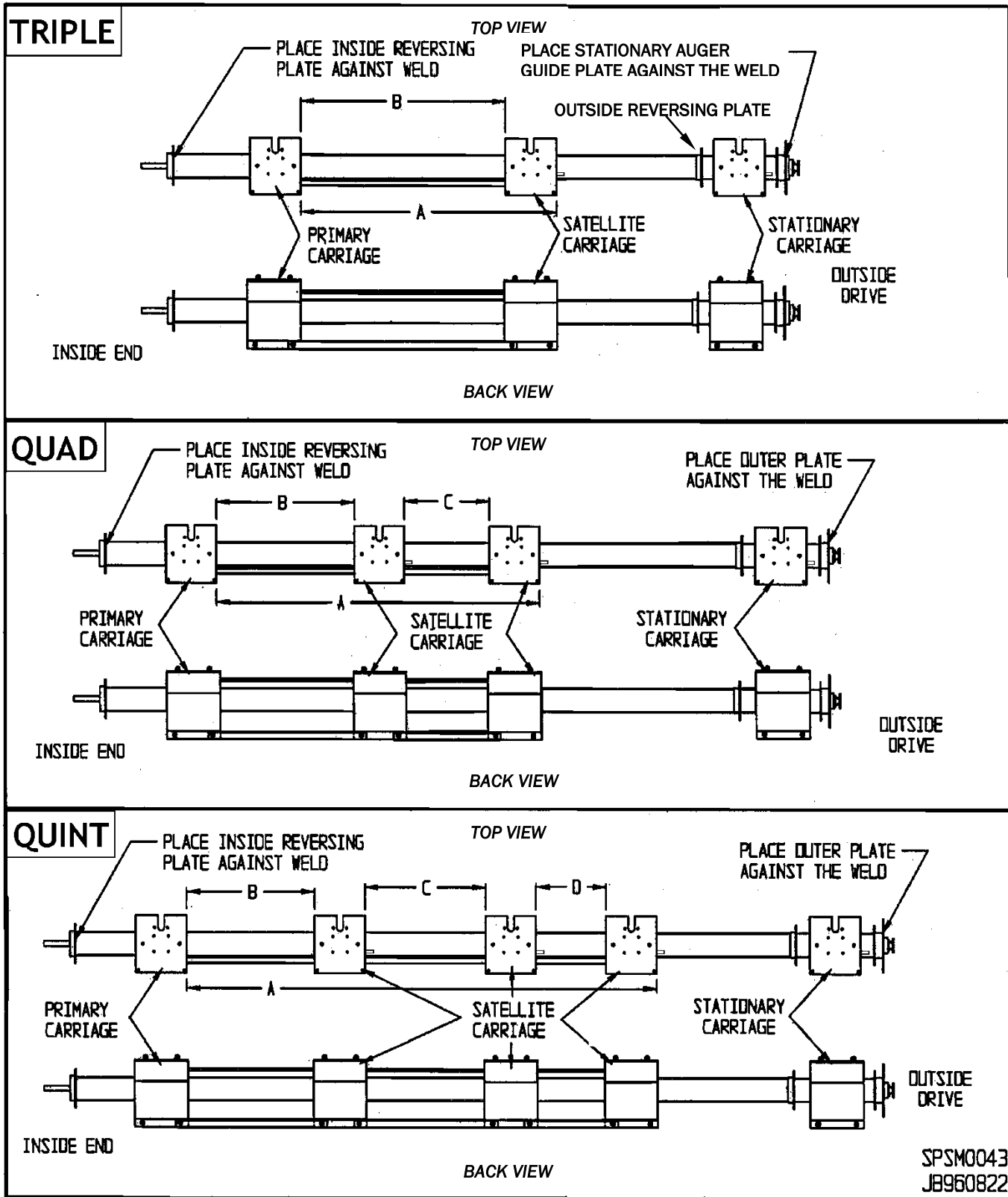
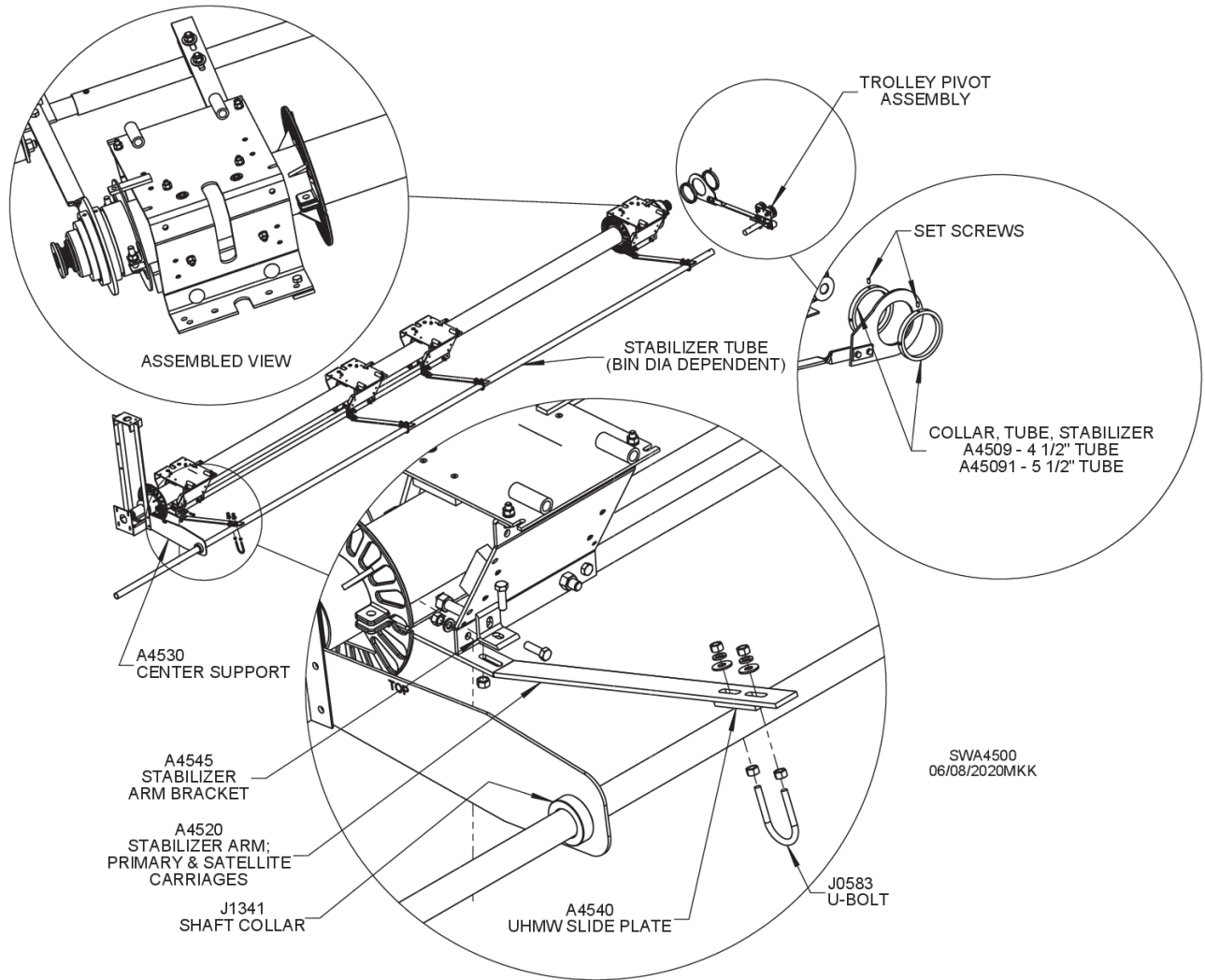

Fig. 13 – Tie bar & carriage placement for Fastir Plus (See Table 8 for part #s & dimensions)

III. Installing Stabilizer Arm Kit



SWA4500
06/08/2020MKK

Fig. 14 – Stabilizer arm assembly on quad unit

- 10 Installation of stabilizer arm requires that brackets be attached to all carriages (primary, satellite and, if present, stationary outside carriages). All three types of carriages use the same brackets, which are supplied by Sukup Manufacturing Co.
- 11 Bolt center support to center hanger using two (2) 3/8" holes in center hanger. Ensure bottom of center support is flush with bottom of center hanger assembly. Word "TOP" is etched on center support (A4530) to aid in positioning.
- 12 Attach stabilizer arm bracket (A4545) to primary and satellite carriages as shown above.
- 13 Adjust U-bolts on stabilizer tube so they are loose enough to allow primary and satellite carriages to slide freely.
- 14 Assemble trolley as shown on next page.

Stabilizer Kit Trolley Pivot Assembly

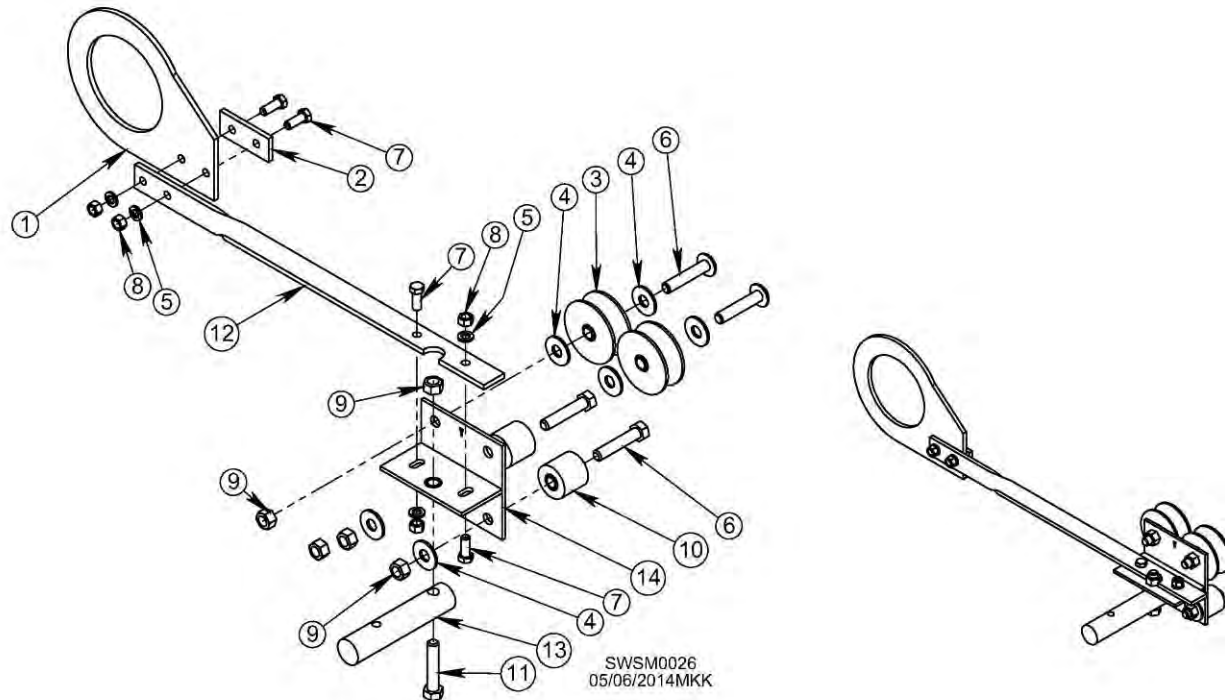

Fig. 15 & Table 9 – Exploded view & parts list for stabilizer kit trolley pivot assembly

Ref. #	Description	Qty.	Part #
1	Trolley bracket plate, 4-1/2", UHMW	1	A4517
	Trolley bracket plate, 5-1/2", UHMW	1	A45171
2	Trolley bracket cover	1	A4518
3	Trolley wheel, w/ bushings	2	A6048
3A	Bushing, 1/2" x 3/4" x 3/4"		J0073
3B	Bushing, 1/2" x 3/4" x 1/2"		J0072
4	Flat washer, 1/2"	6	J1125
5	Lock washer, 3/8"	4	J1205
6	Screw, 1/2 – 13 x 2-1/2"	5	J07463
7	Screw, 3/8 – 6 x 1-1/4"	4	J0616
8	Hex nut, 3/8" - 16	4	J1020
9	Lock nut, 1/2" - 13	5	J1042
10	Trolley roller, w/ bushings	2	A6049
10A	Bushing, 1/2" x 3/4" x 1"		J0074
10B	Bushing, 1/2" x 3/4" x 1/2"		J0072
11	Screw, 1/2 – 13 x 2-1/2"	3	J07463
12	Trolley bracket bar	1	A45161
13	Trolley connection shaft	1	A45131-01
14	Trolley bracket weldment	1	A45122

- 15 If trolley comes pre-assembled, skip to Step 20.
- 16 Add a 1/2" flat washer to each 1/2" x 2-1/2" bolt and slide a top trolley pulley onto each, adding second 1/2" flat washer on outside of pulleys. See Fig. 15.
- 17 Insert 1/2" x 2-1/2" bolt through roller assembly. See Fig. 15.
- 18 Add 1/2" lock nut to each bolt. See Fig. 15.
- 19 Insert 1/2" x 2-1/2" bolt through hole on connecting shaft and slide up through center

extended hole on weldment bracket. Add 1/2" lock nut. See Fig. 15.

- 20 Insert 3/8" x 1-1/4" bolts through 2 holes trolley bracket cover, bracket plate, and bracket bar, adding 3/8" lock washers and nuts. See Fig. 15.
- 21 Bolt bracket bar to weldment bracket using 2 3/8" x 1-1/4" bolts pointing down through assembly. Add 3/8" lock washer and nut. See Fig. 15.
- 21.1 *Note:* Bracket plate fits over crosstube.
- 22 Tighten all hardware. Ensure roller turns freely.

IV. Installing Tilt Switches

See Pages 65-71 to identify parts referenced in this section.

- 23 Bolt junction box with attached tilt switch onto bottom of motor side of primary carriage using 5/16" x 1" bolts (pointing out through carriage) and 5/16" lock washers and nuts provided on junction box. Tighten using 1/2" wrench. See Fig. 16.

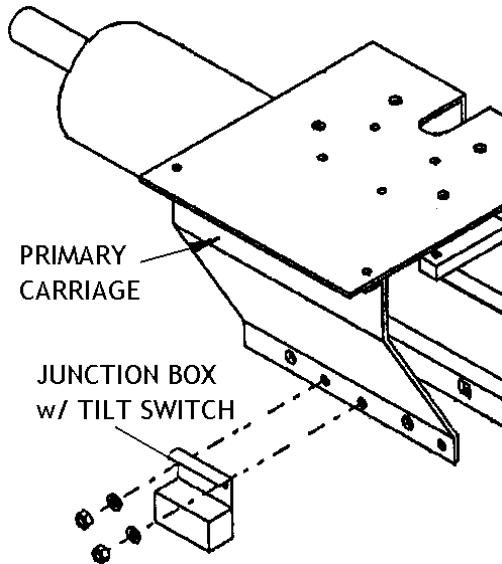

Fig. 16 – Tilt switch placement on primary carriage

- 24 On satellite and stationary outside carriages (if present), bolt tilt switches to bottom auger side of carriages near down auger slots (facing in). Use 5/16" x 1" bolt pointing down through plate and 5/16" lock washer and nut. See Fig. 17.

SATELLITE OR STATIONARY CARRIAGE

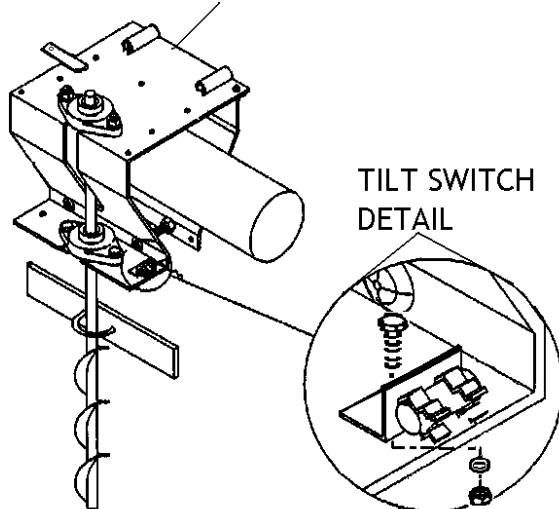

Fig. 17 – Tilt switch placement on satellite & stationary carriages

- 25 Align tilt switch with carriage edge and tighten using 1/2" wrench.

V. Installing Motors

See Pages 66-71 to identify parts referenced in this section.

- 26 Slide springs from hardware sack onto each rod on motor mount(s). See Fig. 18.

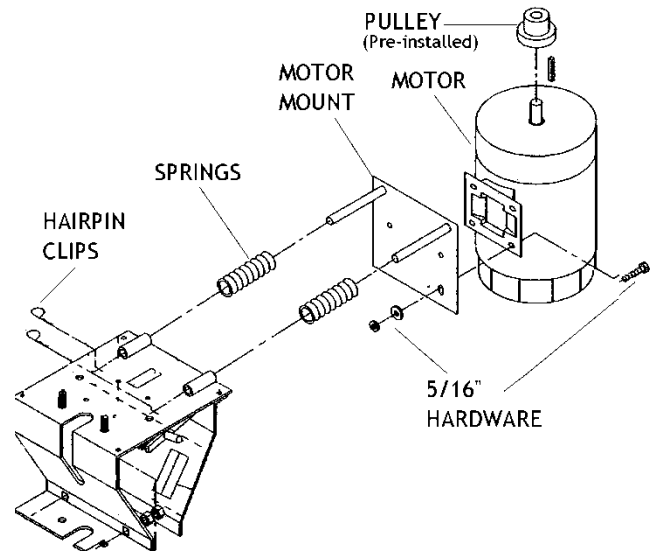

Fig. 18 – Motor installation

- 27 Bolt appropriate motor for each carriage onto motor mount with motor pulley facing up. Use 5/16" x 1" bolts and 5/16" flat washers, lock washers, and nuts and tighten with 1/2" wrench. See Fig. 18.
- 28 Slide motor mount rods through tubes welded onto carriages from outside of carriage. See Fig. 18.
- 29 Attach motor mount to carriage by inserting hairpin clips from hardware sack into holes on ends of motor mount rods. See Fig. 18.



DANGER: Failure to secure motor mount with hairpin clips could result in motor falling off machine if belt is not attached, causing death or serious injury.

- 29.1 *Note:* Sequences of motors (beginning with primary carriage and moving outward) are as follows (See Page 75 for motor component numbers):

- **Single-Auger Machine:** S
- **Double-Auger Machine:** A-O
- **Triple-Auger Machine, Single Phase:** A-O-O
- **Triple-Auger Machine, Three Phase:** A-B-O
- **Quadruple-Auger Machine:** A-O-B-O
- **Quintuple-Auger Machine:** A-B-O-B-O

VI. Installing Reversing Plates

See Pages 65-67 to identify parts referenced in this section.

- 30 On both ends of crosstube, position reversing plates vertically against weldment on each side of crosstube. See Fig. 19.
- 30.1 On Fastir Plus, position reversing plates on inside of stationary carriage.
- See Fig. 11 for assembled view.
- 31 Bolt reversing plates together using 3/8" x 1-3/4" bolts and 3/8" lock washers and nuts. Tighten using 9/16" wrench. See Fig. 19.

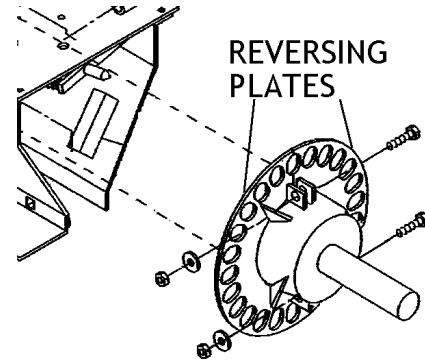

Fig. 19 - Reversing plate installation

VII. Installing Center Hanger & Related Parts

See Pages 62-63 to identify parts referenced in this section.

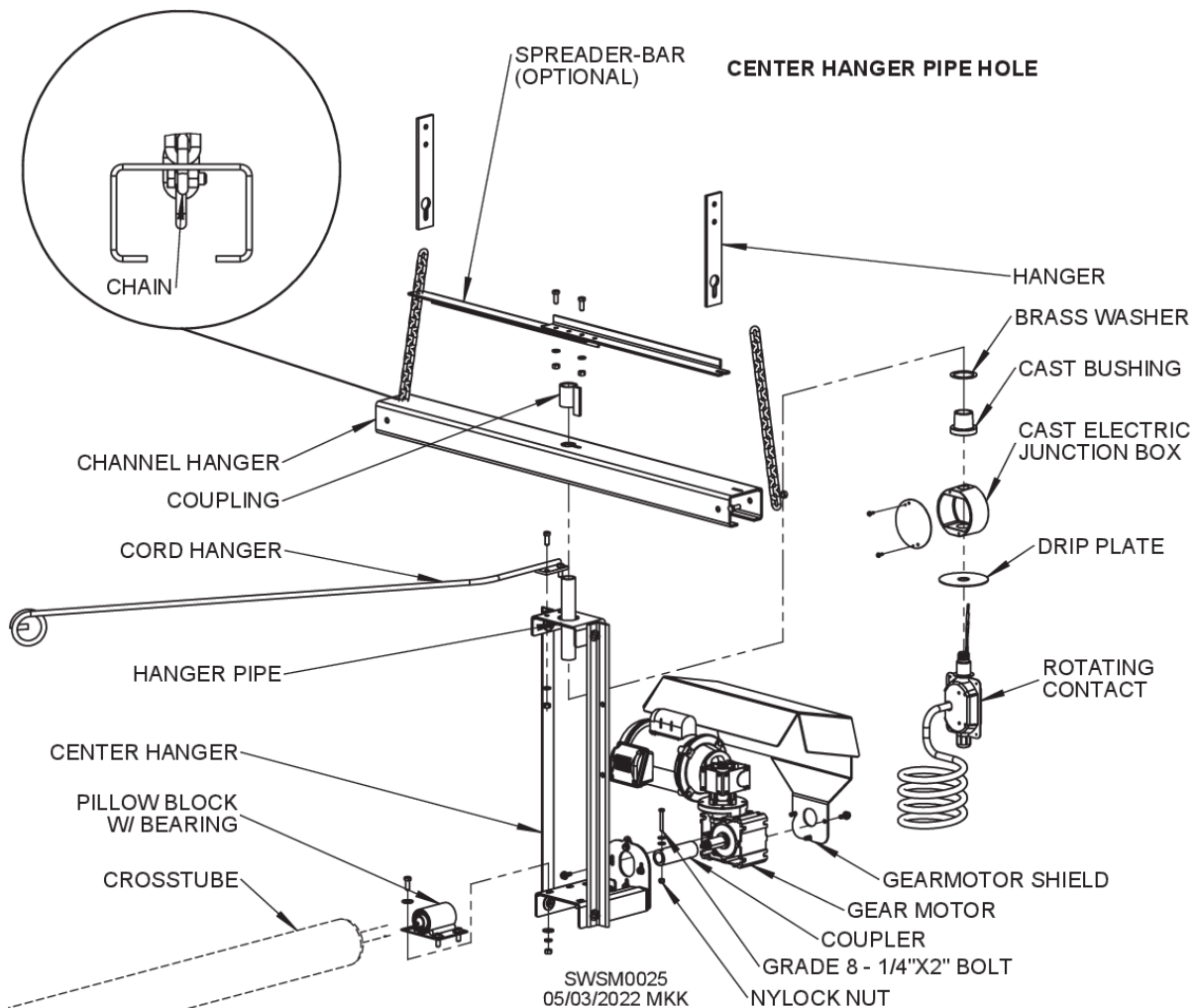

Fig. 20 – Center hanger assembly

*Note: Center hanger will not hang straight up and down due to new pivoting hanger. This is normal and will not affect performance.

- 32 Slide pillow-block bearing onto crosstube shaft. Do not tighten setscrews at this time.
- 33 Attach pillow-block bearing to center hanger with 3/8" x 1" bolts and 3/8" flat washers, lock washers and nuts. Do not tighten until gearmotor alignment is correct (Step 37). See Fig. 20.
- 34 Slide 1" coupler tube over crosstube shaft. Insert 1/4 x 2" bolt, with both 1/4" flat washers between coupler and bolt head. Secure with 1/4" lock nut.

- 35 Place gearmotor shaft in coupler and attach gearmotor assembly to center hanger using M8 bolts. Tighten bolts using 1/2" wrench. See Fig. 20
- 36 Attach gearmotor shield using M8 bolts. See Fig. 20
- 37 Ensure gearmotor and crosstube are aligned and that pillow-block bearing and center hanger do not touch tube. **DO NOT ATTEMPT TO ADJUST** gearmotor shaft by tapping on shaft with a hammer.
- 38 Tighten 4 setscrews in pillow-block bearing (2 on each end) using 1/8" hex wrench. Tighten bolts (Step 33) using 9/16" wrench. See Fig. 20.
- 39 Screw hanger pipe tightly into 1" threaded hole on cast electric junction box.
 - 39.1 **Note: Ensure threads are fully engaged, as they will hold weight of stirring machine. See Fig. 20.**
- 40 Slide cast bushing and brass washer onto hanger pipe so they rest on junction box. See Fig. 20.
- 41 Slide end of hanger pipe up through bottom of hole in center hanger so junction box is inside center hanger. See Figs. 20 & 21.

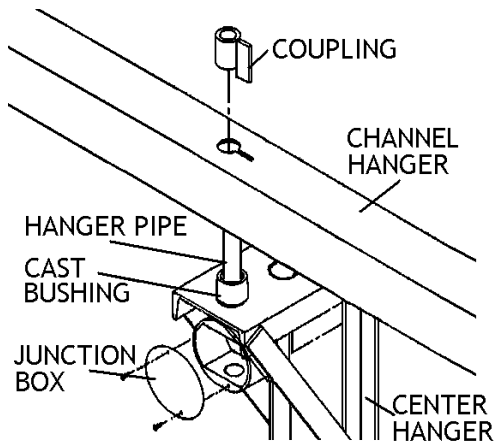

Fig. 21 - Placement of junction box on center hanger

- 41.1 **Note: Do not thread rotating contact into cast electric junction box until machine is raised in bin.** See Page 30 for rotating contact instructions. Failure to heed this note can result in rotating contact binding and breaking.

- 42 Slide channel hanger over hanger pipe. See Figs. 20 & 21.
- 43 Screw coupling onto hanger pipe ensuring tab on coupling fits in slot on channel hanger. See Figs. 20 & 21.
- 44 Thread a liquid-tight elbow (not provided) into top of coupling. Ensure threads are seated properly and tighten well. See Fig. 20.

- 45 Bolt chains onto each end of channel hanger using 3/8" x 1" bolt and 3/8" nut. Tighten using 9/16" wrench. See Figs. 20 & 21.
 - 45.1 *Note:* Center hanger will hang slightly tilted. This is normal.

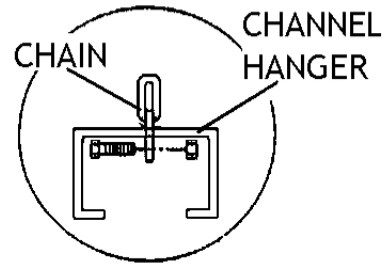

Fig. 22 – Chain placement in channel hanger

- 46 Bolt cord hanger to top of center hanger with 5/16" x 1" bolts. Tighten using 1/2" wrench. See Fig. 23.

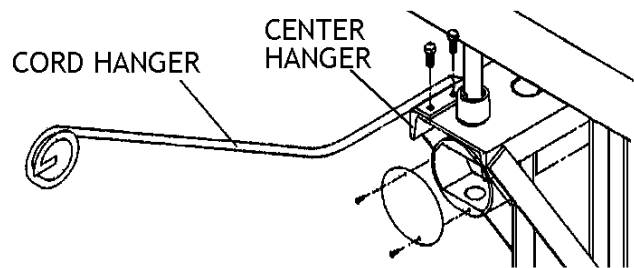

Fig. 23 – Attaching cord hanger on Fastir

- 46.1 **Fastir Plus Only:** Bolt cord hanger to bottom plate of stationary outside carriage using existing 1/2" carriage tightening bolts (double nut). See Fig. 24.
- 46.2 *Note:* Position cord hanger behind direction of travel of crosstube to keep cords away from augers.

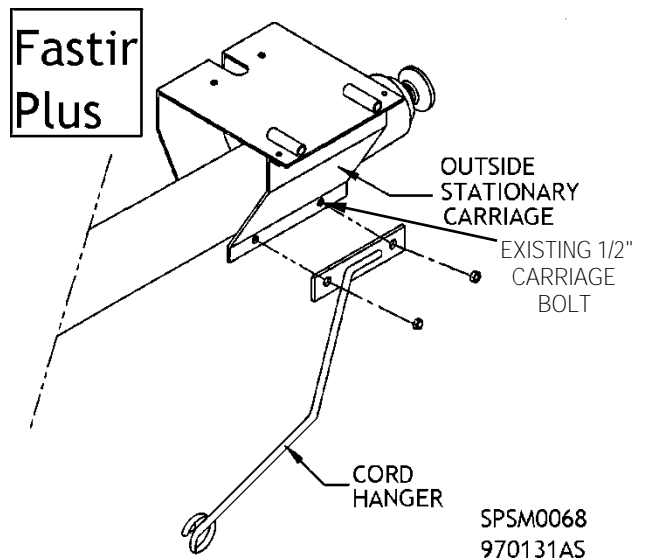

Fig. 24 – Attaching cord hanger on Fastir Plus

SPSM0068
970131AS

VIII. Installing & Adjusting Reversing Mechanism

See Page 64 to identify parts referenced in this section.

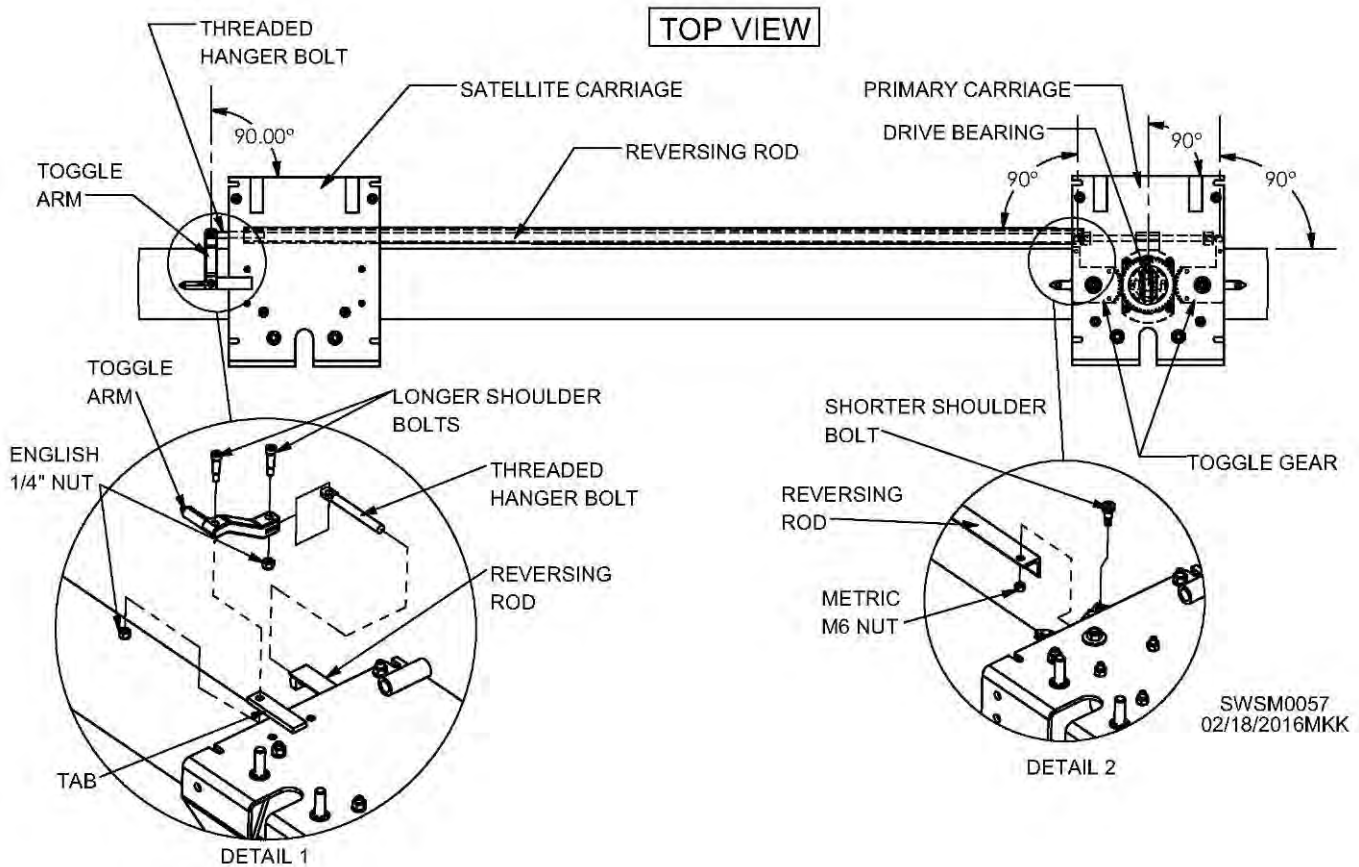

Fig. 25 – Reversing mechanism installation & adjustment

47 Ensure reversing mechanism (located on inside top of primary carriage) is timed properly by tripping reversing mechanism out of locking position and moving toggle gears to a “centered” position. See Fig. 25.

47.1 *Note:* In centered position, all components should be parallel with edge of carriage and each other. When timed properly, reversing rod toggle gear (gear closest to bin wall), drive bearing, and primary toggle gear should all be perfectly parallel to edge of carriage. See Figs. 41 & 42.

See Page 32 for reversing mechanism troubleshooting instructions.

48 On satellite carriage closest to bin wall, bolt toggle arm from parts sack to **top** of tab extending beyond carriage shell using a 5/16” shoulder bolt and 1/4” locking nut. Ensure toggle arm is parallel with edge of satellite carriage **while drive bearing is centered**. See Fig. 25, Detail 1.

49 Feed end of reversing rod with threaded bolt hole through inside of satellite carriages and let sit inside the carriage closest to bin wall. See Fig. 25, Detail 1.

49.1 *Note:* Hole-to-hole length of reversing rod should be checked by consulting appropriate drawing and tables on Pages 15-17.

50 Bolt opposite end of reversing rod (without threaded bolt hole) to bottom of reversing rod toggle gear on primary carriage using 8 mm shoulder bolt and 6 mm locking nut. See Fig. 25, Detail 2.

51.1 *Note:* A standard 5/32” hex wrench will fit this metric shoulder bolt.

51 Screw threaded hanger bolt from parts sack into threaded hole on reversing rod end closest to bin wall until bolt holes on threaded hanger bolt and toggle arm align. See Fig. 26.

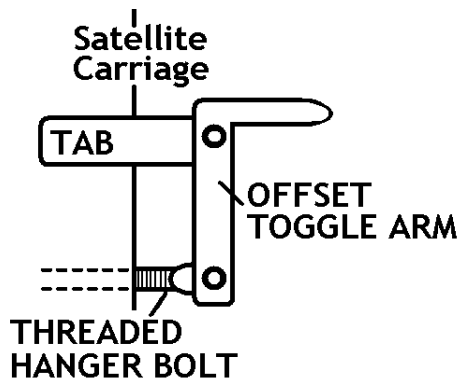

Fig. 26 – Satellite carriage end of reversing mechanism

- 52 Bolt threaded hanger bolt (now screwed into reversing rod) to toggle arm using a 5/16" shoulder bolt and 1/4" lock nut. Ensure reversing mechanism is still in centered position; toggle arm should still be parallel to edge of carriage. See Fig. 26.
- 53 Tighten all 3 shoulder bolts using a 5/32" hex wrench and a 7/16" wrench.
- 54 Ensure reversing mechanism can move freely by shifting it from one locked position to the other.

IX. Wiring Gearmotor on Center Hanger

See Page 21 to identify parts referenced in this section. Also see wiring diagrams on Pages 48-59.

- 55 Locate black 18ga 3-wire cord on primary carriage junction box. Zip-tie cord to cord hanger, providing a drip loop in cord by junction box.
- 56 Run cord along cord hanger and down side of center hanger, securing cord using zip ties.
- 57 Remove cover of gearmotor junction box. Save screws.

- 58 Insert 3/8" electrical connector from hardware sack into hole on bottom of gearmotor junction box.
- 59 Tighten metal fastening ring inside of box.
- 60 Thread 3-wire cord through electrical connector, providing a drip loop in cord by motor. Secure 3-wire cord by lightly tightening connector screws using screwdriver.
 - 60.1 *Note:* At this point, there will be six wires from gearmotor and three wires from three-wire cord inside gearmotor junction box.
- 61 Twist together motor wires T3, T5 and T2. Secure with yellow wire nut.
 - 61.1 *Note:* Sack with yellow wire nuts should come attached to carriage junction box.
 - 61.2 *Note:* In Steps 61-65, ensure wires and wire nuts are connected tightly so they do not vibrate out of place during use of machine.
- 62 Twist together motor wires T1 and T8, along with incoming wire L1. Secure with yellow wire nut.
- 63 Twist together motor wire T4 with incoming wire L2. Secure with yellow wire nut.
- 64 Attach incoming ground wire to green motor grounding bolt in motor power box.
 - 64.1 *Note:* All wires should now be connected.
- 65 Replace cover on gearmotor using saved screws.
 - 65.1 *Note:* Ensure wires are not pinched before tightening cover down.

X. Wiring Motors

See Pages 66-71 to help identify parts referenced in this section.

Note: 460V motors are factory-wired without plug-ins due to their high voltage and will not need to be connected.

Note: Single phase, three-auger units and four- and five-auger units must use dual lead rotating contact.

66 Position rotating contact about where it threads into cast electric junction box, but **do not thread rotating contact into place until machine is raised in bin.** See Pages 27, 28 & 30 for further rotating contact installation instructions.

NOTICE: Failure to heed instruction in Step 66 can result in component damage and failure.

67 Run cord(s) from rotating contact up center hanger and out to end of cord hanger alongside 3-wire cord from primary carriage junction box, leaving drip loop near rotating contact. See Fig. 27.

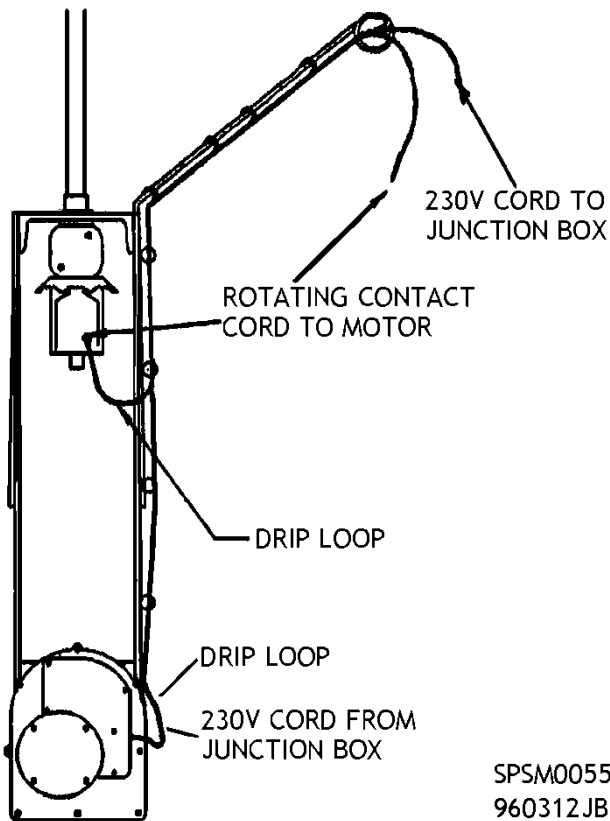

Fig. 27 - Cord placement on center hanger

68 Connect rotating contact cord plug to plug on appropriate cord coming from "A" or "S" motor

on primary carriage. See next page for cord connection diagrams.

- 69 On three-auger, single phase and four- and five-auger units: Connect second rotating contact cord plug to plug on cord from appropriate satellite carriage motor. See Fig. 29.
- 70 Secure rotating contact cord(s) to cord hanger and center hanger using provided zip ties.
- 71 Connect plugs on short cord on "A" or "S" motor to short cord on primary junction box. See Fig. 29.
- 72 On multiple-carriage units: Connect motors using plugs on appropriate cords. See Fig. 29.

XI. Wiring Tilt Switches on Motors

See Pages 68-72 to help identify parts referenced in this section.

73. On multiple-carriage units: Connect two black wires with male spades on satellite carriage tilt switches to black and white wires with female spades at one end of provided black tilt-switch cord. See Fig. 28.

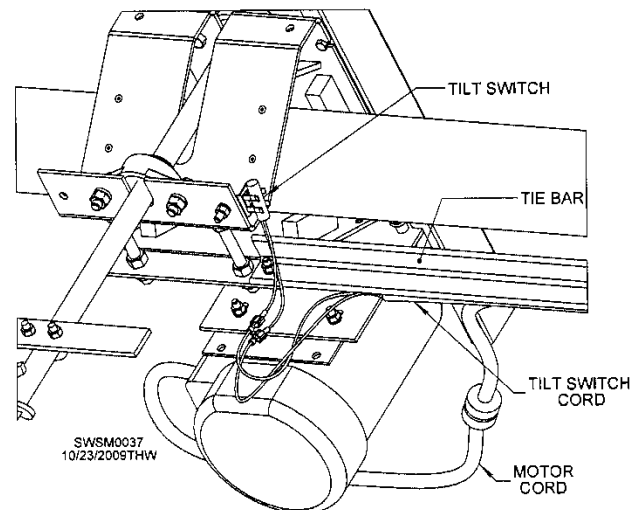
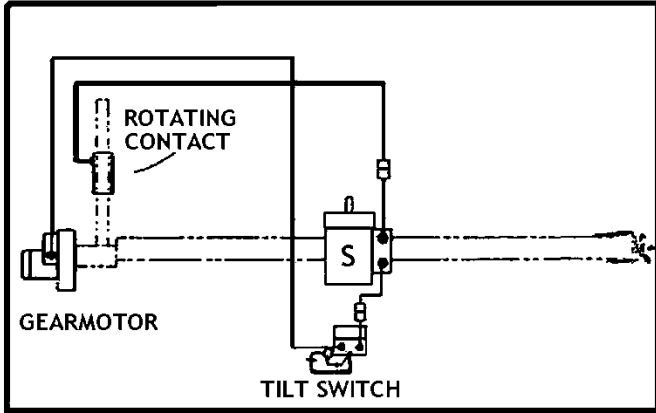

Fig. 28 - Bottom view of satellite carriage tilt switch wiring

- 74 Run black motor cord(s) from Step 72 and black tilt-switch cord through plastic cord holders. See Fig. 11 for plastic cord holder and cord support strap placement.
- 75 Run cords together to primary carriage, securing out of way of moving parts using provided black zip ties. See Fig. 28.
- 75.1 *Note:* Leave enough slack in cords that carriages can travel entire length of crosstube.

Fastir and Fastir Plus Cord Connections



SINGLE AUGER MACHINE

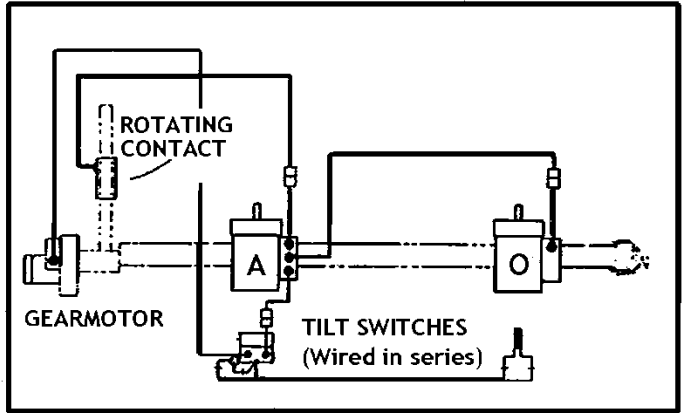

DOUBLE AUGER MACHINE

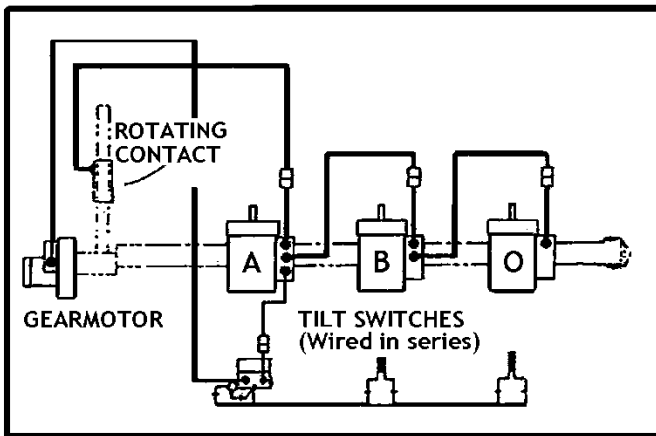

TRIPLE AUGER MACHINE, THREE PHASE

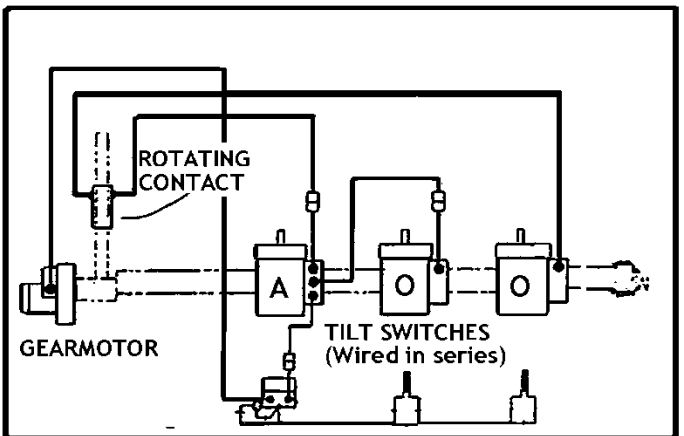

TRIPLE AUGER MACHINE, SINGLE PHASE

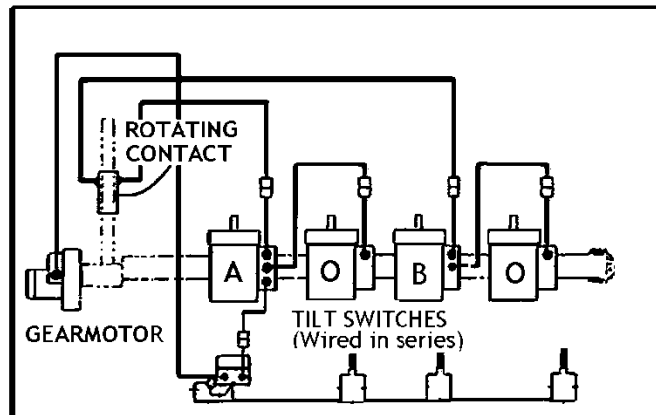

QUADRUPLE AUGER MACHINE

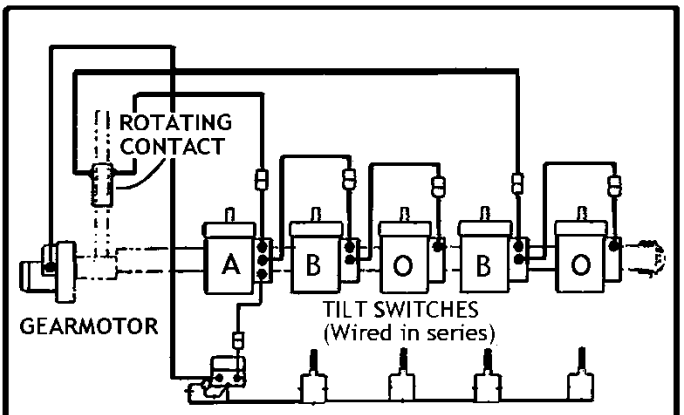

QUINTUPLE AUGER MACHINE

Fig. 29 – Motor & tilt switch cord connection diagrams

Note: Above diagrams are for machines with 230V motors. 460V units are wired directly and have no plugs.

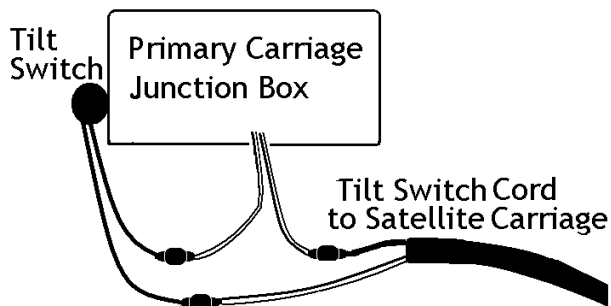

Fig. 30 – Primary carriage junction box & tilt switch wiring

- 76 Connect black wire with male spade from black tilt-switch cord to one white wire with female spade from primary carriage junction box. See Fig. 30.
- 77 Connect white wire with female spade from same end of black tilt-switch cord to one black wire with male spade from primary carriage tilt switch. See Fig. 30.
- 78 Connect female spade on remaining white wire from primary carriage junction box to remaining black wire with male spade from primary carriage tilt switch. See Fig. 30.

XII. Installing Machine

See Pages 61-62 to help identify parts referenced in this section.

- 79 Raise machine to top of bin so that outside drive wheel end rests on track.

WARNING: Keep people away when raising machine with jacks or when working on machine after it is raised. Falling items may cause death or serious injury. Fasten cable to equipment and ensure jacks are securely anchored. Winch should be securely locked before releasing handle. Never permit anyone on or under the equipment being moved or raised.

Cable must be securely fastened to the equipment and to the winch drum. Always ensure cable is pulling straight off the winch and is not in contact with the frame or drum sides. Always prevent cable from rubbing against fixed objects.

Always inspect cable and hook before each use to ensure they are not damaged. Replace cable if it is frayed or kinked. If cable or hook breaks, cable can act like a whip and inflict serious injury to anyone in its path. Never stand alongside cable or guide it by hand. Operate jacks with a firm grip, never with wet or oily hands.

Never leave equipment unattended when hanging by the winch or allow unauthorized persons to operate the winch.

- 80 Securely wire end of crosstube that rests on track to track in order to avoid movement during machine installation.
- 81 Bolt hangers to peak ring support band. See Fig. 31.

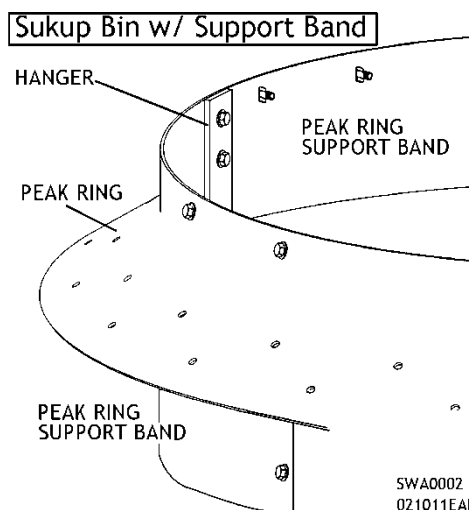

Fig. 31 - Preparing machine for hanging

- 81.5 *Note:* In Sukup bins ordered with Fastir units and in all Sukup bins 40' and larger, a support band is located inside of peak ring. In non-Sukup bins, hangers bolt only to peak ring.
- 82 Bolt chains in hangers using keyhole slots, adjusting chains so crosstube is level. See Fig. 32.

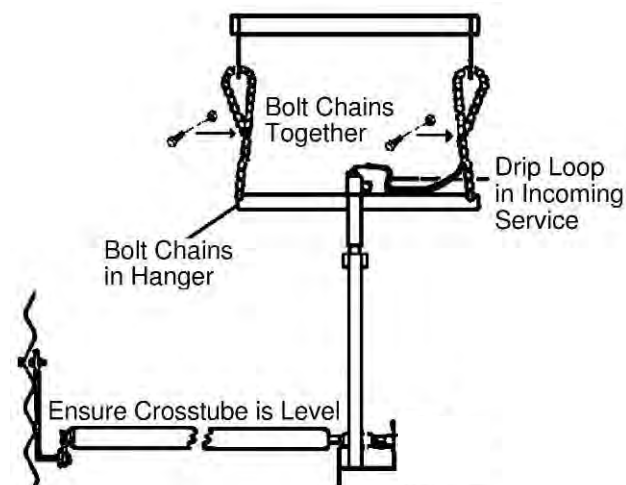

Fig. 32 - Leveling crosstube during installation

- 83 Bolt chains together. See Fig. 32.

XIII. Installing Rotating Contact

See Page 62 to help identify parts referenced in this section.

- 84 After machine is raised in bin, place drip plate over threaded end of rotating contact so plate opens downward. See Fig. 33.

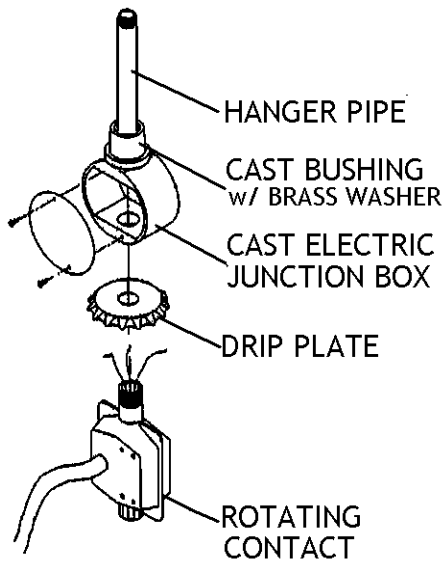

Fig. 33 – Rotating contact installation

- 85 Tightly thread rotating contact into bottom of cast electric junction box on center hanger. See Fig. 33.

XIV. Installing Optional Spreader-Bar Kit

See Page 62 to help identify parts referenced in this section.

On narrow hatch openings, it may be necessary to spread hanger chains to provide clearance for grain spreader fin. The following instructions detail installation of Sukup Manufacturing Co.'s optional spreader bar kit (**Part # A5635**).

- 86 Determine clearance needed and place one bolt in proper hole on spreading bar.

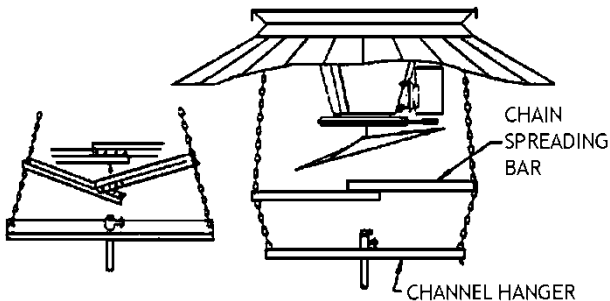

Fig. 34 – Placement & installation of spreader bar

- 87 Place slotted ends of spreading bar on chain as shown and force chains apart by pushing bar straight. See Fig. 34.

87.1 *Note:* Ensure spreading bar is far enough below grain spreading fins to avoid fins hitting bar.

- 88 Place second bolt in matching holes on spreading bar and tighten both bolts.
89 Ensure crosstube remains level after spreading chains; re-level if needed.

XV. Preparing Down Augers

See Pages 66-71 to help identify parts referenced in this section.

Bottom of each down auger must be 3" to 5" above floor or any unloading equipment that could be an obstruction.

DISCLAIMER: Use of down augers longer than 20' will void warranty on stirring machine. Damage to other components as a result of using down augers over 20' will not be the responsibility of Sukup Manufacturing Co.

Sukup Manufacturing Co. makes no warranty, express or implied, with respect to down augers longer than 20', including, without limitation, any warranty of merchantability and warranty of fitness for a particular purpose. The following calculations will help determine down auger cut length.

Down Auger Cut Length

Depending upon bin, two different lengths of down auger may be needed for proper clearance and operation. Use following formulas to calculate required down auger length(s).

Note: Final cut length tolerance is **+ or - 1"**.

CALCULATING DOWN AUGER LENGTH

$$DA = L +(\text{plus}) H - (\text{minus}) \text{Clearance}$$

L: Measure from top of track rail to bin floor.

H: For bins up to 40': **7.5"**
For bins 40' and up: **8.0"**

Clearance: Clearance is distance from bin floor to bottom of auger, taking into account any obstruction such as a sweep. Recommended clearance from any object or floor is 3 to 5 inches.

Note: Outside auger **MAY** need to be shorter to clear sweep drive wheel. See Fig. 35.

Following are dimensions of typical Sukup products to aid in calculating down auger length.

REFERENCE DIMENSIONS OF SUKUP PRODUCTS

Product and Relational Dimensions Needed for Accurate Calculation	Height (Inches)
6" and 8" Sukup power sweeps	10
10" Sukup power sweep	11-1/2
Sukup power sweep w/ 17" drive wheel	17
Height from cement floor to top of metal floor w/ standard 13-1/4" floor supports	13-1/2
Top of bin sheet to top of rail on pre-punched, non-commercial Sukup bins (Use if track is to be installed on existing horizontal bin sheet bolts.)	7-1/2

(Examples of calculations shown on next page)

DOWN AUGER LENGTH EXAMPLES

EX1: An **existing** 30' bin will have a Fastir Triple installed. "L" is measured at 200". There is no sweep, and a 4" clearance between floor and auger will be used.

$$DA = 200 + 7-1/2 - 4$$

$$DA = 203-1/2"$$

EX2: A **new** Sukup 6-ring, 42' farm bin (265" eve height) will have a Fastir Plus Triple installed during bin assembly. An 8" Sukup power sweep will be installed on a floor with 13-1/2" floor supports.

$$L = (265" \text{ eave height}) - (13-1/2" \text{ for floor}) - (7-1/2" \text{ for top of sheet to rail})$$

$$L = 265 - 13-1/2 - 7-1/2$$

$$L = 244"$$

$$DA = (244" \text{ for L}) + (8.0" \text{ for H}) - (10" \text{ for sweep}) - (4" \text{ for clearance})$$

$$DA = 244 + 8.0 - 10 - 4$$

$$DA = 238"$$

Because a Sukup power sweep will be installed, stationary carriage will need a shorter auger.

$$OA = (244" \text{ for L}) + (8.0" \text{ for H}) - (17" \text{ for sweep wheel}) - (4" \text{ for clearance})$$

$$OA = 244 + 8 - 17 - 4$$

$$OA = 231"$$

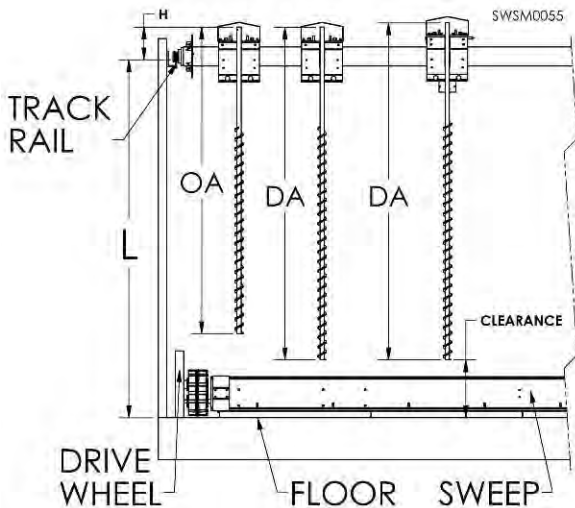

Fig. 35 - Down auger preparation

90 Mark appropriate position on auger for cut.

91 **Weld or braze flighting slightly above point of cut to prevent unraveling.**

92 Cut down augers to length.

92.1 *Note:* Down augers should be cut from bottom prior to installation, but can be trimmed later if sweep is installed.

93 Bolt flinger to auger just above auger flighting using 5/16" x 1-3/4" U-Bolt and 5/16" nuts and tighten using 1/2" wrench. See Fig. 36.

94 Slide listed items over top of each auger shaft in order shown in Fig. 36.

- Flange bearing (hub up)
- Locking collar for bearing (groove down)
- Flange bearing (hub up)
- Locking collar for bearing (groove down)
- 9" pulley (hub up).

94.1 *Note:* If parts will not slide smoothly over shaft, use emery cloth or file to clean shaft.

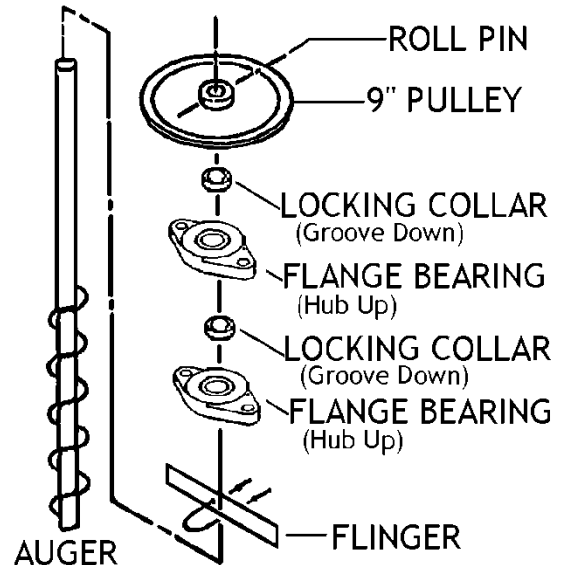

Fig. 36 – Down auger assembly

95 Attach 9" pulley to top of auger shaft by inserting 5/16" rollpin in hole provided on shaft. See Fig. 36.

96 Slide top locking collar and top flange bearing up against pulley.

97 Position a punch in unused hole on locking collar and **lightly tap** with hammer in direction of shaft rotation to lock flange bearing in place.

97.1 *Note:* **Do not overtighten** collar or bearing race will crack.

98 Tighten setscrew on top locking collar using hex wrench.

XVI. Installing Down Augers

See Pages 66-71 to help identify parts referenced in this section.

99 Slide auger up through slot in carriage so top bearing rests on two pre-installed 7/16" x 1-1/2" bolts, which point up through top of carriage plate and are secured with push nuts. See Fig. 37.

100 Add 7/16" lock washers and nuts to pre-installed bolts to bolt top bearing to carriage. Tighten using 11/16" wrench. See Fig. 37.

- 101 Slide bottom bearing down and bolt to carriage with 7/16" x 1-1/4" bolts and 7/16" lock washers and nuts. Tighten using 11/16" & 5/8" wrenches. See Fig. 37.

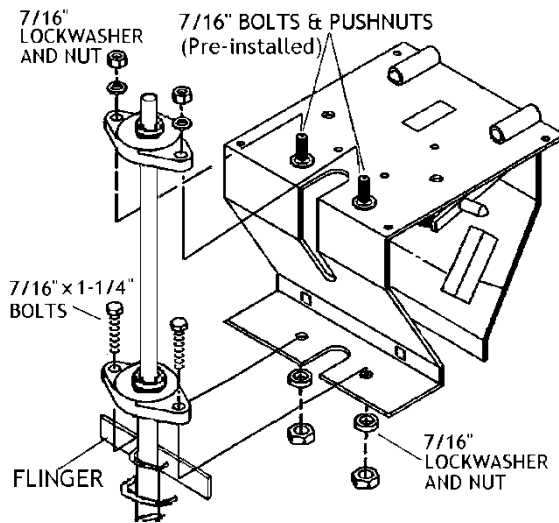

Fig. 37 – Installing down auger on carriage

- 102 Position a punch in unused hole on locking collar and **lightly tap** with hammer in direction of shaft rotation (CW when viewed from above).
 102.1 **Note: Do not overtighten collar** or bearing race will crack.
 103 Tighten setscrew on bottom locking collar using hex wrench.
 104 Ensure there is clearance of about 1/4" between down auger and crosstube.
 105 Ensure there is still clearance of about 1/16" (thickness of credit card) between crosstube and bearing blocks. See Fig. 38.

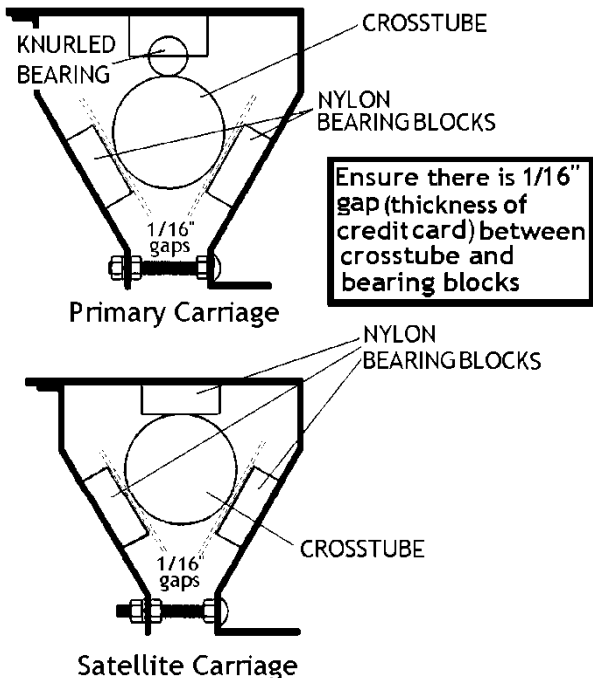

Fig. 38 – Side view of primary & satellite carriages

- 106 Mount belts to 9" pulley on down auger and pulley on motor, aligning if necessary.
 106.1 **Note:** Pulley should touch bearing lock collar.

- 107 Mount center carriage shields to carriages. Holes in shield must be aligned with slots in corners of top carriage plate.
 108 Bolt center carriage shield to carriage using 1/4" x 1" bolts and tighten using 7/16" wrench.
 109 For **Fastir** unit, bolt on cord support strap and tie-strap cord onto bar of primary carriage. For **Fastir Plus** unit, tie-strap cord to bars of primary and outside satellite carriages.
 110 Bolt plastic cord holders (with black cords through them) onto carriage shields using screws provided with cord holders and tie-strap cord to cord support strap.

XVII. Final Steps

See Page 62 to help identify parts referenced in this section.

- 111 Have electrician use liquid-tight elbow and drip loop to bring electrical service into cast electric junction box on center hanger. Wire to leads of rotating contact. See Fig. 39. Also see wiring diagrams on Pages 48-59.

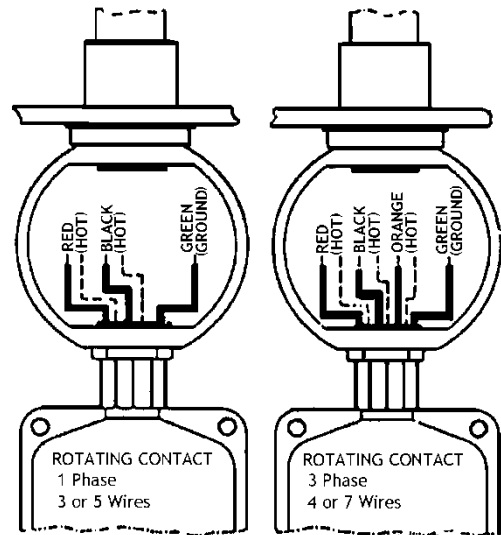

Fig. 39 – Rotating contact wiring

Note: See max amps & breaker table on Page 9.

- 112 Have electrician provide an electrical disconnect/on-off switch at top of bin to ensure machine cannot be turned on accidentally during service and for more convenient operation.
 113 Ensure crosstube is unwired before operation (See Step 80).
 114 Ensure entire length of track and bin sidewall are free from obstructions that could hinder movement of crosstube or outside carriage and auger around bin.

--- INSTALLATION COMPLETE ---

FASTIR OPERATION GUIDELINES

Sukup Fastir machines benefit in-bin drying by:

- **Eliminating overdried grain layers.** Stirring mixes grain throughout bin.
- **Drying faster.** Stirring allows use of higher drying temperatures.
- **Increasing drying capacity.** Stirring loosens grain and allows increased airflow through it.

As the machine mixes and loosens bottom layers of grain that are easily overdried, grain may be heated to higher temperatures to achieve faster drying rates without any of the typical effects of overdrying.

I. Operation Procedures

- 1 Start machine when grain is about 30", or one ring, deep.
 - 1.1 **Note: Do NOT wait to start machine when grain bin is nearly or completely full.**
 - 1.2 **Note: When drying grain, peak lid should be open or ajar to release additional moisture from bin.**
- 2 **Never turn off machine while drying grain or when continued filling will take place.** In natural air drying or low temperature drying, do not shut machine off until grain is dry.
- 3 In situations where a multiple-auger machine is used and drying of one bin of grain will take longer than four weeks, operate stirring machine intermittently to reduce grain damage.
 - 3.1 **Note:** Amount of time machine should be operated depends on many factors, such as ambient air temperature and humidity, size of bin, grain type and cleanliness, and amount of heat added. Contact dealer for more information.
- 4 **Do not overfill bin.** Filling must be stopped when distance between top of grain mound and crosstube reaches 18" to prevent belt and motor failure. **Filling above this point voids equipment warranty.**
- 5 Use probe to determine moisture content of grain. When grain first tests dry on top, grain throughout entire bin may **not** necessarily be dry. Remember: Sukup stirring machine is designed to move dry grain from bottom and bring it to top.
- 6 **After grain has dried, shut off heater. Cool grain and continue stirring.** Ensure grain is thoroughly cooled before shutting off fan. Continue stirring for an additional 48 hours.
 - 6.1 **Note:** Sukup Manufacturing Co. also recommends periodically running stirring machine during winter months if grain is not frozen.

II. Restarting Fastir Machine

Note: Shutting off machine allows grain to "set up" around augers during inactivity. If machine has been idle for more than two days, take following steps when restarting it:

- 1 Support carriages and prevent distortion of crosstube by setting boards on top of grain as shown in Fig. 40.

IMPORTANT: Take all precautions noted on safety decals. See Page 7.

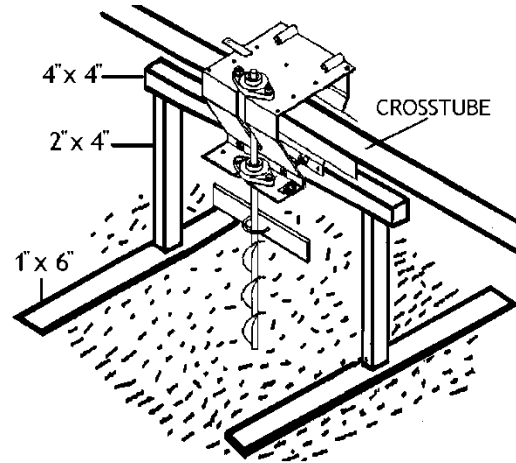

Fig. 40 – Supporting carriage during restart

- 2 Before power is applied, loosen down augers by turning clockwise.
- 3 For 230V Units Only: Unplug all motors and start each individually beginning with motor nearest to center of bin.
- 4 Remove boards below carriages before restarting.

III. Fastir Maintenance

At beginning of each drying season, check that:

- Belts are aligned and in good condition
- Shields are securely in place
- Electrical connections are tight and insulated
- Gearmotor and shear pins are in good condition
- Down augers are not bent, worn out, or otherwise in need of replacement
- Locking collars are tight on bearings
- Electrical cords are secured out of way of all moving parts
- All bolts and nuts are tight
- Hairpin clips are inserted through holes on ends of motor mount rods.
- All safety decals are in place and in good condition. See Page 7.
- If down auger bearings have grease zerks, apply a small amount of grease once a year.

IV. Gearmotor Lubrication

Gearmotor comes prefilled with synthetic gear oil that is intended to be suitable for life of gearmotor. Break-in time on lubrication is 25 hours.

If oil replacement need is suspected, testing can be done to determine oil quality. If results show any of the following, oil replacement is required:

- Viscosity has changed by approximately 10% or more [prefilled with Synthetic oil (Polyglycol) CLP PG 680]
- Debris particles (silicon, dust, dirt or sand) exceed 25 ppm
- Iron content exceeds 150-200 ppm
- Water content is greater than 0.05% (500 ppm)

- Total acid number (TAN) tests indicate a significant level of oxidative break-down of oil.

Recommended oil specifications:

- Mobile Glygoyle 680 (ISO grade VG680, type FG-PG)
- If installed in grain bin where in-bin ambient temperature during operation will not exceed 104°F, Mobile Glygoyle 220 (ISO grade VG220) is acceptable.

Capacities:

- Shaft/main reduction: 3.2 oz / 180 ml
- Intermediate section: 1.0 oz / 30 ml

FASTIR TROUBLESHOOTING GUIDE

WARNING: When servicing equipment, never enter bin unless all power is locked out and another person is present. Always LOCK OUT all power and always check with voltage meter before servicing. Failure to do so could result in death or serious injury.

I. Checking Reversing Mechanism

Note: See Page 23 for instructions for assembling and adjusting reversing mechanism.

- 1 Align toggle gear arms (A & C) and drive bearing (B) so they are parallel with side of carriage plate. See Figs. 41 & 42.

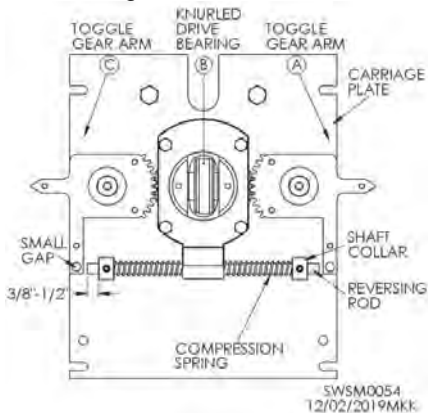

Fig. 41 – Aligned reversing mechanism

- 2 If arms (A & C) and bearing (B) are not in line:

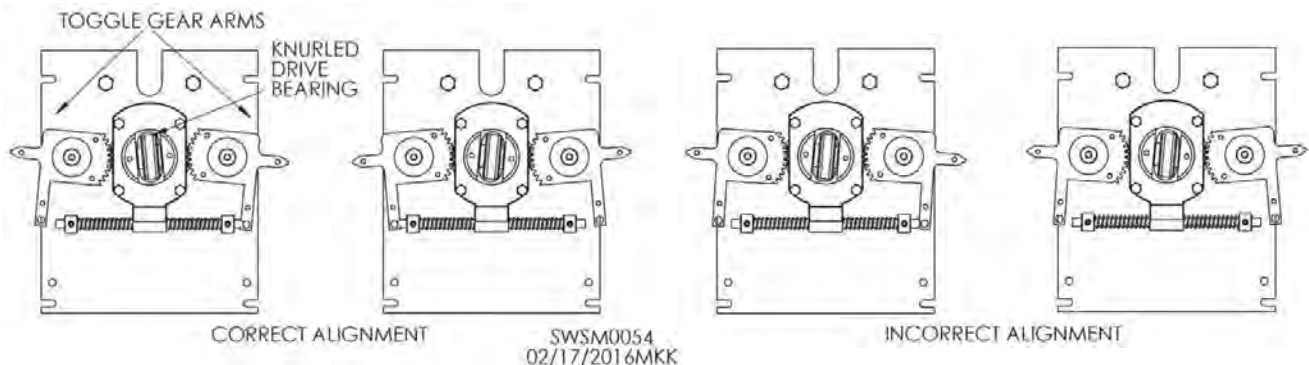

Fig. 42 – Alignment of reversing mechanism

- 2.1 Loosen two large carriage bolts on carriage housing.
 - 2.2 Remove housing.
 - 2.3 Remove drive bearing and directional gear assembly.
 - 2.4 Reinstall directional gear between toggle gears so that drive bearing (B), and both toggle gear arms (A & C) are parallel to carriage plate.
 - 2.4.1 *Note:* Ensure thrust bearing in directional gear is in place.
 - 2.4.2 *Note:* Torque toggle gear bolt to 30 ft.-lbs.
 - 2.5 Put carriage housing back on and retighten bolts.
- 3 Compression spring should have same measurement on both sides of carriage housing to shaft collar. Ensure distance between shaft collar and end of reversing rod is same on both ends. Distance between reversing rod and arm on toggle gears should also be checked for distance. See Fig. 41.
 - 4 Reversing mechanism assembly is aligned **correctly** when angle of knurled center bearing is opposite angle of the two toggle gear arms. See Fig. 42.

See Table 10 for common problems and solutions.

Problem	Reason	Solution
Gearmotor not turning while augers are vertical.	No electricity	Check plug-in for proper voltage using voltmeter.
	Automatic thermal overload shut off. 230V to 115V gearmotor or 115V to 230V gearmotor.	Check plug-in for proper voltage Check for binding or obstruction on track or tube.
	Gears may be out of gearmotor.	Feel if gearmotor is running. If so, speed reducer must be replaced. Part # is J3671G.
	Capacitor bad.	Replace capacitor.
	Tilt switch(es) on augers shutting off gearmotor on center hanger.	Hold down bypass button on junction box. If gearmotor turns, tilt switch is improperly adjusted or faulty. Also check wiring connection.
1-1/2 HP motor not turning.	Thermal overload shut off.	Press reset button. Motor may be running on 115V and must be on 230V (except on 460V units).
1-1/2 HP motor running slow, lacking power.	Wired for 115V or one fuse blown.	Use voltmeter to determine voltage (must be 230V).
Crosstube not turning.	Shearpin sheared on gearmotor.	Replace shearpin.
Crosstube not moving forward on track.	Shearpin sheared on gearmotor.	Replace shearpin.
Machine vibration.	Bent down auger.	Straighten or install new down auger.
Belts breaking.	Belt not properly aligned.	Adjust motor pulley.
	Damaged pulley.	Check pulley and auger shaft for damage and replace if necessary.
Down auger trailing excessively.	Flighting worn off of down auger.	Replace auger.
Machine hitting top of bin.	Track installed too high.	Lower track.
Down auger getting ahead.	Crosstube not traveling around bin. Hard spot or concentrations of fines in center of bin.	Check gearmotor and gears to insure proper function. Replace any damaged part.
Cannot get drying air hot enough.	LP gas vaporizes too slowly.	Provide vaporizer on burner.
Carriage not traveling in or out of crosstube.	Reversing mechanism bearing did not switch completely.	Adjust springs on reversing rod making each side equal. Check detent & spring. Check toggle gear bolt for over-torque. Torque should be approx.30 ft.-lbs.

Table 10 – Common Fastir problems & solutions

PRINCIPLES OF GRAIN DRYING

Note: Information that follows includes general guidelines. Seek more specific information from your local extension office or contact Midwest Plan Service, 4306D Ellings Hall, Iowa State University, Ames, Iowa 50011. Email: mwps@iastate.edu

I. Basic Principles

- Air removes water from grain.
- The more airflow through grain, the faster drying occurs.
- The warmer the airflow through grain, the more water can be removed and the faster drying occurs.
- For every 20°F (11°C) increase in drying temperature, relative humidity (RH) is cut by about half.
- The warmer the air, the drier the grain.

Table 11 illustrates these principles:

Outside Air	Air Temp Heated to	Relative Humidity	Dries Grain to	Drying Ratio
70°F (21°C), 60% RH	No heating	60%	13%	1.0
	90°F (32°C)	31%	8%	2.6
	110°F (43°C)	17%	5%	4.3

Table 11 – Effects of heating grain

As Table 11 shows, simply increasing air temperatures by 20°F (11°C) - from 70°F (21°C) to 90°F (32°C) - cuts relative humidity by half and generates a drying speed 2.6 times faster than original rate. Raising drying temperature by 40°F (22°C) - from 70°F (21°C) to 110°F (43°C) - results in a drying speed that is 4.3 times faster than were no heat added. However, drying grain to 8% or 5% moisture content is very costly and also results in excessive grain damage as bottom layers of grain are over-dried. By incorporating a stirring machine to mix dry grain at bottom of bin with wet, upper grain, desirable average moisture may be obtained. University tests have found that a properly stirred bin will have less than 1% variation in moisture content from top to bottom.

Dry air carries moisture away from grain. Higher airflow rates increase drying rates. Fan speed, motor size and resistance of grain to air determine airflow. Deeper grain depths and higher airflow rates cause higher static pressure against fan. Higher static pressure decreases fan output. Short, wide bins allow grain to dry better than tall, thin bins since there is less grain restriction (static pressure). Tall, thin bins may require 30 times more horsepower than short, wide bins to maintain same airflow. See Fig. 43.

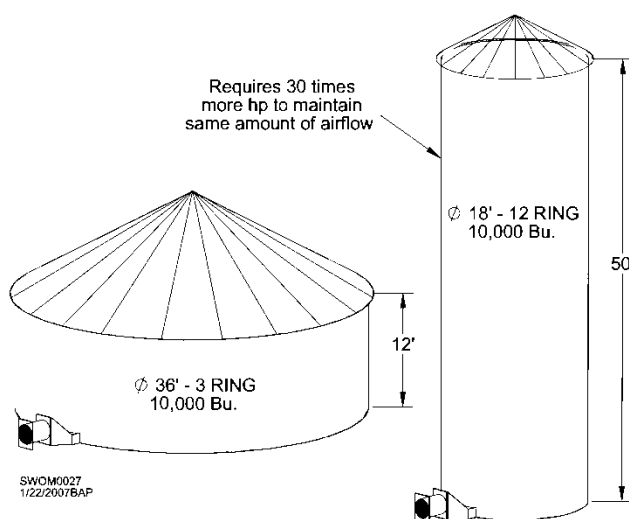

Fig. 43 – Requirements for drying in different-sized bins

As air enters grain it picks up moisture, which cools the air slightly. As air moves through a deep grain mass, the air temperature is gradually lowered and its relative humidity is increased until the air approaches equilibrium with grain. If air reaches equilibrium with grain, it passes through remaining grain without any additional drying. If high relative humidity air enters dry grain mass, moisture is removed from air and enters grain. This slightly dried air will begin to pick up moisture when it reaches wetter grain.

Overdrying

Overdrying grain costs money in two ways: (1) An excessive amount of energy is used to dry the grain. (2) Grain is worth less because of shrinkage.

Table 12 shows extra costs associated with marketing overdried corn. Stirring machines are an excellent way to eliminate overdrying and are essential when a heater is used with a drying bin.

Moisture Content (%)	Extra Drying Costs		Extra Shrinkage Costs		Total Overdrying Costs	
	Dollars (\$)	Euros (€)	Dollars (\$)	Euros (€)	Dollars (\$)	Euros (€)
14	0.035	0.031	0.044	0.040	0.079	0.071
13	0.061	0.055	0.072	0.065	0.133	0.120
12	0.087	0.078	0.099	0.089	0.186	0.167
11	0.117	0.105	0.126	0.113	0.243	0.218

Table 12 – Costs of marketing overdried corn (moisture under 15%)

Costs based on \$.06 per kW/hr (€.046 per kW/hr) & \$1.00/gal LP (€.266/L LP), w/ exchange rate of \$1.00=€1.30

Grain Cooling

Grain dried with a heater must be cooled. Run fans without heat until air coming out of bin is same temperature as that going in, usually a couple of days. Insufficient cooling of grain will result in moisture condensation and grain spoilage during storage.

Fans

Axial fans are the most common types of fan used for aeration. They require a relatively low initial investment and operate well at static pressures below 3 to 4 inches (76 to 100 mm or 750 pa) water gauge. However, axial fans are noisy, and should be directed away from residences if possible.

Centrifugal fans deliver a fairly consistent airflow over a wide range of static pressures, but require a higher initial investment than axial fans. Centrifugal fans are much quieter and more efficient. When aeration is required for tall bins or small grains that create high static pressures, 3,500-rpm centrifugal fans are recommended.

Use Aeration & Drying Assistant in Sukup Office to ensure optimal fan is selected for the application. If using brochures, select a fan according to the manufacturer's rating tables to deliver required air volume at expected static pressure.

Airflow Requirements

Use Table 13 to help determine airflow needed in specified aeration applications. Requirements are presented in standard and metric units.

Aeration Application	CFM/Bu	m ³ /hr/MT
Normal Storage	1/20 to 1/5 (usually 1/10)	4 to 15 (usually 8)
Cooling Hot Grain from Dryer *	1/2	38
Cooling in Bin	1/2 to 1 (usually 1/2)	38 to 76
Wet Holding Tank	1/4 to 1/2	19 to 38
Roof Dryer	12 to 22	911 to 1670
In-Bin Drying: Natural Air	1 to 3	76 to 228
Low Temp (2°F to 5°F temp rise)	1 to 3	76 to 228
High Temp (120°F max for corn)	1-1/2 to 5	114 to 380

Table 13 – Airflow requirements

* If basing airflow on dryer capacity, CFM = 12 x bu/hr capacity of dryer.

Heater Selection

Major factors in heater selection are temperature rise required, type of fuel, heater placement and heater controls. Temperature rise is the difference between ambient (surrounding air) temperature and plenum temperature. Use one of the following formulas to determine heater required:

LP & Natural Gas

$$\text{BTU/Hr.} = \text{Temp. Rise (}^{\circ}\text{F)} \times \text{CFM} \times 1.08$$

$$\text{kW} = \text{Temp. Rise (}^{\circ}\text{C)} \times \text{Cubic meters/hr.} \times .000333$$

$$\text{Temp. Rise (}^{\circ}\text{F)} = \frac{\text{BTU/hr.} \times .93}{\text{CFM}}$$

$$\text{Temp. Rise (}^{\circ}\text{C)} = \frac{\text{kW} \times 3000}{\text{Cubic meters/hr.}}$$

Electric

$$\text{Temp. Rise (}^{\circ}\text{F)} = \frac{\text{kW} \times 3000}{\text{CFM}}$$

$$\text{Temp. Rise (}^{\circ}\text{C)} = \frac{\text{kW} \times 3000}{\text{Cubic meters/hr.}}$$

Very little temperature rise is desired when drying **rice** or **soybeans**, whereas **corn** is often dried with higher temperatures. **Important:** To maintain quality and avoid risk of fire when drying **corn**, in-bin-drying temperature should not exceed 120°F (49°C) for stir drying and 160°F (71°C) for in-bin continuous-flow drying. See Table 14 for maximum air (plenum) temperatures for in-bin drying. Also see Table 16.

Grain	Maximum Air (Plenum) Temperatures			
	In-Bin Drying		Seed	
Barley	110°F	43°C	110°F	43°C
Corn	120°F	49°C	110°F	43°C
Flaxseed	120°F	49°C	110°F	43°C
Mustard	110°F	43°C	110°F	43°C
Oats	120°F	49°C	110°F	43°C
Pinto Beans	90°F	32°C	90°F	32°C
Rye	120°F	49°C	110°F	43°C
Soybeans	110°F	43°C	110°F	43°C
Wheat	120°F	49°C	110°F	43°C

Table 14 – Maximum plenum air temperatures for drying selected grains*

*From North Dakota State University (NDSU) extension service, AE 701 (Revised), November 1994.

Note: These are **general guidelines only**. Drying temperatures may need to be lower for your specific situation. Please contact your local extension office for further information.

Heater Controls

Heater efficiency and cost of operation can be improved through proper selection of controls. For continuous flow drying, use high-low or modulating valve control. When two or more fans are used on a bin, use a high-low or thermostat control, which can be controlled through a dual burner control. The following section describes types of heater controls:

Thermostat – A thermostat cycles heater on and off to maintain plenum temperature. It is the least expensive control, but also least efficient. When burner is shut off, fan is blowing outside air into plenum, cooling it off. On-and-off action provides an average plenum temperature based on setting by user, but there is more short-term temperature variability.

High-Low Burner - The high-low control cycles burner from a high setting to a 20°F to 30°F (10°C to 15°C) lower setting to maintain a more uniform plenum temperature. This eliminates extremes in plenum temperatures from a standard thermostat and provides economy of operation. *Note:* Use High-Low Control with a dual burner control when more than one fan and heater is used on bin.

Modulating Valve - The modulating valve provides the most precise temperature control by continuously regulating burner flame to maintain a constant temperature. Modulating valve relies on a capillary tube filled with gas that expands and contracts with changes in plenum temperature. This gas moves a diaphragm controlling LP gas or natural gas pressure to burner.

Humidistat - The humidistat is used with a low-temperature burner and is located in plenum of bin. It cycles burner on and off based on relative humidity to control humidity of drying air.

Fan, Heater and Controller Locations

Proper fan and heater placement is critical so that airflow and heat are evenly distributed under bin floor. By placing a heater downstream between fan and transition, air moves through fan and is heated. Because air expands as it is heated, additional drying capacity is obtained.

Controls must be located between the primary and one of the secondary fan and heater units. When utilizing two or three fan and heater combinations on same bin, a dual or triple burner control must be used. When two or more fans are placed on a bin, use a high-low or thermostat control, which can be controlled through a dual or triple burner control (modulating valve-controlled heaters may **not** be used in any dual or triple applications). Additionally, plenum temperature should be monitored on outboard sides of any dual or triple fan and heater combinations. Sukup Manufacturing Co. suggests that plenum temperature always be monitored all the way around a bin. Checking bin sidewall with a bare hand in plenum area allows easy detection of hot or cold spots.

Illustration below shows appropriate locations for single, dual and triple fan and heater units and their controls.

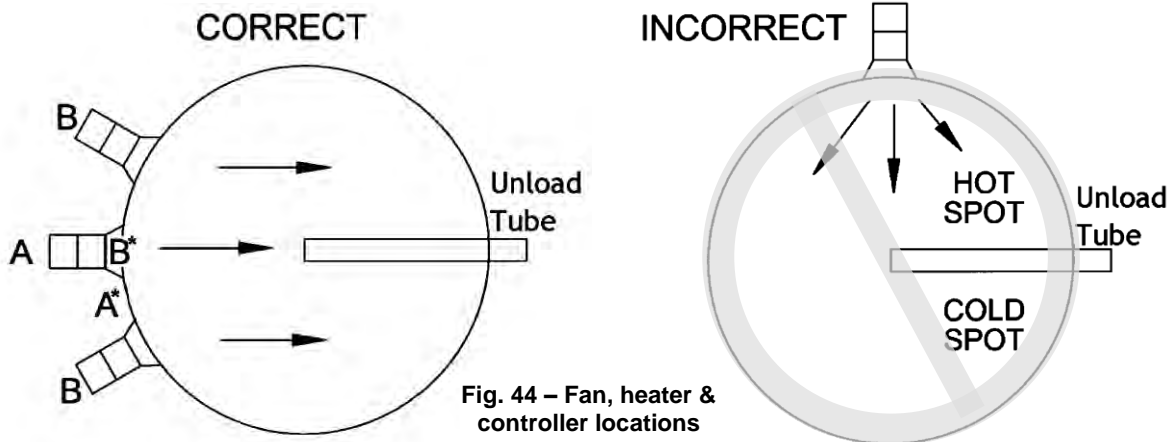

Fig. 44 – Fan, heater & controller locations

SWOM0029
1/31/2007BAP

- | | | |
|-----------|---|--|
| A | — | Single and Triple Fan/Heater Location |
| A* | — | Single and Triple Burner Control Location |
| B | — | Dual and Triple Fan/Heater Location |
| B* | — | Dual Burner Control Location |

Note: When triple fans and heaters are used, “A” becomes primary unit. On dual fan and heater units, either unit may be primary.

Air-straightener vanes must be included in axial fan or heater to provide proper burner operation and even heat distribution in bin plenum. Centrifugal fans may be equipped with either upstream or downstream heaters. Either location may be used with low-temperature heaters. For high-temperature operation, downstream heaters are preferred to provide greater drying capacity. Sukup downstream heaters are equipped with adjustable air-deflecting devices so that heat distribution in plenum can be altered if necessary.

Type of Fuel

Use of propane or natural gas is based on availability. Burners for both fuels can be sized to provide required heat. When using propane as a fuel, either liquid or vapor may be used. Generally, a heater must include a vaporizer for liquid propane when ambient temperature is below 32°F (0°C), and 1 million Btu/hr (292 kW) is required. See Sukup heater manual for sizes of propane tanks required when using vapor propane.

If natural gas is preferred, contact gas company to determine whether adequate line pressure is available for operation. Some companies may be unable to provide a sufficient natural gas supply. For high-temperature heaters, 15 psi (100 Kpa) supply pressure while operating is required to reach maximum Btu/hr (kW/hr) capacity from heater. If natural gas company cannot supply this, a heater with larger piping (e.g., 1-1/4” or 31.75 mm) should be used. Electric heaters provide 1°F to 4°F (1°C to 2°C) of temperature rise. LP and natural gas burners usually have lower operating costs than electrical heaters.

II. Drying Guidelines to Prevent Spoilage along Bin Wall

A large amount of moisture is removed from grain during drying. About 1 gallon of water (3.785 liters) can be removed from one bushel (.029 metric ton) of corn at 25% moisture.

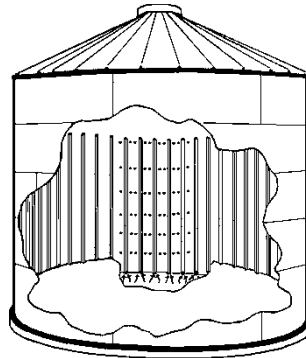
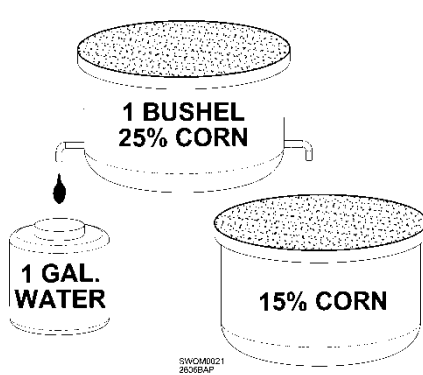

Fig. 45 – Sukup Airway tubes in bin

With so much moisture present, drying hot grain in bins can cause sidewall condensation. Some of this water condenses on bin wall and causes spoiled grain, especially when high drying temperatures - 100°F (38°C) to 120°F (49°C) - are used while outside temperatures are low. For example, when outside temperatures drop below freezing, ice up to 1/2" thick can form on bin sidewalls. When sun shines

on south side of bin, ice located there melts, but remains on shaded portions of wall. If bin is filled at this time, ice on shaded sides is covered up and remains in bin if grain is believed to be dry and operation of fan and heater is discontinued. When temperature rises, ice will melt and soak into grain, resulting in caking and spoilage of grain. Hard spots in the bin, sour-smelling grain when bin's top hatch is opened, and leakage around middle bin sheets all may indicate this type of problem.

Follow guidelines below to prevent grain spoilage caused by moisture condensation that results from drying. This problem is most severe when drying at higher temperatures in colder climates.

- **-Use bin floors** with perforated flashing to ensure maximum airflow along bin wall.
- **-Fans** should provide a minimum of 1.75 CFM/bu (117 m³/hr./MT) aeration rate when bin is full. Listed below are minimum fan recommendations based on 16' (5M) grain depth and 1.75 CFM/bu (117 m³/hr./MT) aeration rate.

Bin Dia.	Type of Cent. Fan	Fan Qty.	Type of Axial Fan	Fan Qty.
24'	10 hp	1	28" 10-15 hp	1
27'	15 hp	1	"	1
30'	20 hp	1	"	2
33'	10 hp	2	"	2
36'	10 hp	2	"	2
42'	15 hp	2	"	2
48'	20 hp	2	"	3

Table 15 – Minimum fan recommendations based on 16' (5m) grain depth & 1.75 CFM/bu (117 m³/hr/MT)

- **Install Sukup Airway tubes**, which pipe air from bin plenum to areas along bin wall where it is needed most, working like a defrosting system on a vehicle's windshield. Sukup Airways consist of a system of 10' or 12' triangular, perforated tubes attached every 9" along inside of bin sidewall. Required number of tubes is four times diameter of bin. The main purpose of Airway tubes is to remove moisture condensation and reduce spoilage costs. Tubes work by directing a metered amount of warm air along bin sidewalls. Ensure tubes are not plugged with fines or bees wings and that flashing is punched so tubes extend through flashing to allow maximum airflow. Fig. 45 shows Airway tubes in bin.
- **Completely empty bin before filling with final batch of grain.**
- **Dry grain at no more than 100°F (38°C) on final batch.** In cooling process (after grain is dried) run fan with heater for one (1) day at 50°F (10°C) to cool grain (air should not steam eyeglasses when checked), then run fans with no heat for two (2) days before shutting down system.
- **Run fans and stirring machines with no heat for 24 hours each month** while grain is in storage and only on days in which humidity is 50% or less.

III. Drying Precautions



WARNING: Read and follow all safety information below. Failure to do so could cause bin fire resulting in death or serious injury.

To Prevent an In-Bin Fire:

- Maximum plenum temperature for in-bin drying without stirring should be no more than 10°F (5°C) above ambient (outside) air. This will help prevent a fire as well as maintain grain quality. See Table 14.

Drying Method	Maximum Plenum Temperature for Drying Corn	
	°F	°C
In-bin Drying without Stirring Machine	10 above outside air temp.	5 above outside air temp.
In-bin Drying with Stirring Machine	120	50
In-bin Continuous Flow Drying	160	70

Table 16 – Maximum plenum temperatures for drying corn

Note: Temperatures are only recommendations. Drying temperatures for other grains vary due to ambient temperature, moisture content and rate of drying. See Table 14, which shows maximum plenum temperatures for drying other grains and seeds. Consult local extension office for information regarding your specific situation.

- **DO NOT** combine drying equipment from various companies. Sukup heaters are intended to be used with Sukup fans only. Sukup heaters have a variety of automatic controls to shut them down in case of ignition failure, high temperature limits or airflow failure. Combining equipment from various companies may result in a lack of safety controls needed to cut power. Inspect these items regularly for proper operation.
- Keep area beneath perforated floor clean of all fines and foreign material as they may cause a bin fire. For even heat distribution, floor supports should not block transition.
- Grain should be screened before going into bin to remove fines and debris. Use of a grain spreader will help distribute fines.
- Thoroughly ventilating bins with dryer fan before igniting heater will reduce risk of a fire or explosion from leaking fuel.
- Faulty electrical wiring can also cause fire. Be certain components are wired by a qualified electrician.

If Fire is Suspected:

Follow these basic fire-safety procedures to ensure safety for you, your family and employees:

- Always account for all co-workers, neighboring farmers and first responders.
- Shut off gas at heater and supply tank. Shut off fan. Call fire department.
- Keep fire away from fuel supply tanks and keep them cool by spraying water on them if needed.
- Seal fan inlet and any other openings to smother fire.
- Remove fan and heater from transition. Sandbag transition opening. If possible, flood bottom of bin (plenum) with water to a depth of 4" (100 mm) above perforated floor. This will protect steel floor supports and may extinguish fire, depending upon its location.
- If fire is located higher in bin, a long pipe with small holes may be inserted through bin wall or manhole and into grain to direct water at source of fire. This may help keep fire in a centralized location, but it's nearly impossible to extinguish a fire in a grain bin by simply pouring water on it. These fires can only be extinguished by completely emptying bin.
- Take note of bin surroundings to avoid heat transfer onto neighboring structures.
- **ALL GRAIN MUST BE REMOVED FROM BIN TO REACH POINT OF FIRE.** Do not cut holes in bin to remove grain. Do not enter a bin that is on fire. Grain may bury you.
- Grain may smolder for days. Do not restart fan in hope that fire has gone out unless all grain has been removed from bin.

MANAGING STORED GRAIN

I. Basic Principles

Grain will deteriorate faster as temperature and moisture content increase. Using corn as an example, Table 17 illustrates just how quickly grain can spoil even with proper aeration.

Grain Temp		Corn Moisture						
		18%	20%	22%	24%	26%	28%	30%
°F	°C	Days Before Spoilage						
30	-1	648	321	190	127	94	74	61
35	2	432	214	126	85	62	49	40
40	4	288	142	84	56	41	32	27
45	7	192	95	56	37	27	21	18
50	10	128	63	37	25	18	14	12
55	13	85	42	25	16	12	9	8
60	16	56	28	17	11	8	7	5
65	18	42	21	13	8	6	5	4
70	21	31	16	9	6	5	4	3
75	24	23	12	7	5	4	3	2
80	27	17	9	5	4	3	2	2

Table 17 – Allowable storage times for aerated, shelled corn

Corn is a perishable commodity with a limited shelf life that depends on its moisture content and temperature. “Shelf life” refers to length of time that aerated, good quality shelled corn can be stored before losing 1/2% of dry matter. With this amount of dry matter decomposition, it is assumed that the corn loses some quality, but maintains its market grade. **For each 10°F (5°C) increase in temperature, storage time is cut in about half when held at a given moisture content.**

Grain moisture content changes with relative humidity of surrounding air. Table 18 shows moisture content of corn at various temperatures and relative humidity. Contact your local extension office for information on other grains.

Grain Temp		Relative Humidity								
		10%	20%	30%	40%	50%	60%	70%	80%	90%
°F	°C	Corn Equilibrium Moisture Content (%)								
20	-7	9.4	11.1	12.4	13.6	14.8	16.1	17.6	19.4	22.2
25	-4	8.8	10.5	11.9	13.1	14.3	15.6	17.1	19.0	21.8
30	-1	8.3	10.1	11.4	12.7	13.9	15.2	16.7	18.6	21.1
35	2	7.9	9.6	11.0	12.3	13.5	14.8	16.3	18.2	20.8
40	4	7.4	9.2	10.6	11.9	13.1	14.5	16.0	17.9	20.5
45	7	7.1	8.8	10.2	11.5	12.8	14.1	15.7	17.6	20.5
50	10	6.7	8.5	9.9	11.2	12.5	13.8	15.4	17.3	20.2
55	13	6.3	8.2	9.6	10.9	12.2	13.5	15.1	17.0	20.0
60	16	6.0	7.9	9.3	10.6	11.9	13.3	14.8	16.8	19.7
65	18	5.7	7.6	9.0	10.3	11.6	13.0	14.6	16.5	19.5
70	21	5.4	7.3	8.7	10.0	11.4	12.7	14.3	16.3	19.3
75	24	5.1	7.0	8.5	9.8	11.1	12.5	14.1	16.1	19.1
80	27	4.9	6.7	8.2	9.6	10.9	12.3	13.9	15.9	18.9
85	29	4.6	6.5	8.0	9.3	10.7	12.1	13.7	15.7	18.7
90	32	4.4	6.3	7.7	9.1	10.4	11.9	13.5	15.5	18.5
95	35	4.1	6.0	7.5	8.9	10.2	11.7	13.3	15.3	18.4
100	38	3.9	5.8	7.3	8.7	10.0	11.5	13.1	15.1	18.2

Table 18 – Corn equilibrium moisture content

Under certain conditions (See Table 18), no matter how long fan is operated, grain may not reach desired moisture content that will allow it to be stored without spoilage. Keep in mind that air temperature and relative humidity are not constant. Use daily averages for determining final moisture content.

Table 19 shows recommended aeration when storing grain for short periods in a wet holding tank at various moisture contents. These rates will only hold grain for lengths of time shown in Table 17. If no aeration is provided, grain may deteriorate much faster if small “hot spots” develop, producing heat and moisture that accelerate deterioration. Aeration is intended to prevent hot spots by keeping all grain at same temperature.

Moisture Content (%)				Airflow	
Corn	Soybeans	Wheat	Rice	CFM/Bu	m ³ /hr/MT
14	10-11	12-13	10	1/10-1/8	8-10
15-17	12-13	14-15	11-12	1/7-1/5	11-15
18-20	14-Max	16-17	13-14	1/4-1/2	19-38

Table 19 – Wet-holding bin airflow requirements

II. Grain Storage

More grain is damaged by improper storage than for any other reason. The most common problems are:

- Inadequate observation of grain during storage - not checking grain frequently.
- Improper grain management - not using aeration to control grain temperature.
- Pockets of fines (broken kernels, weed seeds and debris) restricting airflow and providing food for insects and mold.
- Grain deteriorating because it was held too long without adequate aeration prior to drying.
- Improper cooling of grain after drying. Grain must be dry and cool before storing.
- Poor initial grain quality or insufficient drying to safe moisture content.
- Improper or lack of insect control.

Moisture Content of Grain Storage

The length of time grain can be stored without aeration and the moisture content at which it is stored determine whether there will be significant deterioration. Short-term storage generally refers to storage over winter. Long-term storage spans more seasons. Grain with damaged kernels or with significant amounts of foreign material needs to be stored at moisture levels 1 to 2 percentage points lower than clean grain. Contact local elevator or bin dealer for recommended moisture contents and storage times.

Table 20 shows recommended maximum moisture contents for safe grain storage. Values are for good-quality, clean grain and aerated storage. Reduce moisture content 1% for poor quality grain, such as grain damaged by blight, drought, etc.

Grain	Moisture Content (%)
Shelled Corn & Sorghum	
To be sold as #2 grain or equivalent by Spring	15
To be stored up to 1 year	14
To be stored more than 1 year	13
Small Grains (oats, barley, etc.)	13
Soybeans	
To be sold by spring	14
To be stored up to 1 year	12
Sunflowers	
To be stored up to 6 months	10
To be stored up to 1 year	8
Wheat	13
Rice	12-1/2

Table 20 – Maximum moisture content for safe storage

Grain should be dried to moisture content required for storage period intended. If problems with bin and/or grain arise, see Page 45 for recommended actions. Each of these problems can be minimized with good management. **Aeration must be used to control grain temperature and prevent grain loss.** See Aeration section.

For best results in storing dried grain, an accurate moisture test is needed to determine that grain is dry. Also, an aeration system is necessary for controlling grain temperature. Drying fan can be used for cooling if grain is stored in bin in which it is dried. If grain is to be placed into a different bin, it should be equipped with an aeration system to control grain temperature during storage. It is imperative that grain be cooled during storage to control insects and reduce moisture migration. Moisture content of grain for safe storage depends upon the grain and length of time stored.

Short-Term Storage of Wet Grains

Wet corn is defined as having a moisture content of 16% or higher. Temperatures will not remain constant because wet corn releases heat. Resulting higher temperatures can rapidly lead to corn deterioration due to hot spots. Aeration systems are crucial to prevent this temperature rise. Even with aeration, however, allowable storage time for wet corn is limited, as shown in Table 17.

Storage Preparation

Insects are either already in bins before filling takes place or will enter later. Steps below will aid in prevention of insect problems in grain. For more information on insect control, contact local extension office.

- Clean bin thoroughly prior to filling.
- Repair cracks and/or crevices where moisture and insects may enter.
- Avoid filling bin with new crop before removing all of old crop.
- Clean and check aeration system. Foreign material may collect in ducts, creating an insect breeding environment and obstructing airflow.

Grain Condition for Storage

Grain stores best if it is cool, dry and clean. Mold growth depends on temperature and grain moisture content. Grain that contains considerable foreign material or broken kernels will be more susceptible to mold and insects. Such grain should be cleaned to reduce this hazard or be dried to a moisture content level that is 1% to 2% lower than clean grain.

Checking Grain

All stored grain needs to be checked on a regular basis. Check at least bi-weekly during critical fall and spring months when outside air temperatures change rapidly. Check grain at least once a month during winter, but more often if there are problems. Search for small changes that are indicators of potential problems, such as crusting or condensation on bin roof. It may also be necessary to check moisture content of grain with a moisture meter. Check and record temperatures at several points in bin. Any increase in temperature indicates a problem unless outdoor temperatures are warmer than the grain. Testing weight of grain is another way to monitor its quality.

Filling and Coring Bin

Best storage results are obtained when grain is level in bin. Lowering center core of stored grain improves airflow and makes checking grain easier. Leveling can be done with a grain spreader or by withdrawing grain from center after filling.

In most bins, normal grain discharge flow creates a center core that flows directly down to center sump. This creates an inverted cone in surface grain that gradually increases in diameter. As unload continues, grain funnels down center core to center sump.

A bin filled to its peak will not have uniform airflow. Peaked grain is hard to manage and is particularly risky when grain is stored above its safe moisture content. Part of the peak in all bins should be removed by coring. It is important to core bins filled with moist grain, especially if bin does not have a grain spreader that levels the surface and spreads fines and trash. Coring will remove the majority of fines and foreign material because most fines tend to accumulate in center of bin. This is important since fines are more susceptible to spoilage and will restrict airflow. This practice improves airflow through grain, which reduces chance of spoilage and helps aeration fans work more efficiently.

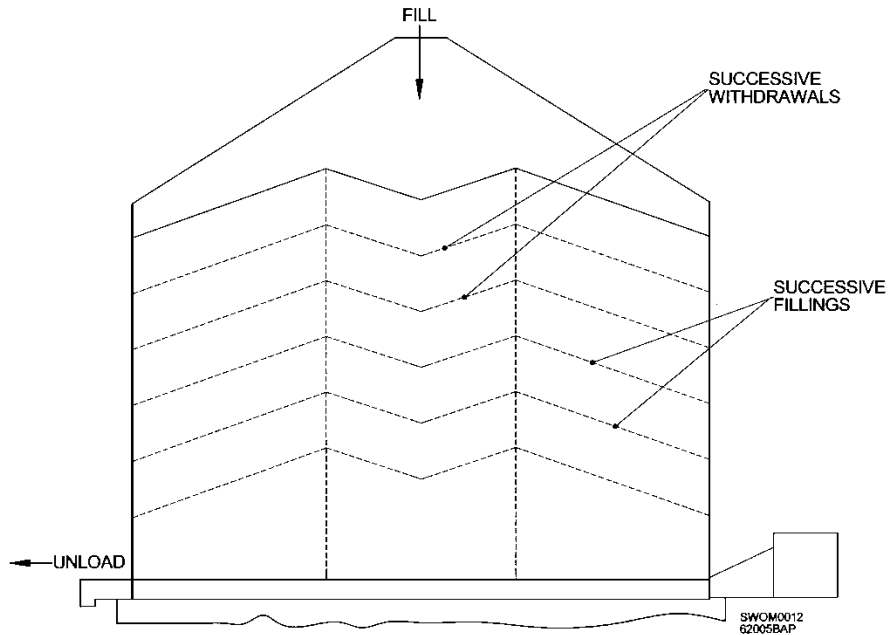

Fig. 46 – Coring bin

Coring is done by unloading grain periodically while bin is being filled. Pull down peak after several feet of new grain is added. See Fig. 46. **Note: Do not fill and core bin simultaneously.** Coring periodically during initial filling will remove a major portion of fines and foreign material. Coring after bin is filled will remove some fines, but not as much as coring periodically when filling.

When coring a bin after filling is complete, remove about half the peak height for improved aeration. After coring, top of grain should be visually inspected to ensure an inverted cone has been created as shown in Fig. 46. If no cone is created, bridging of grain has occurred and a very unsafe condition has been created. Do **not** enter bin until bridging situation has been safely corrected.

Moisture Migration

Crops are normally placed in storage at temperatures much warmer than winter temperatures. Since grains are good insulators, grain in center of bin will be at same temperature as at harvest, even after outside temperatures have dropped well below freezing. This temperature differential causes moisture migration.

Air near bin wall cools and sinks to bottom of bin, pushing air up in center. When grain near surface cools warmer air, moisture in the air condenses. Cool air cannot hold as much moisture as warm air. As this circulation continues, moisture begins to accumulate near top center of bin (as shown in Fig. 47) and crusting may occur, indicating moisture accumulation and mold growth. An aeration system cools grain uniformly, limiting moisture migration. In spring and summer months when outside air warms up, moisture migration may occur in opposite way and moisture will accumulate at bottom of bin.

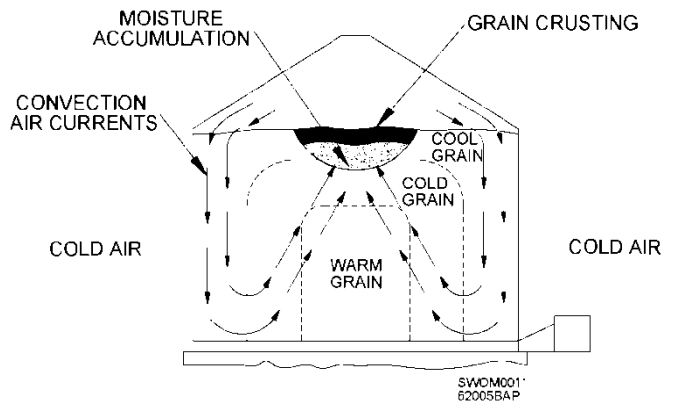

Fig. 47 – In-bin moisture migration

Accessories and Practices for proper grain storage:

Properly Installed Transitions will prevent pressure loss and air loss. Outlet area of transition must be adequate for airflow produced by fan. Transition's shape should provide a smooth airflow without any abrupt direction changes. Transition must be properly sealed at both ends to prevent air loss. If any bin stiffeners need to be cut to install transition, suitable alternative support must be provided to prevent bin wall collapse.

Cleaning grain before storing improves storage. Fines, foreign material and broken kernels can create grain storage problems. Kernels break during harvesting and handling. Select a grain cleaner that collects and conveys screenings away. The most common locations are at receiving, after dryer just before delivery to storage, and at load-out. Cleaning is easier at low flow rates. Coring bin also will remove a major portion of fines and foreign material.

Roof vents ensure proper airflow and prevent snow and rain from entering bin. Roof vents also increase efficiency of aeration system and should always be used in drying. Without adequate open area to let air and moisture out of bin, aeration or drying system will not work sufficiently. There should be a 1ft² (.093 M²) opening for every 1500 CFM (2550 m³/hr.) that fan will produce. Have at least 1" (25.4 mm) eave opening. Keep center cap and manhole open during cooling and drying, but closed during storage. Also, roof vents need to be cleaned of dust and debris after each season to prevent roof damage.

Grain Spreaders are available for bins up to 60' diameter and provide a more level grain surface in bin. Peaked grain produces uneven airflow in bin. Also, fines and foreign material in grain tend to gather in center of bin. These fines contribute to airflow resistance. Properly adjusted and operated grain spreaders will leave top surface of grain closer to level, with fines and foreign material more evenly distributed throughout grain mass. Level surface and more evenly distributed fines result in uniform airflow throughout the bin. See Fig. 48.

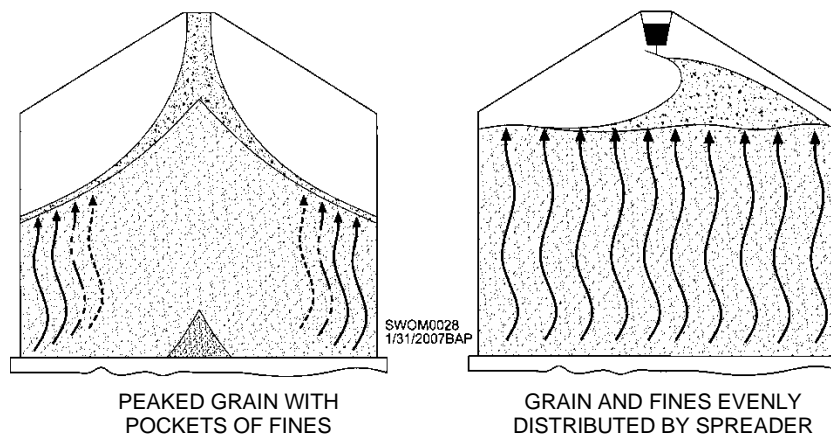

Fig. 48 – Effect of spreaders on peaked grain

III. Aeration

The objective of aeration is to maintain uniform temperature in the grain to prevent hot spots that accelerate spoilage. Ideally a fully perforated floor would be used. However, aeration ducts may be used for structures storing only cool, dry grain.

Since most problems develop in center of bin and grain will cool naturally near wall, aeration system must at least provide good airflow in center of structure. If ducts placed directly on floor of structure are to be held in place by grain, be sure grain is loaded directly on top of duct to prevent movement and damage to ducts. Duct must be strong enough to support grain regardless of its shape or material used. Ensure airflow rate for aeration (storage) is 1/20 to 1/5 CFM/bu, usually 1/10 CFM/bu (4 to 15 m³/hr./MT, usually 8).

Cooling Grain for Winter Storage

Grain should be kept near average outdoor temperature during fall. Increasing airflow rate reduces time needed for cooling or warming, but also increases power requirement. **Begin aeration to reduce grain temperature when average outdoor temperature is about 10°F to 15°F (6°C to 8°C) lower than grain temperature.** The average outdoor temperature is the average daily high/low. You can estimate when a cooling or warming cycle has passed through the grain by measuring the temperature. **Repeat this cycle** as often as necessary, checking temperature at several locations, **until grain has cooled to 35°F to 45°F (2°C to 7C).**

For pressure systems, check temperature at top of grain. For suction, check temperature coming out of fan. **Be sure to continue each aeration cycle until cooling front has moved completely through grain.** This minimizes chances of a moisture front within the grain causing spoilage. If stored grain is very warm or wet, keep fan running through periods of high outside air humidity. Outside air humidity makes little difference when cooling grain since a cooling front moves significantly faster than a wetting front. Table 21 shows length of time required to change grain temperature. To be sure cooling front has passed through grain, check grain and air temperature.

Airflow Rate		Fan Hours by Season		
CFM/Bu	m ³ /hr/MT	Fall	Winter	Spring
1/20	4	300	400	240
1/10	8	150	200	120
1/5	15	75	100	60
1/4	19	60	80	48
1/3	25	45	61	36
1/2	38	30	40	24
3/4	57	20	27	16
1	76	15	20	12
1-1/4	95	12	16	10
1-1/2	114	10	13	8

Table 21 – Approximate grain cooling or warming times

DO NOT FREEZE GRAIN due to problems it can create, particularly during warming and in larger bins. Condensation during aeration can be a problem in grain cooled below freezing. It will be difficult to warm grain in spring without condensation immediately freezing into ice. Frozen chunks block aeration warming cycles and grain unloading. **NOTICE: Condensation also re-wets grain and can cause sudden bin failure and collapse due to expansion of kernels.** If grain does freeze, begin thawing it once the average outdoor temperature is 10° to 15° F (6° to 8°C) above grain temperature. Follow steps outlined in segment below. **NOTICE: Failure to follow instructions for thawing frozen grain may result in sudden bin collapse and failure.**

Managing Grain in Spring and Summer

Start fan when average outdoor temperature is 10° to 15° F (6° to 8° C) above grain temperature. Once warm-up cycle is started, do not turn fan off. Stopping the warming front before a cycle is completed encourages condensation of moisture and spoilage. As outside temperatures continue to rise, repeat this cycle as often as needed until average grain temperature is 50° to 60° F (10° to 16° C). **Maintain grain temp. within 10° - 15° F (5° to 8° C) of the average monthly temp.** Do not warm grain to summer temperatures above 60 F (16 C) in the southern U.S. or 50 F (10 C) in the northern U.S. due to insect infestation and other storage issues.

IV. Addressing Grain Storage Problems

Table 22 shows grain management problems that can arise, and action to be taken.

Observation	Probable Cause	Recommended Action
<ul style="list-style-type: none"> • Musty or spoiled grain odor. • Hard layer or core grain below. • Surface grain wet or slimy. • Grain is sticking or frozen together. • Hard surface crust, caked, and blocking airflow. 	Heating moisture accumulation or moisture migration occurring.	Run fan without heater and turn on stirring machine.

Table 22 – Common grain storage problems & recommended action

V. Bin System Upkeep

Grain bin and equipment maintenance before and during harvest season will help ensure that good quality grain will be stored and preserved. Bin will provide many years of extended service if properly maintained. Use following guidelines as a checklist of maintenance inspections that should be performed on a regular basis.



WARNING: Damage from lack of bin maintenance may cause sudden structural failure and collapse, which may result in death or serious injury. Frequently monitor and inspect bin and foundation for any deflections, cracks or deviations that may occur. Follow operation and maintenance instructions described in this manual.

Roof, Stairs, & Vents

- **Clean debris from bin roof, peak ring, roof vents, and stairs at end of each harvest season.** Dust and debris can cause damage to roof as well as make steps and rungs slippery and unsafe to walk on. Not cleaning debris above roof vents can cause white and brown rust to develop on galvanized metal.
- If an excessive amount of heavy snow accumulates or builds up unevenly on one side of roof, it must be removed immediately.
- **Important:** Inspect bin roof and sidewall for leaks, loose or sheared bolts, and rust or other corrosion. Caulk any cracks, replace and tighten all missing bolts and nuts, and remove rust or corrosion with wire brush and paint over tainted area. If problem is severe, contact Sukup Manufacturing customer service and your dealer.
- Ensure proper function of attachments to all bin openings such as manhole and center caps. Ensure all latches and hold-down clips are used as intended. Also, ensure cap has weather-tight seal and is in correct position if overhead conveyor is mounted. Spouts require roof cap to be permanently fixed.
- Tighten any loose bolts used to attach roof steps to roof ribs and, if necessary, install handrails to increase worker safety. Also, ensure roof ring expanders and splices are in their correct position and properly tightened. Because of workers being at extensive heights, it is important that all roof components be rigid.
- Whenever on the roof, inspect all panels, supporting ribs, stairs, steps, vents, and especially all connections to ensure accidents do not occur. Roof vents should be checked for blockage caused by dirt, dust, debris, frost, ice, bird nests, etc. Clean any debris to allow free airflow and prevent damage to the roof.

Ladders, Catwalks, & Supports

- Ensure access ladders and platforms are intact and securely fastened to bin, and that safety cages are securely attached.
- Catwalks are often supported by steel structures bolted to bin sidewall. Check all connections between the catwalks and the supports often. Bent braces, loose bolts and sidewall damage can be extremely dangerous.
- While climbing ladder, check for any worn-out or loose rungs, loose or missing bolts, and dangerous jagged edges protruding from the ladder or safety cage. Determine cause and fix or replace. Contact Sukup Manufacturing Co. if sheared bolts are discovered, as they may be an indication of a more serious problem.

Sidewall Sheets, Stiffeners, & Doors

- **Inspect bin exterior regularly.** Check for missing bolts, buckled or torn sheets, sidewall bulges, and any unusual changes in bin's appearance. Pay particular attention to bolted joints, noting any waviness along edges, elongated bolt holes, or cracks, all of which are signs of over-stress. If a serious structural problem is detected, contact Sukup Manufacturing Co. customer service and an independent consulting engineer.
- Shim all stiffener base plates if void appears between base plate and concrete. Also, ensure each stiffener base is correctly anchored to foundation. If base plate is not bearing uniformly on concrete foundation, it may cause stiffener buckling somewhere above the base.
- Visually inspect stiffeners and splices to ensure there are no gaps. Improperly connected stiffeners will cause sidewall and stiffener buckling. Ensure base is level on concrete, all bolts and nuts are tight, and stiffeners are supported through an aeration tunnel.
- Ensure door is correctly installed and caulked. Check corrugation around door to ensure a watertight seal. Before filling bin, lock inner doors tight against frame to ensure no structural damage occurs

Foundations

- Inspect bins and foundations for structural problems. Uneven foundation settlement can cause gaps at bottom of bin, resulting in spilled grain, entry points for water, insects and rodents, and exits for forced air, reducing efficiency and increasing costs.
- **Inspect concrete routinely for exposed rebar, unusual cracking, or spalling of concrete.**
- Ensure all anchor bolts are tightened and undamaged. Cracks that develop around anchor bolts result in the bin being susceptible to wind damage.
- Ensure base of bin is uniformly resting on the foundation and sealant is intact. If gaps occur, caulk between bottom of bin and the foundation.

Electrical

- Inspect wiring of fans and other electrical components for corrosion and cracked, frayed, or broken insulation. Exposed wiring should be run through waterproof, dust-tight conduit. Avoid kinks in conduit and ensure all connections are secure.
- Check control boxes for rodent damage. If found, clean and repair or replace broken wiring, relays and other components, and close opening(s) that allowed rodent entry.

Bin Site Maintenance

- Remove any spilled grain from bin site. Mow around bins to reduce likelihood of insect or rodent infestation and ensure water drains away from bin foundations. Items or debris left near bin site may interfere with safe, unobstructed movement around the bin.
- Treat outside of bin at foundation and around door, ducts and fans with insecticide if an insect problem arises.
- Thoroughly clean all bins by removing all old grain. Do not place new grain on top of old. This will help prevent mold and insect infestation of new grain. Remove all traces of old grain from combines, truck beds, grain carts, augers and any other equipment used for harvesting.
- Remove all rust and apply rust-inhibiting primer or paint to affected areas. Removing corrosion in its early stages is better than having rust streaks running down the bin.
- If you find buckled sheets, sidewall bulges or any unusual changes in bin's appearance, please contact Sukup Manufacturing Co. customer service if bin is still under warranty, or an independent consulting engineer to determine problem and find a solution.

Replacement Parts

To replace any deteriorated parts such as bin sheets and flooring, contact your local dealer/distributor. **Do not substitute materials for replacement parts.** Your bin is assembled with certain materials of specific thickness. Do not replace parts without consulting your dealer.

Prior to equipment use, please check that all decals are in place according to this manual and are legible. Safety decals are available for replacement at no charge for Sukup equipment. See Safety Section of this manual. Please specify decal number when requesting replacements.

The grain management information contained in this manual includes general guidelines that come from the sources listed below. Your specific situation may require additional procedures or attention. Seek advice for your specific operation from your local extension office or consulting engineer, or contact Midwest Plan Service, 4306D Ellings, Iowa State University, Ames, Iowa 50011. Email: mwps@iastate.edu

References:

- MWPS-22 Grain Drying, Handling, and Storage Handbook
- ASAE Standard S412.3 Feb '03, St. Joseph, Mich.
- AED-20 Managing Dry Grain in Storage
- Extension Offices at Iowa State University, North Dakota State University, Purdue University, University of Kentucky, University of Missouri

APPENDIX A - WIRING DIAGRAMS

See applicable diagram on this or following pages for wiring of stirring machine carriage motors depending on voltage, phase and number of stirring auger motors. **NOTE:** To reverse gearmotor rotation, switch wires T5 & T8.

NOTE: Down auger carriage motors are transitioning from Leeson to Baldor. See applicable wiring diagram.

230V 1PH LEESON MOTOR

NOTE: Wiring for 1.5hp motor shown. For 2hp motor, lines T2-T3-T8 are replaced by T1-T8 and P2 is replaced by red wire.

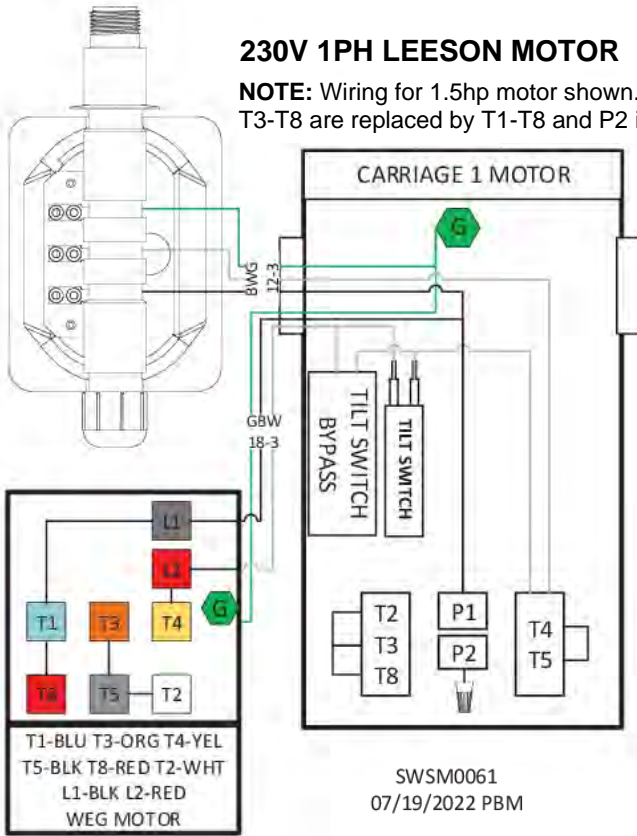

SWSM0061
07/19/2022 PBM

230V 3PH LEESON MOTOR

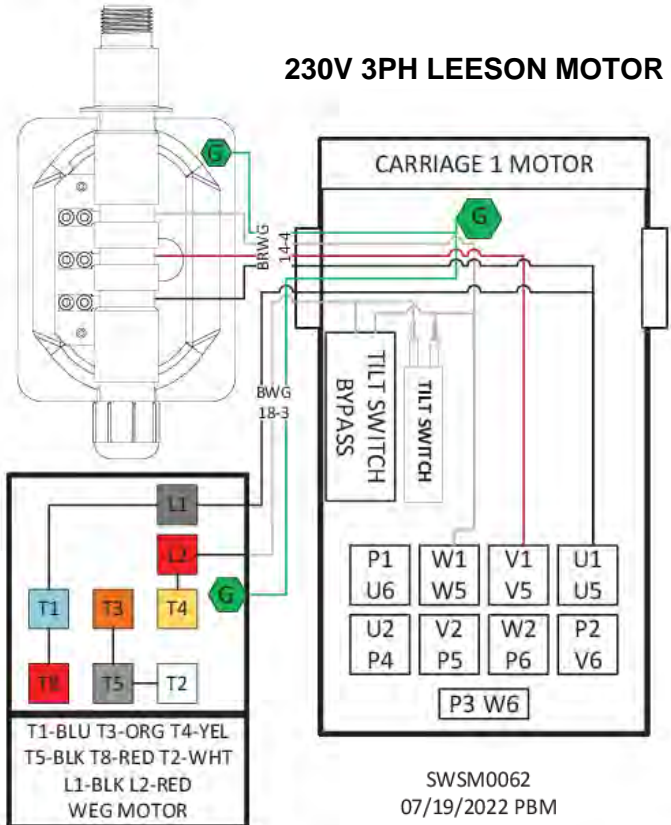

SWSM0062
07/19/2022 PBM

460V 3PH LEESON MOTOR

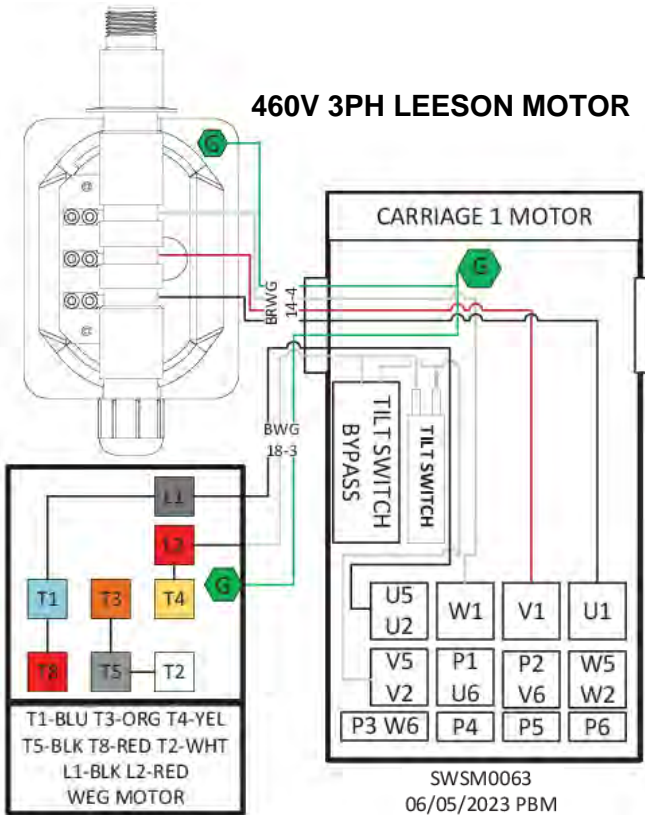

SWSM0063
06/05/2023 PBM

230V 1PH LEESON MOTORS

NOTE: Wiring for 1.5hp motor shown. For 2hp motor, lines T2-T3-T8 are replaced by T1-T8 and P2 is replaced by red wire.

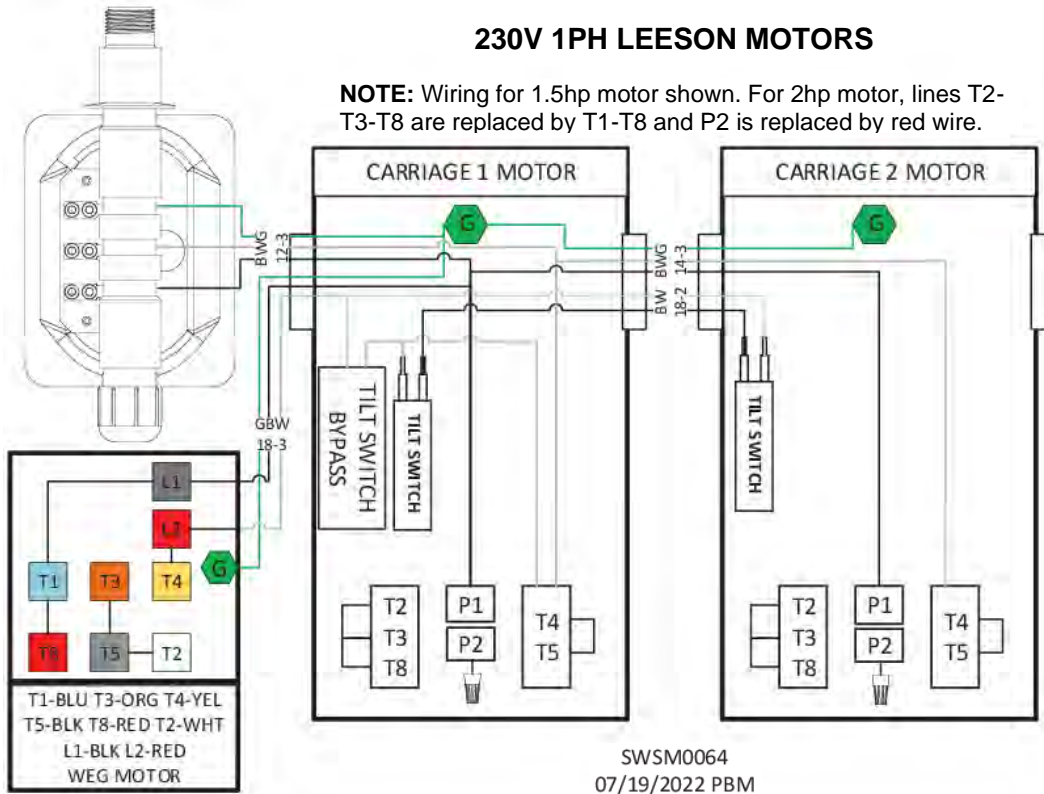

230V 3PH LEESON MOTORS

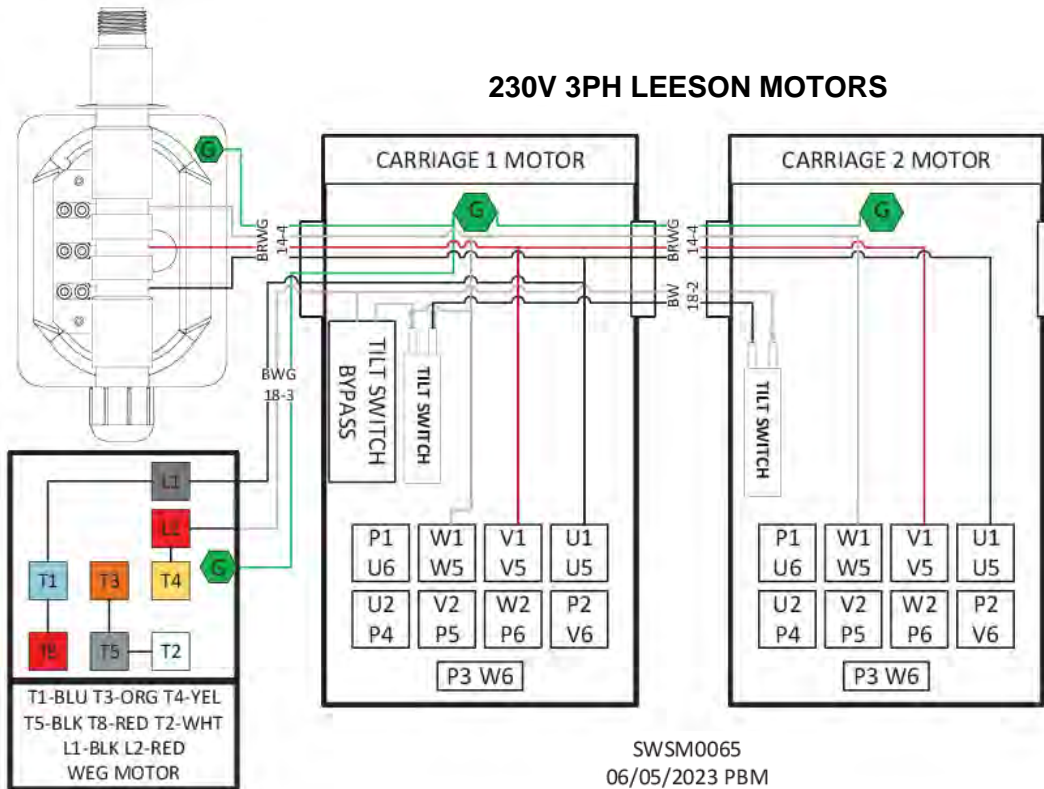

460V 3PH LEESON MOTORS

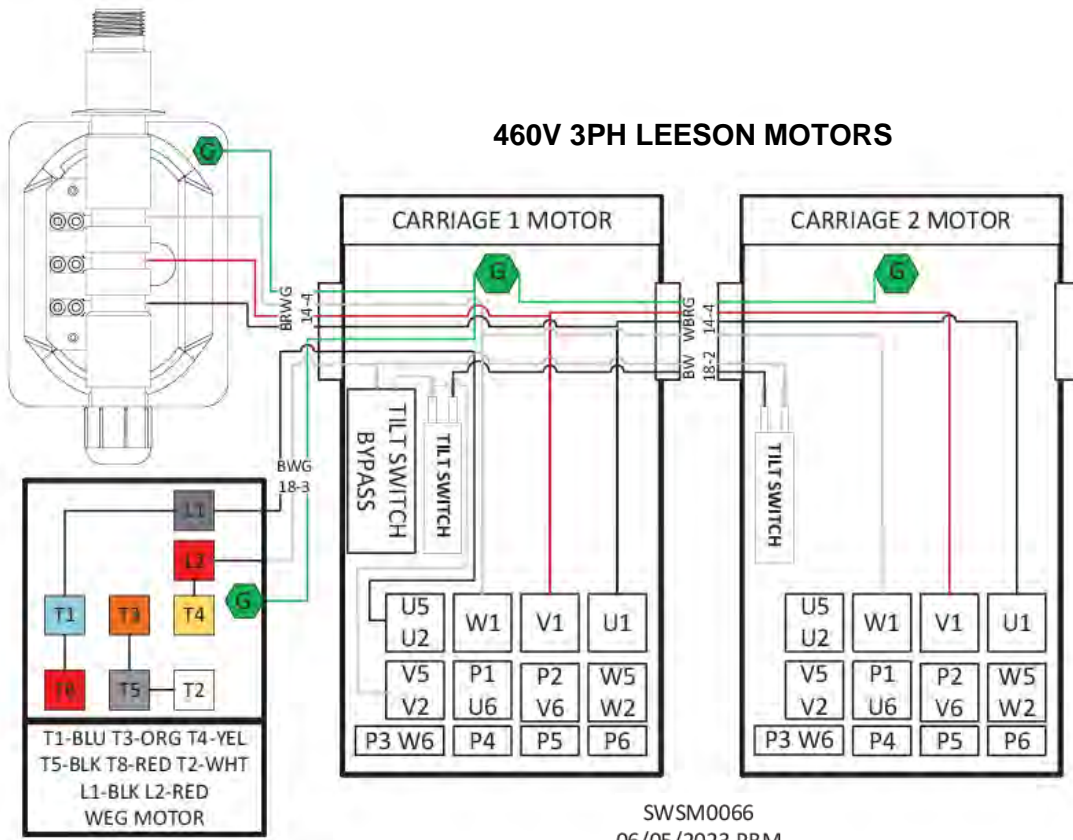

230V 1PH LEESON MOTORS

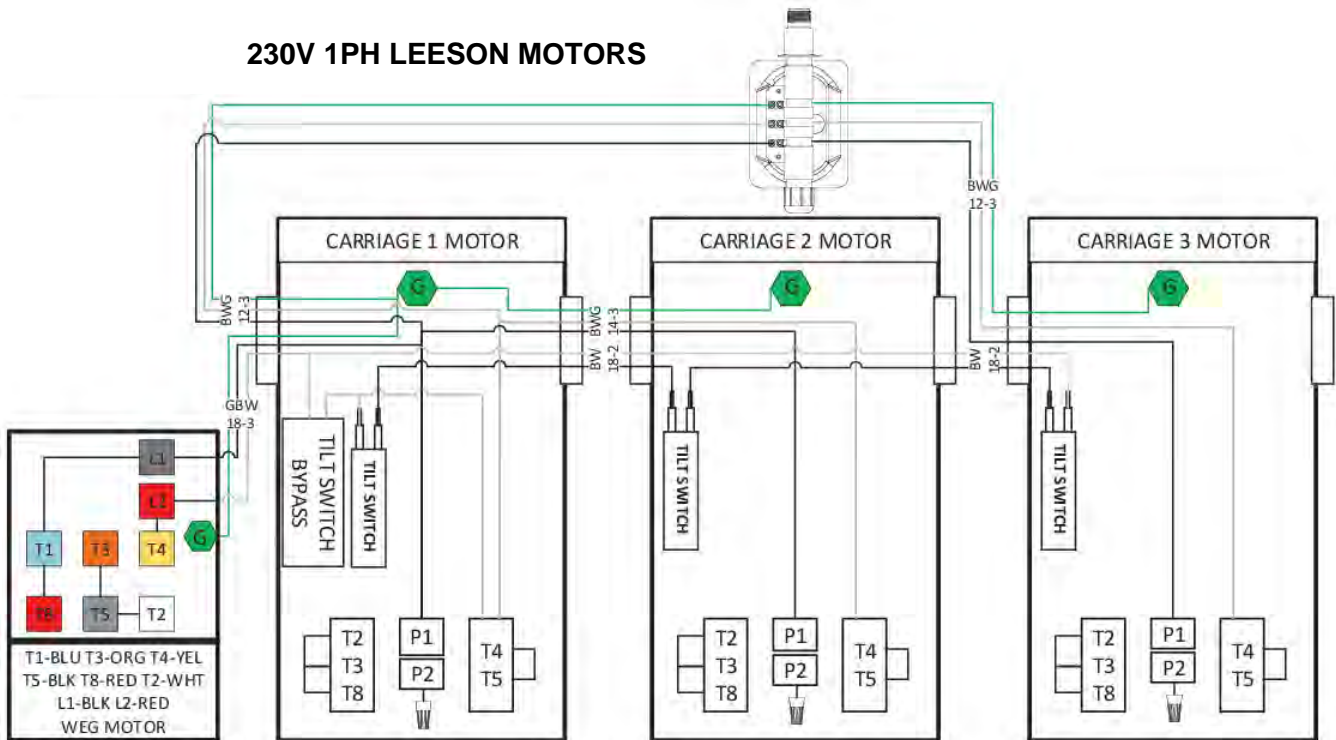

NOTE: Wiring for 1.5hp motor shown. For 2hp motor, lines T2-T3-T8 are replaced by T1-T8 and P2 is replaced by red wire.

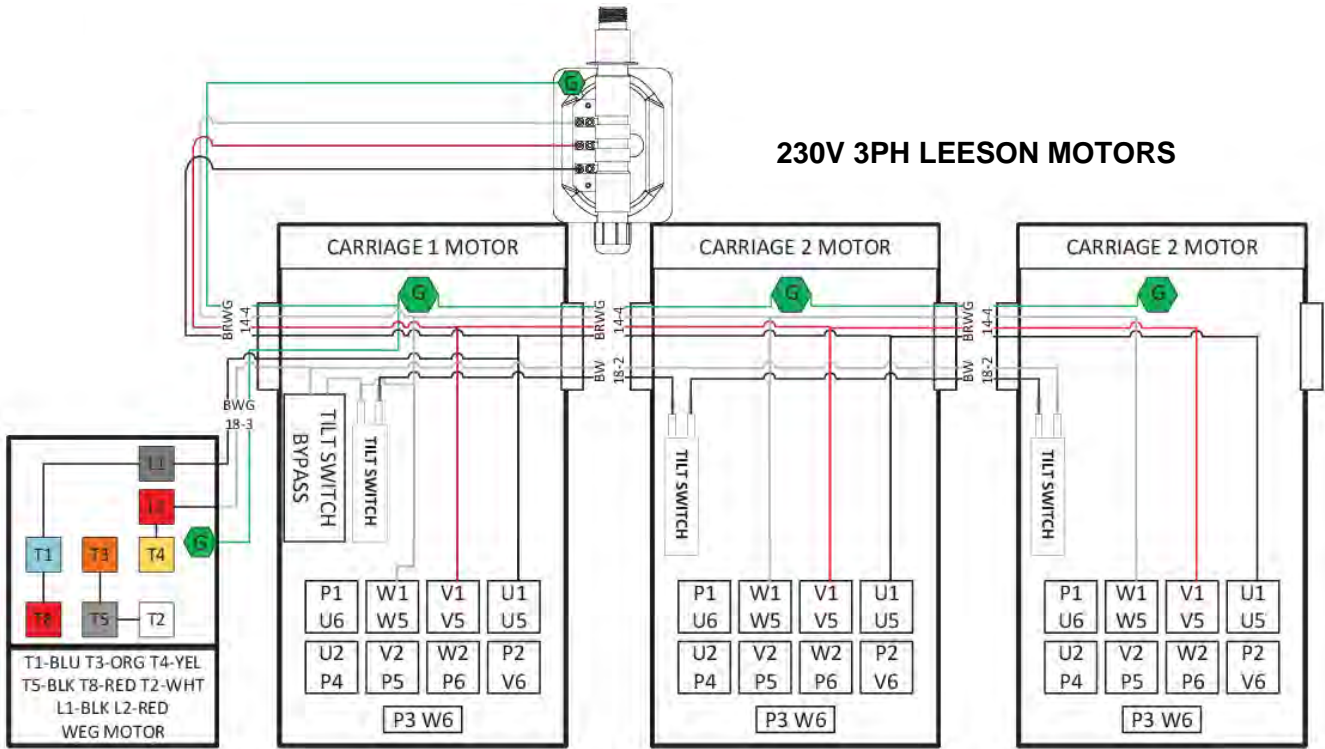

230V 3PH LEESON MOTORS

SWSM0068
06/05/2023 PBM

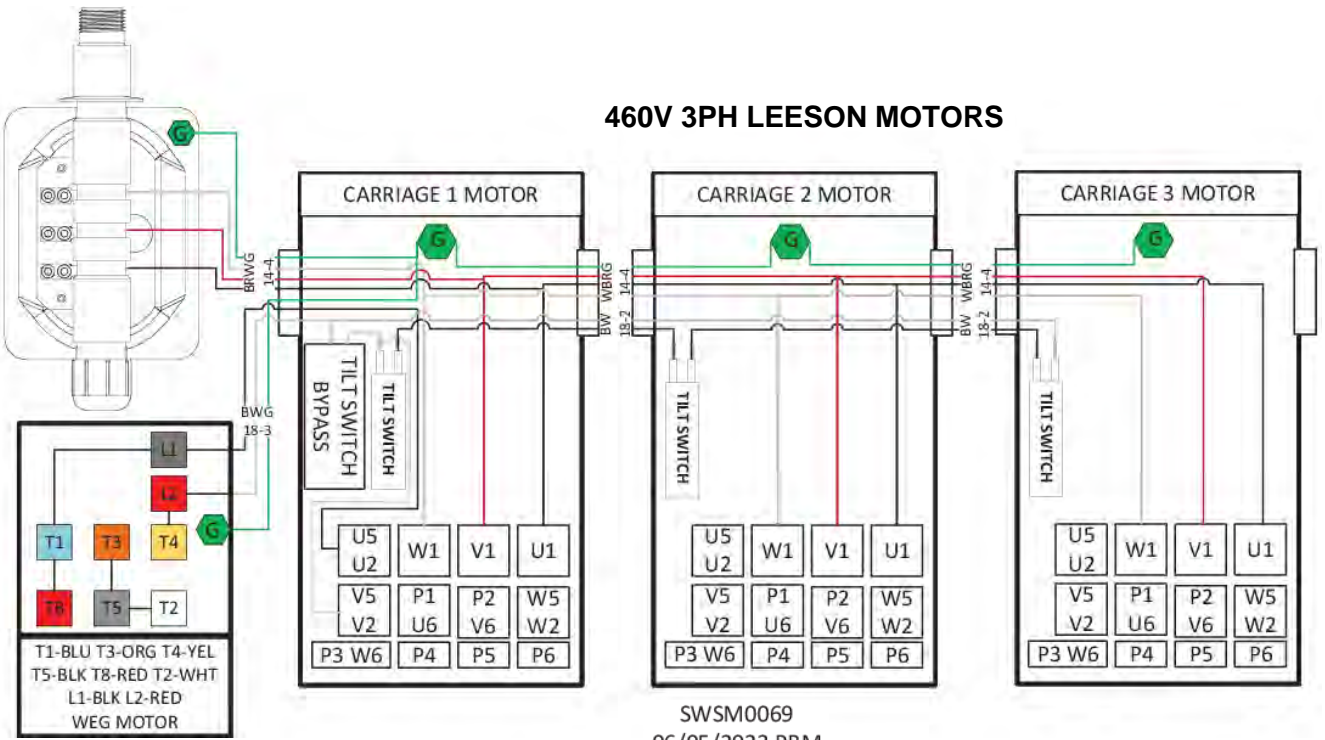

460V 3PH LEESON MOTORS

SWSM0069
06/05/2023 PBM

230V 1PH LEESON-MOTORS

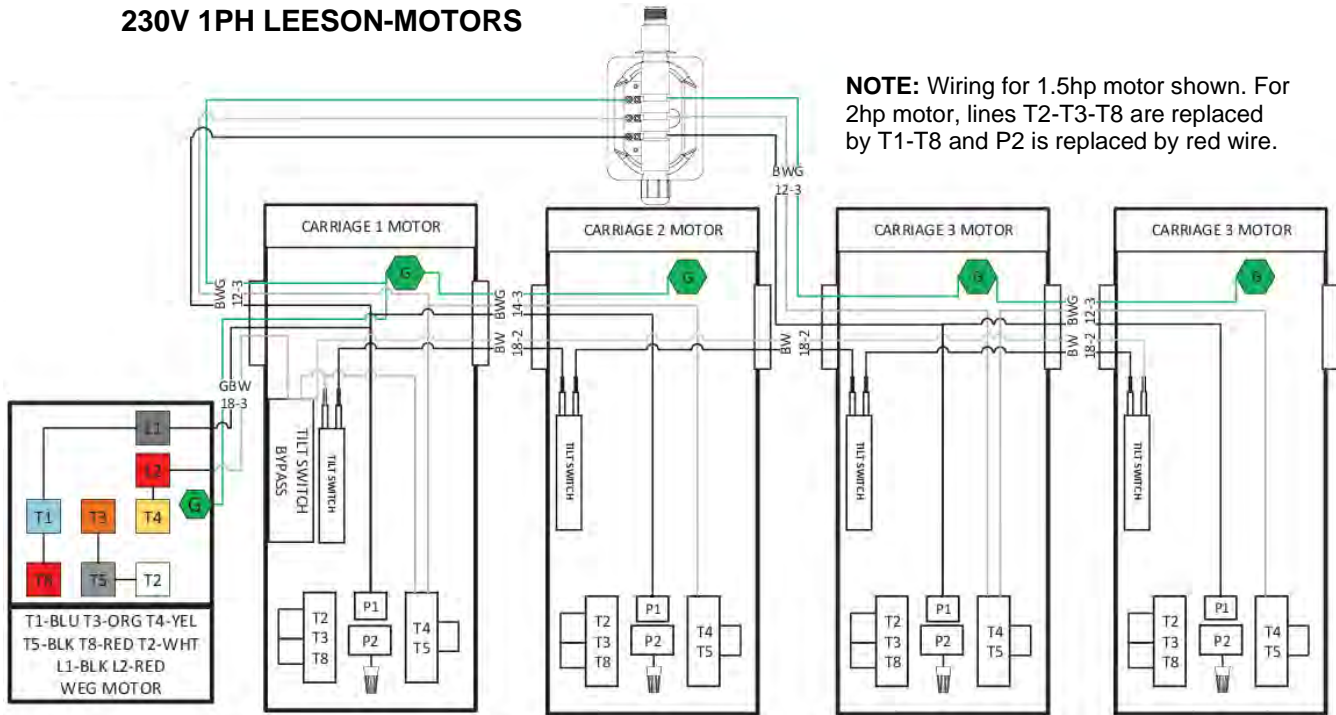

SWSM0070
07/19/2022 PBM

230V 3PH LEESON MOTORS

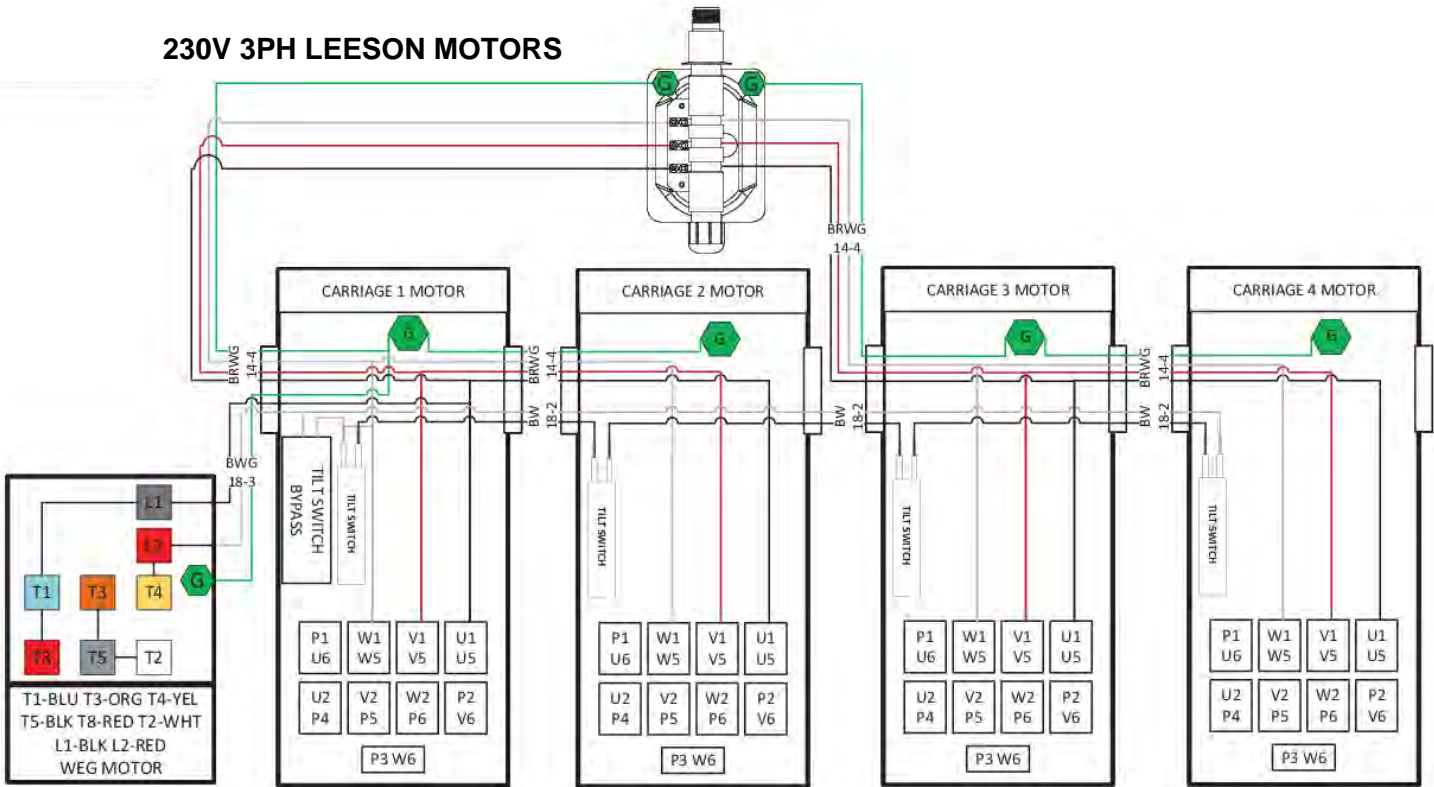

SWSM0071
06/05/2023 PBM

460V 3PH LEESON MOTORS

SWSM0072
06/05/2023 PBM

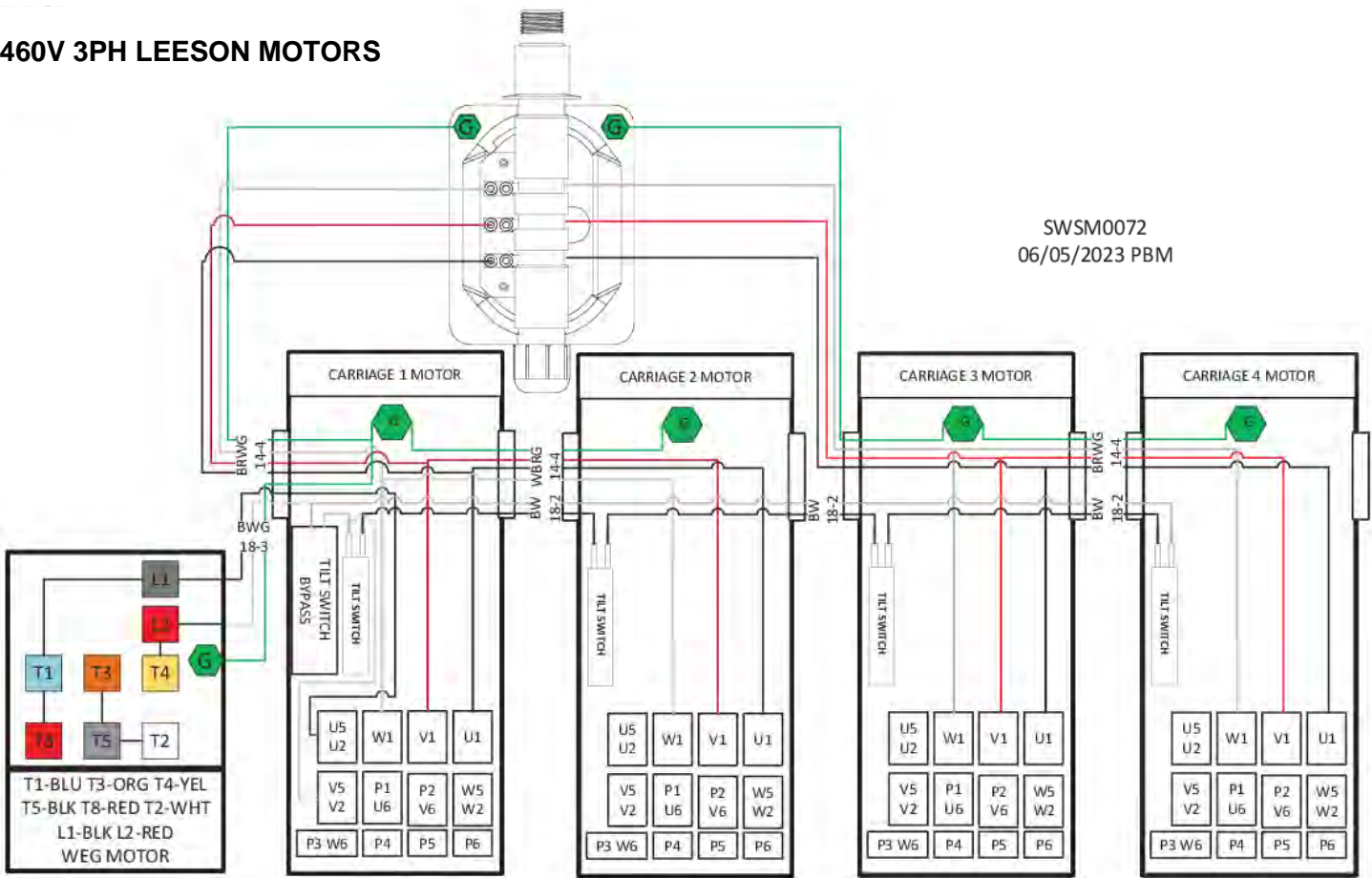

230V 1PH BALDOR MOTOR

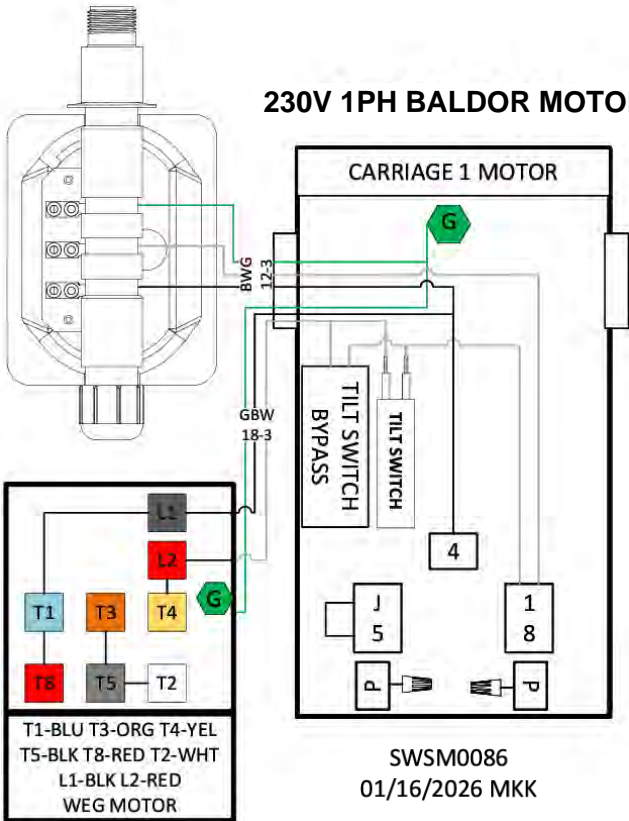

230V 3PH BALDOR MOTOR

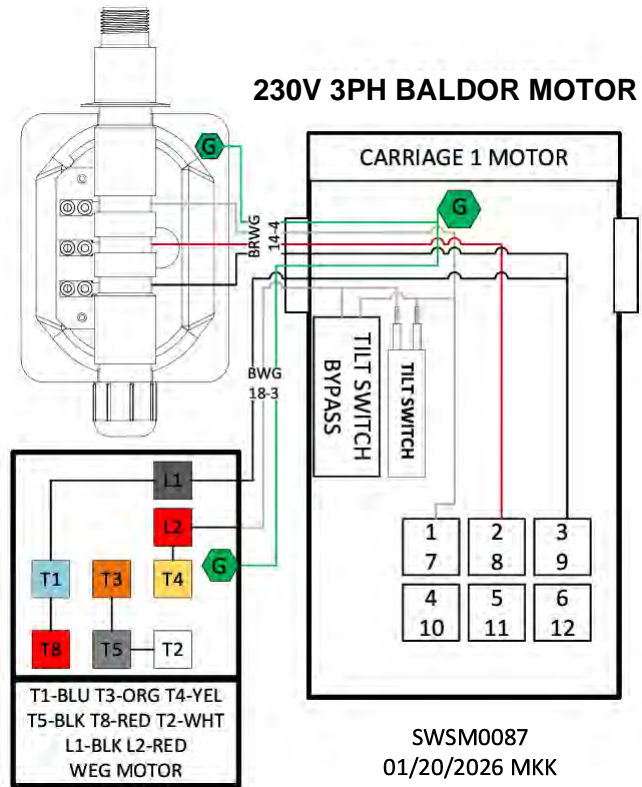

460V 3PH BALDOR MOTOR

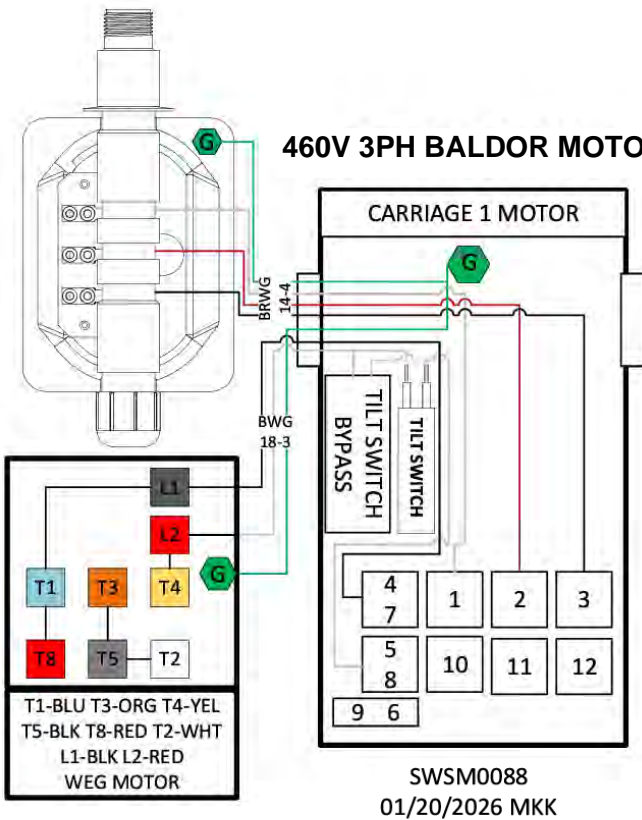

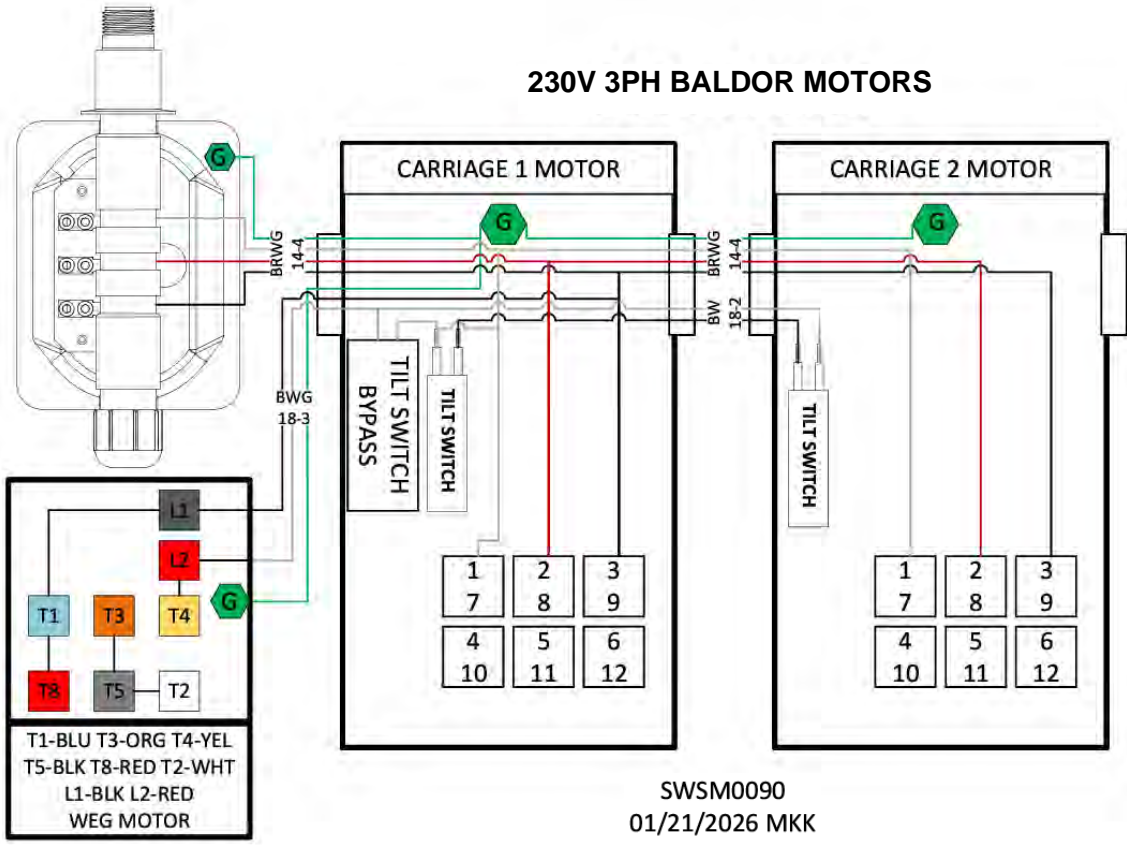
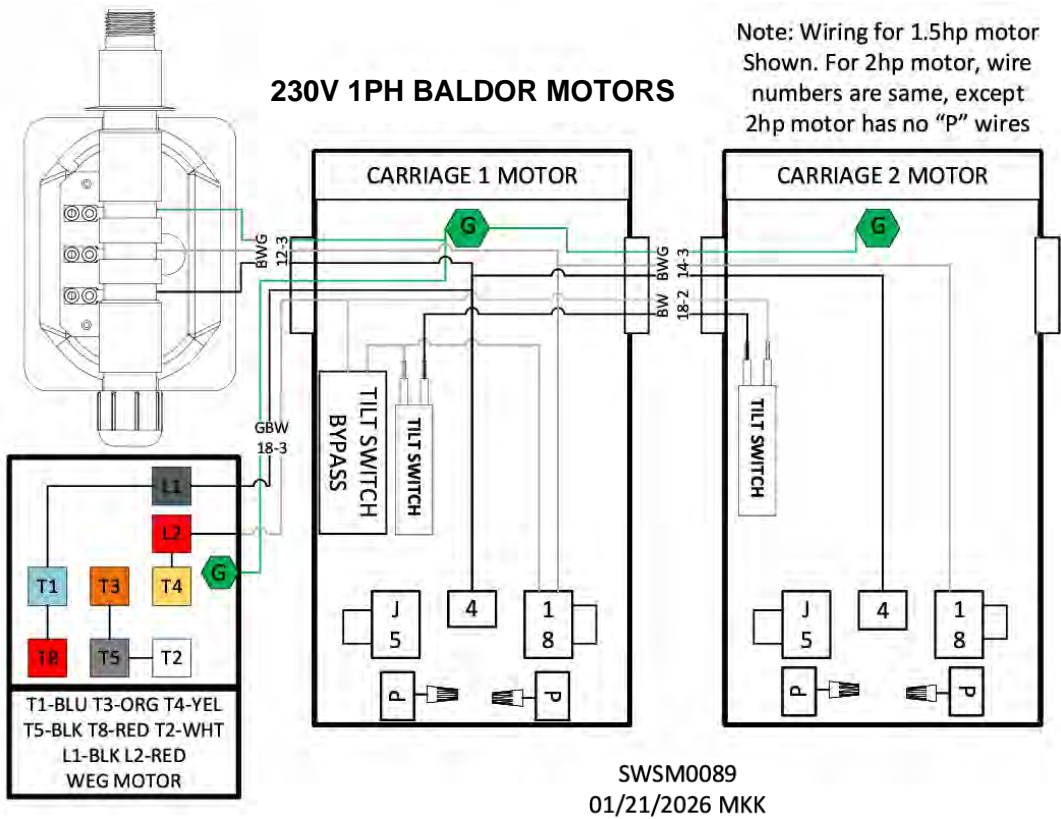

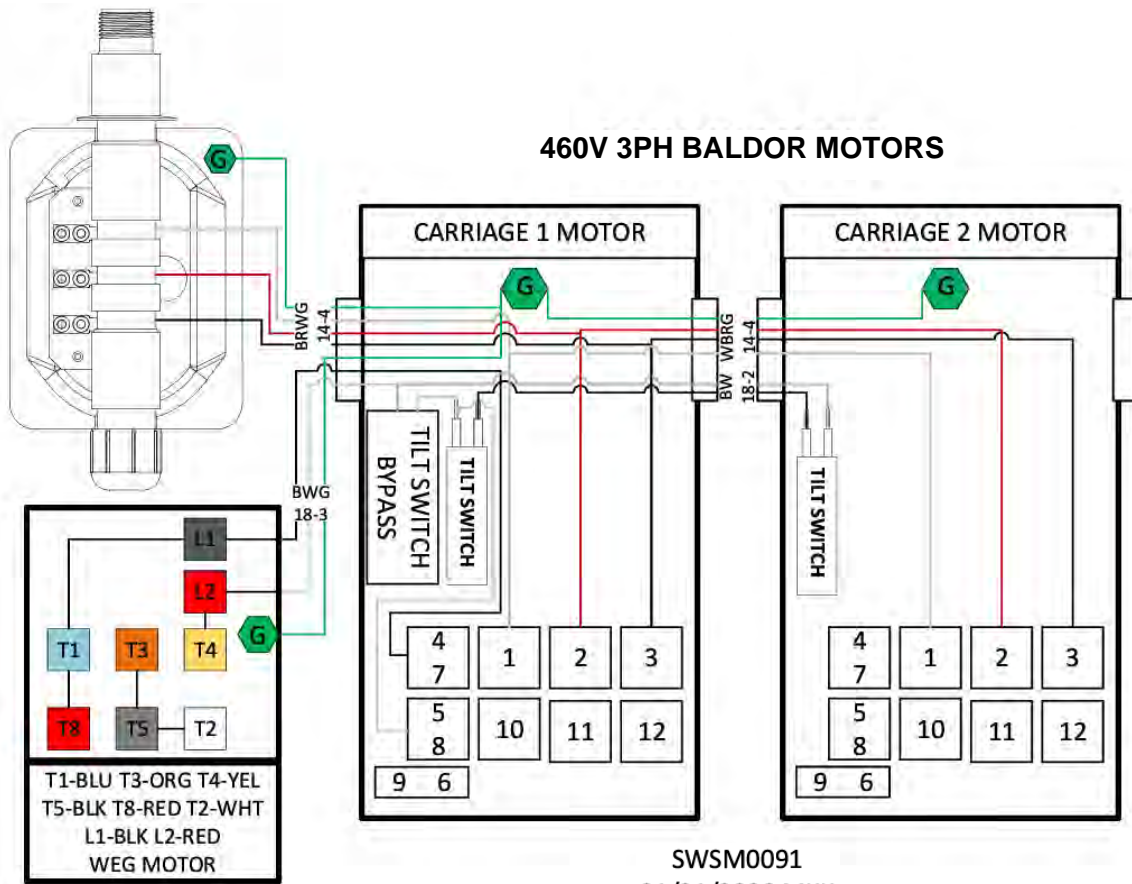

SWSM0092
01/21/2026 MKK

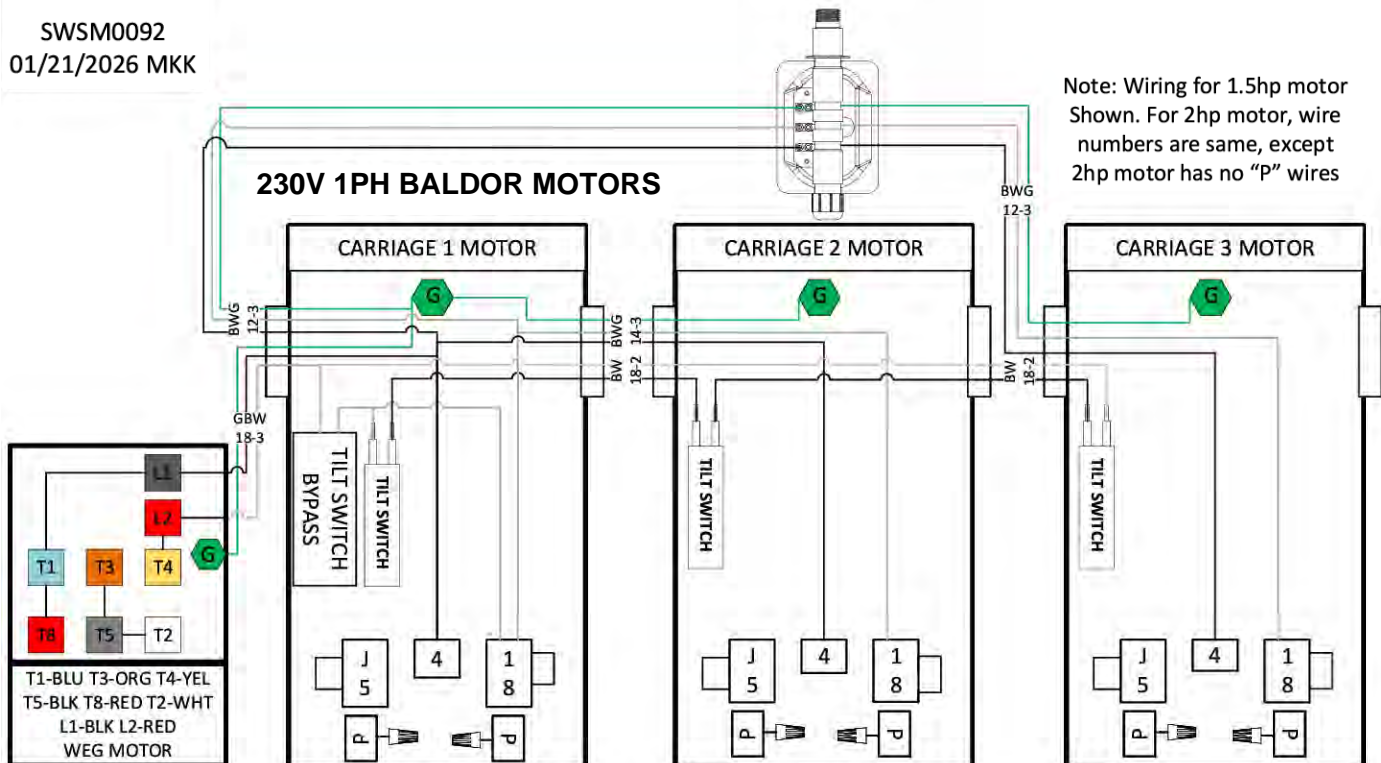

SWSM0093
01/21/2026 MKK

230V 3PH BALDOR MOTORS

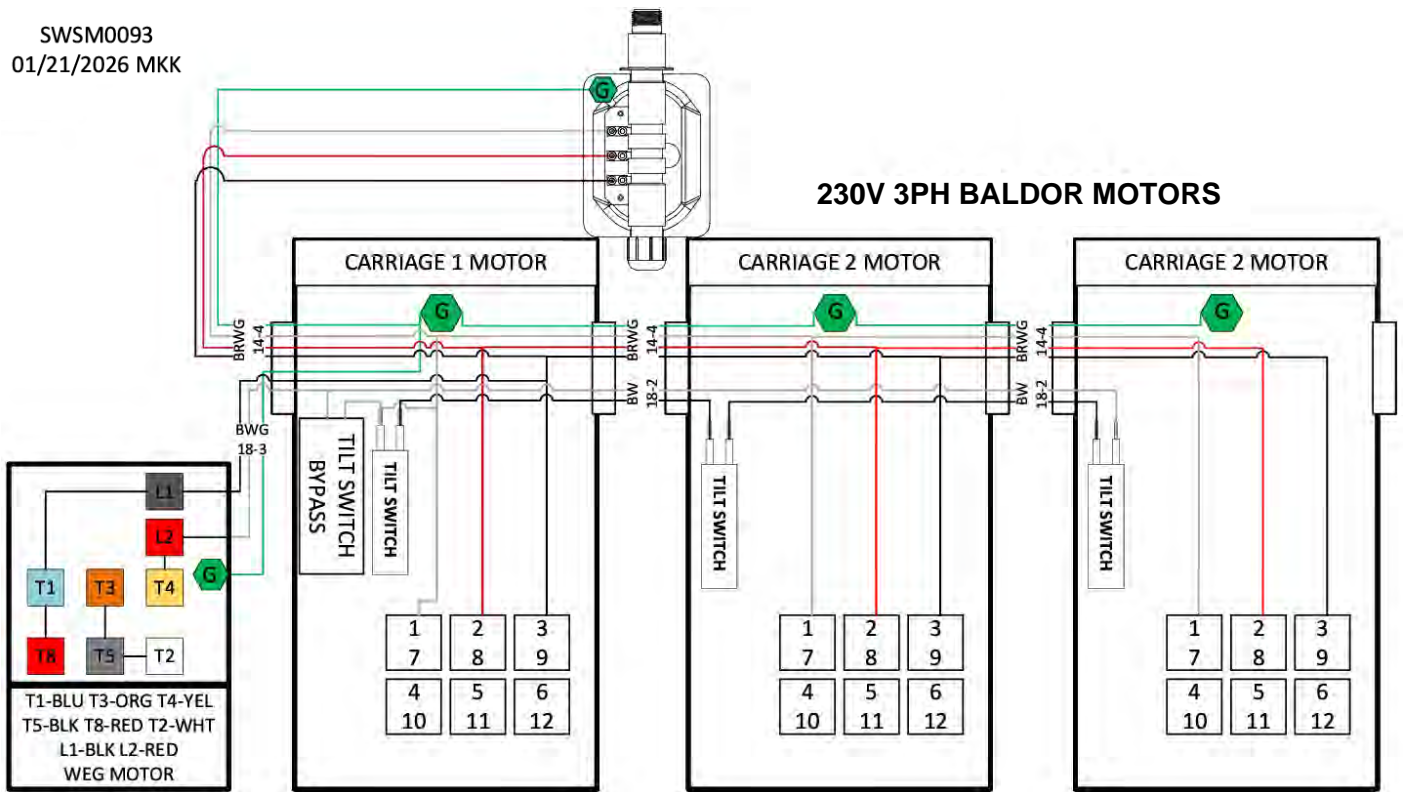

460V 3PH BALDOR MOTORS

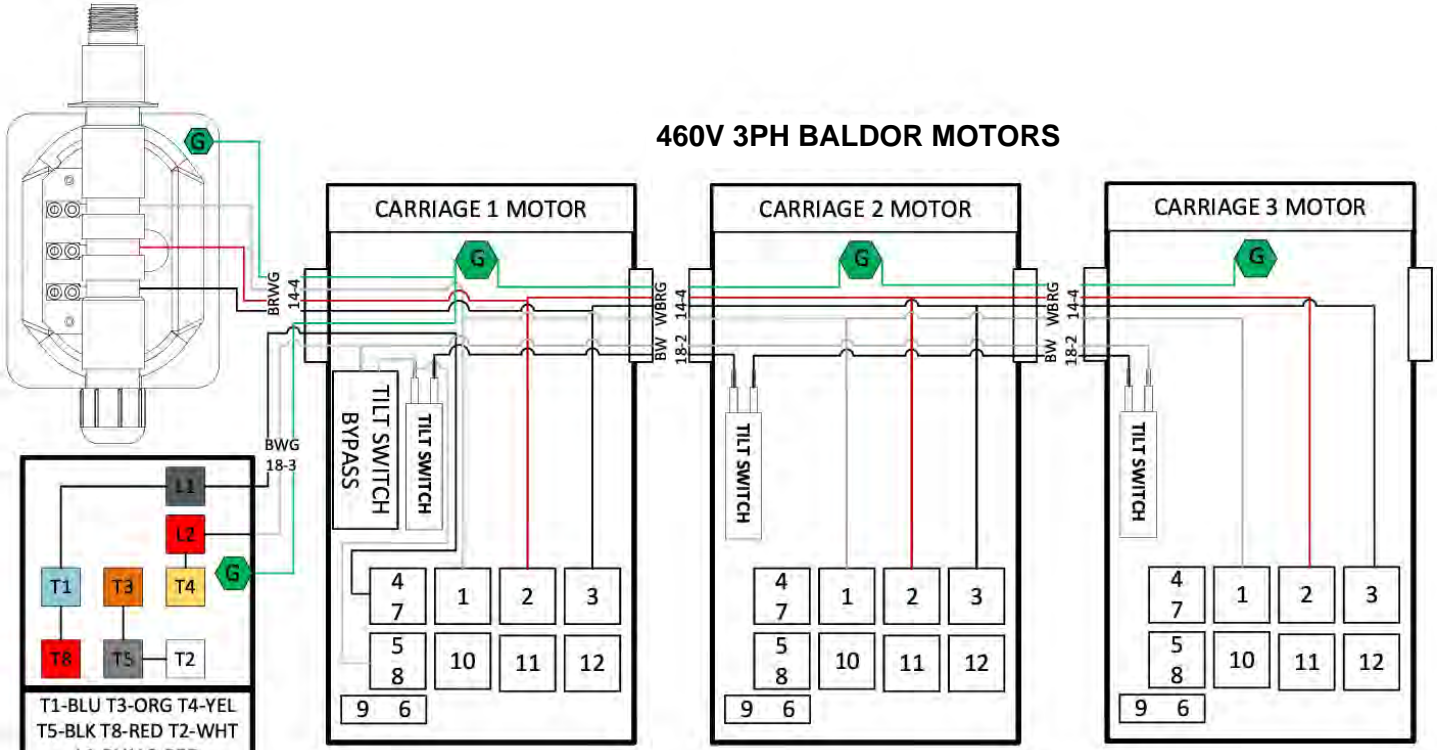

SWSM0094
01/21/2026 MKK

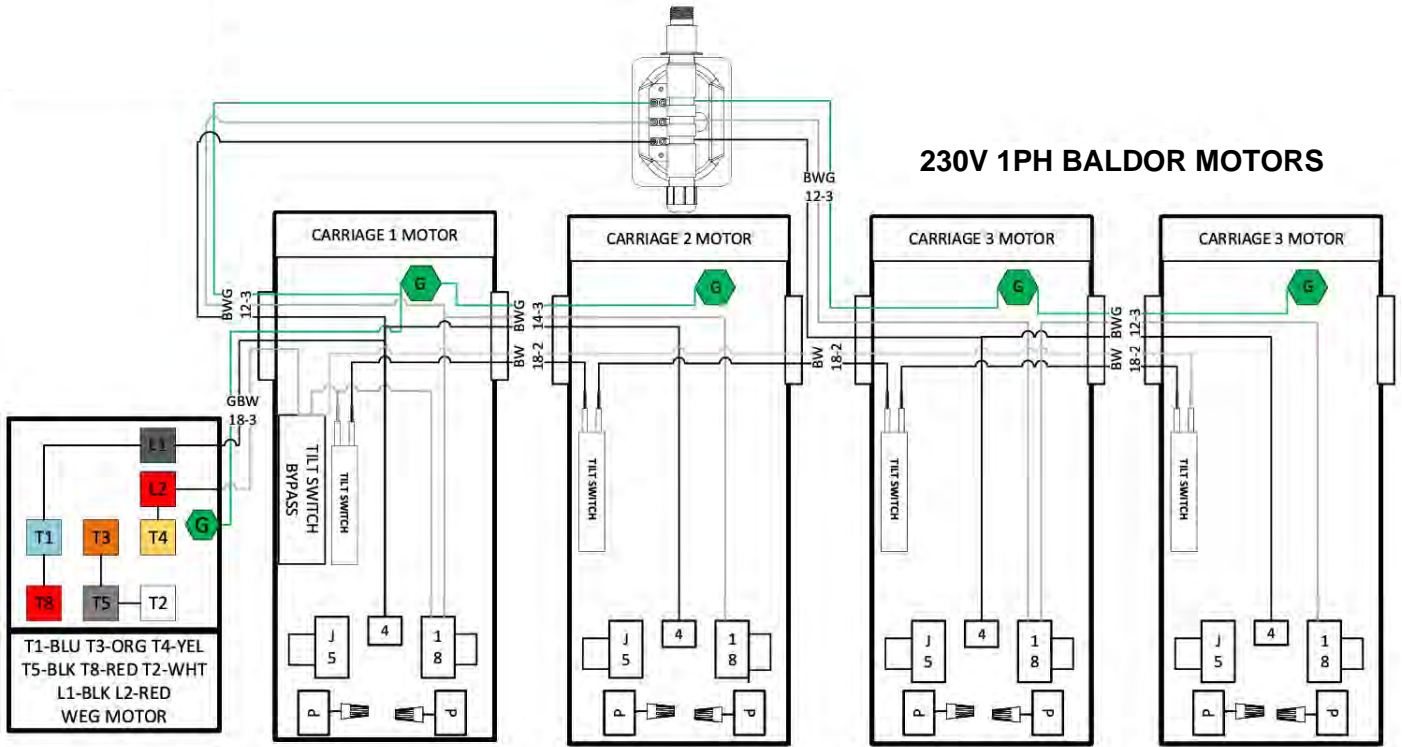

Note: Wiring for 1.5hp motor
Shown. For 2hp motor, wire
numbers are same, except
2hp motor has no "P" wires

SWSM0095
01/22/2026 MKK

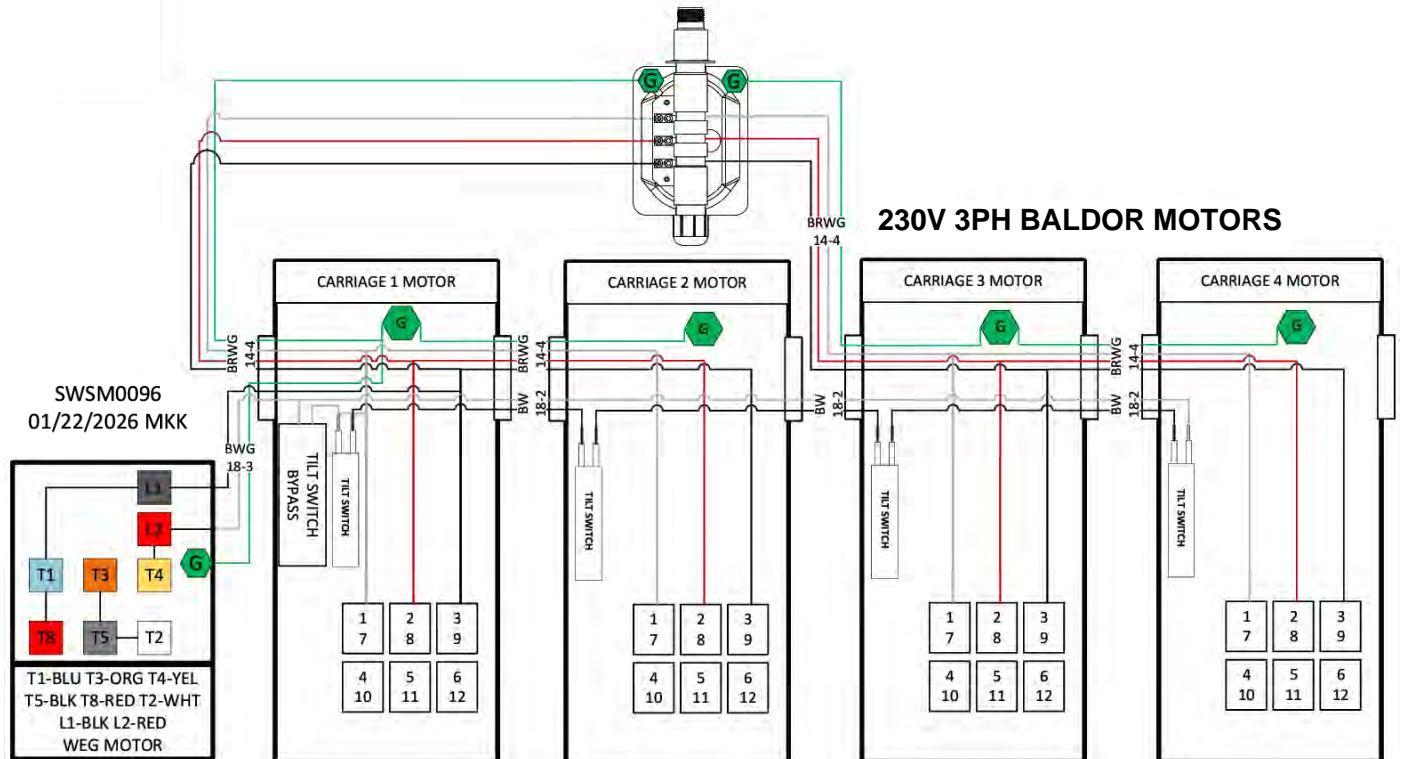

SWSM0096
01/22/2026 MKK

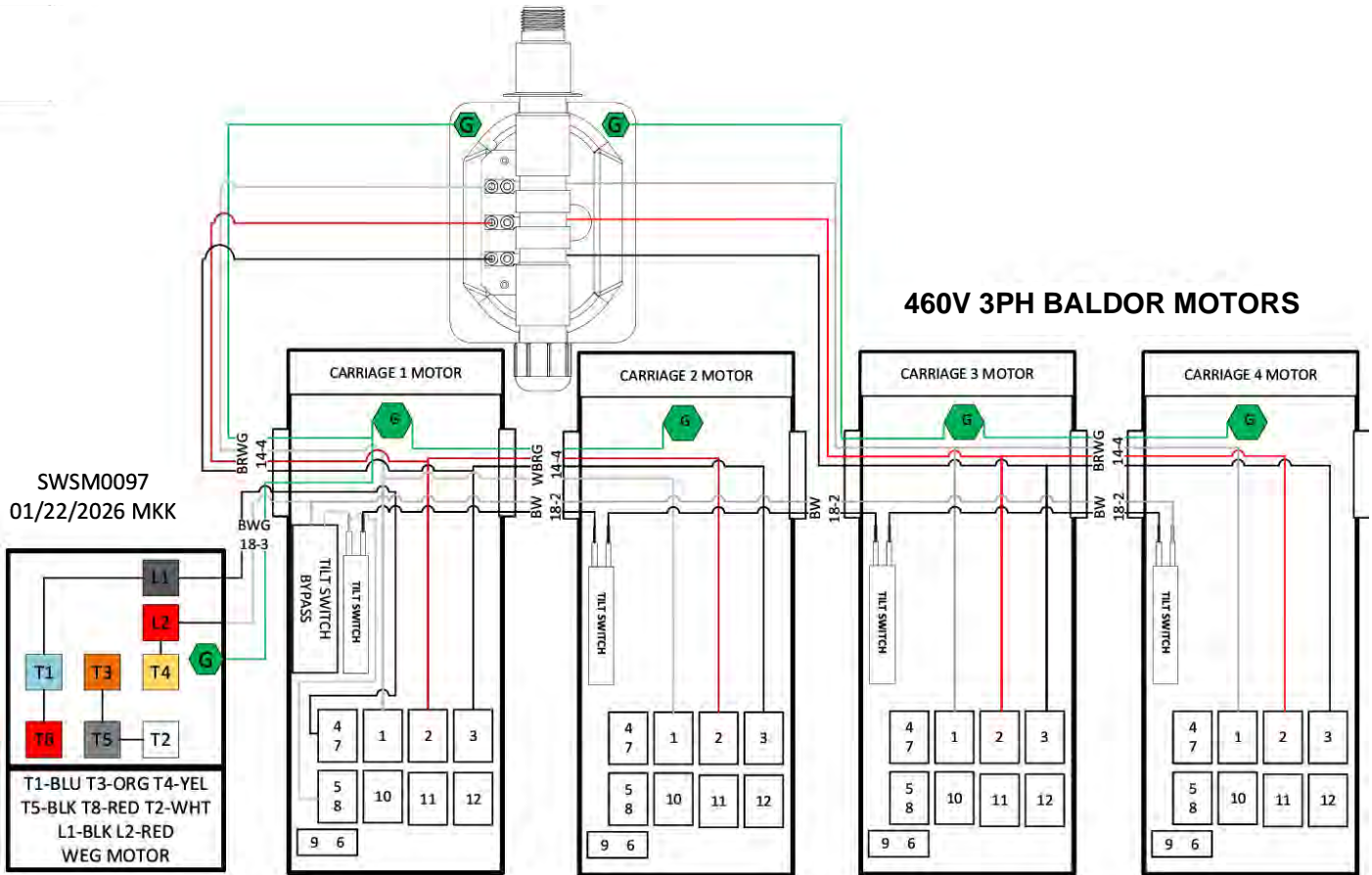



FASTIR PARTS/ASSEMBLIES

When ordering parts, always give part number (in **Part #** column) and part description shown alongside reference number. Do **not** order parts by reference numbers. If part number cannot be found in manual, give clear description of part and its location and function. Also, specify machine type and size.

TABLE OF CONTENTS

Track	61
Center Hanger Assembly	62
Pivoting Hanger	63
Reversing Mechanism	64
Wrap-Around Carriages	65
Primary Wrap-Around Carriage	66
Satellite Wrap-Around Carriage	68
Stationary Outside Carriage (Fastir Plus Only)	70
Electrical Junction Box	72
Rotating Contact	73
Cord Lengths	74
Electrical Components	75

TRACK

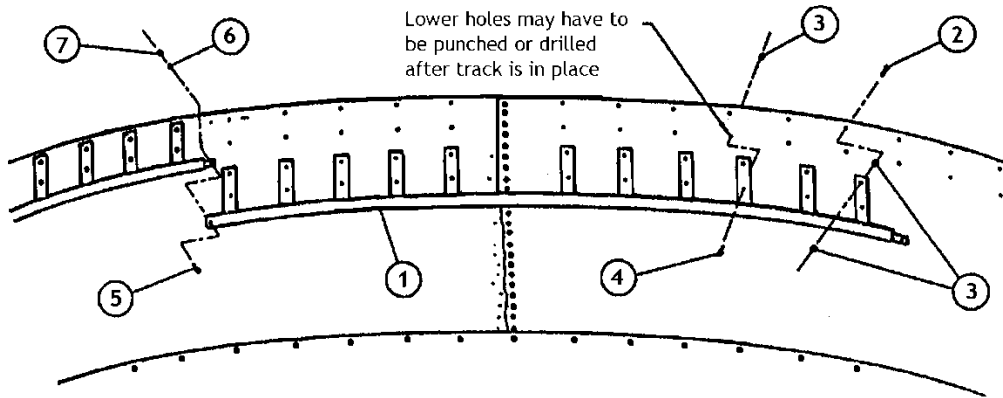

Ref. #	Description	Length	Qty.	Part #		
				Bundle	Piece	
1	Single-bracket track, 15' - 18' bin	(109-7/8")	1	A5700	A5719	
	Single-bracket track, 18' 7" bin	(114-3/4")	1	A5701	A5728	
	Bolt sack, 18' bin	-	1	A6810	-	
	Single-bracket track, 21' bin	(110")	1	A5702	A5720	
	* Single-bracket track, 21' 8" - 22' bin	(114-3/4")	1	A5703	A5728	
	Bolt sack, 21' bin	-	1	A6811	-	
	Single-bracket track, 23' 6" - 24' bin	(110-3/8")	1	A5704	A5721	
	Single-bracket track, 24' 8" bin	(114-3/4")	1	A5705	A5728	
	Bolt sack, 24' bin	-	1	A6812	-	
	Single-bracket track, 26' 6" - 27' bin	(110-3/4")	1	A5706	A5722	
	* Single-bracket track, 27' 10" - 28' bin	(114-3/4")	1	A5707	A5728	
	Bolt sack, 27' bin	-	1	A6813	-	
	Double-bracket track, 29' 4" - 30' bin	(110-7/8")	1	A5708	A5723	
	Double-bracket track, 31' bin	(114-3/4")	1	A5709	A5729	
	Bolt sack, 31' bin	-	1	A6814	-	
	Double-bracket track, 33' bin	(111")	1	A5710	A5724	
	Double-bracket track, 34' bin	(114-3/4")	1	A5711	A5729	
	Double-bracket track, 36' bin	(111-3/16")	1	A5712	A5725	
	Double-bracket track, 37' 1" bin	(114-3/4")	1	A5713	A5729	
	Bolt sack, 36' bin	-	1	A6815	-	
	Double-bracket track, 40' 2" - 42' bin	(111-3/8")	1	A5714	A5726	
	Bolt sack, 42' bin	-	1	A6816	-	
	Double-bracket track, 48' bin	(111-3/8")	1	A5715	A5727	
	Bolt sack, 48' bin	-	1	A6817	-	
	*Must include short track section (A5718)					
	Ref. #	Description	Sgl Brkt Qty.	Dbl Brkt Qty.	Part # (Bundle)	
2	Bolt, 5/16 - 18 x 1-1/4	7	11	B5952		
3	Nut, 5/16"	21	33	J1002		
4	Bolt, 5/16 - 18 x 1"	7	11	J0527		
5	For track splice: Bolt, 3/8 - 16 x 1"	-	1	J0606		
6	Lock washer, 3/8"	-	1	J1205		
7	Nut, 3/8" - 16	-	1	J1020		

Short track section parts list

Description	Qty.	Part #
Short track section, 18-1/2"	1	A5718
Bolt, 5/16 - 18 x 1-1/4" bin bolt	2	B5952
Nut, 5/16" - 18	4	J1002
Bolt, 5/16 - 18 x 1"	2	J0527
Bolt, 3/8 - 16 x 1"	1	J0606
Lock washer, 3/8"	1	J1205
Nut, 3/8" - 16	1	J1020

Short track section needed on some bins to complete track ring. Listed with short section is hardware needed to hang one piece.

CENTER HANGER ASSEMBLY

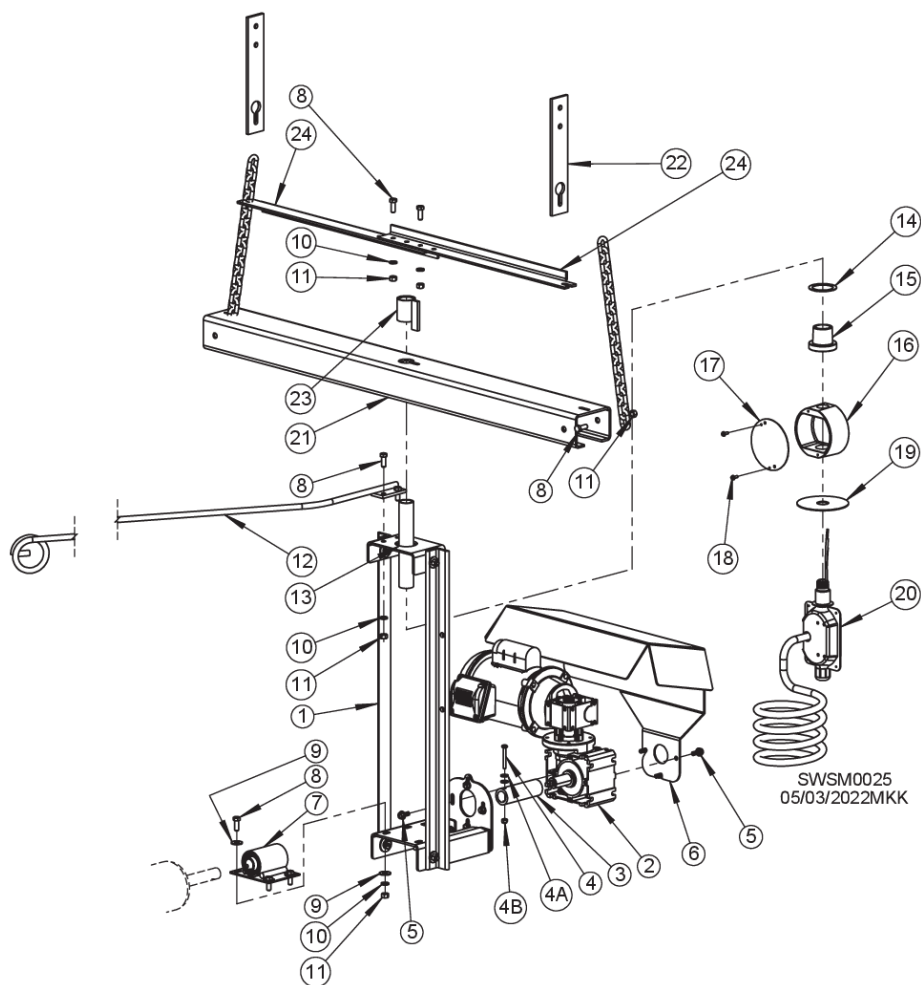

Ref. #	Description	Qty.	Part #	Ref. #	Description	Qty.	Part #
1	Pivoting hanger, 30", bolted	1	A7519	13	Hanger pipe, 8" x 1" (Bins 18' - 24' 2")	1	A5603
2	Gearmotor, 1/4hp	1	J3671		Hanger pipe, 24" x 1" (Bins 27' - 27' 10")	1	A5604
2A	Gearmotor reducer (Not shown)	1	J3671G		Hanger pipe, 32" x 1" (Bins 29' - 31')	1	A5605
2B	Motor, 1/4hp	1	H0035		Hanger pipe, 48" x 1" (Bins 33' - 37')	1	A5607
3	Long coupler	1	A75752		Hanger pipe, 72" x 1" (Bins 39' - 42')	1	A5606
4	Screw, 1/4 - 20 x 2"	1	J05133		Hanger pipe, 96" x 1" (Bins 48' - 49' 3")	1	A5608
4A	Flat washer, 1/4"	2	J1105	14	Brass washer	1	A5601
4B	Lock nut, 1/4"	1	J0992	15	Cast bushing	1	A5602
5	Screw, M8 x 16mm	7	J1352	16	Cast electric junction box	1	A5612
6	Gearmotor shield	1	A75191	17	Junction box cover	1	A5658
7	Pillow-block bearing, 1" * Pillow-block bearing, 1-1/4" Center bearing for pillow-block, 1"	1	A5649 A5651 J0030	18	Screw, 10 - 32 x 1/2", self-drill	3	J0478
	* Cntr. brng. for pillow-block, 1-1/4"		J0039	19	Drip plate	1	A5611
	Snap ring for pillow-block, 1"	2	J3597	20	Rotating contact (See Page 73 for size)	1	
	* Snap ring for pillow-block, 1-1/4"	2	J35982	21	Channel hanger	1	A4827
8	Bolt, 3/8" - 16 x 1"	8	J0606	22	Hanger, 11", large stirring machine	2	A7509
9	Flat washer, 3/8"	4	J1117	23	Coupling w/ tab	1	A56101
10	Lock washer, 3/8"	8	J1205	24	Chain spreader bar kit - optional (Kit includes hardware & instructions)	1	A5635
11	Nut, 3/8" - 16	8	J1020	25	Chain, 4-1/2' (Bins up to 22')	2	A4823
12	Cord hanger Cord hanger, extra long	1	A5609 A5598		Chain, 5-1/2' (Bins 22' 1" to 34')	2	A4824
					Chain, 6-1/2' (Bins 34' 5" on up)	2	A4825

* 40' & larger bins

PIVOTING HANGER (A7519)

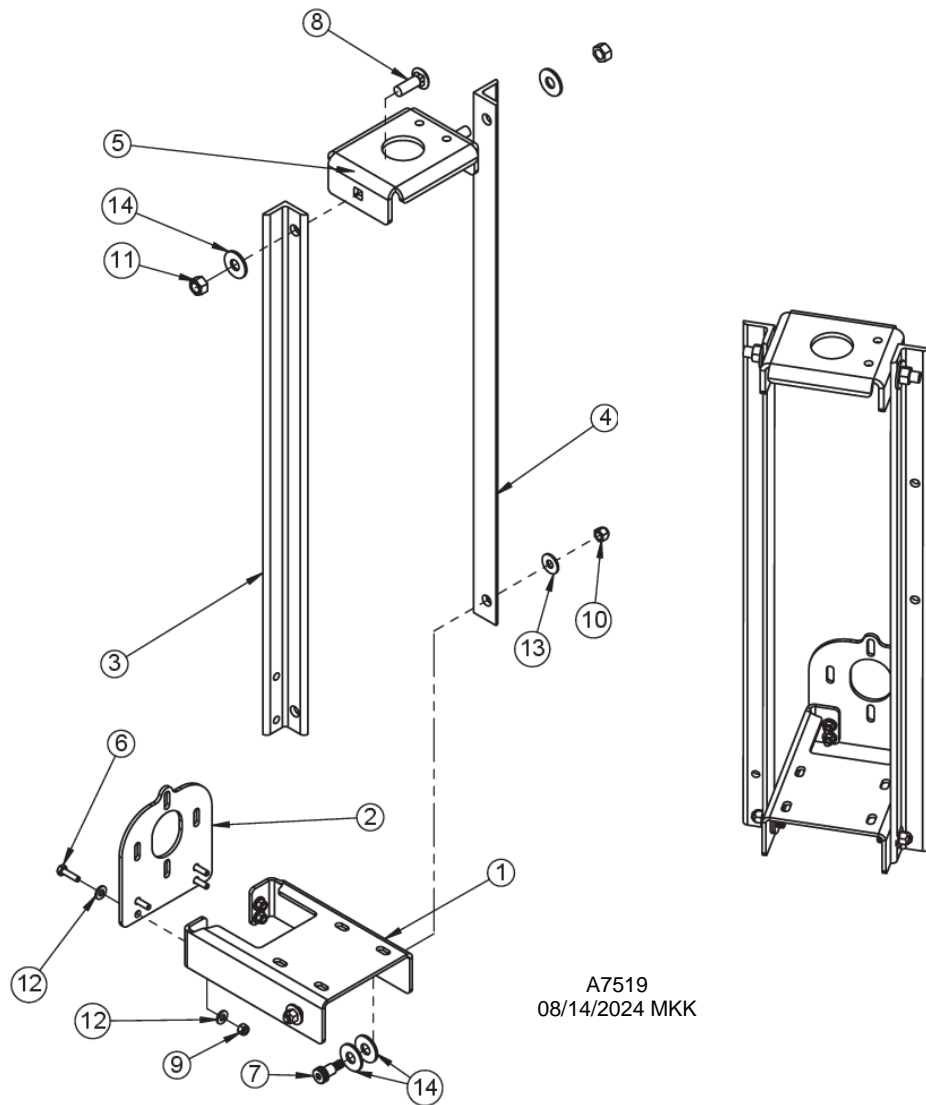

A7519
08/14/2024 MKK

Ref. #	Description	Qty.	Part #
1	Bracket base	A7519-01	1
2	Mounting plate	A7519-02	1
3	Vertical strap, 30", SB	A7519-03	1
4	Vertical strap, 30", AS	A7519-04	1
5	Hanger top	A75196	1
6	Screw, 1/4 - 20 x 1"	J0508	4
7	Shoulder bolt, 1/2 x 5/8"	J072291	2
8	Carriage bolt, 1/2-13 x 1-1/2"	J0739	2
9	Lock nut, 1/4" - 20	J0992	4
10	Lock nut, 3/8" - 16	J1024	2
11	Lock nut, 1/2" - 13	J1042	2
12	Flat washer, 1/4"	J1105	8
13	Flat washer, 3/8"	J1117	2
14	Flat washer, 1/2"	J1125	6

REVERSING MECHANISM

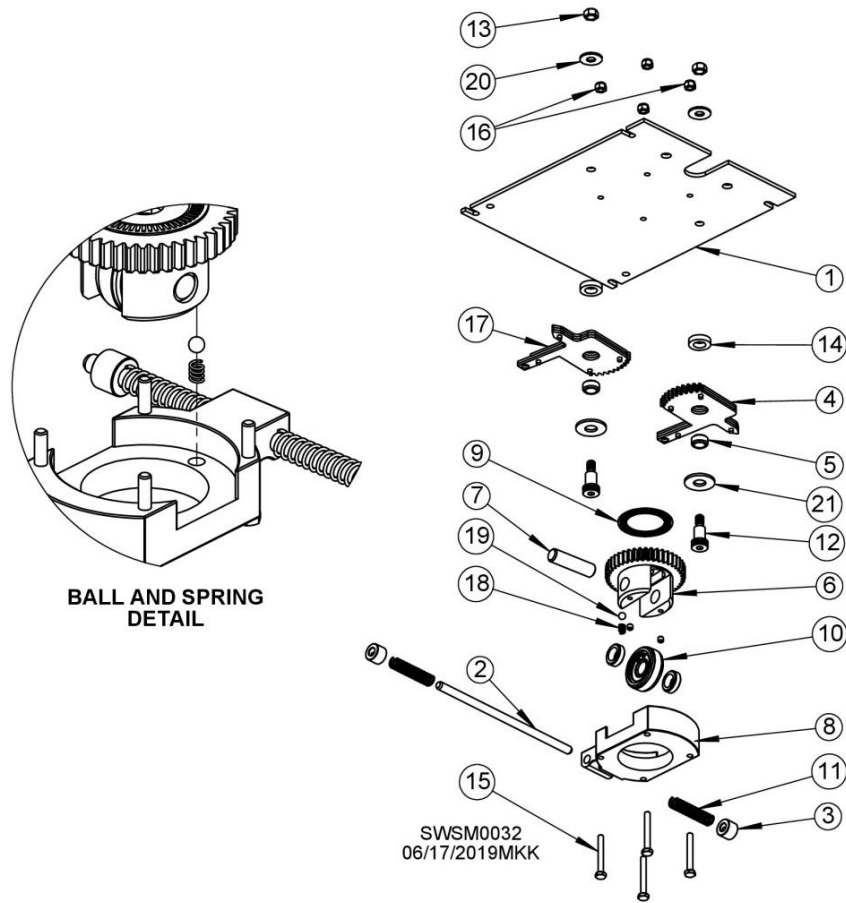

Ref. #	Description	Qty.	Part #
1	Reversing carriage plate	1	A5693
2	Reversing rod, 8-5/8" long	1	A80593
3	Shaft collar 3/8"	2	J1319
4	Toggle gear	1	A80453
5	Bushing, 1/2" x 3/4" x 5/8"	2	J00823
6	Directional gear	1	A8043
	Setscrews 1/4 x 1/4"	2	J1074
7	Pin, 2-3/8" long	1	A8044
8	Housing	1	A8042
9	Thrust bearing	1	J0058
10	Knurled drive bearing (Complete, w/ bushings)	1	A80691
	Knurled bearing	1	A8069
	Bushing, 1" OD x .339"	2	A8074
	Snap ring, 1.5652"	1	J3596
11	Compression spring, .054 x 3"	2	J23489
12	Bolt, 1/2 - 13 x 1-1/2"	2	J07229
13	Lock nut, 1/2" - 13	2	J1025
14	Machine bushing, 1/2" - 18ga	2	A85075
15	Bolt, 1/4 - 20 x 2"	4	J05134
16	Lock nut, 1/4" - 20	4	J0992
17	Reversing gear	1	A80452
18	Compression spring, 5/16" OD x .54"	1	J2363
19	Ball, steel, 5/16"	1	J3308
20	Flat washer, 3/8"	2	J1117
21	Flat washer, 1/2"	2	J1125

WRAP-AROUND CARRIAGES

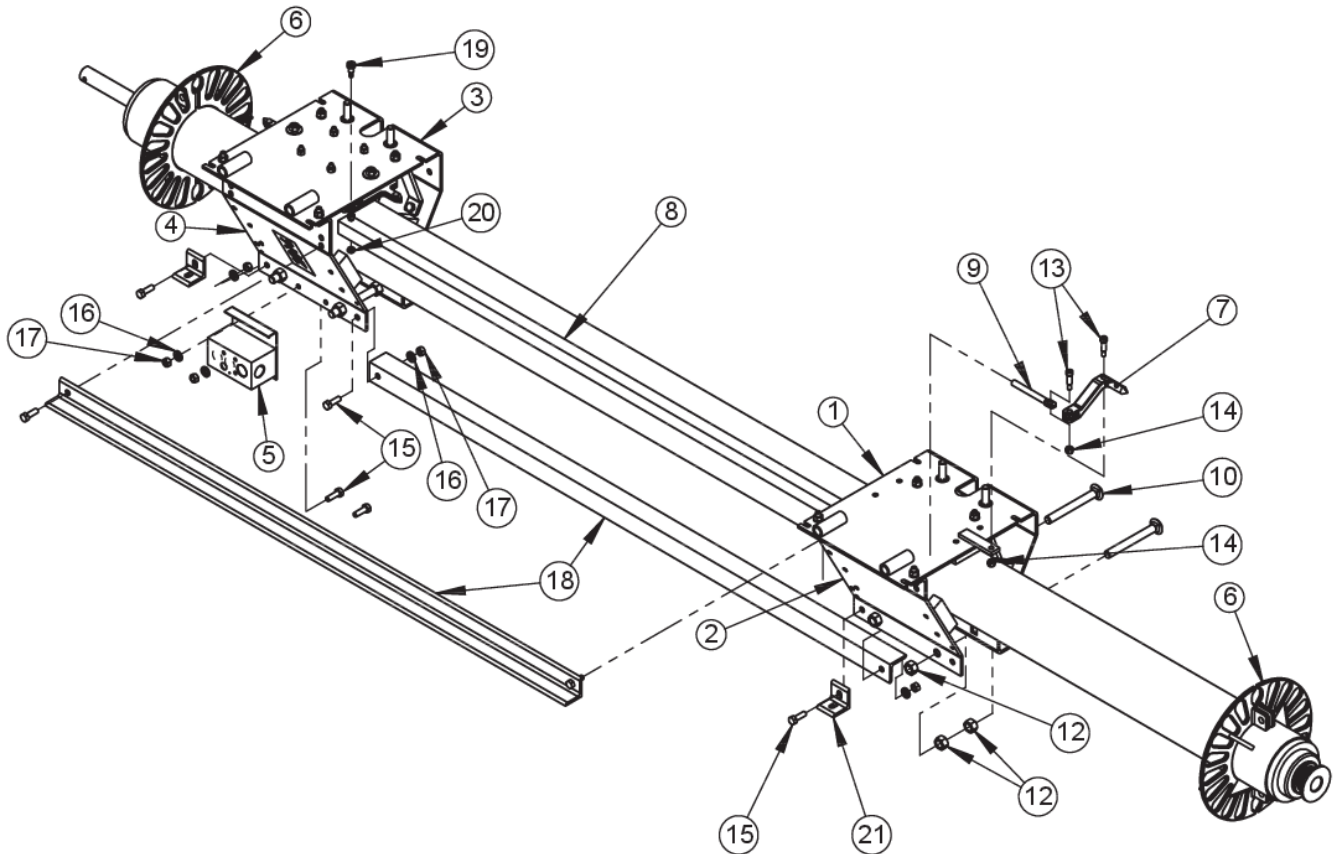

SWSM0030
06/16/2020MKK

Ref. #	Description	Qty.	Part #	
			4-1/2" Crosstubes	5-1/2" Crosstubes
1	Satellite carriage, assembled	1	A8502	A6135
	Satellite body	1	A5696	A6105
2	Satellite wing	1	A5697	A6111
3	Primary carriage, assembled	1	A8501	A6130
	Primary body	1	A5693	A6100
4	Primary wing	1	A5694	A6110
5	Junction box	1	A8139	A8139
6	Complete reversing plate assy. w/ hardware	2	A8034	A8049
	Reversing carriage plate, (1/2 plate)	4	A80342	A8060
7	Toggle arm	1	A8505	A8505
8	Reversing rod	1	Specify machine size	Specify machine size
9	Hanger bolt	1	A8550	A8550
10	Carriage bolt,	4	J07592	J07611
11	Lock washer, 1/2" (Not shown)	4	J1215	J1215
12	Nut, 1/2"	12	J1040	J1040
13	Shoulder bolt, 5/16", 3/4", 1/4" - 20 thread	2	J0521	J0521
14	Lock nut, 1/4" - 20	2	J0992	J0992
15	Bolt, 5/16" x 1"	7	J0527	J0527
16	Lock washer, 5/16"	7	J1205	J1205
17	Nut, 5/16"	7	J1002	J1002
18	Tie bar	2	Specify machine size	Specify machine size
19	Shoulder bolt, 8 mm, 10, 6 mm thread	1	J0538	J0538
20	Lock nut, 6mm	1	J0998	J0998
21	Stabilizer arm bracket	2	A4545	A4545

PRIMARY WRAP-AROUND CARRIAGE

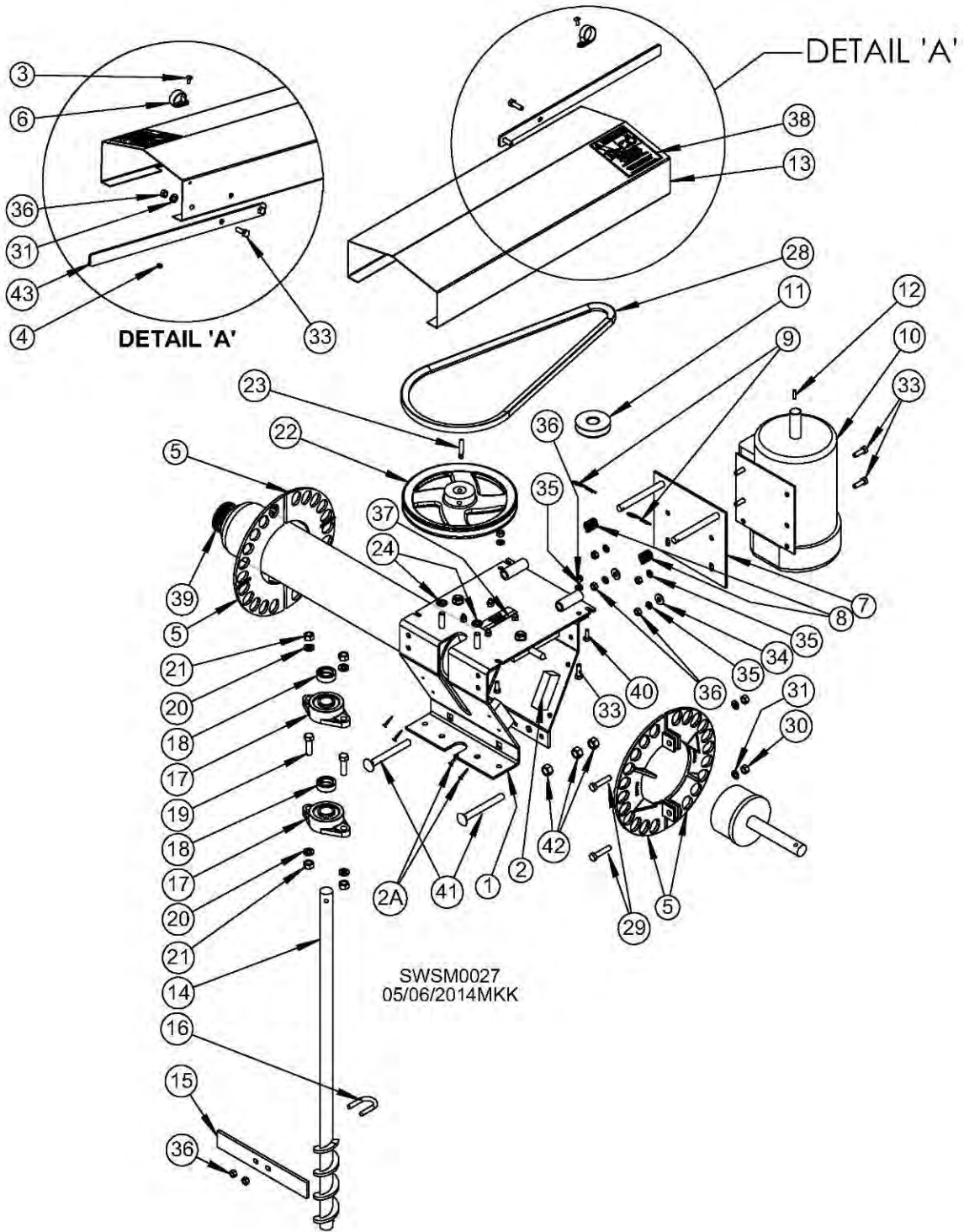

PRIMARY WRAP-AROUND CARRIAGE PARTS LIST

Ref. #	Description	Qty.	Part #	
			4-1/2" Crosstubes	5-1/2" Crosstubes
1	Primary carriage	1	A8501	A6130
2	Bearing block	4	A8507	A8507
2A	Screw, 1-1/8"	8	J0463	J0463
3	Machine screw #10 - 24 x 1/2"	1	J0514	J0514
4	Nut, #10 - 24	1	J0985	J0985
5	Reversing carriage plate	4	A80342	A8060
6	Cord holder	1	A5637	A5637
7	Motor mount	1	A5209	A5209
8	Compression spring, 1-1/2" x 1/2" ID	2	J2365	J2365
9	Hairpin clip	2	J5410	J5410
10*	Motor, "S", 1-1/2hp, 1ph, 230V Motor, "A", 1-1/2hp, 1ph, 230V Motor, "S", 1-1/2hp, 3ph, 230V Motor, "A", 1-1/2hp, 3ph, 230V Motor, "S", 1-1/2hp, 3ph, 460V Motor, "A", 1-1/2hp, 3ph, 460V (Motor includes pulley and key) ("A" Motors wired w/ 9'6" replacement leads) See Page 74 for correct cord lengths & #s		A7721 A7721 A7732 A7732 A7735 A7735	A7721 A7721 A7732 A7732 A7735 A7735
	Receptacles (Not shown) Plug, male, 3-prong - 1ph Plug, female, 3-prong, arm - 1ph Plug, male, 4-prong, arm - 3ph Plug, female, 4-prong, arm - 3ph		J3715 J3720 J3725 J3730	J3715 J3720 J3725 J3730
11	Pulley, 2-3/4" x 7/8", "A"	1	J0295	J0295
12	Key, 3/16" sq. x 3/4"	1	A7522	A7522
13	Center carriage shield	1	A8508	A6120
14	Down auger - 15' 6" standard, other sizes optional	1	A4210	A4210
15	Flinger	1	A5616	A5616
16	U-bolt, 5/16" - 18 x 1-3/4"	1	J0810	J0810
17	Flange bearing, 1"	2	J0003	J0003
18	Locking collar	2	J0067	J0067
19	Bolt, 7/16" - 14 x 1-1/2"	4	J0710	J0710
20	Lock washer, 7/16"	4	J1210	J1210
21	Nut, 7/16" - 14	4	J1035	J1035
22	Pulley, 9", "A" groove w/pin hole	1	J0355	J0355
23	Rollpin, 5/16" x 2-1/4"	1	J1510	J1510
24	Push nut, 7/16"	2	J1036	J1036
28	Belt	1	J0179	J0195
29	Bolt, 3/8" - 16 x 1-3/4", tap	4	J0640	J0640
30	Nut, 3/8"-16	4	J1020	J1020
31	Split lock washer, 3/8"	4	J1205	J1205
33	Bolt, 5/16" - 18 x 1"	6	J0527	J0527
34	Flat washer, 5/16"	8	J1111	J1111
35	Lock washer, 5/16"	6	J1200	J1200
36	Nut, 5/16" - 18	8	J1002	J1002
37	Decal, Replace Shield	1	L0271	L0271
38	Decal, Warning	1	L0284	L0284
39	Outer slug w/ drive wheel	1	A8085	A8089
40	Bolt, 1/4" - 20 x 3/4"	2	J0505	J0505
41	Carriage bolt	2	J07592	J07611
42	Nut, 1/2" - 13	6	J1040	J1040
43	Cord support strap	1	A6121	A6121

*Part numbers shown are for Leeson motors. Add "B" to end of part number for Baldor motor.

SATELLITE WRAP-AROUND CARRIAGE

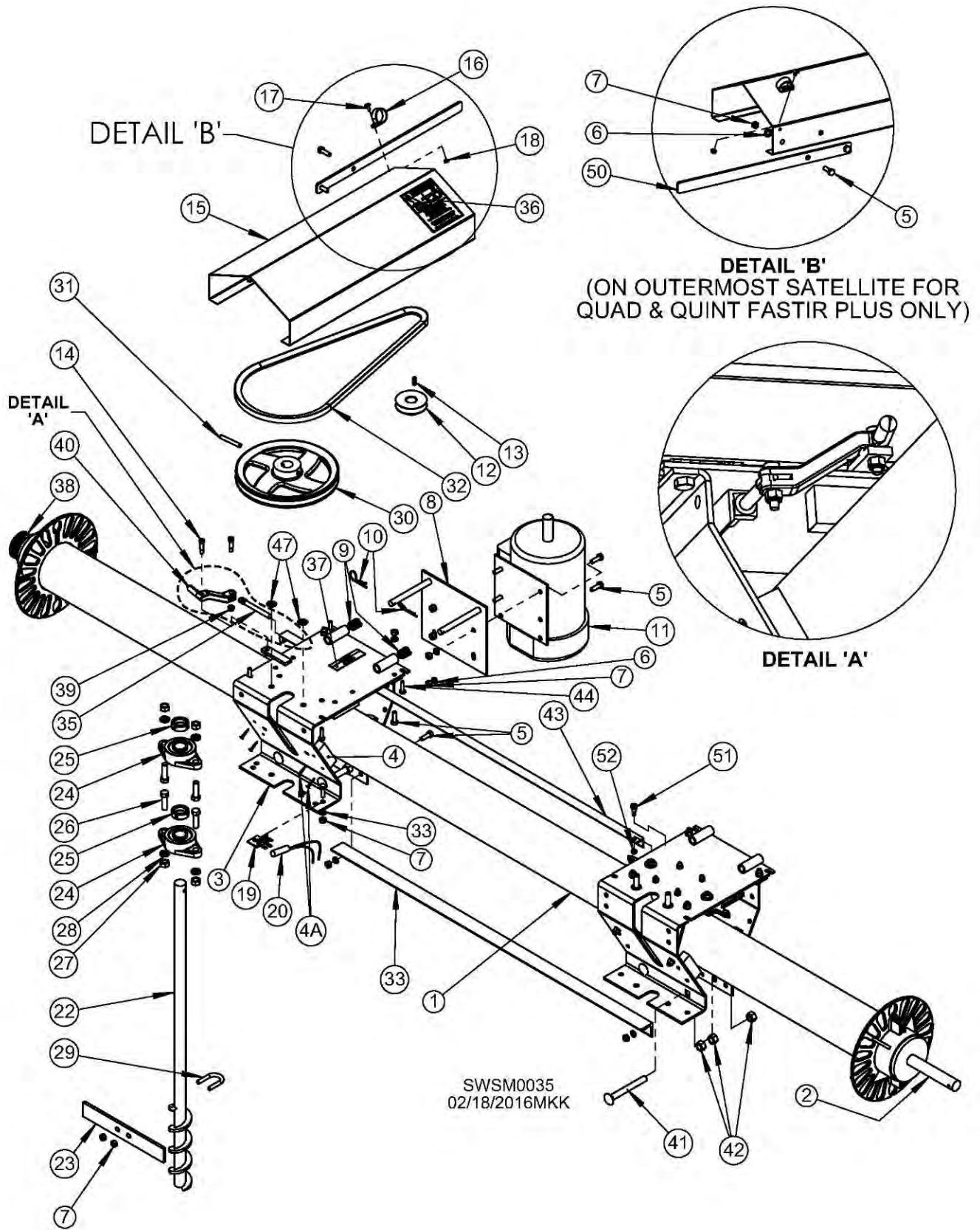

SATELLITE WRAP-AROUND CARRIAGE PARTS LIST

Ref. #	Description	Qty.	Part #	Part #
			4-1/2" Crosstube	5-1/2" Crosstube
1	Crosstube, 18' - 18' 7" bin	1	A8126	-
	Crosstube, 21' - 21' 8" bin	1	A8128	-
	Crosstube, 24' - 24' 9" bin	1	A8130	-
	Crosstube, 27' - 27' 10" bin	1	A8132	-
	Crosstube, 30' - 31' bin	1	A8134	-
	Crosstube, 33' - 34' bin	1	A8136	-
	Crosstube, 36' - 37' 1" bin	1	A8138	-
	Crosstube, 42' - 42' 8" bin	1	A81381	A81372
	Crosstube, 48' bin	1	A81382	A81371
2	Inner slug, 1" shaft	1	A4822	-
	*Inner slug, 1-1/4" shaft	1	A4807	A4817
3	Satellite carriage w/ bearing block	1	A8502	-
3A	Satellite carriage w/ bearing	1	A8504	A6135
4	Bearing block	6	A8507	A8507
4A	Screw, 1-1/8"	12	J0463	J0463
5	Bolt, 5/16" - 18 x 1"	7	J0527	J0527
6	Split lock washer, 5/16"	7	J1200	J1200
7	Nut, 5/16"	9	J1002	J1002
8	Motor mount	1	A5209	A5209
9	Spring, 1-1/2" x 1/2" ID	2	J2365	J2365
10	Hairpin clip	3	J5410	J5410
11	Motor, "O", 1-1/2hp, 1ph, 230V (See Page 75). Motor, "B", 1-1/2hp, 1ph, 230V " " " Motor, "O", 1-1/2hp, 3ph, 230V " " " Motor, "B", 1-1/2hp, 3ph, 230V " " " Motor, "O", 1-1/2hp, 3ph, 460V " " " Motor, "B", 1-1/2hp, 3ph, 460V " " "			
12	Pulley, 2-3/4" x 7/8", "A"	1	J0295	J0295
	*Pulley, 3" x 7/8", "A" groove	1	J0319	J0319
13	Key, 3/16" x 3/16" x 3/4"	1	A7522	A7522
14	Shoulder bolt, 5/16", 3/4", 1/4 - 20 thread	2	J0521	J0521
15	Outer carriage shield	1	A8508	A6120
16	Plastic cord holder	1	A5637	A5637
17	Machine screw #10 - 24	1	J0514	J0514
18	Nut, #10 - 24	1	J0985	J0985
19	Tilt switch bracket		A5449	A5449
20	Tilt switch, 7MPL-46		A5445	A5445
21	Tilt switch bracket & cord (Not shown)		Varies by unit. See Page 75.	
22	Down auger 15' 6" standard (Other sizes optional)	1	A4210	A4210
23	Flinger	1	A5616	A5616
24	Flange bearing, 1"	2	J0003	J0003
25	Locking collar	2	J0067	J0067
26	Bolt, 7/16" - 14 x 1-1/2"	4	J0710	J0710
27	Nut, 7/16" - 14	4	J1035	J1035
28	Lock washer, 7/16"	4	J1210	J1210
29	U-bolt, 5/16" - 18 x 1-3/4"	1	J0810	J0810
30	Pulley, 9", "A" groove, w/ pin hole	1	J0355	J0355
31	Rollpin, 5/16" x 2-1/4"	1	J1510	J1510
32	Belt	1	J0179	J0195
33	Tie bar (Specify size needed)		Varies by unit. See Page 16.	
35	Reversing rod bolt	1	A8550	A8550
36	Decal, Warning	1	L0284	L0284
37	Decal, Replace Shield	1	L0271	L0271
38	Outer slug w/ drive wheel	1	A8085	A8089
39	Lock nut, 1/4 - 20	2	J0992	J0992
40	Toggle arm	1	A8505	A8505
41	Carriage bolt	4	J07592	J07611
42	Nut, 1/2"	12	J1040	J1040
43	Reversing rod	1	Varies. See Page 16.	
44	Bolt, 1/4" x 1"	4	J0508	J0508
46	Lock washer, 1/2"	3	J1215	J1215
47	Push nut, 7/16"	2	J1036	J1036
48	Bearing block (Not shown)	2	A8507	A8507
48A	Bearing ball transfer (Not shown)	1	J0144	J0144
49	Screws, #8, stainless steel (Not shown)	4	J0463	J0463
50	Cord support strap	1	A6121	A6121
51	Shoulder bolt, 8 mm, 10, 6 mm thread	1	J0538	J0538
52	Lock nut, 6 mm	1	J0998	J0998

* For required receptacle, see Page 67.

STATIONARY OUTSIDE CARRIAGE (FASTIR-PLUS ONLY)

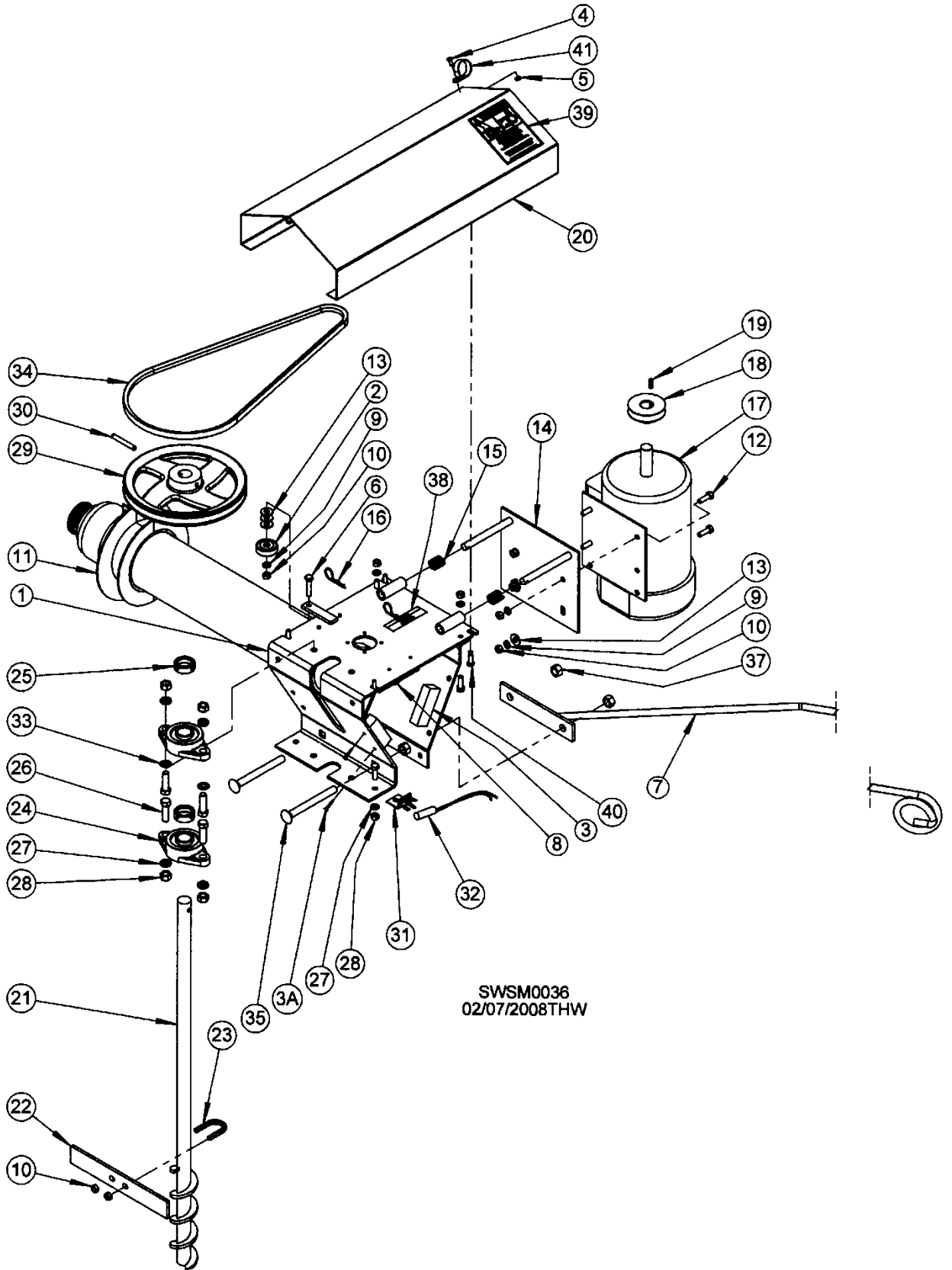

STATIONARY OUTSIDE CARRIAGE PARTS LIST (FASTIR-PLUS ONLY)

Ref. #	Description	Qty.	Part #	Part #
			4-1/2" Crosstube	5-1/2" Crosstube
1	Outside carriage	1	A5250	A6140
2	Roller bearing	1	J0045	J0045
3	Bearing block	4	A8507	A8507
3A	Screws, 1-1/8"	8	J0463	J0463
4	Machine screw, #10 – 24	1	J0514	J0514
5	Nut, #10 – 24	1	J0985	J0985
6	Bolt, 5/16" x 1-1/4"	1	J0550	J0550
7	Cord hanger	1	A52121	A52121
8	Bearing, 1" OD, 5/16" ID	2	J00425	J00425
9	Lock washer, 5/16"	8	J1200	J1200
10	Nut, 5/16"- 18	11	J1002	J1002
11	Stationary carriage guide/plate	1	A5245	A6115
12	Screw, 5/16" - 18 x 1"	7	J0527	J0527
13	Flat washer, 5/16"	6	J1111	J1111
14	Motor mount	1	A5209	A5209
15	Compression spring, 1-1/2" x 1/2" ID	2	J2365	J2365
16	Hairpin clip	2	J5410	J5410
17*	Motor, "O", 1-1/2hp, 230V, 1ph (Includes pulley & key)	1	A7725	A7725
	Motor, "O", 1-1/2hp, 230V, 3ph (Includes pulley & key)	1	A7729	A7729
18	Pulley, 2-3/4" x 7/8, "A"	1	J0295	J0295
19	Key, 3/16" sq. x 3/4"	1	A7522	A7522
20	End carriage shield	1	A8508	A6120
21	Down auger, 15' 6" standard (Other sizes optional)	1	A4210	A4210
22	Flinger	1	A5616	A5616
23	U-bolt, 5/16- 18 x 1-3/4"	1	J0810	J0810
24	Flange bearing, 1"	2	J0003	J0003
25	Locking collar	2	J0067	J0067
26	Bolt, 7/16"- 14 x 1-1/2"	4	J0710	J0710
27	Lock washer, 7/16"	4	J1210	J1210
28	Nut, 7/16"- 14	4	J1035	J1035
29	Pulley, 9", "A" groove, w/ pin hole	1	J0355	J0355
30	Rollpin 5/16" x 2-1/4"	1	J1510	J1510
31	Tilt switch brkt. w/ clip	1	A5449	A5449
32	Tilt switch, 7MP 1-46	1	A5445	A5445
	Tilt switch brkt. & cord (Not shown)	1	Varies. See Page 75.	
33	Push nut, 7/16"	2	J1036	J1036
34	Belt	1	J0179	J0195
35	Carriage bolt,	2	J07601	J07611
37	Nut, 1/2" – 13	6	J1040	J1040
38	Decal, Warning	1	L0284	L0284
39	Decal, Replace Shield	1	L0271	L0271
40	Bolt, 1/4" - 20 x 3/4"	2	J0505	J0505
41	Plastic cord holder	1	A5637	A5637

*Part numbers shown are for Leeson motors. Add "B" to end of part number for Baldor motor.

ELECTRICAL JUNCTION BOX

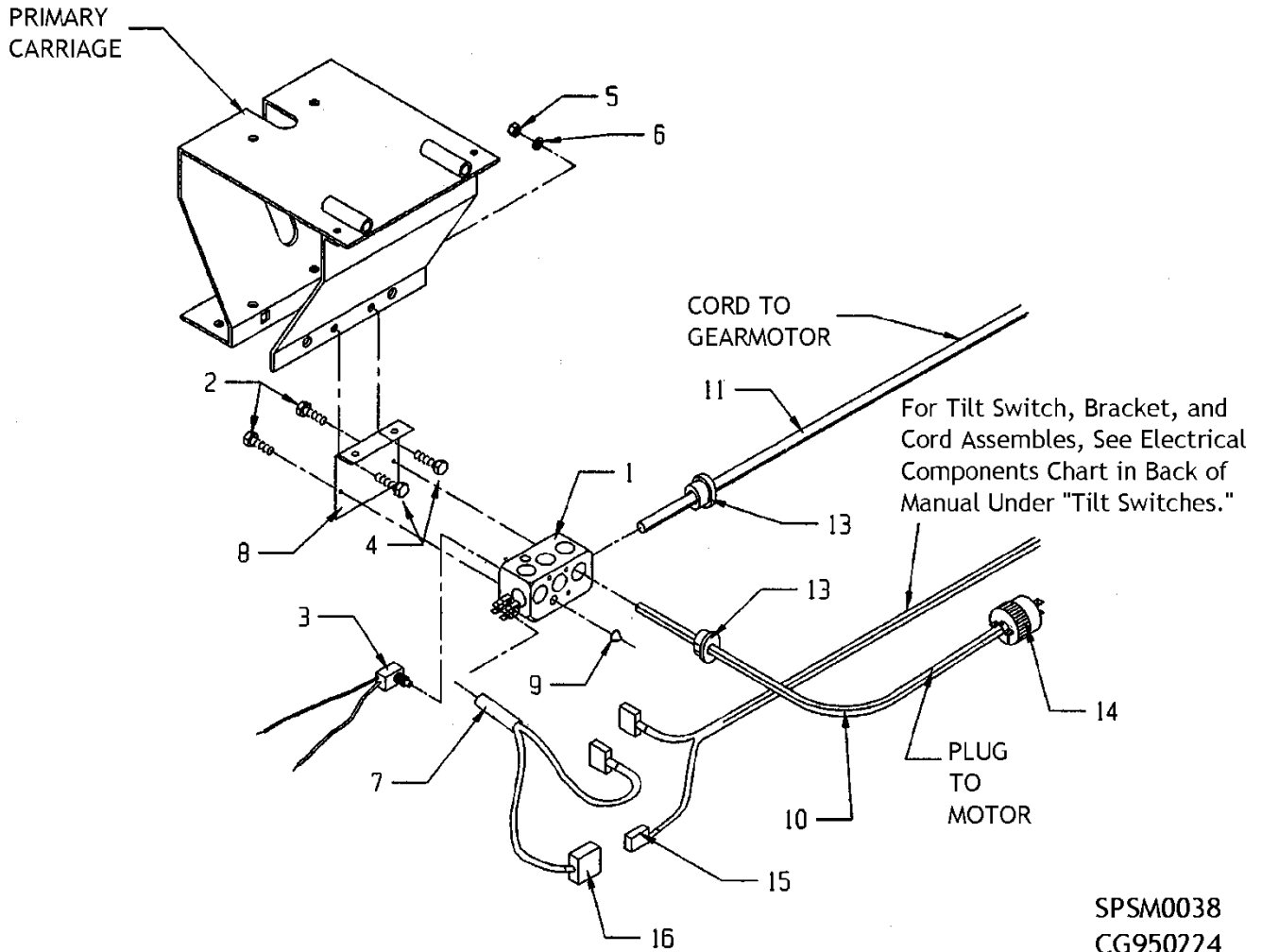

SPSM0038
CG950224

Ref. #	Description	Qty.	Part #
	Junction switch box, w/ 15' 4" cord & mount		A8140
	Junction switch box, w/ 17' 10" cord & mount		A8141
	Junction switch box, w/ 20' 4" cord & mount		A8142
	Junction switch box, w/ 22' 4" cord & mount		A8143
1	Electric box	1	A8139
2	Screw #6 - 32 x 1/4"	2	J0455
3	Push button (normally open)	1	J4485
4	Bolt, 5/16 - 18 x 1"	2	J0527
5	Nut, 5/16" - 18	2	J1002
6	Lock washer, 5/16"	2	J1200
7	Tilt switch w/connector	1-5	A5445
8	Electric box mounting plate	1	A8081
9	Push-button switch cover	1	J4500
10	Power cord (18-3) 16" w/ plug	1	A5350
11	*Gearmotor cord only 18-3	1	K6551
13	Bushing, 7-K-2	2	J5040
14	Plug, 3-prong male	1	J3715
15	Female spade, 4 x 293		J3826
16	Male spade, 4 x 292		J3822

* When ordering this part, machine size, number of down auger, and/or cord lengths must be specified to match proper parts.

ROTATING CONTACT

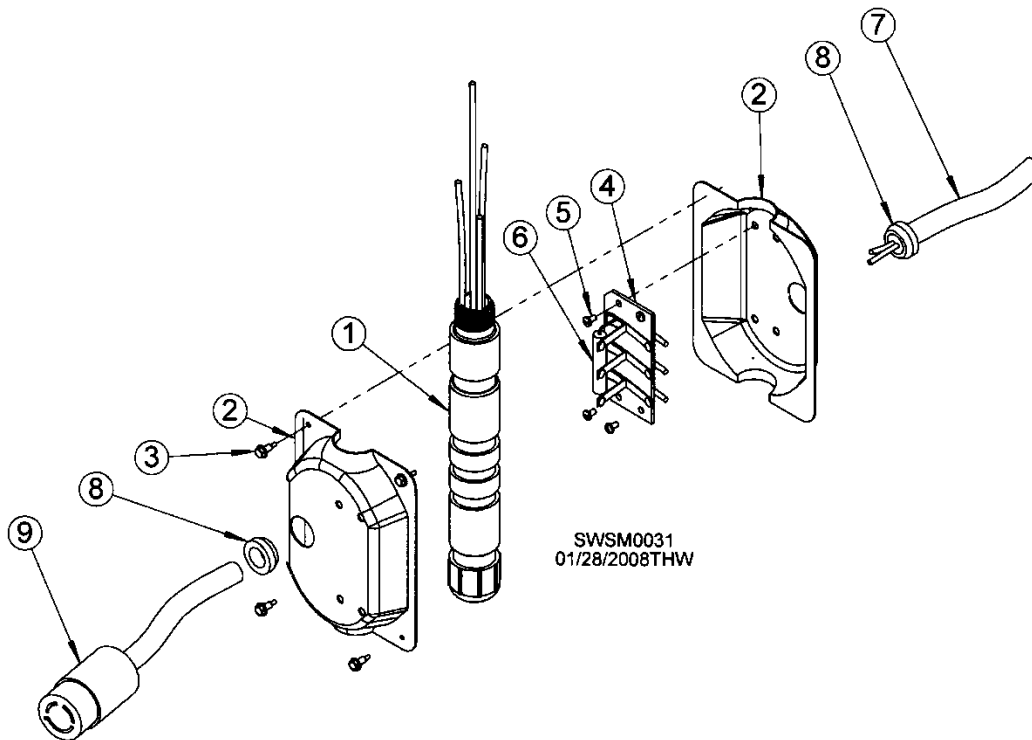

Ref. #	Description	Qty.	Part #	The following are complete rotating contacts with cords. Listed are standard replacement cord lengths. If different length is required, specify desired length when ordering. See table on next page.					
1	Rotating contact, 3-wire, 1ph	1	A5558	Part #	Volts	# of Leads	Phase	Spool Wire	Cord Length
	Rotating contact, 4-wire, 3ph		A5559	230	Single	1	3	17'10"	
	Rotating contact, 5-wire, 1ph		A5585	230	Single	3	4	17'10"	
	Rotating contact, 7-wire, 3ph		A5560	460	Single	3	4	19'2"	
	Rotating contact can, single		A5549	230	Dual	1	5	12'10", 10'10"	
2	Can, lead side only	1	A5594	A5475	230	Dual	1	5	12'10", 10'10"
	Can, side only, single		A5595	A5476	230	Dual	1	5	15'10", 10'10"
	Rotating contact can, dual		A5550	A5477	230	Dual	1	5	17'10", 10'10"
	Can, lead side only		A5594	A5478	230	Dual	1	5	24'10", 10'10"
	Can, side only, dual		A5596	A5480	230	Dual	3	7	12'10", 10'10"
			A5596	A5481	230	Dual	3	7	15'10", 10'10"
			A5596	A5482	230	Dual	3	7	17'10", 10'10"
	A5596	A5483	230	Dual	3	7	24'10", 10'10"		
3	Screw, #8 - 18 x 1/2", self-drill	4	J0460	The following are rotating contacts without cord:					
4	Cont. bd, 1ph, w/ htr, 3-terminal	1*+	A5563	A5551	230	Single	1	3	N/A
	Cont. bd, 1ph, w/o htr, 3-terminal		A5578	A5553	230	Single	3	4	N/A
	Cont. bd, 3ph, w/ htr, 3-terminal		A5561	A5554	460	Single	3	4	N/A
	Cont. bd, 3ph, w/o htr, 3-terminal		A5580	A5555	230	Dual	1	5	N/A
5	Cont. bd, 460V, 3ph w/ htr, 3-terminal	4*	A5582	A5556	460	Dual	3	7	N/A
6	Pan-head machine screw 1/4"	1	J0455	A5557	230	Dual	3	7	N/A
	Contact board heater, 230V		J5530						
7	Contact board heater, 460V	1*	J5532						
	Cord, 12-3, (specify lgth req.)		K6331						
8	Cord, 14-4, (specify lgth req.)	1*	K6401	Note: Can should be sealed with tub and tile caulk. Spool should spin freely after assembly. If spool binds, find and correct problem before installing on stirring machine.					
9	Bushing, 8P-2	1*	J5000						
9	3-prong female plug	1*	J3720						
	4-prong female plug, 460V, wired direct		J3730						

*Number required for single lead rotating contact. Qty. required for dual lead rotating contact is double.

+Single lead contacts require 1 board w/ heater. Dual lead contacts require 1 board w/ heater, 1 without.

CORD LENGTHS FOR FASTIR & FASTIR PLUS

Bin Dia	A Motor Cord	B Motor Cord	S Motor Cord	O Motor Cord	Tilt Switch Quantity	Tilt Switch Cord Length	Rotating Contact	Dual Lead Rotating Contact	Gearmotor Cord
Single									
18'	-	-	1	-	-	-	12' 10"	-	17' 10"
21'	-	-	1	-	-	-	12' 10"	-	17' 10"
24'	-	-	1	-	-	-	14' 6"	-	20' 4"
27'	-	-	1	-	-	-	17' 10"	-	20' 4"
30'	-	-	1	-	-	-	17' 10"	-	22' 4"
31'	-	-	1	-	-	-	17' 10"	-	22' 4"
Double									
18'	5'	-	-	1	1	4'	10' 10"	-	15' 4"
21'	6'	-	-	1	1	5'	10' 10"	-	15' 4"
24'	6'	-	-	1	1	5'	10' 10"	-	15' 4"
27'	7'	-	-	1	1	6'	10' 10"	-	15' 4"
30'	8'	-	-	1	1	7'	10' 10"	-	15' 4"
31'	8'	-	-	1	1	7'	10' 10"	-	15' 4"
33'	8'	-	-	1	1	8'	12' 10"	-	17' 10"
36'	9' 6"	-	-	1	1	8'	12' 10"	-	17' 10"
Triple - Fastir <i>Note: On Triple, 1 phase units, use dual rotating contact with "A", dual "O" motors. For sizes not listed, check nearest size. For example, on 37' 1", use lengths for 36'.</i>									
18'	4'	3' - 3PH	-	1 - 3PH 2 - 1PH	2	3'	10' 10"	12' 10" 1PH	15' 4"
21'	5'	3' - 3PH	-	1 - 3PH 2 - 1PH	1	3'	10' 10"	15' 10" 1PH	15' 4"
24'	6'	3' - 3PH	-	1 - 3PH 2 - 1PH	1	3'	10' 10"	15' 10" 1PH	15' 4"
27'	6'	3' - 3PH	-	1 - 3PH 2 - 1PH	1	3'	10' 10"	17' 10" 1PH	15' 4"
30'	7'	3' - 3PH	-	1 - 3PH 2 - 1PH	1	3'	10' 10"	20' 10" 1PH	15' 4"
31'	7'	3' - 3PH	-	1 - 3PH 2 - 1PH	1	3'	10' 10"	20' 10" 1PH	15' 4"
33'	8'	3' - 3PH	-	1 - 3PH 2 - 1PH	1	3'	12' 10"	22' 10" 1PH	15' 4"
36'	8'	3' - 3PH	-	1 - 3PH 2 - 1PH	1	3'	12' 10"	22' 10" 1PH	15' 4"
42'	9' 6"	4' - 3PH	-	1 - 3PH 2 - 1PH	1	3'	14' 6"	28' 4" 1PH	20' 4"
48'	11'	4' - 3PH	-	1 - 3PH 2 - 1PH	1	3' 9' 6"	17' 10"	29' 6" 1PH	20' 4"
Triple - Fastir Plus									
18'	5'	7' - 3PH	-	1 - 3PH 2 - 1PH	1	9' 6" 3'	10' 10"	12' 10" 1PH	15' 4"
21'	6'	7' - 3PH	-	1 - 3PH 2 - 1PH	1	9' 6" 4'	10' 10"	15' 10" 1PH	15' 4"
24'	7'	8' - 3PH	-	1 - 3PH 2 - 1PH	1	11' 4'	10' 10"	15' 10" 1PH	15' 4"
27'	8'	9' 6" - 3PH	-	1 - 3PH 2 - 1PH	1	11' 5'	10' 10"	17' 10" 1PH	17' 10"
30'	8'	9' 6" - 3PH	-	1 - 3PH 2 - 1PH	1	11' 6'	12' 10"	20' 10" 1PH	17' 10"
31'	8'	9' 6" - 3PH	-	1 - 3PH 2 - 1PH	1	11' 6'	12' 10"	20' 10" 1PH	17' 10"
33'	9' 6"	11' - 3PH	-	1 - 3PH 2 - 1PH	1	7' 13'	12' 10"	22' 10" 1PH	17' 10"
36'	9' 6"	11' - 3PH	-	1 - 3PH 2 - 1PH	1	7' 13'	12' 10"	22' 10" 1PH	17' 10"
Quad - Fastir Plus									
27' *	5'	9' 6"	-	2	1 1 1	11' 3' 4'	10' 10"	20' 10"	15' 4"
30' *	6'	9' 6"	-	2	1 1 1	3' 5' 11'	10' 10"	20' 10"	15' 4"
31' *	6'	9' 6"	-	2	1 1 1	3' 5' 11'	10' 10"	20' 10"	15' 4"
33' *	7'	11'	-	2	1 1 1	3' 6' 11'	12' 10"	24' 10"	17' 10"
36' *	7'	11'	-	2	1 1 1	3' 7' 12'	12' 10"	24' 10"	17' 10"
42' *	9' 6"	11'	-	2	1 1 1	4' 8' 12'	12' 10"	28' 4"	17' 10"
Quint - Fastir Plus									
42' *	7'	9' 6" 7'	-	2	1 1 1 1	5' 4' 6' 11'	12' 10"	28' 4"	15' 4"
48' *	8'	7' 8'	-	2	1 2 1	4' 7' 11'	12' 10"	28' 4"	17' 10"

ELECTRICAL COMPONENTS FOR FASTIR & FASTIR PLUS

Bin Diameter	1 PH, 230V						3 PH, 230V						3 PH, 460V						Fastir Plus	
	S Motor	O Motor	A Motor	B Motor	Rotating Contact		S Motor	O Motor	A Motor	B Motor	Rotating Contact		S Motor	O Motor	A Motor	B Motor	Rotating Contact	Tilt Switch	Tilt Switch	
Single																				
18-187"	A7720	-	-	-	A5502	A7730	-	-	-	A5530	A7734	-	-	-	-	-	A5537	-	-	
21-218"	A7720	-	-	-	A5502	A7730	-	-	-	A5530	A7734	-	-	-	-	-	A5537	-	-	
24-248"	A7720	-	-	-	A5503	A7730	-	-	-	A5531	A7734	-	-	-	-	-	A5538	-	-	
27-2710"	A7720	-	-	-	A5504	A7730	-	-	-	A5532	A7734	-	-	-	-	-	A5539	-	-	
30-31"	A7720	-	-	-	A5504	A7730	-	-	-	A5532	A7734	-	-	-	-	-	A5539	-	-	
33-34"	A7720	-	-	-	A5502	A7732	-	-	-	A5530	A7734	-	-	-	-	-	A5537	-	-	
36-371"	A7720	-	-	-	A5502	A7732	-	-	-	A5530	A7734	-	-	-	-	-	A5537	-	-	
Double																				
18-187"	-	A7725	A77215	-	A5501	-	A7729	A77325	-	A5529	-	A7733	-	A7735	-	-	A5536	A8431	-	
21-218"	-	A7725	A77216	-	A5501	-	A7729	A77326	-	A5529	-	A7733	-	A7735	-	-	A5536	A8432	-	
24-248"	-	A7725	A77216	-	A5501	-	A7729	A77326	-	A5529	-	A7733	-	A7735	-	-	A5536	A8432	-	
27-2710"	-	A7725	A77217	-	A5501	-	A7729	A77327	-	A5529	-	A7733	-	A7735	-	-	A5536	A8433	-	
30-31"	-	A7725	A77216	-	A5501	-	A7729	A77328	-	A5529	-	A7733	-	A7735	-	-	A5536	A8434	-	
33-34"	-	A7725	A77216	-	A5502	-	A7729	A77328	-	A5530	-	A7733	-	A7735	-	-	A5537	A8434	-	
36-371"	-	A7725	A7721	-	A5502	-	A7729	A7732	-	A5530	-	A7733	-	A7735	-	-	A5537	A8435	-	
Triple-Fastir & Fastir Plus Note: * Denotes component is required for Fastir Plus instead of alternative.																				
18-187"	-	A7725 x2	A77214	-	A5475	-	A7729	A77324	A77313	A5529	-	A7733	-	A7735	-	-	A5536	A8430 x2	A8430	
21-218"	-	A7725 x2	A77215*	-	A5476	-	A7729	A77325	A77313	A5529	-	A7733	-	A7735	-	-	A5536	A8430	A8431	
24-248"	-	A7725 x2	A77216*	-	A5476	-	A7729	A77326	A77313	A5529	-	A7733	-	A7735	-	-	A5536	A8430	A8431	
27-2710"	-	A7725 x2	A77217*	-	A5477	-	A7729	A77327	A77313	A5529	-	A7733	-	A7735	-	-	A5536	A8432	A8437	
30-31"	-	A7725 x2	A77218*	-	A5519	-	A7729	A77328	A77313	A5529	-	A7733	-	A7735	-	-	A5536	A8430	A8433	
33-34"	-	A7725 x2	A77218*	-	A5507	-	A7729	A77328	A77313	A5530	-	A7733	-	A7735	-	-	A5537	A8430	A8434	
36-371"	-	A7725 x2	A77218*	-	A5507	-	A7729	A77328	A77313	A5530	-	A7733	-	A7735	-	-	A5537	A8430	A8434	
42"	-	A7725 x2	A7721	-	A5511	-	A7729	A77329	A77314	A5531	-	A7733	-	A7735	-	-	A5538	A8430	A8439	
48"	-	A7725 x2	A77219	-	A5512	-	A7729	A77329	A77314	A55321	-	A7733	-	A7735	-	-	A55381	A8430	A8439	
Quad-Fastir Plus																				
27-2710"	-	A7725 x2	A77215	A7728	A5519	-	A7729 x2	A77325	A7731	A5481	-	A7733 x2	A7735	A7736	A7735	A7736	A55481	-	A8430	
30-31"	-	A7725 x2	A77216	A7728	A5519	-	A7729 x2	A77326	A7731	A5481	-	A7733 x2	A7735	A7736	A7735	A7736	A5547	-	A8430	
33-34"	-	A7725 x2	A77217	A77289	A55071	-	A7729 x2	A77327	A77319	A55901	-	A7733 x2	A7735	A7736	A7735	A7736	A55484	-	A8430	
36-371"	-	A7725 x2	A77217	A77289	A55071	-	A7729 x2	A77328	A77319	A55901	-	A7733 x2	A7735	A7736	A7735	A7736	A55484	-	A8430	
42-428"	-	A7725 x2	A7721	A77289	A5484	-	A7729 x2	A7732	A77319	A5485	-	A7733 x2	A7735	A7736	A7735	A7736	A55486	-	A8430	
Quint-Fastir Plus																				
42-428"	-	A7725 x2	A77217	A77287	A5484	-	A7729 x2	A77326	A77317	A5485	-	A7733 x2	A7735	A7736 x2	A7735	A7736 x2	A55486	-	A8431	
48"	-	A7725 x2	A77216	A77288	A5484	-	A7729 x2	A77327	A77318	A5485	-	A7736 x2	A7735	A7736 x2	A7735	A7736 x2	A55486	-	A8431	

Motor part numbers shown are for Leeson motors. Add "B" to end of part number for Baldor motor.

CONTACT INFORMATION

Sukup Dealer Information

Dealer name:	_____
Address:	_____
Cell phone:	_____
Office phone:	_____
Fax:	_____

In Case of Emergency

Have emergency numbers and written directions to your location near a phone.
Arrange and practice a safety plan.

Ambulance • Fire • Police: 9-1-1	
Bin rescue team:	_____
Local EMS team:	_____
911 Address of work site:	_____
Directions to work site:	_____

PRODUCT WARRANTY REGISTRATION

Please scan QR code or follow the link
<https://www.sukup.com/resources/warranty-registration>
to register online.



Sukup Manufacturing Co.

1555 255th Street, Box 677

Sheffield, Iowa, USA 50475-0677

Phone: 641-892-4222

Fax: 641-892-4629

Website: www.sukup.com

Email: info@sukup.com