



STIFFENED BIN CONSTRUCTION MANUAL

Farm Stiffened, 15' - 48' Dia., 5K Roof

Roof rating is based on weight evenly distributed on peak ring as pure vertical load with uniformly distributed roof snow load calculated from 40psf ground snow zone or 105 mph wind zone as defined by ASCE 7-10 Code.



| <u>DATES</u> | <u>REVISIONS</u> | <u>SECTION</u> |
|--------------|---------------------------------------------------------------------------------------|----------------|
| 12/2018 | Updated sidewall bolt usage instructions | Roof, Sidewall |
| 03/2018 | Updated internal roof ring components table..... | Roof |
| | Added notice & drawing on proper way to tighten bin bolts..... | Sidewall |
| | Added corner splicing instructions for 44" doors & parts breakdown for 66" doors..... | Doors |
| | Updated drawings, part numbers & instructions throughout..... | Ladders |

Sukup Manufacturing Co.

1555 255th Street, Box 677

Sheffield, Iowa, USA 50475-0677

Phone: 641-892-4222

Fax: 641-892-4629

Website: www.sukup.com

E-mail: info@sukup.com

IMPORTANT: KEEP GALVANIZED SHEETS DRY BEFORE ERECTING!

If this material is allowed to get wet or condensation is permitted to form between sheets, discoloration may occur.

- Upon receiving material, check for moisture between sheets. Do not permit moisture from weather, condensation or other sources to remain between sheets.
- To help prevent white rust, store sheets away from moisture. Store under cover in a heated building with adequate air circulation if lengthy storage or adverse weather conditions are expected. Never allow water to stand on sheets or bundles.
- Sheets covered with tarpaulin or polyethylene should have enough space between cover and sheets to allow air to circulate.
- If bundle gets wet, dry all materials immediately. Stack sheets on edge in a dry place and force air between them. Allow for free passage of air around each sheet when practical.
- NEVER lay steel on earth. Store on timber or blocks. Always store material on a dry, solid surface in a manner that allows moisture to run off of material.
- DO NOT apply any solvents or lubricants to sidewall sheets.

Damage resulting from failure to take appropriate actions listed above will void Sukup Manufacturing Co. warranty.

IMPORTANT: Sukup Manufacturing Co. must be notified within 72 hours of pickup or delivery if any materials are rusted. Sukup is not responsible for rusted materials discovered after the 72-hour period. Sukup accepts no responsibility for stains, corrosion or other damage to sheets while stored at construction site.



Sukup Manufacturing Co.

PO Box 677 Sheffield, IA USA 50475

Phone: 641-892-4222 Fax: 641-892-4629

E-mail: Info@sukup.com Visit us at: www.sukup.com

GRAIN BIN LIMITED WARRANTY

SUKUP MANUFACTURING CO. (Sukup) warrants, to original retail purchaser within 5 years from date of purchase, that grain bin shall be free from defects in material and workmanship. A part will not be considered defective if it substantially fulfills performance specifications, such as cosmetic (appearance) issues that will not affect life of the structure. Should any part prove defective within warranty period, part will be replaced without charge F.O.B. Sukup Manufacturing Co., Sheffield, Iowa USA or Distribution Centers - Arcola, Illinois; Aurora, Nebraska; Defiance, Ohio; Jonesboro, Arkansas; Cameron, Missouri; Watertown, South Dakota. To obtain warranty, a copy of original invoice is required.

WARRANTY CERTIFICATION - Warranty registration card should be mailed within two weeks of product delivery to certify warranty coverage.

THE FOREGOING LIMITED WARRANTY IS EXCLUSIVE AND IN LIEU OF ALL OTHER WARRANTIES OF MERCHANTABILITY, FITNESS FOR PARTICULAR PURPOSE AND OF ANY OTHER TYPE, WHETHER EXPRESS OR IMPLIED. Sukup neither assumes nor authorizes anyone to assume for it any other obligation or liability in connection with said part, and will not be liable for incidental or consequential damages. REMEDIES STATED HEREIN SHALL BE THE EXCLUSIVE REMEDIES AVAILABLE UNDER THIS LIMITED WARRANTY.

Sukup reserves the right to change specifications, add improvements or discontinue manufacture of any of its equipment without notice or obligation to purchasers of its equipment. This warranty gives you specific legal rights. You may also have other rights which vary according to state or province.

WARRANTY EXCLUSIONS - Labor, transportation, or any cost related to a service call is not provided by Sukup. This Limited Warranty does not apply to damage resulting from misuse, neglect, normal wear, accident or improper installation or maintenance. ITEMS NOT MANUFACTURED BY SUKUP ARE COVERED UNDER WARRANTIES OF THEIR RESPECTIVE MANUFACTURERS AND ARE EXCLUDED FROM COVERAGE UNDER THE SUKUP WARRANTY. SUKUP MANUFACTURING CO. MAKES NO WARRANTY, EXPRESS OR IMPLIED, OF MERCHANTABILITY OR FITNESS FOR A PARTICULAR PURPOSE.

Foundation recommendations are suggestions only and will vary according to local soil conditions. Soil bearing tests must be performed by a competent, independent engineering firm. Sukup will not assume responsibility for adverse result arising from their use. Sukup will not warrant damage or loss caused, in whole or in part, by inadequate or improper site selection, site preparation, foundation, or any other failure to provide a suitable erection or installation environment for Sukup grain bin or of any product, component, equipment, accessories, parts used in conjunction with Sukup grain bin. Sukup will not warrant damage or loss caused, in whole or in part, by use of bin in a manner other than for which it was designed, or by unauthorized attachments, modifications, alterations, improper or inadequate maintenance, misuse or abuse of the bin.

Sukup is not liable for direct, indirect, incidental or consequential damages, including, without limitation, loss of anticipated profits or benefits. Not responsible for field modifications or erection defects which create structural or storage quality problems.

WARRANTY IS VOID - If not purchased from or constructed by an authorized dealer or a representative of Sukup Manufacturing Co.; If used for substances other than grains and/or free flowing materials.

Prior to installation, purchaser has responsibility to properly store steel bin components. Bin should be stored in dry, temperature and humidity controlled areas to eliminate condensation and other moisture that causes white rust and corrosion. Warranty does not extend to defects, damages or cosmetic (appearance) issues caused by improper storage or handling.

Sukup does not warrant any roof damage caused by excessive vacuum or internal pressure from fans or other air moving systems. Adequate ventilation and/or "make-up air" devices should be provided for all powered air handling systems. Warranty is void if grain is above eave and against roof, as this will block roof vents and cause unwanted loads on roof sheets. Area above surface of grain must allow free movement of air to vents. Sukup does not recommend use of downward flow systems (suction). Severe structural roof damage may occur if fans or other air moving devices are operated during certain high humidity/cold weather conditions. Roof ventilators may frost over and plug or restrict air flow causing excessive vacuum or internal pressures. Roof damage may occur due to improperly installed grain temperature detection cable systems.

Sukup does not warrant failures due to filling bin off-center; unloading from door or off-center floor sump; or radial cracks in foundation. If bin has a perforated floor on columns and columns fail, bin can shift sideways causing both sidewall and roof damage.

UNAPPROVED PARTS OR MODIFICATION - All obligations of Sukup under this warranty are terminated if unapproved parts are used, equipment is modified or altered in any way not approved by Sukup in writing, or is not erected or operated according to Sukup installation or operating manuals.

Table of Contents

| | |
|------------------------------------------|---------|
| Important Message | 2 |
| Limited Warranty | 3 |
| Safety Section | 5-15 |
| Bin Operation & Management | 16-32 |
| Foundation & Anchor Locations | 33-49 |
| Farm Anchors | 50-51 |
| 5K Roof Assembly | 52-71 |
| Farm Stiffened Sidewall | 72-80 |
| Wind Ring | 81-82 |
| Farm Door | 83-87 |
| Ladders, Safety Cages & Platforms | 88-120 |
| Greene Sidewall / Easy Step Stairs | 121-136 |

IMPORTANT

Please read entire Bin Operation Manual and Construction Manual, paying close attention to safety sections. Failure to read these manuals is a misuse of the product and could result in death or personal injury or property damage. All personnel associated with the bin must read these manuals thoroughly as well.

Although every effort is made to ensure assembly drawings and instructions are written without errors, they may happen. Therefore, if any concerns arise regarding any instructions or assembly drawings, please contact Sukup Manufacturing Co. customer service immediately for clarification prior to proceeding with construction.

Recognizing Safety Decal Information

 Read manual before installing or using product. Failure to follow instructions and safety precautions in manual can result in death or serious injury. Keep manual in a safe location for future reference.



On safety decals, this symbol and the signal words Danger, Warning, Caution and Notice draw your attention to important instructions regarding safety. They indicate potential hazards and levels of intensity.



RED - **DANGER** indicates an imminently hazardous situation which, if not avoided, will result in death or serious injury.



ORANGE - **WARNING** indicates a potentially hazardous situation which, if not avoided, could result in death or serious injury.



YELLOW - **CAUTION** indicates a potentially hazardous situation which, if not avoided, may result in minor or moderate injury.



BLUE - **NOTICE** alerts you to practices unrelated to personal injury, such as messages related to property damage.

IMPORTANT: To prevent serious injury or death to you or your family, be certain that all decals are in place according to illustration below and are legible. If a suggested location is not clearly visible, place decal in a more suitable area. Additional safety decals are available at no charge for Sukup equipment. Please specify decal number when ordering. See contact information on cover of manual.

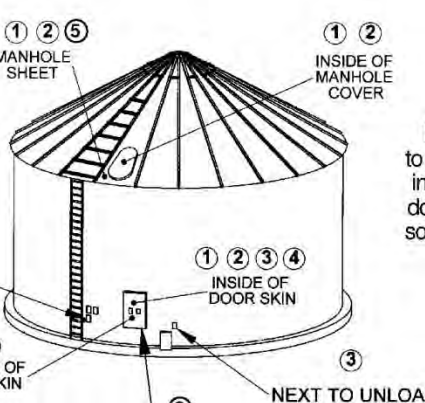

1 LADDER WARNING - Decal L0164
Mount on bin sheet next to ladder or stairs. Attached in advance on inside bin door and on manhole sheet so it can be seen by anyone entering bin.

2 "DANGER DO NOT ENTER" - Decal L0258A
Mount on bin sheet next to ladder or stairs. Attached in advance on inside of bin door and on manhole sheet so it can be seen by anyone entering bin.

3 "WARNING DO NOT ENTER this bin! Keep clear of all augers."
Failure to heed these warnings will result in serious injury or death.

4 "WARNING TO AVOID SERIOUS INJURY" - Decal L0281
Mount decal on bin sheet next to ladder or stairs. Attached in advance on inside of bin door so it can be seen by anyone entering bin.

5 "WARNING DO NOT OVERFILL BIN" - Decal L0906
Attached in advance on manhole sheet so it can be seen by anyone entering bin.

6 "WARNING CLOSE DOOR TIGHTLY..." - Decal L0909
Attached in advance on outside of inner door panel.

6 "WARNING OFF-CENTER UNLOADING" - Decal L0269
Mount on outside of bin next to unload so it can be seen by person unloading bin. Attached in advance on inside of bin door.

6 "WARNING CLOSE DOOR TIGHTLY..." - Decal L0909
Attached in advance on outside of inner door panel.

General Operational Safety Procedures



WARNING: Make hazards known to all personnel working in area so they can take appropriate safety precautions. Failure to follow precautions listed below may cause death or serious injury.

- Hands, feet and clothing must be kept away from moving parts. Loose clothing can become entangled in moving parts and cause serious injury.
- Be aware of danger that is present when loading and unloading bin. Flowing and crusted grain can trap and suffocate.
- Do not enter bin without having an observer outside who is in constant contact with you.
- Decals with specific messages are attached to equipment at various locations. Pay attention to messages and always be alert to the possibility of personal injury or death.
- Keep all guards and shields in place and secure while machines are in operation.
- Ladders and working surfaces should have safety cages and handrails for safe use. Use a lifeline and harness when danger of falling exists.
- Keep bystanders and children away from grain bins and grain handling equipment. **Bin sites are not playgrounds!**
- Bins must be labeled to warn of entrapment and flowing grain hazards.
- Proper operational procedures must be followed to ensure safety and well-being of all persons working near or on grain bins when inspecting grain, performing maintenance or spraying insecticides.
- Hazards associated with grain bins include engulfment in grain, falls from heights, dust and mold inhalation, pesticide exposure, electrocution, and injuries from augers. Take precautionary steps to avoid these hazards.
- Learn how to use controls and operate equipment correctly. Do not let anyone operate unit (especially youth) without thorough training of basic operating and safety procedures.
- Periodically check all mechanical and electrical components to keep them in good working condition. Make no unauthorized modifications to equipment. Doing so may endanger function and safety of unit.
- Be aware of weather-related safety hazards. Icicles and snow falling from bin eave are dangerous and can cause serious injury or death. Ice or moisture on ladders can cause slippery conditions that may result in a life-threatening fall.
- For added security and safety, attach a padlock to sidewall door latch.
- If you must enter bin, shut off equipment and lock out all power sources before entering; keep clear of all moving parts; use a safety harness and safety line, station another person outside of bin; avoid center of bin; wear proper breathing equipment or respirator; follow applicable safety regulations; ensure quick access to an ABC dry chemical fire extinguisher.

Dangers of Entering a Grain Bin



No one should enter a grain bin while it is being loaded or unloaded due to risk of being injured by moving parts such as augers or being crushed and/or suffocated by grain. Entering a bin that has bridged or crusted grain is very dangerous. Working in a grain bin without following proper safety procedures increases an individual's chance of being suffocated. If stored grain is peaked close to roof, be extremely cautious. Crawling between roof and peak could cave grain and block exit.

Owners/operators are responsible for developing site-specific confined space entry procedures. OSHA's confined space entry procedures (29CFR 1910.146) can be found at www.osha.gov.

Flowing & Crusted Grain

People can become caught or trapped by grain in several ways: entrapment by flowing grain, collapse of bridged grain, and collapse of a vertical wall of grain. To better understand why grain flow is so dangerous, you must understand how grain flows when it is unloaded. Grain bins are first emptied through the center sump (bins erected with a sidedraw are only exception). When center sump is opened and auger is started, grain flows from top surface down a center core to center sump. This is called funnel flow and is illustrated in figures below.

Based on 8" unload auger

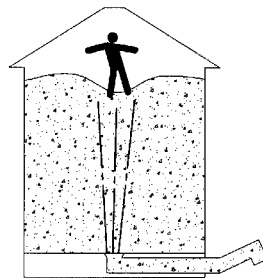

2 seconds

From time auger starts, you have 2 seconds to react.

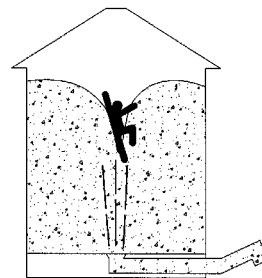

4 seconds

In 4 seconds you are trapped

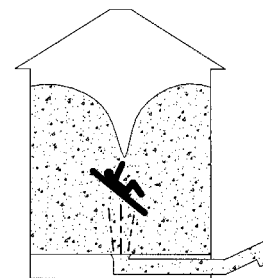

8 seconds

After 8 seconds, you are completely covered.

Grain across bottom and around sides of bin does not move. The speed at which grain is removed makes the funnel flow very dangerous. A person in a bin would be carried to center, quickly drawn under, and suffocated. An 8" auger can transfer 3,000 cubic feet of grain per hour (52 cubic feet per minute). A person about 6' tall displaces about 7-1/2 cubic feet, assuming an average body diameter of 15 inches. This means the entire body could be submerged in a funnel in about 8 seconds. Even more importantly, you could be up to your knees and totally helpless to free yourself in less than 4 seconds.

Grain surface may appear solid but not be. A small opening in unload gate gives entire surface the quality of quicksand. When a single kernel is removed from bottom of bin, kernels directly above it rush to fill the void. Flowing grain is fluid. Objects on surface sink and heavy objects sink faster than small ones.

Flowing grain is like water in that it will exert pressure over entire area of any object that is submerged in it. However, the amount of force required to pull someone up through grain is much greater than in water because grain exerts no buoyant force and has much greater internal friction.

Even if grain has stopped flowing, submerged objects or people are difficult to extract. Even victims with tremendous upper-body strength cannot pull themselves out if they are buried to the chest. The force required to remove someone buried below the surface of grain can easily exceed 2,000 pounds, which is about the same as needed to lift a small car.

If you become trapped in a bin of flowing grain with nothing to hold onto but you are still able to walk, stay near outside wall. Keep walking until bin is empty or grain flow stops. If you become covered in flowing grain, cup your hands over your mouth and take short breaths. This may keep you alive until help arrives. Additional personnel should call for an emergency rescue team or fire department immediately. Ventilate bin with an aeration system but **DO NOT** activate heat source. Wait for emergency crews to arrive before attempting rescue. Offer assistance to rescuers and follow directions given by incident commander.

Bridged & Caked Grain

Spoiled grain tends to clump together and grain that is stored in cold temperatures can appear to have a solid surface while, in reality, it may collapse if walked upon. Be aware of a potential engulfment hazard when walking on surface crust. Never enter a bin unless you know the nature of previous grain removal, especially if any crusting is evident. Proper safety precautions must be taken. **After grain has been removed, look for a funnel shape at surface of grain mass. If grain appears to be undisturbed, then it has bridged and created a cavity.**

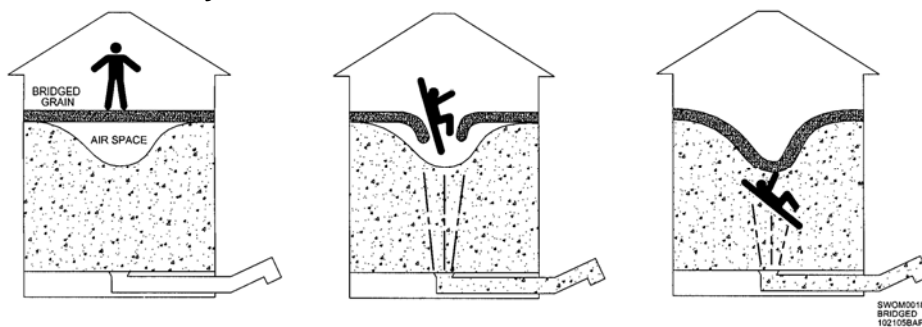

Bridged grain may create air spaces in a partially unloaded bin (see above). As grain is removed from bin, a cavity develops under crusted surface. This situation presents several dangers. First, the person may break through the surface and be trapped instantly in flowing grain. Another danger is that a large void may be created under the bridge by previous unloading so that a person who breaks through crust may be buried under grain and suffocate, even without auger running. The third hazard is that if grain is wet enough to mold and bridge across bin, there may be little oxygen present in cavity due to microbial gases. A person falling into a cavity will be forced to breathe toxic gases, even though his head is above surrounding grain. From outside of bin, use a pole or other object to break bridge, causing it to collapse.

Grain can also cake in a large mass against wall when it has been stored improperly or in poor condition. Mass of grain can cause engulfment or crushing hazards to workers who attempt to break grain loose with shovels or other objects.



This risk increases as capacity of bin increases. A person lying prone and covered by 1 foot of grain will be subjected to a force of over 300 lbs. Be alert while working with grain that has gone out of condition. Entering a bin when there may be molds, blocked flow, cavities, crusting, and possible cave-ins can cost you your life. When you are breaking up large masses of vertically crusted grain, do so with a long wooden pole from manhole above grain.

Moving Parts

When bin is nearly empty, sweep (floor) auger travels at a faster speed around bin. If caught in rotating auger, a body part can be pulled along with grain, cutting and tearing flesh. Also, an exposed auger in a sump can cause serious injury if sump is stepped into or fallen into. All shields should be in place to prevent body parts from getting caught.

To help prevent tragedy, **SAFETY SHOULD BE THE TOP PRIORITY**. Preparation is the first and most important step. Failure to follow precautions listed below may cause death or serious injury.



- Keep hands, feet and clothing away from moving parts. Loose clothing can become entangled in rotating parts and cause serious injury or death.
- Guards and shields are provided for your protection. Make sure all are secure and in place while machine is in operation.
- Replace safety shields that have been damaged or were removed for servicing equipment. Fasten shields securely.
- Be sure to wear tight-fitting clothing when working near a grain auger. Loose, floppy clothing, long shoestrings and drawstrings on hooded jackets can easily become entangled in rotating parts. Entangled clothing will pull the body into moving machinery and severe injury will result.
- Limit number of people around augers when in use. Only those who are essential to job should be there.
- Watch children closely. Never leave them unattended. Keep them away from vehicles, flowing grain and moving parts. Small hands and feet can penetrate even properly shielded augers, belts and PTOs. Teach children which areas are safe and which are not.
- Be certain all machinery is in good working condition.

Lockout/Tagout

Lockout/Tagout refers to specific practices and procedures to safeguard against unexpected energization or startup of machinery and equipment or release of hazardous energy during service or maintenance activities. This requires, in part, that an authorized individual isolate machinery or equipment from its energy source(s) before performing service or maintenance. It also requires authorized individual(s) to either lock or tag energy-isolating device(s) to prevent release of hazardous energy, and take steps to verify energy has been isolated effectively.

Grain storage structures and handling equipment may create hazardous work areas. Individuals should make sure they take proper steps to prevent injuries, illness or death. Be certain proper lockout/tagout procedures are followed before performing any service on equipment or entering bin.

Lockout refers to a device that uses a lock -- either key or combination type -- to hold an energy-isolating device in a safe position and prevent energizing of a machine or equipment. This device ensures that equipment being controlled cannot be operated until lockout device is removed. Tags must be used with all locking devices. Tags should be affixed in a manner that clearly identifies the individual servicing the equipment

Tagout refers to placement of a tag on a device that is not capable of being locked out, to indicate equipment may not be operated until tag device is removed. These tags are singularly identified with the individual applying the device and servicing the equipment. These tags **do not** provide physical restraint on those devices that require a restraint.

Owners/Operators are responsible for developing site-specific Lockout/Tagout procedures based on equipment, conditions and situations at their individual locations. OSHA's Lockout/Tagout procedures (29CFR 1910.147) can be obtained at www.osha.gov.

Ventilation

When entering an inadequately ventilated area, individuals may be at risk of being overcome by respiratory hazards (gases, fumes and dust) that can cause permanent lung damage or even death. Working in grain bins without proper respiratory protection increases a person's chance of developing a respiratory disease.



Owners/Operators are responsible for developing site-specific personal protective equipment standards. OSHA's personal protective equipment standards (29CFR 1910.134) can be obtained at www.osha.gov.

Sharp Edges & Obstacles



When working in, on or near a bin, remember that metal edges are sharp. To avoid injuries, wear protective clothing and handle equipment and parts with care. An excellent safety practice is to keep bin site clear of scrap iron and other foreign materials that may get covered up by snow or tall grass. Items or debris left near bin site may interfere with safe, unobstructed movement around bin.

Be aware of trucks, tractors, wagons, augers, hoppers and pits, etc. Never allow anyone to ride on trucks equipped with grain beds or gravity dump wagons. Keep children off grain vehicles and out of bins while loading and unloading. Always know where all family members are (especially children) at all times when grain is being loaded, unloaded, moved or otherwise handled.

Falls & Obstructions

Falls from grain bins at any height can cause injury. Ladders on bins can become very slippery or icy in inclement weather. Maintain a secure handhold and foothold when climbing on bin. Metal is slippery when wet. Never carry items while climbing on bins. Also, be certain no obstacles are in front of ladder.

Slippery metal, broken or loose ladder rungs and loose handholds can be very dangerous. Repair loose ladder rungs and handholds as soon as they are discovered. Follow maintenance guidelines listed at back of operation manual to prevent serious injury.

Make sure there are no obstructions near ladder rungs. Be certain wind rings (usually on taller commercial bins) are installed according to illustration at right so adequate clearances for hands and feet are provided. Wind rings must be a minimum of 1-1/2" below and 4-1/2" above any ladder rung. A wind ring assembled within 4-1/2" above a ladder rung can interfere with foothold and cause you to fall.

American Society of Agricultural and Biological Engineers (ASABE) standards state that landing platforms shall be provided at each 30' of ladder height. Center of outside ladder must be at least 7" from sidewall.

NOTE: Failure to install ladder and safety cages correctly and to use fall restraint or arrest systems correctly may cause death or serious injury. Contact your dealer if proper ladder and accessories are not installed.

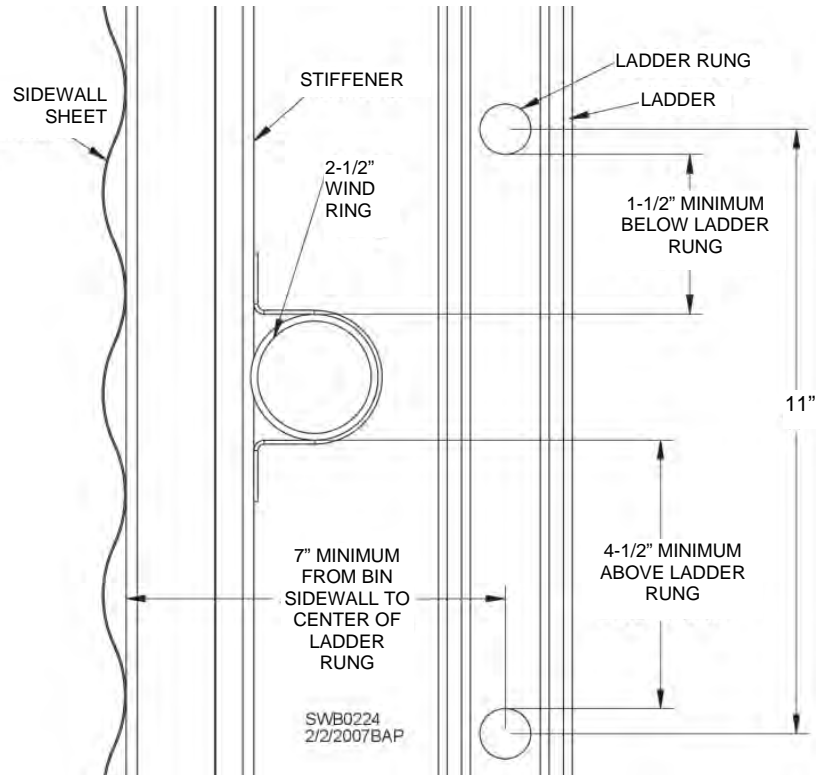

Ladder Safety

- Working load of ladder is 300 pounds. Do not overload.
- Inspect ladder carefully before use. Never climb deteriorated, damaged or improperly assembled ladder components.
- Never use ladder if you are physically impaired.
- Never carry items while climbing.
- Always have another person present while climbing.
- Use safety harness and safety line as required.
- Metal is slippery when wet. Always maintain a firm grip and wear slip-resistant shoes when climbing.
- Always face ladder when using it.
- Never apply external load. Never push or pull anything while on ladder.



WARNING: Failure to follow precautions above may result in death or serious injury.

Fall Restraints & Arrest Systems

When working at a height where fall hazards exist, always use a fall restraint or fall arrest system. Inspect components before each use for wear, damage and other deterioration. Remove defective components from service according to manufacturer's instructions. Failure to heed this warning may cause death or serious injury.

A **fall restraint system** consists of a body belt or harness, lanyard and anchor. The system is arranged so the individual is prevented from falling. Fall restraint systems should be used in accordance with manufacturer's recommendations and instructions.

A **fall arrest system** consists of a harness, lanyard and anchor. The system stops a fall within specified parameters. Fall arrest systems should be used in accordance with manufacturer's recommendations and instructions.

Lifelines and safety harnesses are used with both systems. A **lifeline** is a component consisting of a flexible line (rope or cable) for connection to an anchorage at one end to hang vertically (vertical lifeline), or for connection to anchorages at both ends to stretch horizontally (horizontal lifeline). Lifelines also serve as a means for connecting other components of a fall protection system. A **safety harness** has straps that wrap around an individual in a manner that will distribute the fall arrest forces over thighs, pelvis, waist, chest, and shoulders with a means of attaching it to other components of a fall protection system. Follow manufacturer's instructions when using a lifeline and safety harness.



Individuals who enter a grain storage structure from a level at or above stored grain should be equipped with a lifeline and harness. When entering any bin or storage unit, have multiple people outside and one inside. A single person cannot go for help and give first aid simultaneously.

Connections outside bin on roof should be made to peak ring. Lifelines should not let individual extend past eave of roof. If work needs to be done on portions of sidewall, proper equipment such as lifts or cranes should be used. When working inside bin, appropriate connections should be made to rafters, peak ring or sidewall.

Knot-Passing Pulley & Restraint Anchor

Restraint anchor capable of supporting 1,800 lbs. is provided for use inside of all Sukup bins. **Knot-passing pulley with restraint anchor** is provided for use in commercial bins with roofs rated for 15,000 lbs. or more. See installation instructions in Bin Construction Manual.

A knot-passing pulley is intended to be used with a lifeline and safety harness (neither supplied by Sukup Manufacturing Co.). A feeder line should pass through knot-passing pulley at peak and through restraint anchor at eave of bin near manhole. Feeder line is used to pull lifeline through knot-passing pulley for safety harness attachment. Do not attach safety harness to feeder line. Use safety equipment according to manufacturers' instructions. Refer to Fall Restraints & Arrest Systems section and to www.osha.gov for additional safety information.

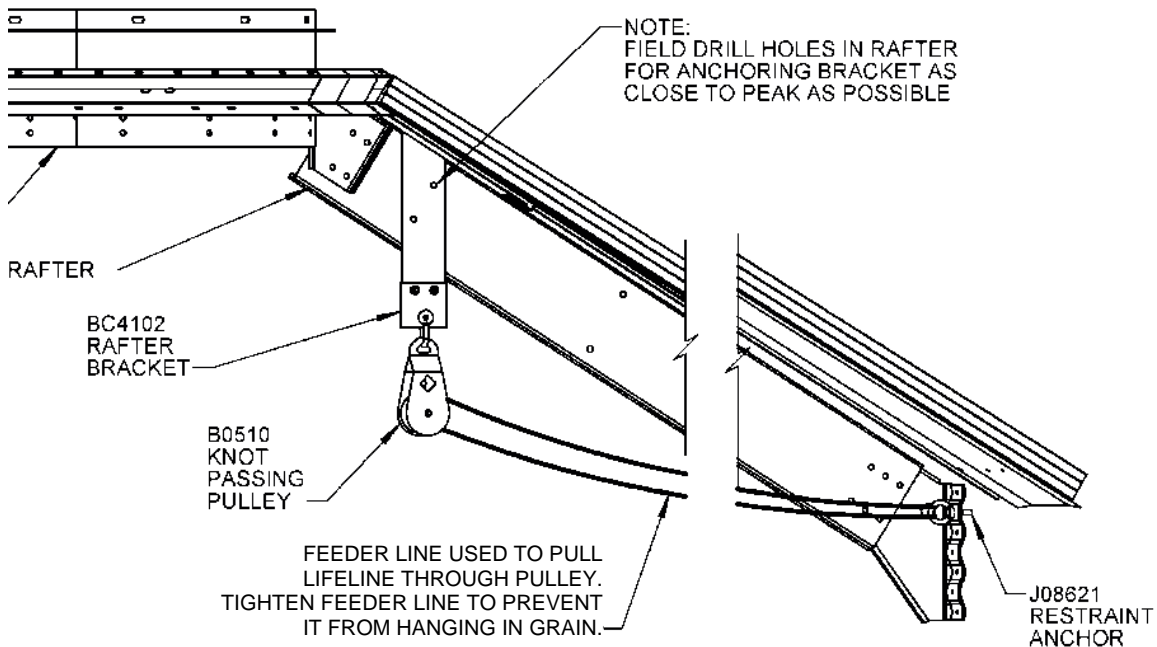
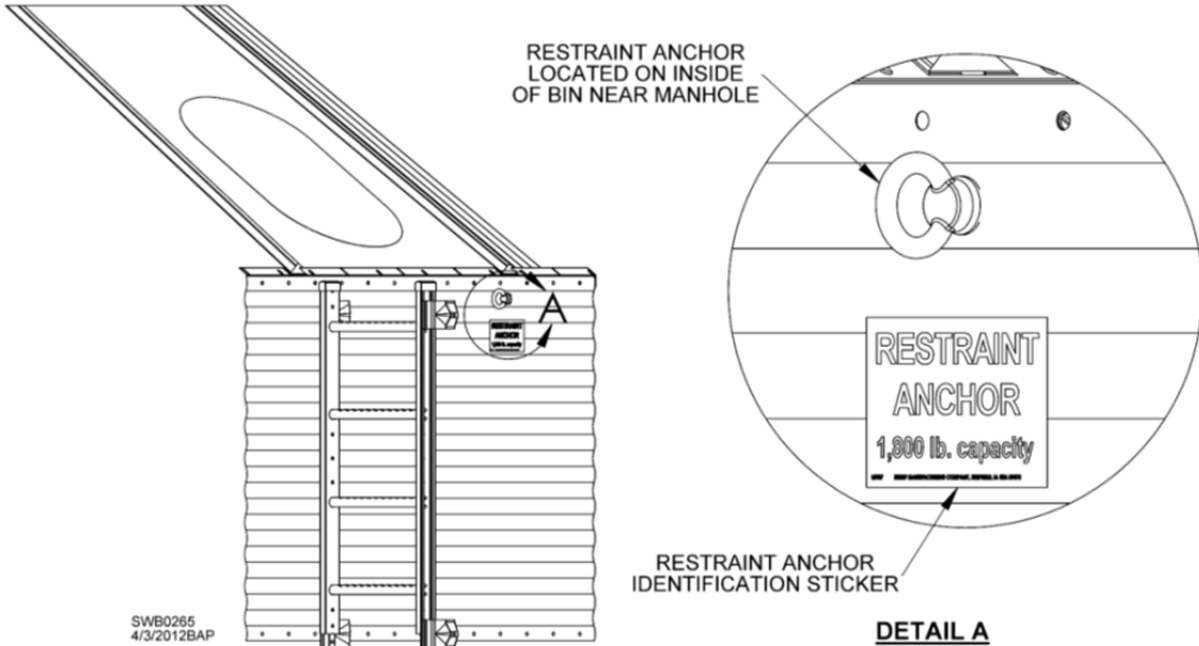

Top Causes of Bin Failure

- **OFF-CENTER (ECCENTRIC) UNLOADING AND/OR LOADING**
- Non-free flowing grain (spoiled, frozen, crusted etc.)
- Door panels not tightly secured against inner door frame
- Augers, spouts, or conveyors improperly attached to roof
- Sidedraw improperly installed or operated
- Rusted wall sheets
- Simultaneous loading and unloading
- Settling of foundation (uneven pad)
- Improper usage (storage and aeration)
- Storing wet and dry grain in the same bin without stirring
- Neglect of bin maintenance
- Modifications made during installation or assembly
- Incorrectly installed sidewall sheets and/or stiffeners
- Blocked roof vents causing excessive pressures on roof (overfilling, frosted vents, etc.)
- Improper temperature cable support and/or placement

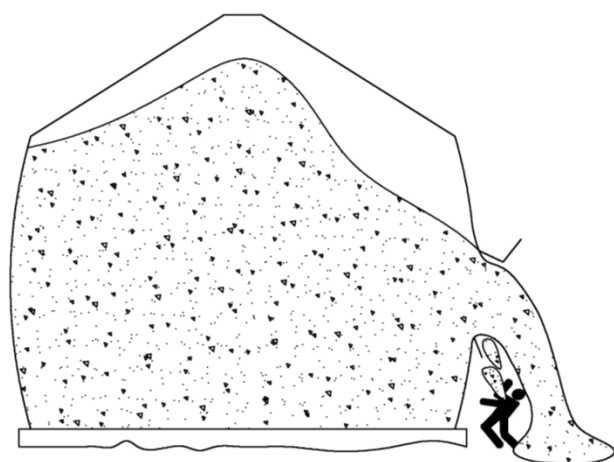

SWOM0030
9/3/2011BAP



WARNING: Damage from issues listed above may cause sudden structural failure and collapse, which may result in death or serious injury. Frequently monitor and inspect bin and foundation for any deflections, cracks or deviations that may occur. Follow operation and maintenance instructions described in this manual.

Determining an Existing Bin's Fitness for Duty

Farm and commercial bins are built to last for many years. However, factors such as weather, usage, accidents and seismic activity can put stresses on a bin that compromise its structural fitness. Following are issues to consider in determining whether a bin should be taken out of service and/or replaced.

- Extensive rust on inside or outside of roof and/or sidewall sheets, or on stiffeners
- Rust holes or significant wearing and/or tearing of roof and/or sidewall sheets
- Damaged stiffeners or sidewall sheets (kinked or bent from off-center loading or unloading, etc.)
- Leaking roof or sidewalls
- Missing connections between wall and roof structure
- Missing or sheared bolts
- Loose, broken or shifted anchors
- Damaged foundation or bin floor (cracks in concrete foundation, uneven settlement)

Minor levels of any of these issues should be repaired promptly. If levels are moderate to high, bin should be taken out of service or replaced. If unsure, take pictures of the issues and contact an independent consulting engineer.

Besides condition of bin, other factors to consider in determining whether to decommission it include age of bin, insurability, capacity, compatibility with modern grain handling and moving equipment, and future plans for bin site.

Construction Safety

On grain bin construction sites, carelessness and/or operator error may result in serious injury or death. Hazard control and accident prevention depend on awareness, cautiousness, and proper training of personnel involved in construction of bin. Be certain all crew members are properly trained and thoroughly familiar with all aspects of grain bin construction.

Listed below are items construction crew members should be knowledgeable of to minimize risk of injury to personnel and damage to equipment. **NOTE:** Following items are examples taken from a broad list of OSHA's Safety and Health Regulations for Construction. Generally, these are common requirements/items necessary on grain bin construction sites.

- **Personal Protective**
 - Head Protection
 - Hearing Protection
 - Eye and Face Protection
 - Steel Toed Boots/Shoes
 - Gloves
- **Concrete Construction**
- **Material Handling & Storage**
- **Tools – Hand and Power**
- **Welding and Cutting**
- **Electrical**
- **Ladders**
- **Scaffolds and Working Platforms**
- **Fall Protection**
- **Steel Erection**
 - Center Pole (Roof) Jack*
 - Sidewall Jacks*
- **Motorized Equipment**
 - Trenchers
 - Forklifts
 - Skidsteers
 - Telehandlers
 - Boom Lifts
- **Cranes and Hoists**
- **Signs and Signals for Use of Motorized Equipment**

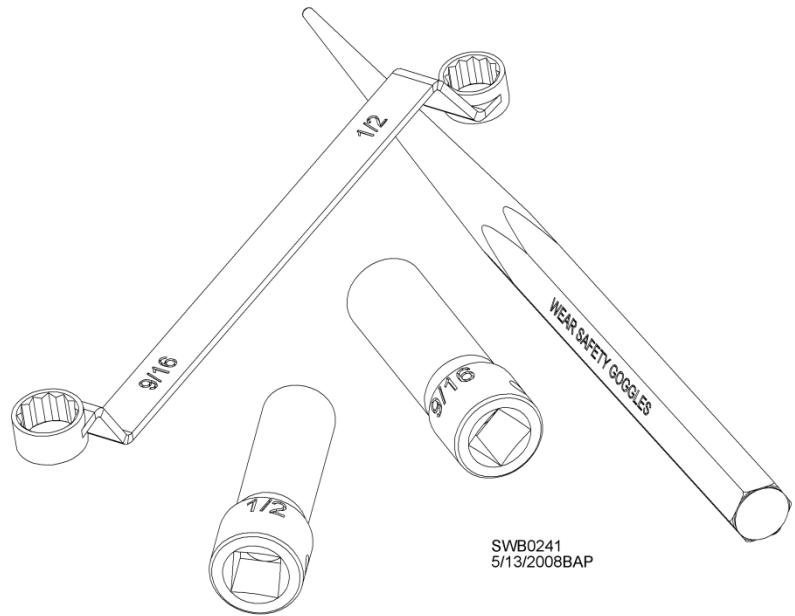

***NOTE:** Be certain to read and fully understand correct operating procedures for bin jacking equipment. This equipment is provided with understanding that purchaser/operator are thoroughly familiar with correct applications and proper usage techniques. Jack manufacturers will assume no responsibility for damage to equipment or any injury resulting from operation of their equipment.

Erectors/contractors are responsible for developing site-specific construction guidelines and procedures based on equipment, conditions and situations at their individual location. OSHA's Safety and Health Regulations for Construction (29CFR1926) can be obtained at www.osha.gov.

Bin Operation & Management

Bin Description

Sukup Manufacturing Co. grain bins are designed to meet a wide variety of needs, but all bins cannot be used for all purposes. Listed below are different types of grain bins made by Sukup. See following page for application definitions. **Check to be certain which type of bin you ordered and received. Bin number is listed on quote from dealer or on color chart that comes with bin.** Example below illustrates how bin numbers are read. Circle the bin you ordered.

| <u>Prefix</u> | <u>Description</u> |
|---------------|----------------------------------------|
| B..... | Farm Bins |
| BD..... | Farm Heavy Gauge Drying Bins |
| BS..... | Farm Stiffened Bins |
| BSD..... | Farm Stiffened Heavy Gauge Drying Bins |
| BHM..... | Medium Duty Hopper Bins |
| BH..... | Heavy Duty Hopper Bins |
| BC..... | Commercial Bins |

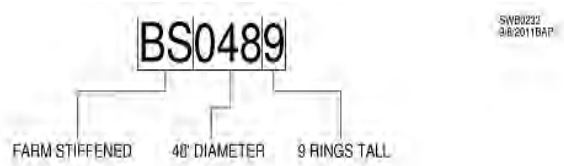

NOTE: Bin numbers ending with an “X” indicate bin with a special design. Look for label on inside of door for specific design/usage information.

(B) Farm Bins: 15’ to 48’ in diameter, maximum 10 rings tall.

- Bins are designed for storage, aeration and short-term wet holding.
- Limitation - Bins up to six rings are designed for stirring machine and general drying. May use stirring device with up to three down augers. Bins seven or more rings tall are not designed for a stirring machine.

(BD) Farm Heavy Gauge Drying Bins: 18’ to 48’ in diameter, five or six rings tall.

- Designed for general drying, general wet holding, working and storage. May use stirring device with up to five down augers, center unload continuous flow system or recirculating devices.

(BS) Farm Stiffened Bins: 15’ to 48’ in diameter, maximum 12 rings tall.

Bins are designed for storage, aeration and short-term wet holding.

- Limitation - Bins up to six rings are designed for stirring machine and general drying. May use stirring device with up to three down augers. Bins seven or more rings tall are not designed for a stirring machine.

(BSD) Farm Stiffened Heavy Gauge Drying Bins: 18’ to 48’ in diameter, five or six rings tall.

- Designed for general drying, general wet holding, working and storage. May use stirring device with up to five down augers, center unload continuous flow system or recirculating devices.

(BHM) Medium Duty Hopper Bins: 15’ to 21’ in diameter, three to six rings tall.

- Designed for corn and sorghum (48lbs./ft.³) storage, aeration and short-term wet holding; NOT DRYING.
- Limitation - 45° Medium Duty Hopper bins can be utilized as working bins if total grain depth (outlet cone to peak) is less than twice the bin diameter. **IMPORTANT:** Monitor cone panel wear with heavy use.

(BH) Heavy Duty Hopper Bins: 15’ to 36’ in diameter, three to 12 rings tall.

- Designed for storage, aeration and short-term wet holding; NOT DRYING.
- Limitation - 45° Heavy Duty Hopper bins can be utilized as working bins if total grain depth (outlet cone to peak) is less than twice the bin diameter **IMPORTANT:** Monitor cone panel wear with heavy use.

(BC) Commercial Bins: 18’ to 156’ in diameter, 13 rings and taller.

- Designed for storage only; NOT DRYING. Store only dry, cool, free-flowing grain.
- Limitation - May be used for short-term wet holding on 60’ diameter and smaller bins, max 12 rings tall.

Bin Usage

Table below shows uses for which each bin is designed.

| | | | | | | | | |
|-------------|---|-------------------------------|---|-----------------------------------|----------|------------------------|----|-----------------------------|
| Key: | ✓ | Designed for this application | ∅ | NOT designed for this application | Limited* | Limited by size of bin | SQ | Special Quote Contact Sukup |
|-------------|---|-------------------------------|---|-----------------------------------|----------|------------------------|----|-----------------------------|

| Type | Bin | Application | | | | | | | |
|--------|-----|------------------|----------|------------------|---------|------------------------|---------------------|----------|----------|
| | | Storage/Aeration | Drying | Stirring Machine | Cooling | Short-term Wet Holding | General Wet Holding | Working | Sidedraw |
| FARM | B | ✓ | Limited* | Limited* | ✓ | ✓ | ∅ | ∅ | ∅ |
| | BD | ✓ | ✓ | ✓ | ✓ | ✓ | ✓ | ✓ | ∅ |
| | BS | ✓ | Limited* | Limited* | ✓ | ✓ | ∅ | ∅ | ∅ |
| | BSD | ✓ | ✓ | ✓ | ✓ | ✓ | ✓ | ✓ | ∅ |
| HOPPER | BHM | ✓ | ∅ | ∅ | ∅ | ✓ | ∅ | Limited* | ∅ |
| | BH | ✓ | ∅ | ∅ | ∅ | ✓ | SQ | Limited* | SQ |
| COMM. | BC | ✓ | ∅ | ∅ | ∅ | Limited* | SQ | SQ | ✓** |

* See previous page to determine available sizes

** Available on bins up to 105' diameter

Application Definitions

Storage – Storing dry, cool, free-flowing grain only. Generally should include an aeration method.

Aeration – Using fan(s) with full floor or aeration tunnels to keep dry grain within 10°F (6°C) of ambient air temperature.

Drying – Drying wet grain to proper moisture content for storage. Type of grain and length of storage time will determine proper moisture content.

Stirring Machine – Mixing grain using stirring augers while drying to ensure uniform condition.

Cooling – Requires full floor and properly sized fan(s) to achieve adequate cooling.

Short-term Wet Holding – Storing wet grain (over 16% moisture) up to 72 hours. Aeration is needed.

General Wet Holding – Storing wet grain (over 16% moisture) more than 72 hours. Aeration is required.
NOTE: Grain will deteriorate faster as temperature and moisture content increase.

Working – Refilling 25% or more of maximum bin capacity more than 12 times a year, where new grain settles for more than 72 hours per occurrence. Working bins require grain to be unloaded by gravity out of center sump only.

Sidedraw – Controlled removal of grain from side of bin. Available only on commercial bins. Sidedraws are not to be used as a primary outlet in a working bin application. If 25% of maximum capacity will be withdrawn more than 12 times a year through sidedraw, a special sidedraw working bin needs to be designed. Contact Sukup Manufacturing Co. customer service.

Be sure to review bin descriptions on previous page for proper usage.

The following pages contain more information on operation and management of grain bins. Each section will include one of the tags below (FARM, HOPPER, COMM., ALL) that identifies which type of bin applies to that section. The ALL tag means the section refers to farm, hopper and commercial bins.

FARM

HOPPER

COMM.

ALL

ALL

Initial Fill

INSPECTION CHECKLIST BEFORE FIRST OPERATIONAL USE

- Bin has been properly anchored to foundation. Anchor nuts should be finger-tight against shims.
- Ladders, handrails, platforms, stairways and steps are securely in place.
- All bolts are in place and securely tightened.
- Unloading equipment and unload gates function correctly and are closed.
- All guards and shields are in place. Safety decals are legible and in correct locations.
- Working areas surrounding bin are clean and clear of clutter.
- Check electrical performance and install lockouts (if needed) on equipment.
- Any temperature cables must be fastened to floor using breakable string (fishing line). Absolutely no weights or plates should be attached to bottoms of temperature cables that could overload roof.

On larger bins, filling in several stages as described below is required to prevent uneven settlement. **These instructions are general guidelines. Follow soil engineer's instructions on initial filling.**

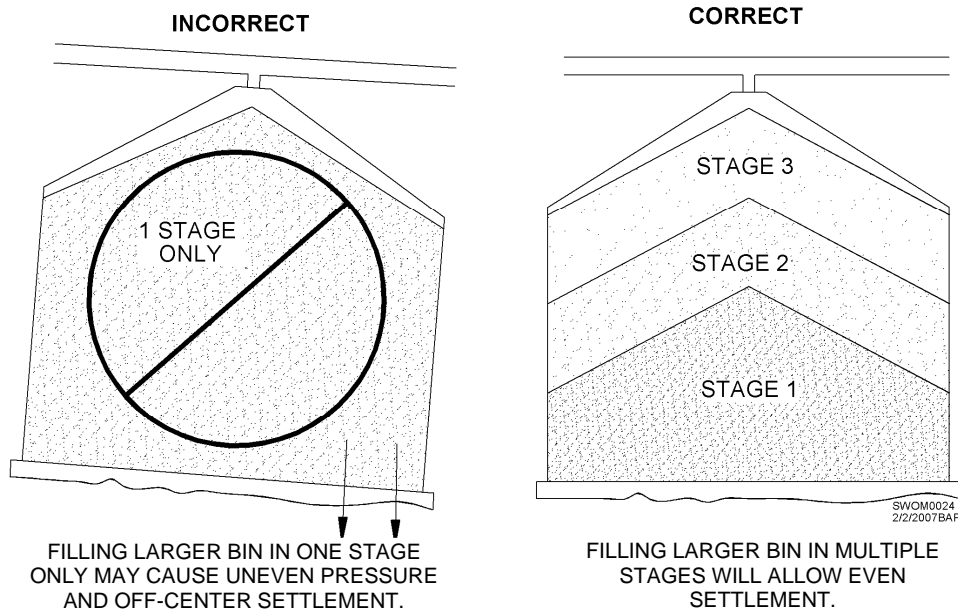

Maximum uneven settlement (deviation) after filling bin (includes overall concrete deviation before bin erection):

For 60' diameter and smaller: 1-½" MAX

For larger than 60' diameter: 2" MAX

COMM.

IMPORTANT COMMERCIAL BIN INFORMATION: Sukup Manufacturing Co. requires stage loading to prevent excessive uneven differential settlement after first initial fill. In first stage, bin should be filled to no more than 1/3 of eave height. It would then take 10 days for desired consolidation to occur. For second stage, bin should be filled to 2/3 of eave height. It would then take another 10 days for desired consolidation to occur. Then the final 1/3 may be filled. See illustration above.

FARM

IMPORTANT FARM BIN INFORMATION: If eave height is greater than bin diameter, bin should be filled in two stages. First stage should be to height of bin's diameter. Allow 10 days for consolidation to occur, and then continue to fill rest of bin. If height is not greater than bin diameter, initial fill can be completed in a 24-hour period.

ALL

Loading

Below are maximum fill rates depending on type of bin.

Farm Duty – 2-1/2 feet per hour (2/3 sidewall ring per hour).

Commercial – 5 feet per hour (1-1/3 sidewall rings per hour).

Do not exceed 50,000 bushels per hour fill rate.

NOTICE: Replacing loading equipment with higher capacity equipment may increase dynamic loads on a bin. Increased dynamic loads on bin sidewalls can cause distress, distortion and structural failure.

If faster fill rates are desired, contact Sukup Manufacturing Co.

INCORRECT OFF CENTER (ECCENTRIC) LOADING

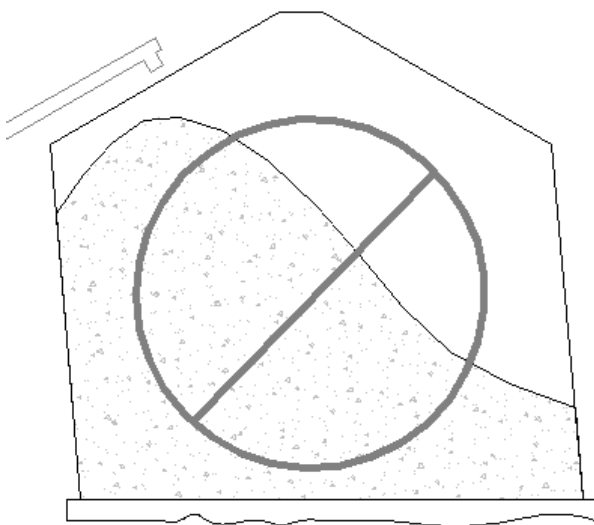

OFF-CENTER LOADING CAN CAUSE
EXCESSIVE PRESSURE ON SIDEWALL
RESULTING IN LEANING OF BIN OR
STIFFENER BUCKLING.

CORRECT CENTER LOADING

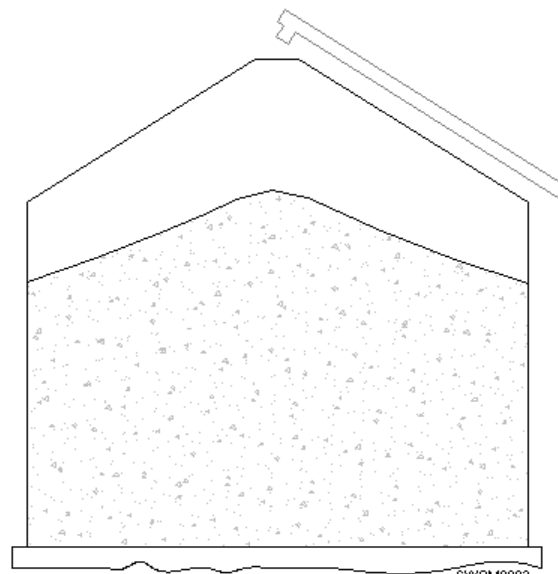

BIN MUST BE LOADED THROUGH CENTER
OF ROOF SO GRAIN IS UNIFORMLY
DISTRIBUTED.

SWOM0002
LOADING
7/8/2008BAP

CHECKLIST FOR FILLING BIN

1. Check that unloading equipment is functioning correctly.
2. Close all intermediate sump gates.
3. Place power sweep auger, if so equipped, over intermediate sumps.
4. Shut sidewall door(s) properly. Inner door panels must be fully seated against frame over all 1" pegs when closed and latched.
5. Fill only through center peak ring.
6. Know the maximum capacity of bin. Overfilling may cause bin failure. Maximum capacity is when grain is 1" below eave. Use spout/chute to prevent overfilling. See Spout/Chute Lengths page.

ALL

Unloading

Standard bins are NOT designed as working bins. A bin is considered a working bin when 25% or more of maximum capacity is withdrawn more than 12 times a year. If bin is to be a working bin, a special heavier design must be used.

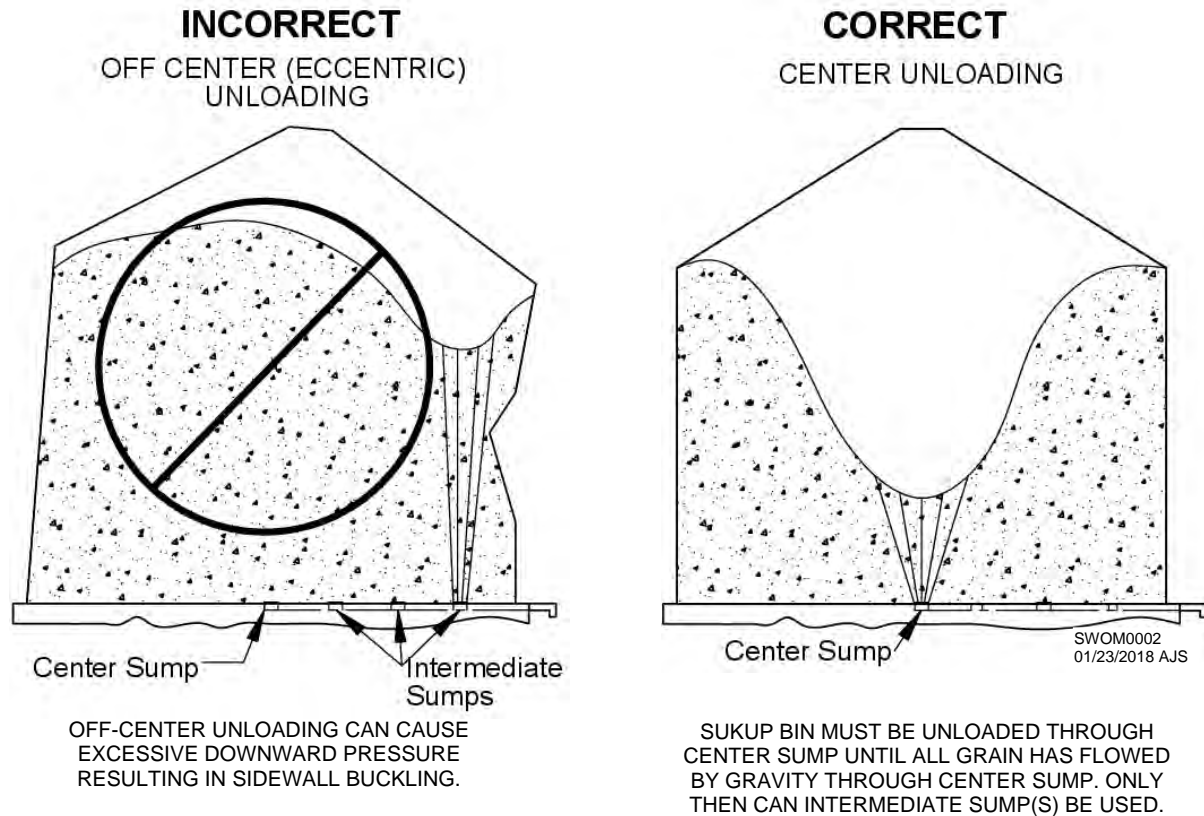

To maintain uniform loads on sidewalls, grain must be unloaded from center of bin. **Center sump must be opened first.** Intermediate sump(s) must not be used until all grain has flowed by gravity through center sump.

NOTICE: DO NOT simultaneously fill and unload bin. Simultaneous filling and unloading results in grain behaving more like a fluid than granular material. Increased fluidic behavior of grain can cause increased sidewall loads. Service life of bin can be drastically reduced and risk of structural failure, personal injury and economic loss will increase by simultaneous loading and unloading.



WARNING: Off-center unloading could result in structural failure causing death or serious injury. Never vacuum out of sidewall door unless all grain has been emptied by gravity through center sump and then intermediate sump(s). Do not empty bin through sidewall door or cut a hole in bin sidewall. This will cause uneven load distribution and excessive downward pressure that may result in bin failure.

NOTICE: Replacing unloading equipment with higher capacity equipment may reduce structural integrity of bin. Discharging grain at very high capacities alters dynamic loads on bin sidewall, possibly exceeding load capacity and resulting in collapse. Consult an independent engineer before proceeding with modifications.

ALL

Sweeping Bin



DANGER: Never enter bin while equipment is operating. Lock out all equipment and have another person present when entering bin. When bin is nearly empty, sweep auger will travel at an increasingly fast speed. Keep away from auger to avoid entanglement, which will result in death or serious injury.

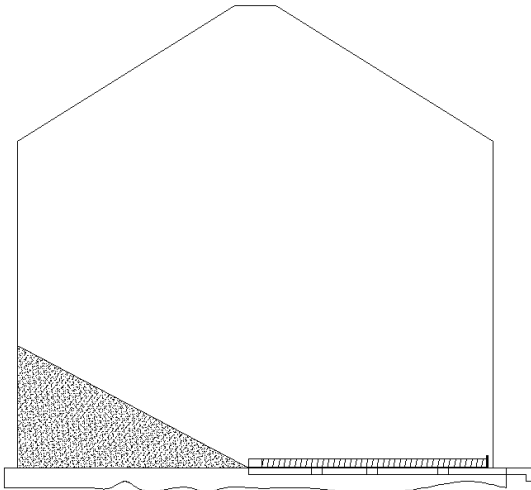

Single-Stage Sweeping

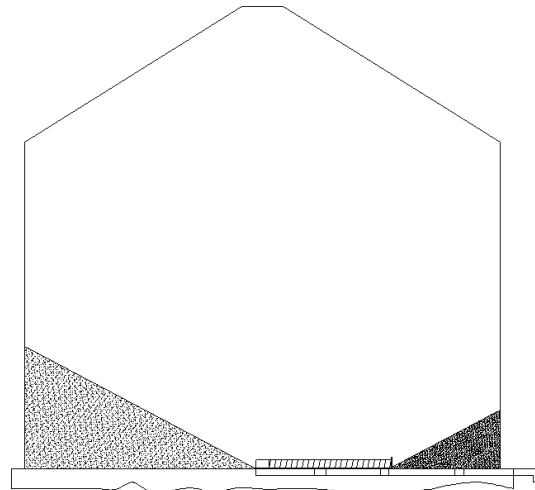

SWOM0025
112106BAP

Multiple-Stage Sweeping

Standard Sukup grain bins are designed with anchors that allow sweeping of entire diameter of bin in one stage. However, older Sukup bins 72' dia. and larger that do not have two anchors per stiffener should be swept in multiple stages beginning with inner section of floor, and then outer section after sweep extension is added. Additional anchor brackets can be purchased from Sukup Manufacturing Co. and retrofitted to enable single-stage sweeping.

For single-stage sweeping of Sukup bins 54' to 105' in diameter, bin must have 1" Grade 5 anchor bolts (17" deep for "Inverted T" foundation, or deep into stemwall ring rebar zone for "T-Cap"), with a minimum of 7-1/2" from anchor to outside edge of stemwall. Check bin anchor specifications prior to using sweep.

STEPS TO SWEEPING BIN

1. Be certain that no bridged grain or vertical crusting is evident.
2. Start to sweep bin after all grain has flowed by gravity through center sump first, then intermediate sumps.
3. For Sukup Sweepway systems, stop equipment and engage clutch to remove grain. Sweepway system is permanently installed so there is no need to enter bin. Turn on power to unload grain.
4. If you have a multiple-stage sweep, lock out inner sweep system before adding outer sweep section. Have another person present.
5. If auger system fails, do not cut holes in bin sidewall to unload. This will cause uneven load distributions that may cause bin failure. Call your nearest Sukup dealer for appropriate procedures. Not following these steps will cause structural damage and loss of bin contents.
6. Return sweep to original position just behind intermediate sump gates.

Material Stored

Storage bins are designed to store only dry, free-flowing grain that has been cooled. **Do not put grain exceeding 16% moisture in a storage bin.** Only drying bins using a stirring machine can hold a mix of wet and dry grain for a limited amount of time. **NOTICE:** Buckling of sidewall sheets can occur due to grain on bottom drying and shrinking. This allows wet grain above to be supported only by bin sidewall. Failure generally develops in area of drying front.

INCORRECT

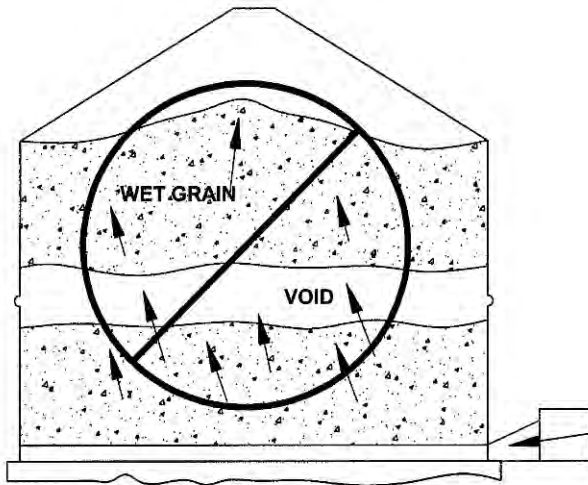

CORRECT

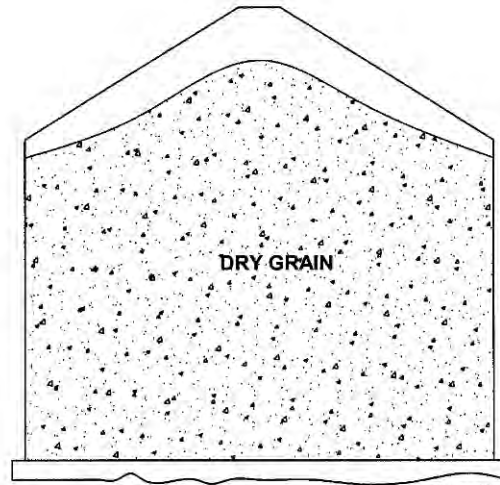

SWOM0006
STORED1
51805BAP

Do not mix quantities of wet grain with dried grain unless it's in a bin with an operating stirring machine. Partially dried grain shrinks and causes voids. Sidewall and stiffeners can buckle under immense pressure. Standard storage bins are not designed for storage of high-moisture grains.

INCORRECT

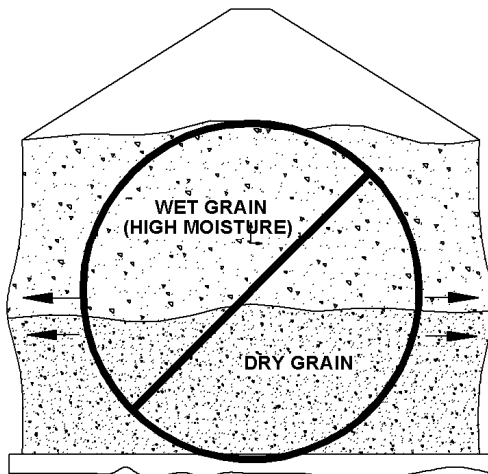

CORRECT

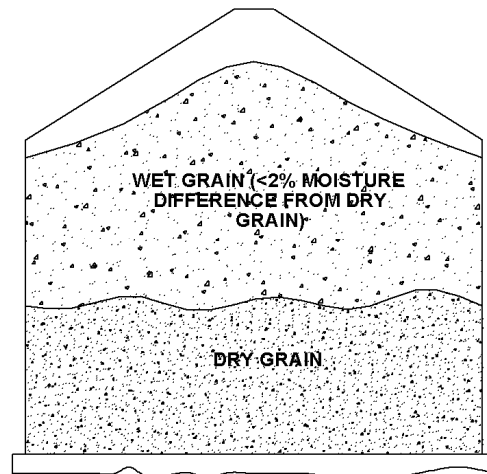

SWOM0006
STORED2
51805BAP

To guard against excessive sidewall loads caused by grain kernel expansion, **grain bins must be managed to prevent grain moisture from increasing above 16% during storage.** In addition, do not have grain moisture content variations of more than 2 moisture points in a storage bin. See warning in Aeration section on avoiding frozen grain in bins.

ALL

Material Stored

DO NOT FREEZE GRAIN due to problems it can create, particularly during warming and in larger bins. Condensation during aeration can be a problem in grain cooled below freezing. It will be difficult to warm grain in spring without condensation immediately freezing into ice. Frozen chunks block aeration warming cycles and grain unloading. **NOTICE: Condensation also re-wets grain and can cause sudden bin failure and collapse due to expansion of kernels.** If grain does freeze, begin thawing it once the average outdoor temperature is 10°F to 15°F (6°C to 8°C) above grain temperature. Follow steps outlined in segment below. **NOTICE: Failure to follow instructions for thawing frozen grain may result in sudden bin collapse and failure.**

INCORRECT

CORRECT

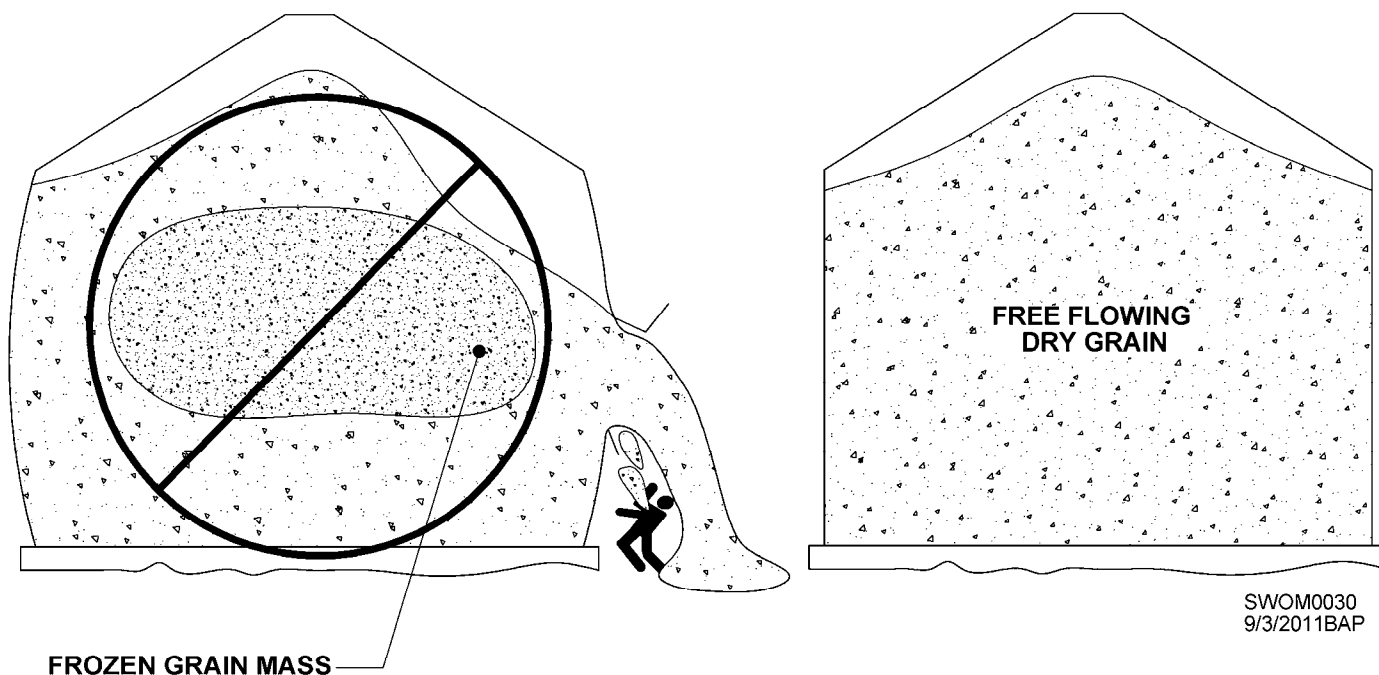

WARNING: Damage from frozen grain may cause sudden structural failure and collapse, which may result in death or serious injury. Frequently monitor and inspect bin. Follow operation and maintenance instructions described in this manual.

Managing Grain in Spring and Summer

Start fan when average outdoor temperature is 10°F to 15°F (6°C to 8°C) above grain temperature. Once warm-up cycle is started, do not turn fan off. Stopping the warming front before a cycle is completed encourages condensation of moisture and spoilage. As outside temperatures continue to warm, repeat this cycle as often as needed until average grain temperature is 50°F to 60°F (10°C to 16°C). **Maintain grain temp. within 10°F to 15°F (5°C to 8°C) of average monthly temp.** Do not warm grain to summer temperatures above 60°F (16°C) in the southern U.S. or 50°F (10°C) in the northern U.S. due to insect infestation and other storage issues.

ALL

Material Stored

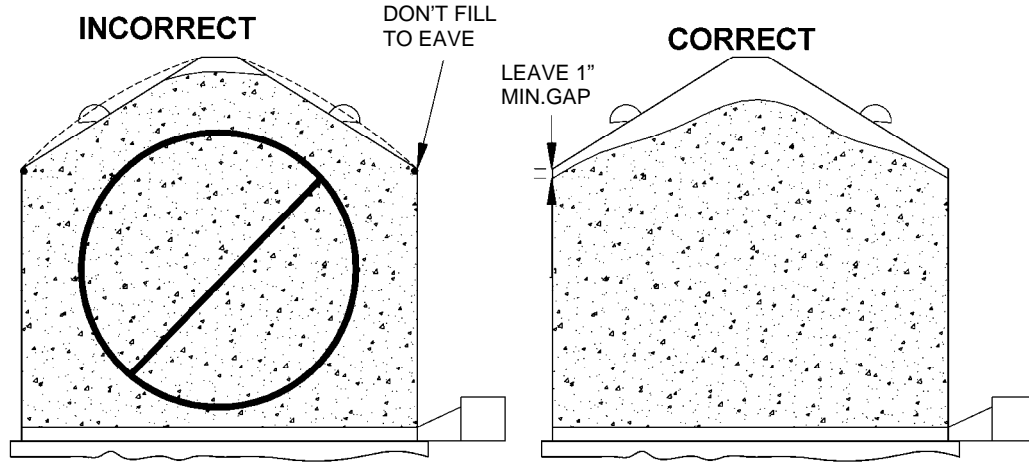

SWOM0019

Do not plug eave and fill grain to top. Filling grain up against roof sheets may cause roof to expand outward and fail, voiding warranty. **Maximum fill height is 1" below eave.** Opening manhole when a bin is overfilled will cause grain to spill out, possibly resulting in someone being caught in grain flow. Check for overfilling by tapping against manhole cover before opening. A hollow sound means it's OK to open cover. A solid sound means grain is against it. **DO NOT OPEN manhole cover when there is grain against it.** Unload bin to get grain away from roof. Be certain ladder cages and platform handrails are in place and correctly installed. See Spout/Chute Lengths page.

FARM

Stirring Machines

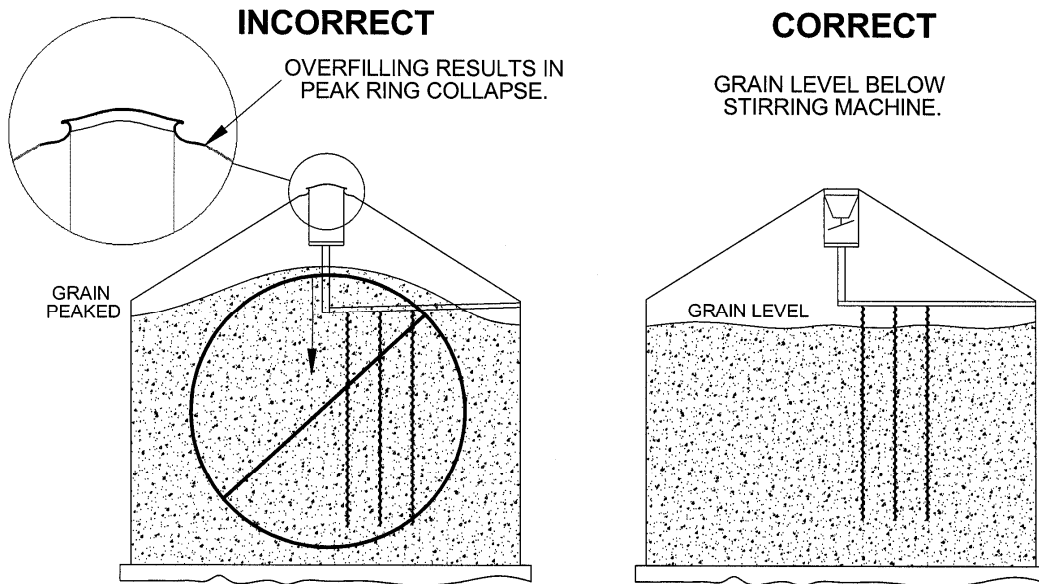

SWOM0015
111005BAP

Stirring machine should be run continuously while filling. **NOTICE: Do not fill bin with grain above stirring machine. Grain should be level 30" below eave. Roof peak ring failure can occur, especially during unloading.** See illustration above. Down augers should be free prior to start-up. Preceding notes are general operating instructions. Be sure to read and understand stirring machine operator's manual before operating.

ALL

Spout/Chute Lengths (To prevent overfilling bin and off-center unloading)

When grain is being peaked, it is recommended that a spout or chute be used to stop grain when it has reached its recommended peak filling height. This keeps grain at least 1" below eave, allowing maximum storage. Listed below are proper lengths for spouts/chutes when filling bins with either dry or wet corn (22° is dry and 28° is wet). Spout lengths are based on spout diameter of 20". Wet corn should not be stored for more than two days. "L" dimensions (see drawings and tables below) are taken from top of peak ring. **IMPORTANT:** Do not use these dimensions on other grains.

22° ANGLE OF REPOSE (DRY CORN)

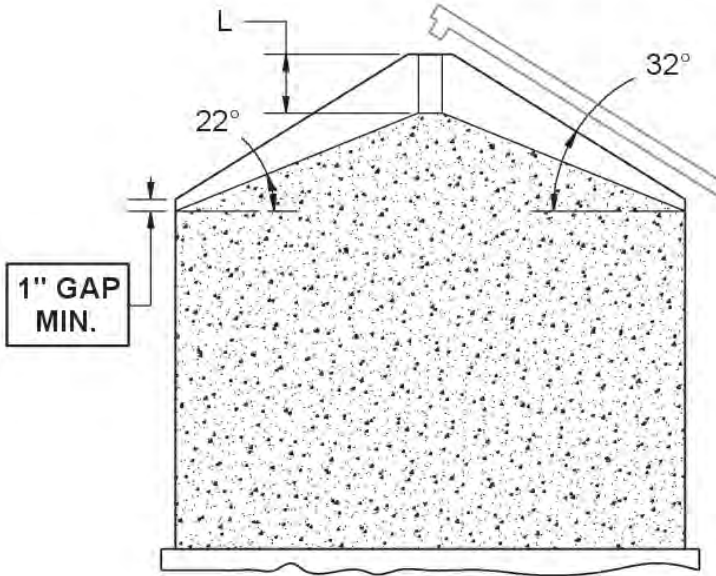

| 5K FARM BINS | | 15K & 30K COMM. BINS | | 50K COMM. BINS | |
|--------------|-------|----------------------|--------|----------------|--------|
| 15' | L=17" | 36' | L=40" | 90' | L=85" |
| 18' | L=21" | 39' | L=44" | 105' | L=106" |
| 21' | L=25" | 42' | L=48" | 135' | L=146" |
| 24' | L=29" | 45' | L=52" | 156' | L=148" |
| 27' | L=33" | 48' | L=56" | | |
| 30' | L=37" | 54' | L=64" | | |
| 33' | L=41" | 60' | L=72" | | |
| 36' | L=45" | 72' | L=92" | | |
| 39' | L=49" | 75' | L=96" | | |
| 42' | L=53" | 78' | L=100" | | |
| 45' | L=57" | 90' | L=115" | | |
| 48' | L=61" | 105' | L=135" | | |

NOTE: LENGTHS ABOVE ARE BASED ON 20" DIAMETER SPOUT.

28° ANGLE OF REPOSE (WET CORN)

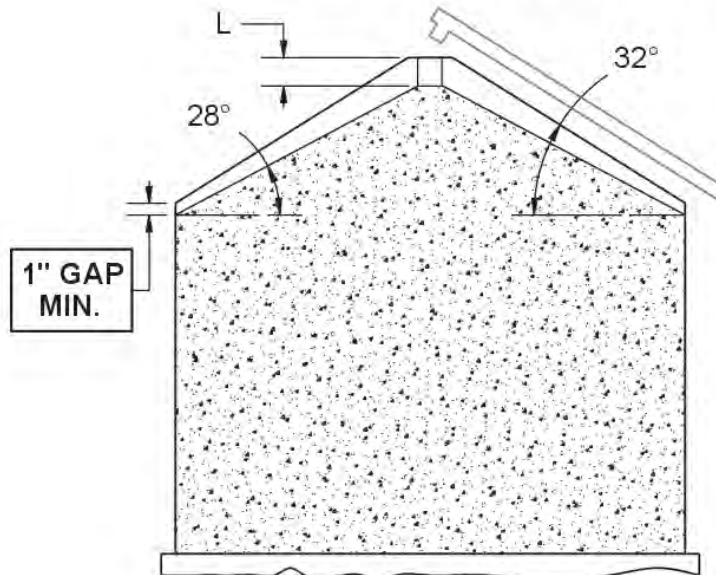

| 5K FARM BINS | | 15K & 30K COMM. BINS | | 50K COMM. BINS | |
|--------------|-------|----------------------|-------|----------------|-------|
| 15' | L=7" | 36' | L=14" | 90' | L=22" |
| 18' | L=9" | 39' | L=16" | 105' | L=31" |
| 21' | L=11" | 42' | L=17" | | |
| 24' | L=12" | 45' | L=19" | | |
| 27' | L=14" | 48' | L=21" | | |
| 30' | L=16" | 54' | L=24" | | |
| 33' | L=17" | 60' | L=27" | | |
| 36' | L=19" | 72' | L=38" | | |
| 39' | L=21" | 75' | L=40" | | |
| 42' | L=22" | 78' | L=42" | | |
| 45' | L=24" | 90' | L=48" | | |
| 48' | L=26" | 105' | L=57" | | |

NOTE: LENGTHS ABOVE ARE BASED ON 20" DIAMETER SPOUT.

SWOM0020
09/30/2015 JLT

ALL

Ventilation

Grain bin roofs are not designed to withstand excessive air pressure differentials. General recommendations are 1 ft² (.093 M²) opening for every 1500 CFM (2550 m³/hr.) that fan will produce. Power roof vents may also be used.

Be alert to the possibility of frost buildup on air passage screens to the point of complete blockage. This may occur when high relative humidity, high grain temperatures or high grain moisture levels are combined with freezing or near freezing temperatures. Running fan(s) during these conditions can create frost buildup and airflow blockage causing roof to dome. Precautionary measures must be taken to prevent this condition. Keep peak and manhole lids closed during storage; open them whenever fans are run.

INCORRECT

FAILURE TO OPEN MANHOLE,
PEAK CAP AND ROOF VENTS
WHEN FAN IS TURNED ON

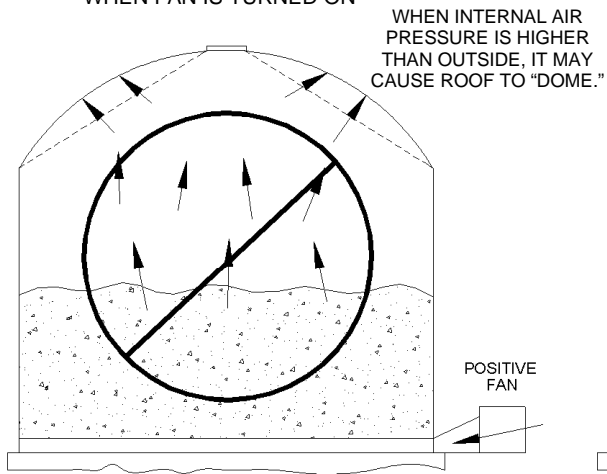

CORRECT

ROOF VENTS, PEAK CAP
AND MANHOLE OPEN

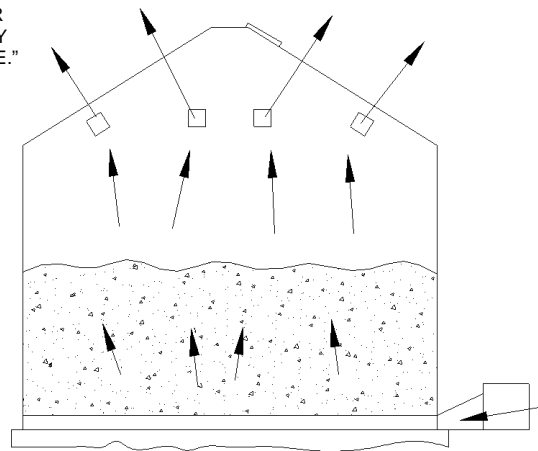

FAILURE TO HAVE
ADEQUATE ROOF VENTS
FOR AIR INLET

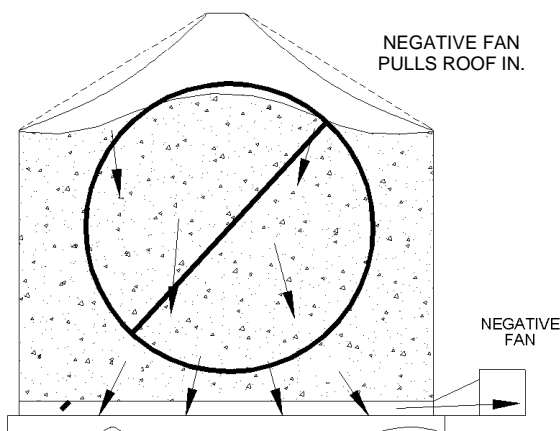

ADEQUATE ROOF
VENTS FOR AIR INLET

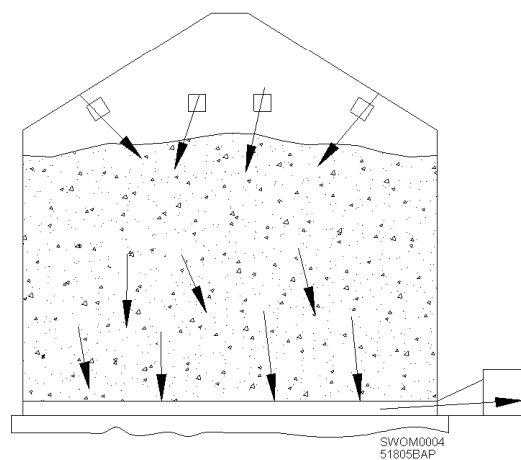

DO NOT USE NEGATIVE (SUCTION) AERATION.

SWGM0004
51605BAP

ALL

Ventilation

BLOCKED ROOF VENTS

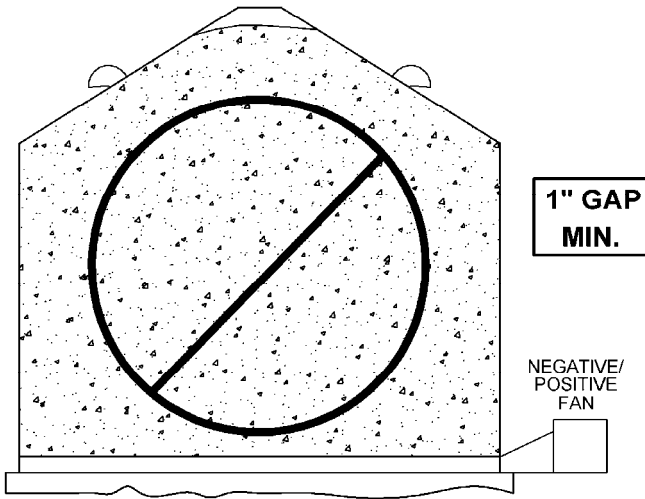

UNBLOCKED ROOF VENTS

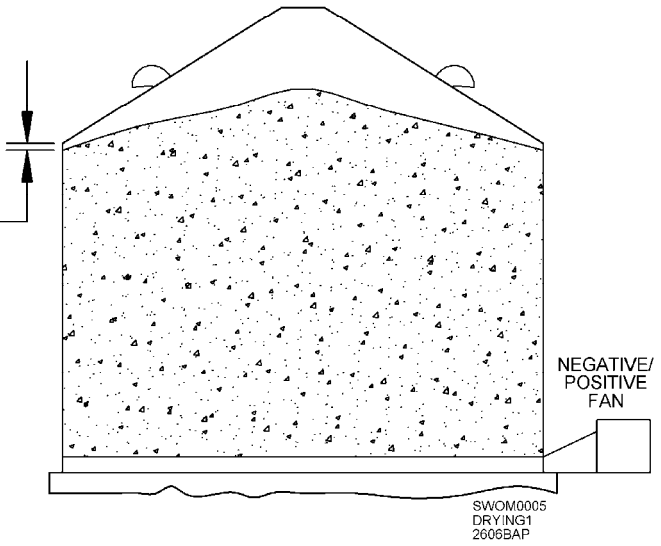

SWOM0005
DRYING1
2606BAP

Do not pile grain against roof. Grain piled too high will block roof vents. Blockage of roof vents will restrict effective vent area by 95-98%, virtually eliminating vent area. Area above surface of grain must allow free movement of air to vents. Be aware of possibility that screens of roof vent may collect moisture and freeze shut. This can happen when high relative humidity, high grain temperatures, or high grain moisture levels are combined with freezing or near freezing temperatures. Do not run fan(s) during these conditions. Running fan(s) during these conditions can create frost buildup and airflow blockage causing roof to dome.

INCORRECT

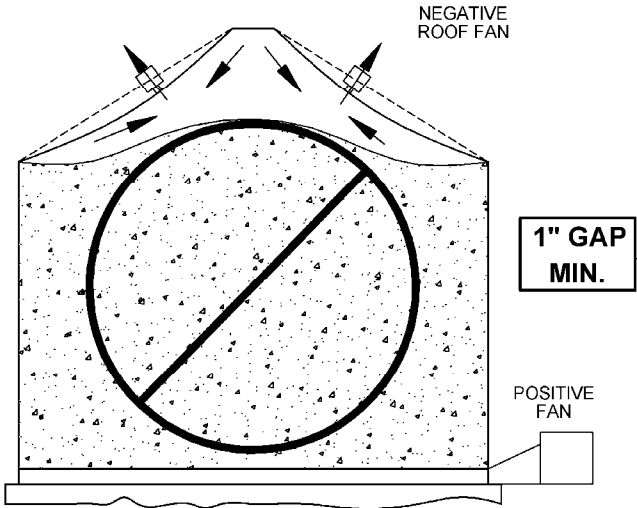

CORRECT

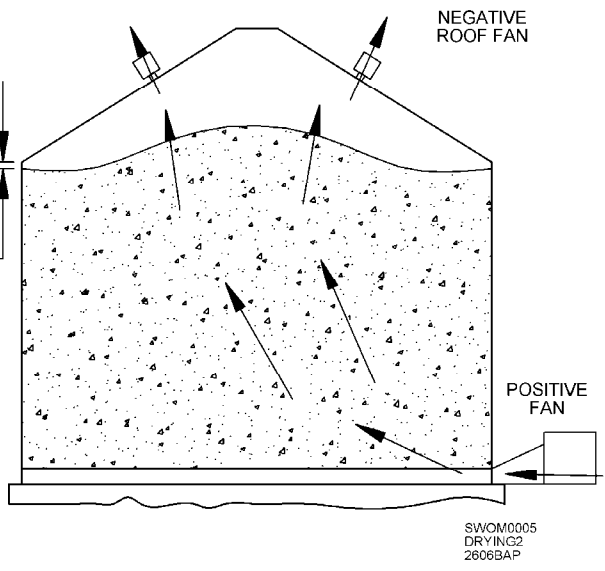

SWOM0005
DRY/INC2
2606BAP

NOTICE: To prevent roof cave-ins, fans should be wired so negative air pressure (suction) roof fans start a few seconds after positive fan. This is done so air has enough time to be pushed through grain to replace air that leaves through roof. Failure to do this could result in roof failure.

ALL

Temperature Cables

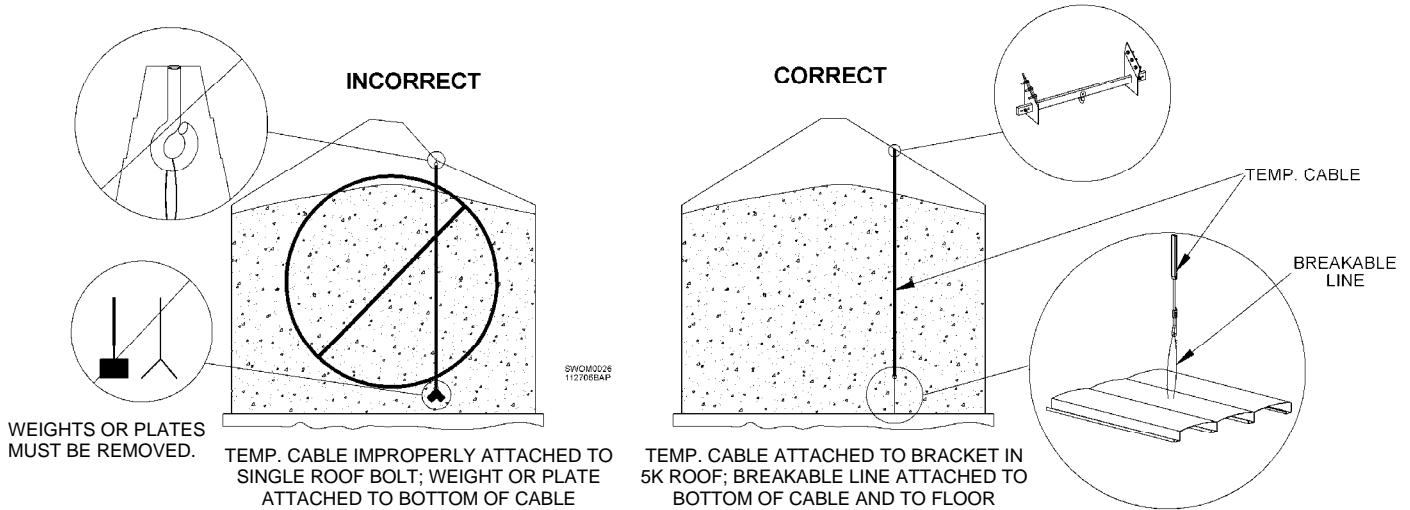

See roof section of Sukup bin erection manual for temperature cable installation instructions and support requirements. Also see temperature cable manufacturer's specifications. Cables are attached to brackets that are attached to two roof ribs on a 5K roof or to rafters on a 15K to 50K roof. **IMPORTANT:** Closed-loop eyebolts are required with use of temperature cable attachment brackets. **NOTICE: Improper installation of temperature cables may cause damage to roof due to down-pull when filling, settling or emptying of grain.** Tie cables to floor or concrete with breakable string (fishing line). **Absolutely NO weights or plates should be attached to bottoms of temperature cables.** For hopper bins, DO NOT allow temperature cables to extend into hopper area. See illustrations above.

Additional Loads

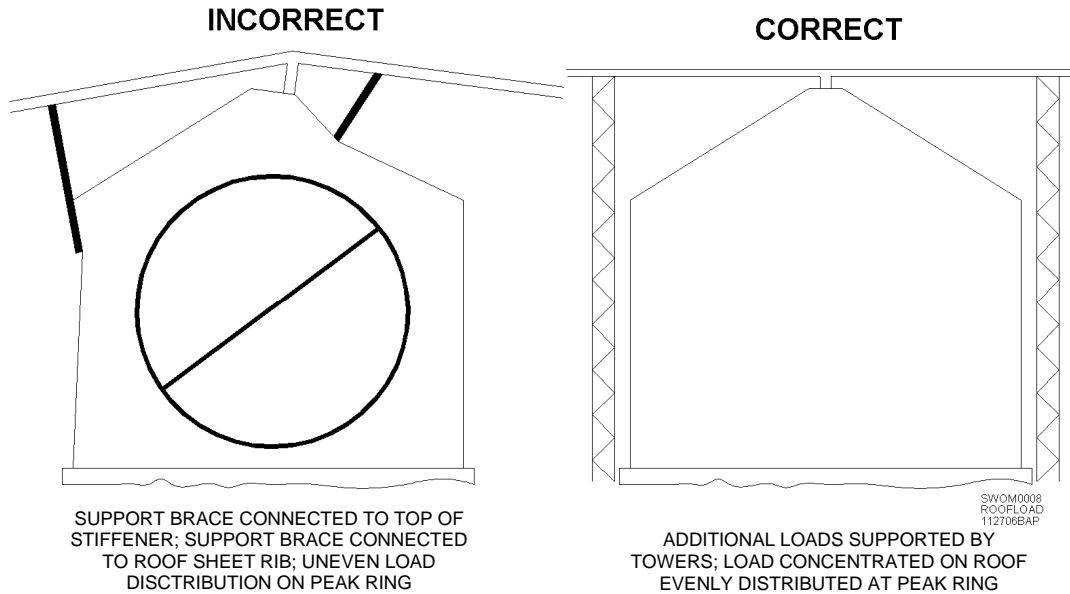

IMPORTANT: Loads created by additional components must not exceed bin design rating. Load ratings for standard Sukup bins are listed on cover sheet of bin price pages. Ratings for special Sukup Commercial bins are specified on quotation form. **All concentrated loads on roof must be UNIFORMLY DISTRIBUTED on peak ring.** Use of separate support towers may be needed to properly distribute overhead loads. **Extra loads should NOT be attached directly to a sidewall stiffener unless specifically designed for the application.** Due to settling, any connections made to bin must contain a properly designed slip joint. Components added incorrectly could cause structural damage to bin and void all warranties.

Stiffener Loads

INCORRECTLY INSTALLED

1. Gaps between stiffeners
2. Sidewall buckling
3. Stiffeners not resting on floor
4. Concrete not level

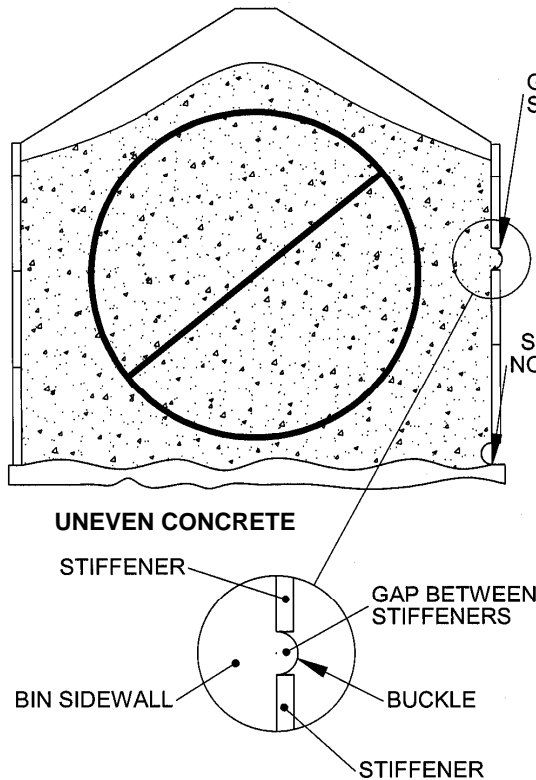

CORRECTLY INSTALLED

1. No gaps between stiffeners
2. No buckling
3. Stiffeners resting flat on floor
4. Level concrete

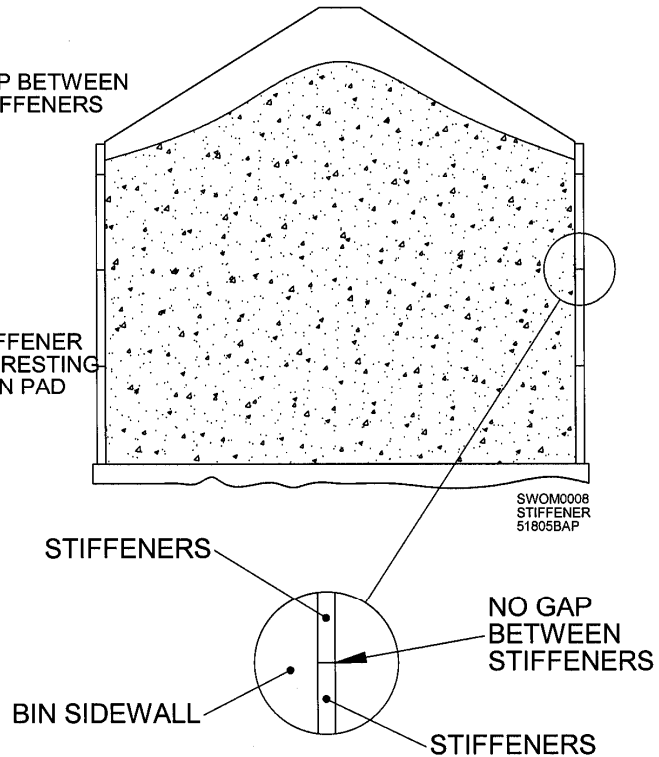

Stiffeners carry vertical load on bin wall, therefore serve as structural columns. They should be attached to sidewall and each other exactly as described in Sukup bin erection manual. They must form a continuous column from eave to concrete floor. Do not cut stiffeners for any reason. There should be no more than a 1/16" gap between stiffeners before initial fill.

If a fan transition would interfere with stiffener, relocate transition so it fits between stiffeners.

If a stiffener location is over a tunnel, alternative support must be provided. Weld square or round tube, minimum 3" wide, directly under stiffener column, with bottom of tube resting on concrete.

It is very important that bottom stiffener rest on concrete pad. Use shims to ensure there is no gap.

Depending on size and diameter of bin, stiffeners may need to be laminated (two continuous columns of stiffeners; one against sidewall and the other against the first). Laminated stiffeners will have staggered seams and no splice plates. See Sukup bin erection manual and color chart for proper assembly instructions.

Sidedraw

OFF-CENTER UNLOADING THROUGH SIDEWALL

NOTICE: Use only Sukup-designed sidedraw discharge units and interior baffles with Sukup bins. Baffles help channel grain to discharge chute as grain flows from above. Never change function of a bin's intended use. Sukup bins are designed for specific amounts of grain and weight and to be loaded and unloaded in a certain manner. If bin was not intended for a sidedraw, unloading pressures may cause bin failure. Know the purpose for which bin was constructed.

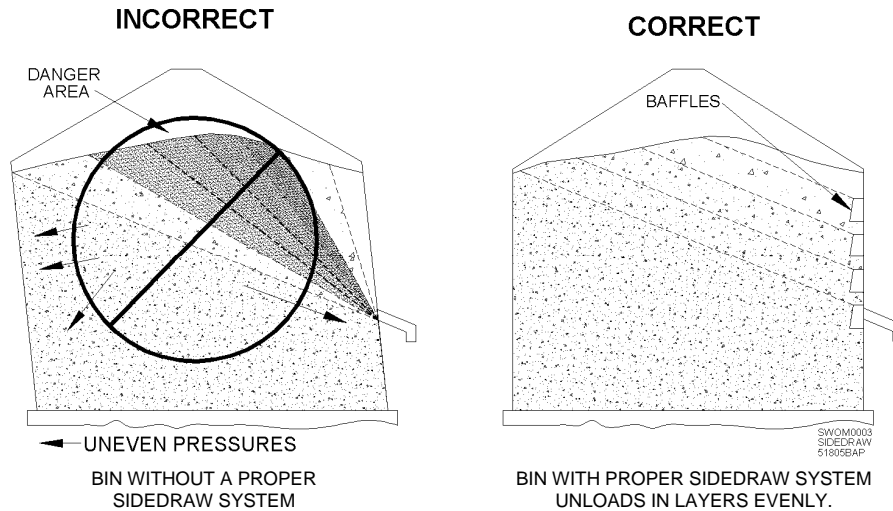

NOTICE: Do not unload bin from sidewall without proper installation of a sidedraw system. Follow special guidelines below for bins with sidedraws. Failure to do so will result in excessive pressures that can result in sidewall leaning, buckling or other bin failure.

IMPORTANT GUIDELINES FOR SIDEDRAW USE

- Never add sidedraw to existing bin without consulting an independent engineer or obtaining written approval from Sukup Manufacturing Co. Bin may not be designed to accommodate a sidedraw.
- Intended for use with dry grain only. Do not use sidedraw with poorly flowing grain products.
- Do not use sidedraw until 90 days after first complete filling.
- Sidedraw must be at least 90° from any door that uses pegs to help secure inner door.
- If two sidedraws are installed, they must be placed at least 90° from one another in same ring. On a 105' bin, they must be placed 180° from each other in same ring.
- Only one sidedraw may be used at a time.
- Sidedraws are not to be used as primary outlets. Standard center sumps and conveyors should be installed. After sidedraw use, unload from center sump, then intermediate sumps, and then sweep bin.
- Do not unload from sidedraw and center sump at same time.
- Do not simultaneously fill and discharge.
- Sidedraw will leave grain in sloped position, creating off-center load. **IMPORTANT:** Before refilling, unload through center sump so grain reaches equal wall heights around entire bin. Grain must be level or in cone-down position before adding more grain. See next page.
- Sidedraw must be installed in center of a sidewall sheet that is no lower than fifth ring from bottom.
- Top discharge baffle must straddle horizontal seam between first and second rings from top of bin.
- Alternate usage of sidedraws in bins 105' in diameter to reduce stress on bin. It is best to unload no more than four (4) rings of grain before switching to other sidedraw. Use illustration at right as a guide.

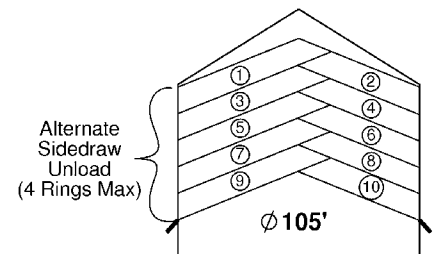

SWBC0137
12/6/2011BAP

COMM.**Refilling after Sidedraw Use**

Before a bin can be refilled after being even partially unloaded with a sidedraw, grain must be leveled or completely emptied through center sump. **It is important that sidewall pressure is equal before refilling.** Unload grain through center sump until grain reaches equal wall heights and an inverted cone is formed in remaining grain. Once an inverted cone is achieved and sidewall pressures are equal, it is safe to refill bin through center peak ring. See drawings below.

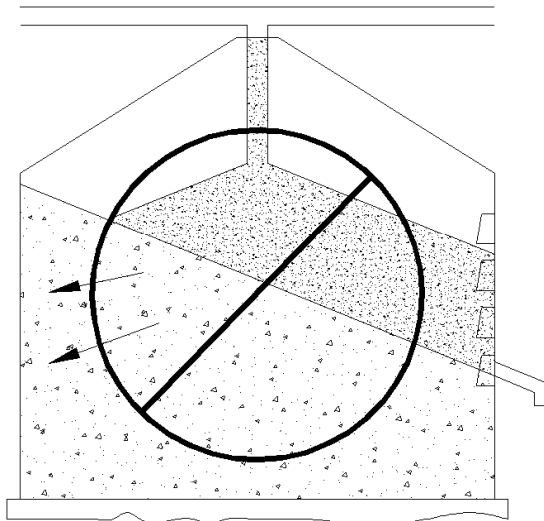
INCORRECT

LOADING WITHOUT LEVELING OR EMPTYING GRAIN IN CONE-DOWN POSITION WILL CREATE UNEVEN SIDEWALL PRESSURES AND MAY CAUSE BIN FAILURE.

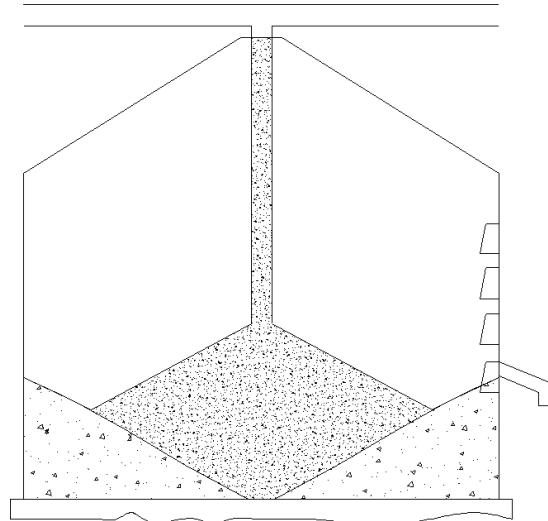
CORRECT

BEFORE REFILLING AFTER SIDEDRAW USE, EMPTY THROUGH CENTER SUMP UNTIL INVERTED CONE IS ACHIEVED AND SIDEWALL PRESSURES ARE EQUAL. REFILL THROUGH CENTER PEAK RING.

NOTE: Design of baffles shown above can be used only with a sidedraw system. Intermediate sumps cannot be used as primary outlet. Unloading must be done through sidedraw, center sump and then intermediate sumps. **NOTICE: Never use intermediate sumps until all grain has flowed by gravity through center sump. Unloading through intermediate sumps initially will cause uneven load distribution that may cause bin damage or failure.**

Before a bin can be refilled, it should be completely emptied. Total cleanout of bin prevents build-up of compacted grain that cannot be emptied by gravity flow. Also, be certain no grain is matted to sidewall. If matting occurs, remove any moldy grain with a wire brush and repaint. Since grain cannot be completely emptied using sidedraw, grain must be emptied through center sump to form an inverted cone in remaining grain. Formation of inverted cone will help evenly distribute lateral forces on bin sidewalls.

HOPPER

Hopper Bins

IMPORTANT: Hopper bins are not intended for drying. Grain should be dry and cool when put in a hopper bin for storage. Maximum allowable storage time for wet grain (over 16%) in a hopper bin may be only one to two days. Storing high-moisture or spoiled grains may deteriorate galvanized coating of bin. High-moisture grain may also cause grain to crust. Probe stored grain regularly to check its quality. Store only free-flowing material. Do not store hard-to-flow material such as soybean meal or other materials that will cake or crust. **NOTICE:** Unloading spoiled grain that is bridged or vertically crusted at a high rate of speed may cause uneven pressures resulting in hopper tank failure. Check inside of bin while unloading to ensure no vertical crusting is evident.

Approximate unloading capacities of hopper gates are based on clean, dry, free-flowing corn.

For standard 16" dia. gate: 19,000 BPH.

For optional 22" dia. gate: 40,000 BPH.

If using 22" dia. gate for commodities heavier than 40 lbs./ft.³, bin may require roof vents and heavier sidewalls. Contact Sukup Manufacturing Co. for special quote.

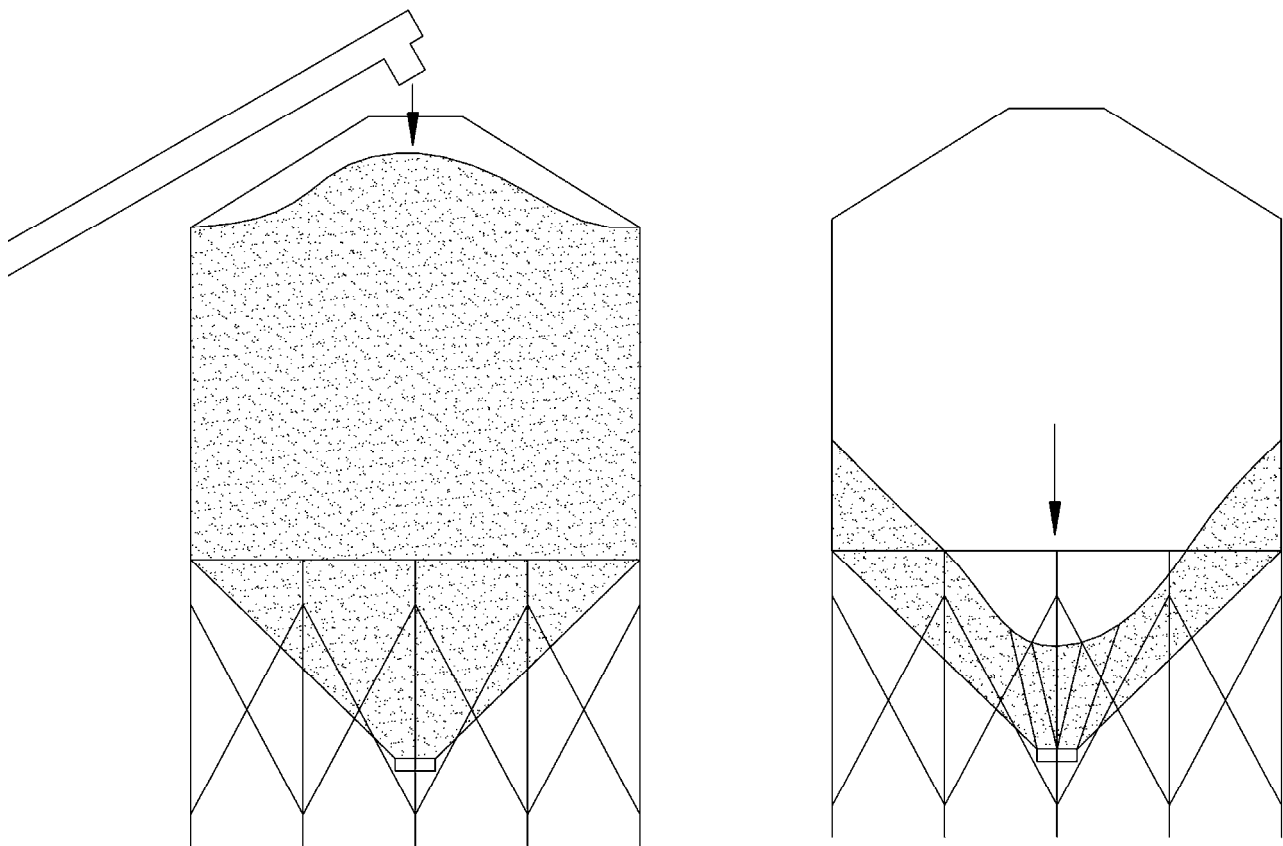

SWOM0010
3606BAP

Before filling hopper bin, be certain no objects or old grain remain inside. Thoroughly clean hopper bottom after each use and be certain bottom unload gate is completely closed. Keep all persons out of bin except when absolutely necessary. Refer to safety section for general guidelines on entering bins, ventilation, and using safety harnesses.

Loading must be done through peak ring. Off-center filling may cause excessive loads, which may result in bin leaning and/or sidewall stiffener buckling. Unloading must be done through outlet cone only. **NOTICE: Never cut holes in bin sidewall.** Off-center unloading will result in excessive down pressure and uneven load distribution that may cause sidewall buckling. **Also, if hopper bin is sealed tight at eave, peak ring cap and manhole must be opened when unloading grain.** Lack of proper roof openings for rapid unloading can cause roof to be pulled down.

Foundation Recommendations for Sukup Grain Bins

Site Selection

When selecting a site for grain storage and handling, many factors need to be considered. Site must allow convenient access for loading, unloading and related work if site is to become a grain system center.

Site should have soil that is firm, level and free of vegetation and underlying debris. Any added fill should be thoroughly compacted to prevent uneven settlement from bin weight.

Locations of handling equipment, fans, heaters, ladders and stairways, etc., must be predetermined. Future expansion should be factored into site selection process, and careful consideration must be paid to access to electrical and gas lines, and to maintaining safe distances from power supply sources.

Electrical Clearances

Check with local electric utility for assistance in planning a safe grain storage and handling site. State codes may vary on clearances. To prevent overhead electrical safety issues, bury electrical lines.

American National Standards Institute (ANSI) provides safety recommendation for grain bins in ANSI C7 1997. Figures 1 and 2 show clearances for bins and grain handling equipment.

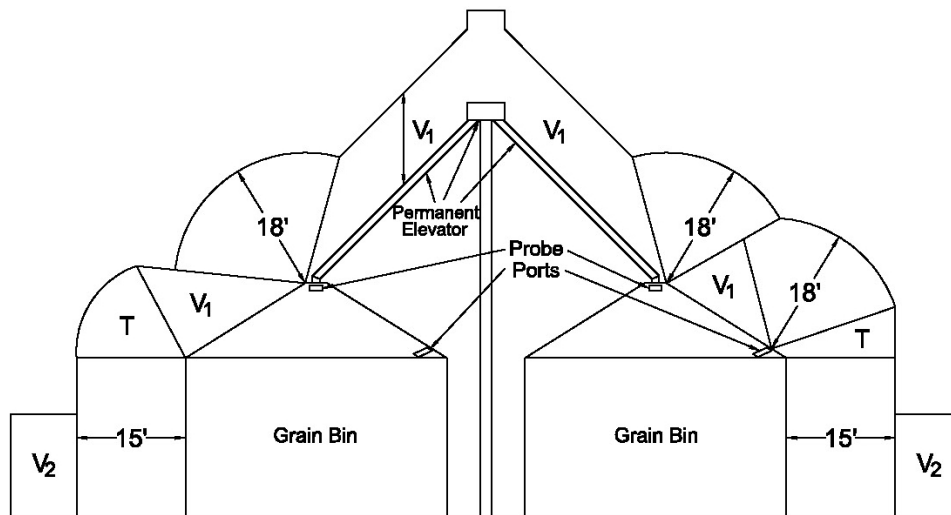

V_1 = Vertical clearance above a building required by Rule 234C (Table 234-1)

V_2 = Vertical clearance above land required by Rule 232

T = Transition clearance

Fig. 1 – Clearances for grain bins filled by permanently installed augers, conveyers or elevators. (ANSI C7 1997)

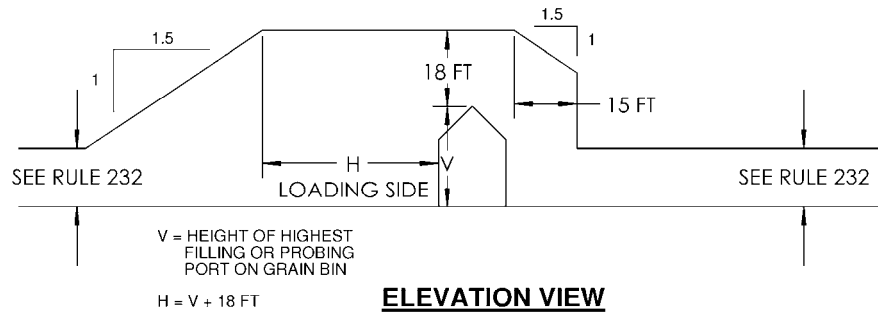
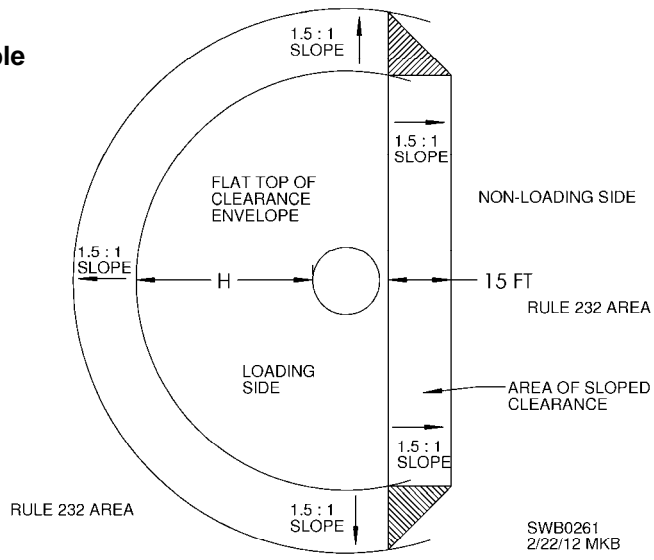

Fig. 2 -- Clearances for grain bins filled by portable augers, conveyors or elevators. (ANSI C7 1997)



Accessory Location

It is important that all components of grain bin be located properly to maximize efficiency and effectiveness of equipment. Most factors should be considered before foundation is poured. Double-check desired location of roof manhole, sidewall and roof ladders, eave platform(s), and walkway(s). Below is a typical layout.

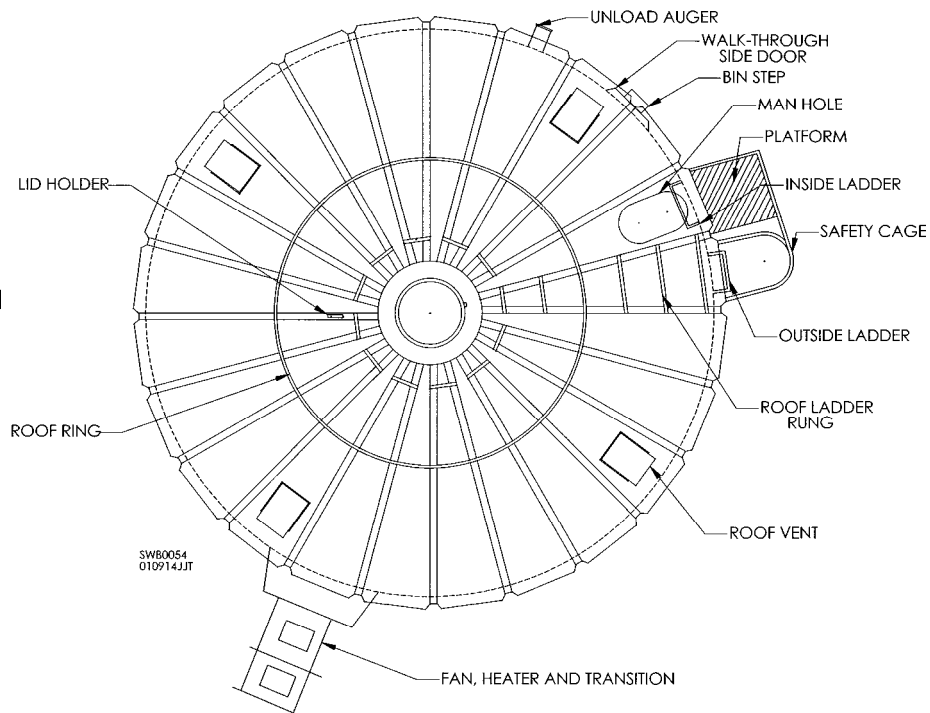

Fig. 3 – Suggested layout of bin components

Foundation Preparation Recommendations

DISCLAIMER: Sukup Manufacturing Co. assumes no responsibility regarding the foundation specifications. This is not an engineered foundation and shall not be constructed as such. The specifications given are intended for quoting and estimating purposes only. It shall be the sole responsibility of the customer to obtain actual foundation drawings designed by and constructed to the specifications of a licensed professional structural engineer with knowledge of the actual soil and load specific to the project and location. Consideration should also include, but not be limited to, live loads, dead loads, wind loads, soil bearing loads, seismic zone, proper moisture run-off on top of base, and types of aeration applied for the project.

Sukup Manufacturing Co. will not be responsible for any damage to a product, including, but not limited to, any damage that results from poor soil conditions or inadequate concrete type, grade, bearing strength, and construction method. Soil bearing tests must be performed by a competent, independent, engineering firm. Concrete foundation construction must be done by a competent, concrete contractor.

Check local and/or regional building codes and regulations to ensure compliance.

Sukup Manufacturing Co. provides foundation data based on 3,000 psf bearing capacity.

All backfill material used in foundation preparations should be clean, crushed stone or sand/gravel mixture of a highly compactable material. Backfill should be layered up in 6" lifts and well compacted.

Concrete Specifications

Cement is to be Type 1 Portland Cement that conforms to ASTM C150.

Maximum aggregate size is to be 3/4 of minimum clear spacing between reinforcing bars and/or wire mesh.

Concrete must be 3,000 psi compressive strength at 28 days cured minimum.

Concrete is to be cured at 50°F and kept moist for a minimum of seven (7) days.

Foundation surface should not vary from level by more than 1/4" in 10 feet or more than 1/4" from specified elevation. Uneven surface may cause bin failure.

Elevation of surface above grade should not exceed 6".

A beveled edge around foundation allows water to run off of surface.

Reinforcing Steel

Steel reinforcing bar (rebar) should conform to ASTM A615 or ASTM A617 and be Grade 60 or better.

To properly size diameter of rebar for specific bin size, consult bin specifications chart.

All circumferential bar laps should be 35 bar diameters and staggered by 3' minimum.

All laps of circumferential bar (rebar) should be bound by either wire tie or welded. Number 6 (6" x 6") wire mesh may be used. Overlap of wire mesh should be 6 inches minimum.

Anchor Bolts

Follow specifications on subsequent pages for appropriate size foundation and anchor bolts.

Foundation Construction Procedure (Monolithic Type)

1. Determine center of foundation. Set a center stake. It can be anything from a simple 2" x 4" to a solid steel stake. In any case, a pivot point must be established from which outside radius can be marked.
2. Attach a straight 2" x 4" board or steel tube to center stake. Attachment must be two feet longer than radius of bin. Adjust so bottom of board is same as desired height of floor surface. Attach so device can swivel 360 degrees unobstructed and remain at desired height. **TIP:** Use a stout enough device that can be used as a concrete leveler later when concrete is poured. See Fig. 4.

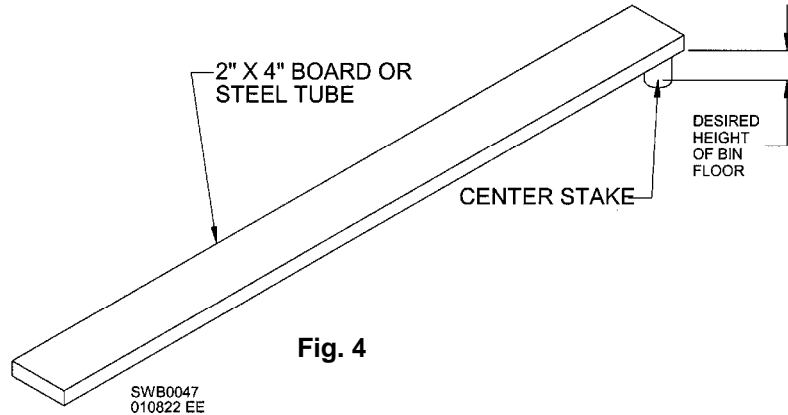

3. Determine radius of bin from center stake and mark on board or steel tube. Attach a second pointed stake to board so it can be used to scribe radius of bin foundation. See Fig. 5.

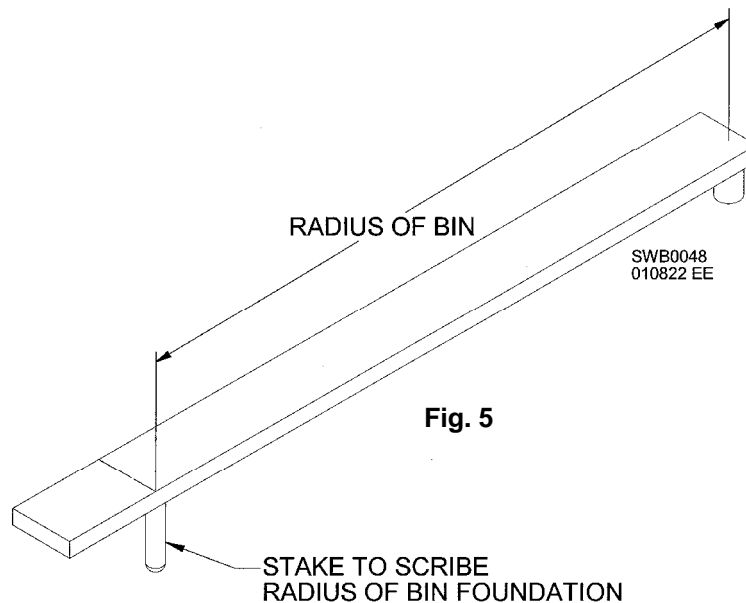

4. Dig footings for foundation per specifications given in foundation chart.

5. Place backfill using 6" lifts. Compact well. Board can be used to level backfill. Measure from bottom of board to determine proper thickness of floor, as specified.
6. Set forms, ensuring they are level and sturdy.
7. Lay steel rebar laterally into footings as specified. Follow overlap procedures outlined in **Reinforcing Steel** guidelines.
8. Lay steel wire mesh in floor area if specified.
9. Lay steel rebar radially in floor area if specified.
10. Wet sand/gravel and pour concrete.
11. Anchor bolts can be placed into concrete when concrete is wet or after concrete has cured. For wet concrete installation, follow instructions 12 through 14. Otherwise skip to 15.
12. Consult foundation specifications table for anchor bolt placement and chord dimensions.

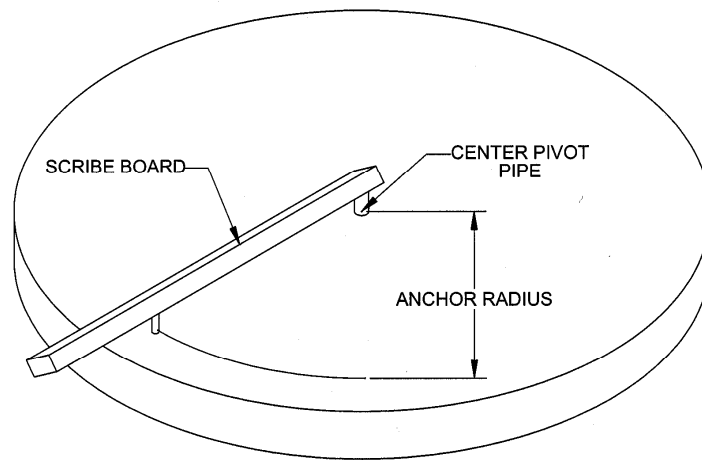

SWB0001
010220 EAE

Fig. 6

13. Using center stake and scribe board, scribe anchor bolt radius into wet concrete. See Fig. 6.
14. Place foundation anchor bolts into concrete while concrete is workable.
15. Anchor bolts may be placed after concrete has cured by drilling holes on concrete and placing bolts with an anchoring adhesive material such as epoxy. Epoxy adhesive should comply with ASTM C881, two-component material suitable for use on dry and damp surfaces. All surfaces must be clean, dry and free of all dust and debris. Clearly mark all areas to be anchored. Drill holes in concrete and inject epoxy adhesive according to manufacturer's specifications. Insert anchor bolt fully into hole and remove excess adhesive. Rebar or plate cutters may be used accordingly when rebar is in the way. Inspect all anchor locations after adhesive has cured.

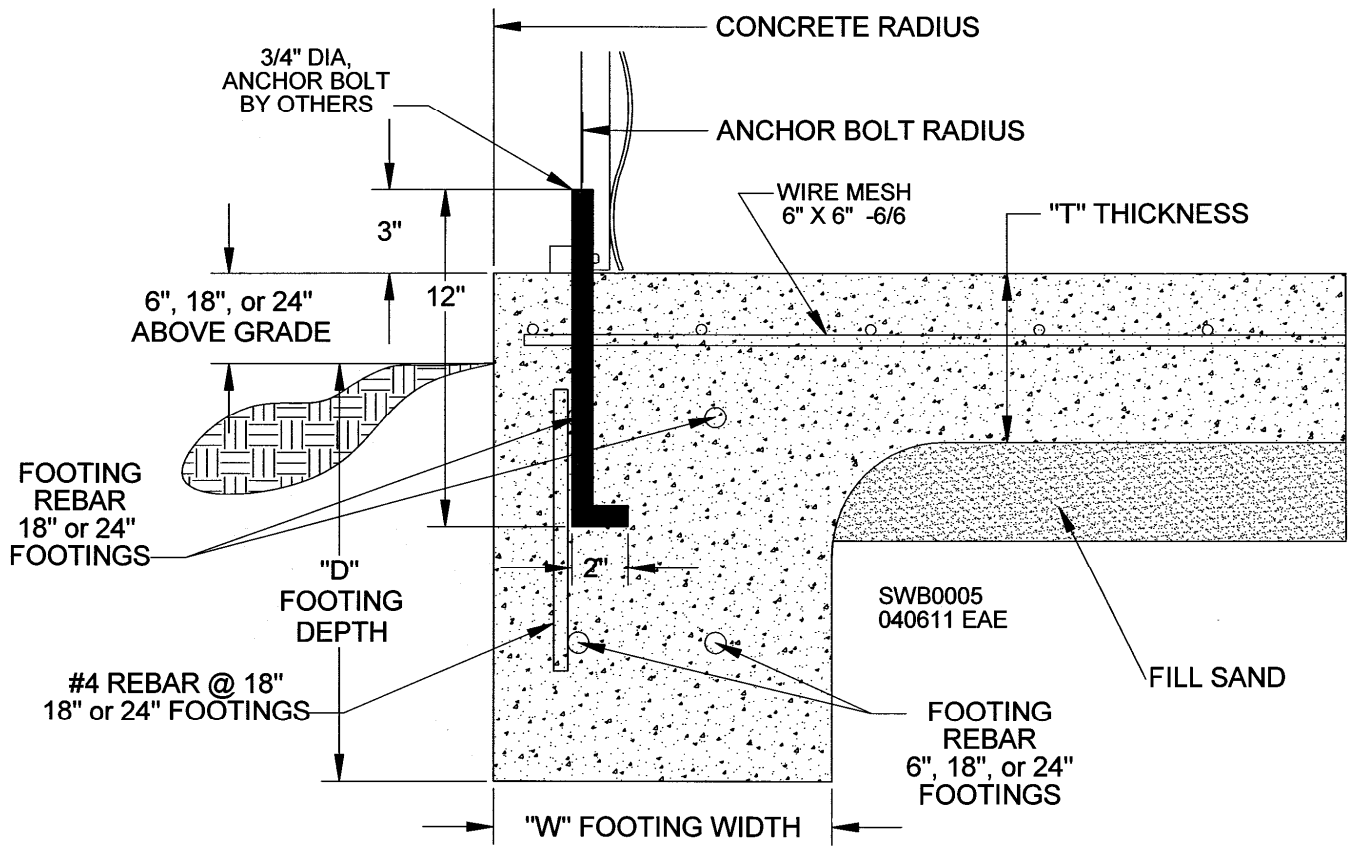

Fig. 7

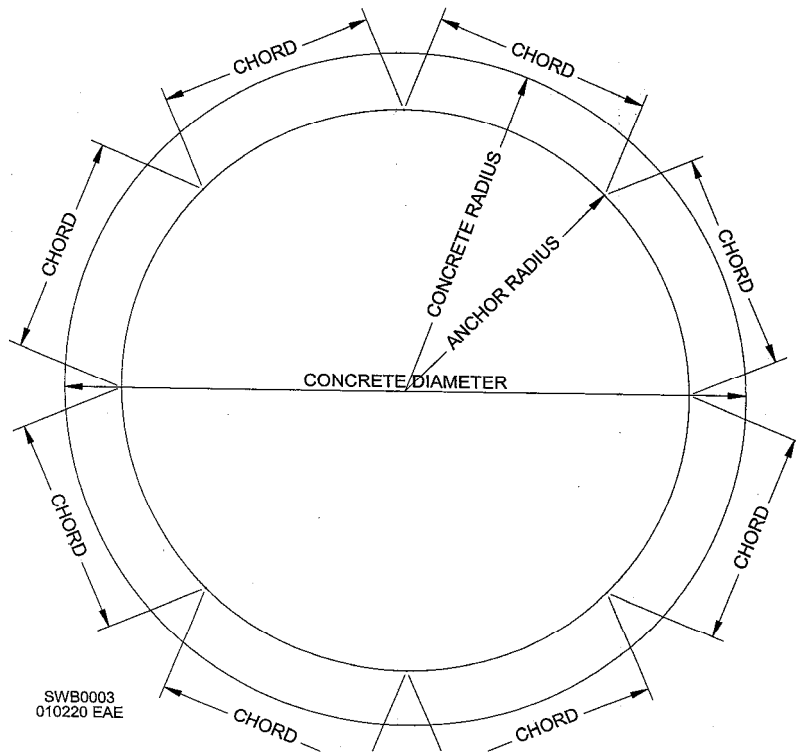

Fig. 8

| Model | Nom. Bin Diam. | Concrete | | Anchor | | | 6" Above Grade | | | | | | | | |
|-------|----------------|------------|------------|-------------|------------|-------|----------------|-----|-----|-----------------|-----------------|------------------|-----|------|--------|
| | | Diameter | Radius | Radius | Chord | Total | T | D | W | Footing Rebar | | | | | |
| | | | | | | | | | | Concrete cu yds | Wire Mesh sq ft | Fill Sand cu yds | Qty | Size | Lin Ft |
| 1503 | 15' | 16' 5 1/8" | 8' 2 9/16" | 7' 8 19/32" | 4' 9 7/32" | 10 | 5" | 12" | 12" | 5 | 221 | 3 | 2 | 4 | 100 |
| 1504 | 15' | 16' 5 1/8" | 8' 2 9/16" | 7' 8 19/32" | 4' 9 7/32" | 10 | 5" | 12" | 12" | 5 | 221 | 3 | 2 | 4 | 100 |
| 1505 | 15' | 16' 5 1/8" | 8' 2 9/16" | 7' 8 19/32" | 4' 9 7/32" | 10 | 5" | 12" | 12" | 5 | 221 | 3 | 2 | 4 | 100 |
| 1506 | 15' | 16' 5 1/8" | 8' 2 9/16" | 7' 8 19/32" | 4' 9 7/32" | 10 | 5" | 12" | 12" | 5 | 221 | 3 | 2 | 4 | 100 |
| 1507 | 15' | 16' 5 1/8" | 8' 2 9/16" | 7' 8 19/32" | 4' 9 7/32" | 10 | 5" | 12" | 12" | 5 | 221 | 3 | 2 | 4 | 100 |
| 1508 | 15' | 16' 5 1/8" | 8' 2 9/16" | 7' 8 19/32" | 4' 9 7/32" | 10 | 5" | 12" | 18" | 6 | 221 | 3 | 2 | 4 | 100 |
| 1509 | 15' | 16' 5 1/8" | 8' 2 9/16" | 7' 8 19/32" | 4' 9 7/32" | 10 | 5" | 12" | 18" | 6 | 221 | 3 | 2 | 5 | 102 |
| 1510 | 15' | 16' 5 1/8" | 8' 2 9/16" | 7' 8 19/32" | 4' 9 7/32" | 10 | 5.5" | 12" | 24" | 7 | 221 | 2 | 2 | 5 | 102 |
| 1511 | 15' | 16' 5 1/8" | 8' 2 9/16" | 7' 8 19/32" | 4' 9 7/32" | 10 | 5.5" | 12" | 24" | 7 | 221 | 2 | 3 | 4 | 150 |
| 1512 | 15' | 16' 7 1/8" | 8' 3 9/16" | 7' 8 19/32" | 4' 9 7/32" | 10 | 5.5" | 12" | 30" | 8 | 221 | 2 | 3 | 4 | 150 |
| 1803 | 18' | 19' 5" | 9' 8 1/2" | 9' 2 1/2" | 4' 9 3/16" | 12 | 5" | 12" | 12" | 7 | 312 | 4 | 2 | 4 | 119 |
| 1804 | 18' | 19' 5" | 9' 8 1/2" | 9' 2 1/2" | 4' 9 3/16" | 12 | 5" | 12" | 12" | 7 | 312 | 4 | 2 | 4 | 119 |
| 1805 | 18' | 19' 5" | 9' 8 1/2" | 9' 2 1/2" | 4' 9 3/16" | 12 | 5" | 12" | 12" | 7 | 312 | 4 | 2 | 4 | 119 |
| 1806 | 18' | 19' 5" | 9' 8 1/2" | 9' 2 1/2" | 4' 9 3/16" | 12 | 5" | 12" | 12" | 7 | 312 | 4 | 2 | 4 | 119 |
| 1807 | 18' | 19' 5" | 9' 8 1/2" | 9' 2 1/2" | 4' 9 3/16" | 12 | 5" | 12" | 18" | 8.5 | 312 | 3 | 2 | 4 | 119 |
| 1808 | 18' | 19' 5" | 9' 8 1/2" | 9' 2 1/2" | 4' 9 3/16" | 12 | 5" | 12" | 18" | 8.5 | 312 | 3 | 2 | 4 | 119 |
| 1809 | 18' | 19' 5" | 9' 8 1/2" | 9' 2 1/2" | 4' 9 3/16" | 12 | 5" | 12" | 18" | 8.5 | 312 | 3 | 2 | 5 | 120 |
| 1810 | 18' | 19' 5" | 9' 8 1/2" | 9' 2 1/2" | 4' 9 3/16" | 12 | 5.5" | 12" | 24" | 9.5 | 312 | 3 | 2 | 5 | 120 |
| 1811 | 18' | 19' 5" | 9' 8 1/2" | 9' 2 1/2" | 4' 9 3/16" | 12 | 5.5" | 12" | 24" | 9.5 | 312 | 3 | 3 | 4 | 178 |
| 1812 | 18' | 19' 7" | 9' 9 1/2" | 9' 2 1/2" | 4' 9 3/16" | 12 | 5.5" | 12" | 30" | 10.5 | 312 | 3 | 3 | 4 | 178 |
| 2103 | 21' | 22' 5" | 11' 2 1/2" | 10' 8 3/8" | 4' 9 1/8" | 14 | 5" | 12" | 12" | 9.5 | 418 | 5 | 2 | 4 | 140 |
| 2104 | 21' | 22' 5" | 11' 2 1/2" | 10' 8 3/8" | 4' 9 1/8" | 14 | 5" | 12" | 12" | 9.5 | 418 | 5 | 2 | 4 | 140 |
| 2105 | 21' | 22' 5" | 11' 2 1/2" | 10' 8 3/8" | 4' 9 1/8" | 14 | 5" | 12" | 12" | 9.5 | 418 | 5 | 2 | 4 | 140 |
| 2106 | 21' | 22' 5" | 11' 2 1/2" | 10' 8 3/8" | 4' 9 1/8" | 14 | 5" | 12" | 12" | 9.5 | 418 | 5 | 2 | 4 | 140 |
| 2107 | 21' | 22' 5" | 11' 2 1/2" | 10' 8 3/8" | 4' 9 1/8" | 14 | 5" | 12" | 18" | 10.5 | 418 | 5 | 2 | 4 | 140 |
| 2108 | 21' | 22' 5" | 11' 2 1/2" | 10' 8 3/8" | 4' 9 1/8" | 14 | 5" | 12" | 18" | 10.5 | 418 | 5 | 2 | 5 | 142 |
| 2109 | 21' | 22' 5" | 11' 2 1/2" | 10' 8 3/8" | 4' 9 1/8" | 14 | 5" | 12" | 18" | 10.5 | 418 | 5 | 2 | 5 | 142 |
| 2110 | 21' | 22' 5" | 11' 2 1/2" | 10' 8 3/8" | 4' 9 1/8" | 14 | 5.5" | 12" | 24" | 12 | 418 | 4 | 3 | 4 | 208 |
| 2111 | 21' | 22' 6" | 11' 3" | 10' 8 3/8" | 4' 9 1/8" | 14 | 5.5" | 12" | 30" | 13 | 418 | 4 | 3 | 4 | 208 |
| 2112 | 21' | 22' 8" | 11' 4" | 10' 8 3/8" | 4' 9 1/8" | 14 | 5.5" | 12" | 30" | 13 | 418 | 4 | 3 | 4 | 208 |
| 2403 | 24' | 25' 4" | 12' 8" | 12' 2 5/16" | 4' 9 1/16" | 16 | 5" | 12" | 12" | 11.5 | 540 | 7 | 2 | 4 | 157 |
| 2404 | 24' | 25' 4" | 12' 8" | 12' 2 5/16" | 4' 9 1/16" | 16 | 5" | 12" | 12" | 11.5 | 540 | 7 | 2 | 4 | 157 |
| 2405 | 24' | 25' 4" | 12' 8" | 12' 2 5/16" | 4' 9 1/16" | 16 | 5" | 12" | 12" | 11.5 | 540 | 7 | 2 | 4 | 157 |
| 2406 | 24' | 25' 4" | 12' 8" | 12' 2 5/16" | 4' 9 1/16" | 16 | 5" | 12" | 12" | 11.5 | 540 | 7 | 2 | 4 | 157 |
| 2407 | 24' | 25' 4" | 12' 8" | 12' 2 5/16" | 4' 9 1/16" | 16 | 5" | 12" | 18" | 13 | 540 | 6 | 2 | 5 | 159 |
| 2408 | 24' | 25' 4" | 12' 8" | 12' 2 5/16" | 4' 9 1/16" | 16 | 5" | 12" | 18" | 13 | 540 | 6 | 2 | 5 | 159 |
| 2409 | 24' | 25' 4" | 12' 8" | 12' 2 5/16" | 4' 9 1/16" | 16 | 5" | 12" | 24" | 15 | 540 | 6 | 2 | 5 | 159 |
| 2410 | 24' | 25' 4" | 12' 8" | 12' 2 5/16" | 4' 9 1/16" | 16 | 5.5" | 12" | 24" | 15 | 540 | 6 | 3 | 4 | 224 |
| 2411 | 24' | 25' 6" | 12' 9" | 12' 2 5/16" | 4' 9 1/16" | 16 | 5.5" | 12" | 30" | 16.5 | 540 | 6 | 3 | 4 | 224 |
| 2412 | 24' | 25' 8" | 12' 10" | 12' 2 5/16" | 4' 9 1/16" | 16 | 5.5" | 12" | 36" | 18 | 540 | 6 | 3 | 5 | 227 |
| 2703 | 27' | 28' 4" | 14' 2" | 13' 8 3/16" | 4' 9 1/16" | 18 | 5" | 12" | 12" | 14.5 | 677 | 8 | 2 | 4 | 179 |
| 2704 | 27' | 28' 4" | 14' 2" | 13' 8 3/16" | 4' 9 1/16" | 18 | 5" | 12" | 12" | 14.5 | 677 | 8 | 2 | 4 | 179 |
| 2705 | 27' | 28' 4" | 14' 2" | 13' 8 3/16" | 4' 9 1/16" | 18 | 5" | 12" | 12" | 14.5 | 677 | 8 | 2 | 4 | 179 |
| 2706 | 27' | 28' 4" | 14' 2" | 13' 8 3/16" | 4' 9 1/16" | 18 | 5" | 12" | 12" | 14.5 | 677 | 8 | 2 | 4 | 179 |
| 2707 | 27' | 28' 4" | 14' 2" | 13' 8 3/16" | 4' 9 1/16" | 18 | 5.5" | 12" | 18" | 16 | 677 | 8 | 2 | 5 | 182 |
| 2708 | 27' | 28' 4" | 14' 2" | 13' 8 3/16" | 4' 9 1/16" | 18 | 5.5" | 12" | 18" | 16 | 677 | 8 | 2 | 5 | 182 |
| 2709 | 27' | 28' 4" | 14' 2" | 13' 8 3/16" | 4' 9 1/16" | 18 | 5.5" | 12" | 24" | 18 | 677 | 8 | 2 | 5 | 182 |
| 2710 | 27' | 28' 4" | 14' 2" | 13' 8 3/16" | 4' 9 1/16" | 18 | 5.5" | 12" | 24" | 18 | 677 | 7 | 3 | 5 | 270 |
| 2711 | 27' | 28' 6" | 14' 3" | 13' 8 3/16" | 4' 9 1/16" | 18 | 5.5" | 12" | 30" | 19.5 | 677 | 7 | 3 | 5 | 270 |
| 2712 | 27' | 28' 8" | 14' 4" | 13' 8 3/16" | 4' 9 1/16" | 18 | 5.5" | 12" | 36" | 21 | 677 | 7 | 3 | 5 | 270 |
| 3003 | 30' | 31' 4" | 15' 8" | 15' 2 1/8" | 4' 9" | 20 | 5" | 12" | 12" | 17 | 830 | 10 | 2 | 4 | 197 |
| 3004 | 30' | 31' 4" | 15' 8" | 15' 2 1/8" | 4' 9" | 20 | 5" | 12" | 12" | 17 | 830 | 10 | 2 | 4 | 197 |
| 3005 | 30' | 31' 4" | 15' 8" | 15' 2 1/8" | 4' 9" | 20 | 5" | 12" | 12" | 17 | 830 | 10 | 2 | 4 | 197 |
| 3006 | 30' | 31' 4" | 15' 8" | 15' 2 1/8" | 4' 9" | 20 | 5" | 12" | 12" | 17 | 830 | 10 | 2 | 4 | 197 |
| 3007 | 30' | 31' 4" | 15' 8" | 15' 2 1/8" | 4' 9" | 20 | 5.5" | 12" | 18" | 19 | 830 | 10 | 2 | 5 | 200 |
| 3008 | 30' | 31' 4" | 15' 8" | 15' 2 1/8" | 4' 9" | 20 | 5.5" | 12" | 18" | 19 | 830 | 10 | 2 | 5 | 200 |
| 3009 | 30' | 31' 4" | 15' 8" | 15' 2 1/8" | 4' 9" | 20 | 5.5" | 12" | 24" | 21 | 830 | 10 | 2 | 5 | 200 |
| 3010 | 30' | 31' 4" | 15' 8" | 15' 2 1/8" | 4' 9" | 20 | 6" | 12" | 30" | 23 | 830 | 9 | 3 | 5 | 300 |
| 3011 | 30' | 31' 6" | 15' 9" | 15' 2 1/8" | 4' 9" | 20 | 6" | 12" | 30" | 23 | 830 | 9 | 3 | 5 | 300 |
| 3012 | 30' | 31' 8" | 15' 10" | 15' 2 1/8" | 4' 9" | 20 | 6" | 12" | 36" | 25 | 830 | 9 | 3 | 5 | 300 |

| Model | Nom. Bin Diam. | Concrete | | Anchor | | | 6" Above Grade | | | | | | | | | |
|-------|----------------|-------------|-------------|--------------|-------------|-------|----------------|-----|-----|-----------------|-----------------|------------------|---------------|------|--------|--|
| | | Diameter | Radius | Radius | Chord | Total | T | D | W | Concrete cu yds | Wire Mesh sq ft | Fill Sand cu yds | Footing Rebar | | | |
| | | | | | | | | | | | | | Qty | Size | Lin Ft | |
| 3303 | 33' | 34' 4" | 17' 2" | 16' 8" | 4' 8 15/16" | 22 | 5" | 12" | 12" | 20 | 998 | 13 | 2 | 5 | 222 | |
| 3304 | 33' | 34' 4" | 17' 2" | 16' 8" | 4' 8 15/16" | 22 | 5" | 12" | 12" | 20 | 998 | 13 | 2 | 5 | 222 | |
| 3305 | 33' | 34' 4" | 17' 2" | 16' 8" | 4' 8 15/16" | 22 | 5" | 12" | 12" | 20 | 998 | 13 | 2 | 5 | 222 | |
| 3306 | 33' | 34' 4" | 17' 2" | 16' 8" | 4' 8 15/16" | 22 | 5" | 12" | 12" | 20 | 998 | 13 | 2 | 5 | 222 | |
| 3307 | 33' | 34' 4" | 17' 2" | 16' 8" | 4' 8 15/16" | 22 | 5.5" | 12" | 18" | 22.5 | 998 | 12 | 2 | 6 | 225 | |
| 3308 | 33' | 34' 4" | 17' 2" | 16' 8" | 4' 8 15/16" | 22 | 5.5" | 12" | 18" | 22.5 | 998 | 12 | 2 | 6 | 225 | |
| 3309 | 33' | 34' 4" | 17' 2" | 16' 8" | 4' 8 15/16" | 22 | 5.5" | 12" | 24" | 24.5 | 998 | 12 | 2 | 6 | 225 | |
| 3310 | 33' | 34' 4" | 17' 2" | 16' 8" | 4' 8 15/16" | 22 | 6" | 12" | 30" | 27 | 998 | 11 | 3 | 5 | 330 | |
| 3311 | 33' | 34' 6" | 17' 3" | 16' 8" | 4' 8 15/16" | 22 | 6" | 12" | 30" | 27 | 998 | 11 | 3 | 5 | 330 | |
| 3312 | 33' | 34' 8" | 17' 4" | 16' 8" | 4' 8 15/16" | 22 | 6" | 12" | 36" | 29 | 998 | 11 | 3 | 5 | 330 | |
| 3603 | 36' | 37' 4" | 18' 8" | 18' 1 15/16" | 4' 8 7/8" | 24 | 5" | 12" | 12" | 24 | 1182 | 15 | 2 | 5 | 240 | |
| 3604 | 36' | 37' 4" | 18' 8" | 18' 1 15/16" | 4' 8 7/8" | 24 | 5" | 12" | 12" | 24 | 1182 | 15 | 2 | 5 | 240 | |
| 3605 | 36' | 37' 4" | 18' 8" | 18' 1 15/16" | 4' 8 7/8" | 24 | 5" | 12" | 12" | 24 | 1182 | 15 | 2 | 5 | 240 | |
| 3606 | 36' | 37' 4" | 18' 8" | 18' 1 15/16" | 4' 8 7/8" | 24 | 5" | 12" | 12" | 24 | 1182 | 15 | 2 | 5 | 240 | |
| 3607 | 36' | 37' 4" | 18' 8" | 18' 1 15/16" | 4' 8 7/8" | 24 | 5.5" | 12" | 18" | 26 | 1182 | 14 | 2 | 6 | 243 | |
| 3608 | 36' | 37' 4" | 18' 8" | 18' 1 15/16" | 4' 8 7/8" | 24 | 5.5" | 12" | 24" | 28 | 1182 | 14 | 2 | 6 | 243 | |
| 3609 | 36' | 37' 4" | 18' 8" | 18' 1 15/16" | 4' 8 7/8" | 24 | 5.5" | 12" | 24" | 28 | 1182 | 14 | 2 | 6 | 243 | |
| 3610 | 36' | 37' 4" | 18' 8" | 18' 1 15/16" | 4' 8 7/8" | 24 | 6" | 12" | 30" | 31 | 1182 | 13 | 3 | 5 | 355 | |
| 3611 | 36' | 37' 6" | 18' 9" | 18' 1 15/16" | 4' 8 7/8" | 24 | 6" | 12" | 36" | 33 | 1182 | 13 | 3 | 5 | 355 | |
| 3612 | 36' | 37' 8" | 18' 10" | 18' 1 15/16" | 4' 8 7/8" | 24 | 6" | 12" | 36" | 33 | 1182 | 13 | 3 | 6 | 358 | |
| 4203 | 42' | 43' 3" | 21' 7 1/2" | 21' 1 3/4" | 4' 8 13/16" | 28 | 5.5" | 12" | 12" | 31 | 1597 | 21 | 2 | 5 | 280 | |
| 4204 | 42' | 43' 3" | 21' 7 1/2" | 21' 1 3/4" | 4' 8 13/16" | 28 | 5.5" | 12" | 12" | 31 | 1597 | 21 | 2 | 5 | 280 | |
| 4205 | 42' | 43' 3" | 21' 7 1/2" | 21' 1 3/4" | 4' 8 13/16" | 28 | 5.5" | 12" | 12" | 31 | 1597 | 21 | 2 | 5 | 280 | |
| 4206 | 42' | 43' 3" | 21' 7 1/2" | 21' 1 3/4" | 4' 8 13/16" | 28 | 5.5" | 12" | 18" | 34 | 1597 | 20 | 2 | 6 | 283 | |
| 4207 | 42' | 43' 3" | 21' 7 1/2" | 21' 1 3/4" | 4' 8 13/16" | 28 | 5.5" | 12" | 18" | 34 | 1597 | 20 | 2 | 6 | 283 | |
| 4208 | 42' | 43' 3" | 21' 7 1/2" | 21' 1 3/4" | 4' 8 13/16" | 28 | 6" | 12" | 24" | 37 | 1597 | 19 | 3 | 5 | 415 | |
| 4209 | 42' | 43' 3" | 21' 7 1/2" | 21' 1 3/4" | 4' 8 13/16" | 28 | 6" | 12" | 24" | 37 | 1597 | 19 | 3 | 5 | 415 | |
| 4210 | 42' | 44' 3" | 22' 1 7/16" | 21' 1 3/4" | 4' 8 13/16" | 28 | 6" | 12" | 30" | 40 | 1597 | 19 | 3 | 5 | 415 | |
| 4211 | 42' | 44' 3" | 22' 1 7/16" | 21' 1 3/4" | 4' 8 13/16" | 28 | 6" | 12" | 36" | 43 | 1597 | 19 | 3 | 6 | 418 | |
| 4212 | 42' | 44' 3" | 22' 1 7/16" | 21' 1 3/4" | 4' 8 13/16" | 28 | 6" | 18" | 42" | 53 | 1597 | 18 | 3 | 6 | 418 | |
| 4803 | 48' | 49' 3" | 24' 7 1/2" | 24' 1 1/2" | 4' 8 3/4" | 32 | 6" | 12" | 12" | 40 | 2074 | 27 | 2 | 5 | 320 | |
| 4804 | 48' | 49' 3" | 24' 7 1/2" | 24' 1 1/2" | 4' 8 3/4" | 32 | 6" | 12" | 12" | 40 | 2074 | 27 | 2 | 5 | 320 | |
| 4805 | 48' | 49' 3" | 24' 7 1/2" | 24' 1 1/2" | 4' 8 3/4" | 32 | 6" | 12" | 12" | 40 | 2074 | 27 | 2 | 5 | 320 | |
| 4806 | 48' | 49' 3" | 24' 7 1/2" | 24' 1 1/2" | 4' 8 3/4" | 32 | 6" | 12" | 18" | 43.5 | 2074 | 26 | 2 | 6 | 324 | |
| 4807 | 48' | 49' 3" | 24' 7 1/2" | 24' 1 1/2" | 4' 8 3/4" | 32 | 6" | 12" | 18" | 43.5 | 2074 | 26 | 2 | 6 | 324 | |
| 4808 | 48' | 49' 3" | 24' 7 1/2" | 24' 1 1/2" | 4' 8 3/4" | 32 | 6" | 12" | 24" | 46 | 2074 | 25 | 3 | 5 | 480 | |
| 4809 | 48' | 49' 3" | 24' 7 1/2" | 24' 1 1/2" | 4' 8 3/4" | 32 | 6" | 12" | 30" | 49 | 2074 | 25 | 3 | 5 | 480 | |
| 4810 | 48' | 50' 2 7/16" | 25' 1 7/32" | 24' 1 1/2" | 4' 8 3/4" | 32 | 6" | 12" | 30" | 49 | 2074 | 25 | 3 | 5 | 480 | |
| 4811 | 48' | 50' 2 7/16" | 25' 1 7/32" | 24' 1 1/2" | 4' 8 3/4" | 32 | 6" | 12" | 36" | 53 | 2074 | 24 | 3 | 6 | 486 | |
| 4812 | 48' | 50' 2 7/16" | 25' 1 7/32" | 24' 1 1/2" | 4' 8 3/4" | 32 | 6" | 18" | 42" | 65 | 2074 | 24 | 3 | 6 | 486 | |

| Model | Nom. Bin Diam. | Concrete | | Anchor | | | 18" Above Grade | | | | | | | | | | | |
|-------|----------------|------------|------------|-------------|------------|-------|-----------------|-----|-----|-----------------|-----------------|------------------|---------------|------|--------|-------------------|------|--------|
| | | Diameter | Radius | Radius | Chord | Total | T | D | W | Concrete cu yds | Wire Mesh sq ft | Fill Sand cu yds | Footing Rebar | | | Vert Rebar (24"L) | | |
| | | | | | | | | | | | | | Qty | Size | Lin Ft | Qty | Size | Lin Ft |
| 1503 | 15' | 16' 5 1/8" | 8' 2 9/16" | 7' 8 19/32" | 4' 9 7/32" | 10 | 5" | 12" | 12" | 7 | 221 | 3 | 4 | 4 | 200 | 32 | 4 | 64 |
| 1504 | 15' | 16' 5 1/8" | 8' 2 9/16" | 7' 8 19/32" | 4' 9 7/32" | 10 | 5" | 12" | 12" | 7 | 221 | 3 | 4 | 4 | 200 | 32 | 4 | 64 |
| 1505 | 15' | 16' 5 1/8" | 8' 2 9/16" | 7' 8 19/32" | 4' 9 7/32" | 10 | 5" | 12" | 12" | 7 | 221 | 3 | 4 | 4 | 200 | 32 | 4 | 64 |
| 1506 | 15' | 16' 5 1/8" | 8' 2 9/16" | 7' 8 19/32" | 4' 9 7/32" | 10 | 5" | 12" | 12" | 7 | 221 | 3 | 4 | 4 | 200 | 32 | 4 | 64 |
| 1507 | 15' | 16' 5 1/8" | 8' 2 9/16" | 7' 8 19/32" | 4' 9 7/32" | 10 | 5" | 12" | 12" | 7 | 221 | 3 | 4 | 4 | 200 | 32 | 4 | 64 |
| 1508 | 15' | 16' 5 1/8" | 8' 2 9/16" | 7' 8 19/32" | 4' 9 7/32" | 10 | 5" | 12" | 18" | 8.5 | 221 | 3 | 4 | 4 | 200 | 32 | 4 | 64 |
| 1509 | 15' | 16' 5 1/8" | 8' 2 9/16" | 7' 8 19/32" | 4' 9 7/32" | 10 | 5" | 12" | 18" | 8.5 | 221 | 3 | 4 | 5 | 204 | 32 | 4 | 64 |
| 1510 | 15' | 16' 5 1/8" | 8' 2 9/16" | 7' 8 19/32" | 4' 9 7/32" | 10 | 5.5" | 12" | 24" | 10 | 221 | 2 | 4 | 5 | 204 | 32 | 4 | 64 |
| 1511 | 15' | 16' 5 1/8" | 8' 2 9/16" | 7' 8 19/32" | 4' 9 7/32" | 10 | 5.5" | 12" | 24" | 10 | 221 | 2 | 6 | 4 | 300 | 32 | 4 | 64 |
| 1512 | 15' | 16' 7 1/8" | 8' 3 9/16" | 7' 8 19/32" | 4' 9 7/32" | 10 | 5.5" | 12" | 30" | 11.5 | 221 | 2 | 6 | 4 | 300 | 32 | 4 | 64 |

| Model | Nom. Bin Diam. | Concrete | | Anchor | | | | 18" Above Grade | | | | | | | | | | |
|-------|----------------|----------|------------|-------------|-------------|-------|------|-----------------|-----|-----------------|-----------------|------------------|---------------|------|--------|-------------------|------|--------|
| | | Diameter | Radius | Radius | Chord | Total | T | D | W | Concrete cu yds | Wire Mesh sq ft | Fill Sand cu yds | Footing Rebar | | | Vert Rebar (24"L) | | |
| | | | | | | | | | | | | | Qty | Size | Lin Ft | Qty | Size | Lin Ft |
| 1803 | 18' | 19' 5" | 9' 8 1/2" | 9' 2 1/2" | 4' 9 3/16" | 12 | 5" | 12" | 12" | 8.8 | 312 | 4 | 4 | 4 | 238 | 38 | 4 | 76 |
| 1804 | 18' | 19' 5" | 9' 8 1/2" | 9' 2 1/2" | 4' 9 3/16" | 12 | 5" | 12" | 12" | 8.8 | 312 | 4 | 4 | 4 | 238 | 38 | 4 | 76 |
| 1805 | 18' | 19' 5" | 9' 8 1/2" | 9' 2 1/2" | 4' 9 3/16" | 12 | 5" | 12" | 12" | 8.8 | 312 | 4 | 4 | 4 | 238 | 38 | 4 | 76 |
| 1806 | 18' | 19' 5" | 9' 8 1/2" | 9' 2 1/2" | 4' 9 3/16" | 12 | 5" | 12" | 12" | 8.8 | 312 | 4 | 4 | 4 | 238 | 38 | 4 | 76 |
| 1807 | 18' | 19' 5" | 9' 8 1/2" | 9' 2 1/2" | 4' 9 3/16" | 12 | 5" | 12" | 18" | 11 | 312 | 3 | 4 | 4 | 238 | 38 | 4 | 76 |
| 1808 | 18' | 19' 5" | 9' 8 1/2" | 9' 2 1/2" | 4' 9 3/16" | 12 | 5" | 12" | 18" | 11 | 312 | 3 | 4 | 4 | 238 | 38 | 4 | 76 |
| 1809 | 18' | 19' 5" | 9' 8 1/2" | 9' 2 1/2" | 4' 9 3/16" | 12 | 5" | 12" | 18" | 11 | 312 | 3 | 4 | 5 | 240 | 38 | 4 | 76 |
| 1810 | 18' | 19' 5" | 9' 8 1/2" | 9' 2 1/2" | 4' 9 3/16" | 12 | 5.5" | 12" | 24" | 13 | 312 | 3 | 4 | 5 | 240 | 38 | 4 | 76 |
| 1811 | 18' | 19' 5" | 9' 8 1/2" | 9' 2 1/2" | 4' 9 3/16" | 12 | 5.5" | 12" | 24" | 13 | 312 | 3 | 6 | 4 | 356 | 38 | 4 | 76 |
| 1812 | 18' | 19' 7" | 9' 9 1/2" | 9' 2 1/2" | 4' 9 3/16" | 12 | 5.5" | 12" | 30" | 16.5 | 312 | 3 | 6 | 4 | 356 | 38 | 4 | 76 |
| 2103 | 21' | 22' 5" | 11' 2 1/2" | 10' 8 3/8" | 4' 9 1/8" | 14 | 5" | 12" | 12" | 11.5 | 418 | 5 | 4 | 4 | 280 | 44 | 4 | 88 |
| 2104 | 21' | 22' 5" | 11' 2 1/2" | 10' 8 3/8" | 4' 9 1/8" | 14 | 5" | 12" | 12" | 11.5 | 418 | 5 | 4 | 4 | 280 | 44 | 4 | 88 |
| 2105 | 21' | 22' 5" | 11' 2 1/2" | 10' 8 3/8" | 4' 9 1/8" | 14 | 5" | 12" | 12" | 11.5 | 418 | 5 | 4 | 4 | 280 | 44 | 4 | 88 |
| 2106 | 21' | 22' 5" | 11' 2 1/2" | 10' 8 3/8" | 4' 9 1/8" | 14 | 5" | 12" | 12" | 11.5 | 418 | 5 | 4 | 4 | 280 | 44 | 4 | 88 |
| 2107 | 21' | 22' 5" | 11' 2 1/2" | 10' 8 3/8" | 4' 9 1/8" | 14 | 5" | 12" | 18" | 13.5 | 418 | 5 | 4 | 4 | 280 | 44 | 4 | 88 |
| 2108 | 21' | 22' 5" | 11' 2 1/2" | 10' 8 3/8" | 4' 9 1/8" | 14 | 5" | 12" | 18" | 13.5 | 418 | 5 | 4 | 5 | 284 | 44 | 4 | 88 |
| 2109 | 21' | 22' 5" | 11' 2 1/2" | 10' 8 3/8" | 4' 9 1/8" | 14 | 5" | 12" | 18" | 13.5 | 418 | 5 | 4 | 5 | 284 | 44 | 4 | 88 |
| 2110 | 21' | 22' 5" | 11' 2 1/2" | 10' 8 3/8" | 4' 9 1/8" | 14 | 5.5" | 12" | 24" | 17 | 418 | 4 | 6 | 4 | 416 | 44 | 4 | 88 |
| 2111 | 21' | 22' 6" | 11' 3" | 10' 8 3/8" | 4' 9 1/8" | 14 | 5.5" | 12" | 30" | 19 | 418 | 4 | 6 | 4 | 416 | 44 | 4 | 88 |
| 2112 | 21' | 22' 8" | 11' 4" | 10' 8 3/8" | 4' 9 1/8" | 14 | 5.5" | 12" | 30" | 19 | 418 | 4 | 6 | 4 | 416 | 44 | 4 | 88 |
| 2403 | 24' | 25' 4" | 12' 8" | 12' 2 5/16" | 4' 9 1/16" | 16 | 5" | 12" | 12" | 14 | 540 | 7 | 4 | 4 | 314 | 50 | 4 | 100 |
| 2404 | 24' | 25' 4" | 12' 8" | 12' 2 5/16" | 4' 9 1/16" | 16 | 5" | 12" | 12" | 14 | 540 | 7 | 4 | 4 | 314 | 50 | 4 | 100 |
| 2405 | 24' | 25' 4" | 12' 8" | 12' 2 5/16" | 4' 9 1/16" | 16 | 5" | 12" | 12" | 14 | 540 | 7 | 4 | 4 | 314 | 50 | 4 | 100 |
| 2406 | 24' | 25' 4" | 12' 8" | 12' 2 5/16" | 4' 9 1/16" | 16 | 5" | 12" | 12" | 14 | 540 | 7 | 4 | 4 | 314 | 50 | 4 | 100 |
| 2407 | 24' | 25' 4" | 12' 8" | 12' 2 5/16" | 4' 9 1/16" | 16 | 5" | 12" | 18" | 17 | 540 | 6 | 4 | 5 | 318 | 50 | 4 | 100 |
| 2408 | 24' | 25' 4" | 12' 8" | 12' 2 5/16" | 4' 9 1/16" | 16 | 5" | 12" | 18" | 17 | 540 | 6 | 4 | 5 | 318 | 50 | 4 | 100 |
| 2409 | 24' | 25' 4" | 12' 8" | 12' 2 5/16" | 4' 9 1/16" | 16 | 5" | 12" | 24" | 20 | 540 | 6 | 4 | 5 | 318 | 50 | 4 | 100 |
| 2410 | 24' | 25' 4" | 12' 8" | 12' 2 5/16" | 4' 9 1/16" | 16 | 5.5" | 12" | 24" | 20 | 540 | 6 | 6 | 4 | 448 | 50 | 4 | 100 |
| 2411 | 24' | 25' 6" | 12' 9" | 12' 2 5/16" | 4' 9 1/16" | 16 | 5.5" | 12" | 30" | 23 | 540 | 6 | 6 | 4 | 448 | 50 | 4 | 100 |
| 2412 | 24' | 25' 8" | 12' 10" | 12' 2 5/16" | 4' 9 1/16" | 16 | 5.5" | 12" | 36" | 26 | 540 | 6 | 6 | 5 | 454 | 50 | 4 | 100 |
| 2703 | 27' | 28' 4" | 14' 2" | 13' 8 3/16" | 4' 9 1/16" | 18 | 5" | 12" | 12" | 17 | 677 | 8 | 4 | 4 | 358 | 57 | 4 | 114 |
| 2704 | 27' | 28' 4" | 14' 2" | 13' 8 3/16" | 4' 9 1/16" | 18 | 5" | 12" | 12" | 17 | 677 | 8 | 4 | 4 | 358 | 57 | 4 | 114 |
| 2705 | 27' | 28' 4" | 14' 2" | 13' 8 3/16" | 4' 9 1/16" | 18 | 5" | 12" | 12" | 17 | 677 | 8 | 4 | 4 | 358 | 57 | 4 | 114 |
| 2706 | 27' | 28' 4" | 14' 2" | 13' 8 3/16" | 4' 9 1/16" | 18 | 5" | 12" | 12" | 17 | 677 | 8 | 4 | 4 | 358 | 57 | 4 | 114 |
| 2707 | 27' | 28' 4" | 14' 2" | 13' 8 3/16" | 4' 9 1/16" | 18 | 5.5" | 12" | 18" | 20 | 677 | 8 | 4 | 5 | 364 | 57 | 4 | 114 |
| 2708 | 27' | 28' 4" | 14' 2" | 13' 8 3/16" | 4' 9 1/16" | 18 | 5.5" | 12" | 18" | 20 | 677 | 8 | 4 | 5 | 364 | 57 | 4 | 114 |
| 2709 | 27' | 28' 4" | 14' 2" | 13' 8 3/16" | 4' 9 1/16" | 18 | 5.5" | 12" | 24" | 23 | 677 | 8 | 4 | 5 | 364 | 57 | 4 | 114 |
| 2710 | 27' | 28' 4" | 14' 2" | 13' 8 3/16" | 4' 9 1/16" | 18 | 5.5" | 12" | 24" | 23 | 677 | 7 | 6 | 5 | 540 | 57 | 4 | 114 |
| 2711 | 27' | 28' 6" | 14' 3" | 13' 8 3/16" | 4' 9 1/16" | 18 | 5.5" | 12" | 30" | 27 | 677 | 7 | 6 | 5 | 540 | 57 | 4 | 114 |
| 2712 | 27' | 28' 8" | 14' 4" | 13' 8 3/16" | 4' 9 1/16" | 18 | 5.5" | 12" | 36" | 31 | 677 | 7 | 6 | 5 | 540 | 57 | 4 | 114 |
| 3003 | 30' | 31' 4" | 15' 8" | 15' 2 1/8" | 4' 9" | 20 | 5" | 12" | 12" | 21 | 830 | 10 | 4 | 4 | 394 | 63 | 4 | 126 |
| 3004 | 30' | 31' 4" | 15' 8" | 15' 2 1/8" | 4' 9" | 20 | 5" | 12" | 12" | 21 | 830 | 10 | 4 | 4 | 394 | 63 | 4 | 126 |
| 3005 | 30' | 31' 4" | 15' 8" | 15' 2 1/8" | 4' 9" | 20 | 5" | 12" | 12" | 21 | 830 | 10 | 4 | 4 | 394 | 63 | 4 | 126 |
| 3006 | 30' | 31' 4" | 15' 8" | 15' 2 1/8" | 4' 9" | 20 | 5" | 12" | 12" | 21 | 830 | 10 | 4 | 4 | 394 | 63 | 4 | 126 |
| 3007 | 30' | 31' 4" | 15' 8" | 15' 2 1/8" | 4' 9" | 20 | 5.5" | 12" | 18" | 24.5 | 830 | 10 | 4 | 5 | 400 | 63 | 4 | 126 |
| 3008 | 30' | 31' 4" | 15' 8" | 15' 2 1/8" | 4' 9" | 20 | 5.5" | 12" | 18" | 24.5 | 830 | 10 | 4 | 5 | 400 | 63 | 4 | 126 |
| 3009 | 30' | 31' 4" | 15' 8" | 15' 2 1/8" | 4' 9" | 20 | 5.5" | 12" | 24" | 28.5 | 830 | 10 | 4 | 5 | 400 | 63 | 4 | 126 |
| 3010 | 30' | 31' 4" | 15' 8" | 15' 2 1/8" | 4' 9" | 20 | 6" | 12" | 30" | 31.5 | 830 | 9 | 6 | 5 | 600 | 63 | 4 | 126 |
| 3011 | 30' | 31' 6" | 15' 9" | 15' 2 1/8" | 4' 9" | 20 | 6" | 12" | 30" | 31.5 | 830 | 9 | 6 | 5 | 600 | 63 | 4 | 126 |
| 3012 | 30' | 31' 8" | 15' 10" | 15' 2 1/8" | 4' 9" | 20 | 6" | 12" | 36" | 36 | 830 | 9 | 6 | 5 | 600 | 63 | 4 | 126 |
| 3303 | 33' | 34' 4" | 17' 2" | 16' 8" | 4' 8 15/16" | 22 | 5" | 12" | 12" | 24.5 | 998 | 13 | 4 | 5 | 444 | 69 | 4 | 138 |
| 3304 | 33' | 34' 4" | 17' 2" | 16' 8" | 4' 8 15/16" | 22 | 5" | 12" | 12" | 24.5 | 998 | 13 | 4 | 5 | 444 | 69 | 4 | 138 |
| 3305 | 33' | 34' 4" | 17' 2" | 16' 8" | 4' 8 15/16" | 22 | 5" | 12" | 12" | 24.5 | 998 | 13 | 4 | 5 | 444 | 69 | 4 | 138 |
| 3306 | 33' | 34' 4" | 17' 2" | 16' 8" | 4' 8 15/16" | 22 | 5" | 12" | 12" | 24.5 | 998 | 13 | 4 | 5 | 444 | 69 | 4 | 138 |
| 3307 | 33' | 34' 4" | 17' 2" | 16' 8" | 4' 8 15/16" | 22 | 5.5" | 12" | 18" | 28 | 998 | 12 | 4 | 6 | 450 | 69 | 4 | 138 |
| 3308 | 33' | 34' 4" | 17' 2" | 16' 8" | 4' 8 15/16" | 22 | 5.5" | 12" | 18" | 28 | 998 | 12 | 4 | 6 | 450 | 69 | 4 | 138 |
| 3309 | 33' | 34' 4" | 17' 2" | 16' 8" | 4' 8 15/16" | 22 | 5.5" | 12" | 24" | 32.5 | 998 | 12 | 4 | 6 | 450 | 69 | 4 | 138 |
| 3310 | 33' | 34' 4" | 17' 2" | 16' 8" | 4' 8 15/16" | 22 | 6" | 12" | 30" | 36 | 998 | 11 | 6 | 5 | 660 | 69 | 4 | 138 |
| 3311 | 33' | 34' 6" | 17' 3" | 16' 8" | 4' 8 15/16" | 22 | 6" | 12" | 30" | 36 | 998 | 11 | 6 | 5 | 660 | 69 | 4 | 138 |
| 3312 | 33' | 34' 8" | 17' 4" | 16' 8" | 4' 8 15/16" | 22 | 6" | 12" | 36" | 39.5 | 998 | 11 | 6 | 5 | 660 | 69 | 4 | 138 |

| Model | Nom. Bin Diam. | Concrete | | Anchor | | | | | 18" Above Grade | | | | | | | | | | |
|-------|----------------|-------------|-------------|--------------|-------------|-------|------|-----|-----------------|----------|-----------------|------------------|---------------|------|--------|-------------------|------|--------|--|
| | | Diameter | Radius | Radius | Chord | Total | T | D | W | Concrete | | | Footing Rebar | | | Vert Rebar (24"L) | | | |
| | | | | | | | | | | cu yds | Wire Mesh sq ft | Fill Sand cu yds | Qty | Size | Lin Ft | Qty | Size | Lin Ft | |
| 3603 | 36' | 37' 4" | 18' 8" | 18' 1 15/16" | 4' 8 7/8" | 24 | 5" | 12" | 12" | 28 | 1182 | 15 | 4 | 5 | 480 | 75 | 4 | 150 | |
| 3604 | 36' | 37' 4" | 18' 8" | 18' 1 15/16" | 4' 8 7/8" | 24 | 5" | 12" | 12" | 28 | 1182 | 15 | 4 | 5 | 480 | 75 | 4 | 150 | |
| 3605 | 36' | 37' 4" | 18' 8" | 18' 1 15/16" | 4' 8 7/8" | 24 | 5" | 12" | 12" | 28 | 1182 | 15 | 4 | 5 | 480 | 75 | 4 | 150 | |
| 3606 | 36' | 37' 4" | 18' 8" | 18' 1 15/16" | 4' 8 7/8" | 24 | 5" | 12" | 12" | 28 | 1182 | 15 | 4 | 5 | 480 | 75 | 4 | 150 | |
| 3607 | 36' | 37' 4" | 18' 8" | 18' 1 15/16" | 4' 8 7/8" | 24 | 5.5" | 12" | 18" | 32.5 | 1182 | 14 | 4 | 6 | 486 | 75 | 4 | 150 | |
| 3608 | 36' | 37' 4" | 18' 8" | 18' 1 15/16" | 4' 8 7/8" | 24 | 5.5" | 12" | 24" | 36.5 | 1182 | 14 | 4 | 6 | 486 | 75 | 4 | 150 | |
| 3609 | 36' | 37' 4" | 18' 8" | 18' 1 15/16" | 4' 8 7/8" | 24 | 5.5" | 12" | 24" | 36.5 | 1182 | 14 | 4 | 6 | 486 | 75 | 4 | 150 | |
| 3610 | 36' | 37' 4" | 18' 8" | 18' 1 15/16" | 4' 8 7/8" | 24 | 6" | 12" | 30" | 41.5 | 1182 | 13 | 6 | 5 | 710 | 75 | 4 | 150 | |
| 3611 | 36' | 37' 6" | 18' 9" | 18' 1 15/16" | 4' 8 7/8" | 24 | 6" | 12" | 36" | 45 | 1182 | 13 | 6 | 5 | 710 | 75 | 4 | 150 | |
| 3612 | 36' | 37' 8" | 18' 10" | 18' 1 15/16" | 4' 8 7/8" | 24 | 6" | 12" | 36" | 45 | 1182 | 13 | 6 | 6 | 716 | 75 | 4 | 150 | |
| 4203 | 42' | 43' 3" | 21' 7 1/2" | 21' 1 3/4" | 4' 8 13/16" | 28 | 5.5" | 12" | 12" | 36.5 | 1597 | 21 | 4 | 5 | 540 | 88 | 4 | 176 | |
| 4204 | 42' | 43' 3" | 21' 7 1/2" | 21' 1 3/4" | 4' 8 13/16" | 28 | 5.5" | 12" | 12" | 36.5 | 1597 | 21 | 4 | 5 | 540 | 88 | 4 | 176 | |
| 4205 | 42' | 43' 3" | 21' 7 1/2" | 21' 1 3/4" | 4' 8 13/16" | 28 | 5.5" | 12" | 12" | 36.5 | 1597 | 21 | 4 | 5 | 540 | 88 | 4 | 176 | |
| 4206 | 42' | 43' 3" | 21' 7 1/2" | 21' 1 3/4" | 4' 8 13/16" | 28 | 5.5" | 12" | 18" | 41.5 | 1597 | 20 | 4 | 6 | 566 | 88 | 4 | 176 | |
| 4207 | 42' | 43' 3" | 21' 7 1/2" | 21' 1 3/4" | 4' 8 13/16" | 28 | 5.5" | 12" | 18" | 41.5 | 1597 | 20 | 4 | 6 | 566 | 88 | 4 | 176 | |
| 4208 | 42' | 43' 3" | 21' 7 1/2" | 21' 1 3/4" | 4' 8 13/16" | 28 | 6" | 12" | 24" | 46.5 | 1597 | 19 | 6 | 5 | 830 | 88 | 4 | 176 | |
| 4209 | 42' | 43' 3" | 21' 7 1/2" | 21' 1 3/4" | 4' 8 13/16" | 28 | 6" | 12" | 24" | 46.5 | 1597 | 19 | 6 | 5 | 830 | 88 | 4 | 176 | |
| 4210 | 42' | 44' 3" | 22' 1 7/16" | 21' 1 3/4" | 4' 8 13/16" | 28 | 6" | 12" | 30" | 51 | 1597 | 19 | 6 | 5 | 830 | 88 | 4 | 176 | |
| 4211 | 42' | 44' 3" | 22' 1 7/16" | 21' 1 3/4" | 4' 8 13/16" | 28 | 6" | 12" | 36" | 57 | 1597 | 19 | 6 | 6 | 836 | 88 | 4 | 176 | |
| 4212 | 42' | 44' 3" | 22' 1 7/16" | 21' 1 3/4" | 4' 8 13/16" | 28 | 6" | 18" | 42" | 70.5 | 1597 | 18 | 6 | 6 | 836 | 88 | 4 | 176 | |
| 4803 | 48' | 49' 3" | 24' 7 1/2" | 24' 1 1/2" | 4' 8 3/4" | 32 | 6" | 12" | 12" | 46 | 2074 | 27 | 4 | 5 | 640 | 100 | 4 | 200 | |
| 4804 | 48' | 49' 3" | 24' 7 1/2" | 24' 1 1/2" | 4' 8 3/4" | 32 | 6" | 12" | 12" | 46 | 2074 | 27 | 4 | 5 | 640 | 100 | 4 | 200 | |
| 4805 | 48' | 49' 3" | 24' 7 1/2" | 24' 1 1/2" | 4' 8 3/4" | 32 | 6" | 12" | 12" | 46 | 2074 | 27 | 4 | 5 | 640 | 100 | 4 | 200 | |
| 4806 | 48' | 49' 3" | 24' 7 1/2" | 24' 1 1/2" | 4' 8 3/4" | 32 | 6" | 12" | 18" | 51.5 | 2074 | 26 | 4 | 6 | 648 | 100 | 4 | 200 | |
| 4807 | 48' | 49' 3" | 24' 7 1/2" | 24' 1 1/2" | 4' 8 3/4" | 32 | 6" | 12" | 18" | 51.5 | 2074 | 26 | 4 | 6 | 648 | 100 | 4 | 200 | |
| 4808 | 48' | 49' 3" | 24' 7 1/2" | 24' 1 1/2" | 4' 8 3/4" | 32 | 6" | 12" | 24" | 57.5 | 2074 | 25 | 6 | 5 | 960 | 100 | 4 | 200 | |
| 4809 | 48' | 49' 3" | 24' 7 1/2" | 24' 1 1/2" | 4' 8 3/4" | 32 | 6" | 12" | 30" | 63.5 | 2074 | 25 | 6 | 5 | 960 | 100 | 4 | 200 | |
| 4810 | 48' | 50' 2 7/16" | 25' 1 7/32" | 24' 1 1/2" | 4' 8 3/4" | 32 | 6" | 12" | 30" | 63.5 | 2074 | 25 | 6 | 5 | 960 | 100 | 4 | 200 | |
| 4811 | 48' | 50' 2 7/16" | 25' 1 7/32" | 24' 1 1/2" | 4' 8 3/4" | 32 | 6" | 12" | 36" | 69 | 2074 | 24 | 6 | 6 | 972 | 100 | 4 | 200 | |
| 4812 | 48' | 50' 2 7/16" | 25' 1 7/32" | 24' 1 1/2" | 4' 8 3/4" | 32 | 6" | 18" | 42" | 85.5 | 2074 | 24 | 6 | 6 | 972 | 100 | 4 | 200 | |

| Model | Nom. Bin Diam. | Concrete | | Anchor | | | | | 24" Above Grade | | | | | | | | | | |
|-------|----------------|------------|------------|-------------|------------|-------|------|-----|-----------------|----------|-----------------|------------------|---------------|------|--------|-------------------|------|--------|--|
| | | Diameter | Radius | Radius | Chord | Total | T | D | W | Concrete | | | Footing Rebar | | | Vert Rebar (30"L) | | | |
| | | | | | | | | | | cu yds | Wire Mesh sq ft | Fill Sand cu yds | Qty | Size | Lin Ft | Qty | Size | Lin Ft | |
| 1503 | 15' | 16' 5 1/8" | 8' 2 9/16" | 7' 8 19/32" | 4' 9 7/32" | 10 | 5" | 12" | 12" | 8 | 221 | 3 | 4 | 4 | 200 | 32 | 4 | 80 | |
| 1504 | 15' | 16' 5 1/8" | 8' 2 9/16" | 7' 8 19/32" | 4' 9 7/32" | 10 | 5" | 12" | 12" | 8 | 221 | 3 | 4 | 4 | 200 | 32 | 4 | 80 | |
| 1505 | 15' | 16' 5 1/8" | 8' 2 9/16" | 7' 8 19/32" | 4' 9 7/32" | 10 | 5" | 12" | 12" | 8 | 221 | 3 | 4 | 4 | 200 | 32 | 4 | 80 | |
| 1506 | 15' | 16' 5 1/8" | 8' 2 9/16" | 7' 8 19/32" | 4' 9 7/32" | 10 | 5" | 12" | 12" | 8 | 221 | 3 | 4 | 4 | 200 | 32 | 4 | 80 | |
| 1507 | 15' | 16' 5 1/8" | 8' 2 9/16" | 7' 8 19/32" | 4' 9 7/32" | 10 | 5" | 12" | 12" | 8 | 221 | 3 | 4 | 4 | 200 | 32 | 4 | 80 | |
| 1508 | 15' | 16' 5 1/8" | 8' 2 9/16" | 7' 8 19/32" | 4' 9 7/32" | 10 | 5" | 12" | 18" | 10 | 221 | 3 | 4 | 4 | 200 | 32 | 4 | 80 | |
| 1509 | 15' | 16' 5 1/8" | 8' 2 9/16" | 7' 8 19/32" | 4' 9 7/32" | 10 | 5" | 12" | 18" | 10 | 221 | 3 | 4 | 5 | 204 | 32 | 4 | 80 | |
| 1510 | 15' | 16' 5 1/8" | 8' 2 9/16" | 7' 8 19/32" | 4' 9 7/32" | 10 | 5.5" | 12" | 24" | 12 | 221 | 2 | 4 | 5 | 204 | 32 | 4 | 80 | |
| 1511 | 15' | 16' 5 1/8" | 8' 2 9/16" | 7' 8 19/32" | 4' 9 7/32" | 10 | 5.5" | 12" | 24" | 12 | 221 | 2 | 6 | 4 | 300 | 32 | 4 | 80 | |
| 1512 | 15' | 16' 7 1/8" | 8' 3 9/16" | 7' 8 19/32" | 4' 9 7/32" | 10 | 5.5" | 12" | 30" | 14 | 221 | 2 | 6 | 4 | 300 | 32 | 4 | 80 | |
| 1803 | 18' | 19' 5" | 9' 8 1/2" | 9' 2 1/2" | 4' 9 3/16" | 12 | 5" | 12" | 12" | 10 | 312 | 4 | 4 | 4 | 238 | 38 | 4 | 95 | |
| 1804 | 18' | 19' 5" | 9' 8 1/2" | 9' 2 1/2" | 4' 9 3/16" | 12 | 5" | 12" | 12" | 10 | 312 | 4 | 4 | 4 | 238 | 38 | 4 | 95 | |
| 1805 | 18' | 19' 5" | 9' 8 1/2" | 9' 2 1/2" | 4' 9 3/16" | 12 | 5" | 12" | 12" | 10 | 312 | 4 | 4 | 4 | 238 | 38 | 4 | 95 | |
| 1806 | 18' | 19' 5" | 9' 8 1/2" | 9' 2 1/2" | 4' 9 3/16" | 12 | 5" | 12" | 12" | 10 | 312 | 4 | 4 | 4 | 238 | 38 | 4 | 95 | |
| 1807 | 18' | 19' 5" | 9' 8 1/2" | 9' 2 1/2" | 4' 9 3/16" | 12 | 5" | 12" | 18" | 13 | 312 | 3 | 4 | 4 | 238 | 38 | 4 | 95 | |
| 1808 | 18' | 19' 5" | 9' 8 1/2" | 9' 2 1/2" | 4' 9 3/16" | 12 | 5" | 12" | 18" | 13 | 312 | 3 | 4 | 4 | 238 | 38 | 4 | 95 | |
| 1809 | 18' | 19' 5" | 9' 8 1/2" | 9' 2 1/2" | 4' 9 3/16" | 12 | 5" | 12" | 18" | 13 | 312 | 3 | 4 | 5 | 240 | 38 | 4 | 95 | |
| 1810 | 18' | 19' 5" | 9' 8 1/2" | 9' 2 1/2" | 4' 9 3/16" | 12 | 5.5" | 12" | 24" | 15.5 | 312 | 3 | 4 | 5 | 240 | 38 | 4 | 95 | |
| 1811 | 18' | 19' 5" | 9' 8 1/2" | 9' 2 1/2" | 4' 9 3/16" | 12 | 5.5" | 12" | 24" | 15.5 | 312 | 3 | 6 | 4 | 356 | 38 | 4 | 95 | |
| 1812 | 18' | 19' 7" | 9' 9 1/2" | 9' 2 1/2" | 4' 9 3/16" | 12 | 5.5" | 12" | 30" | 18.5 | 312 | 3 | 6 | 4 | 356 | 38 | 4 | 95 | |
| 2103 | 21' | 22' 5" | 11' 2 1/2" | 10' 8 3/8" | 4' 9 1/8" | 14 | 5" | 12" | 12" | 13 | 418 | 5 | 4 | 4 | 280 | 44 | 4 | 110 | |
| 2104 | 21' | 22' 5" | 11' 2 1/2" | 10' 8 3/8" | 4' 9 1/8" | 14 | 5" | 12" | 12" | 13 | 418 | 5 | 4 | 4 | 280 | 44 | 4 | 110 | |
| 2105 | 21' | 22' 5" | 11' 2 1/2" | 10' 8 3/8" | 4' 9 1/8" | 14 | 5" | 12" | 12" | 13 | 418 | 5 | 4 | 4 | 280 | 44 | 4 | 110 | |
| 2106 | 21' | 22' 5" | 11' 2 1/2" | 10' 8 3/8" | 4' 9 1/8" | 14 | 5" | 12" | 12" | 13 | 418 | 5 | 4 | 4 | 280 | 44 | 4 | 110 | |
| 2107 | 21' | 22' 5" | 11' 2 1/2" | 10' 8 3/8" | 4' 9 1/8" | 14 | 5" | 12" | 18" | 16 | 418 | 5 | 4 | 4 | 280 | 44 | 4 | 110 | |
| 2108 | 21' | 22' 5" | 11' 2 1/2" | 10' 8 3/8" | 4' 9 1/8" | 14 | 5" | 12" | 18" | 16 | 418 | 5 | 4 | 5 | 284 | 44 | 4 | 110 | |
| 2109 | 21' | 22' 5" | 11' 2 1/2" | 10' 8 3/8" | 4' 9 1/8" | 14 | 5" | 12" | 18" | 16 | 418 | 5 | 4 | 5 | 284 | 44 | 4 | 110 | |
| 2110 | 21' | 22' 5" | 11' 2 1/2" | 10' 8 3/8" | 4' 9 1/8" | 14 | 5.5" | 12" | 24" | 19 | 418 | 4 | 6 | 4 | 416 | 44 | 4 | 110 | |
| 2111 | 21' | 22' 6" | 11' 3" | 10' 8 3/8" | 4' 9 1/8" | 14 | 5.5" | 12" | 30" | 22 | 418 | 4 | 6 | 4 | 416 | 44 | 4 | 110 | |
| 2112 | 21' | 22' 8" | 11' 4" | 10' 8 3/8" | 4' 9 1/8" | 14 | 5.5" | 12" | 30" | 22 | 418 | 4 | 6 | 4 | 416 | 44 | 4 | 110 | |

| Model | Nom. Bin Diam. | Concrete | | Anchor | | | | 24" Above Grade | | | | | | | | | | |
|-------|----------------|-------------|-------------|--------------|-------------|-------|------|-----------------|-----|----------|-----------------|------------------|---------------|------|--------|-------------------|------|--------|
| | | Diameter | Radius | Radius | Chord | Total | T | D | W | Concrete | | | Footing Rebar | | | Vert Rebar (30"L) | | |
| | | | | | | | | | | cu yds | Wire Mesh sq ft | Fill Sand cu yds | Qty | Size | Lin Ft | Qty | Size | Lin Ft |
| 2403 | 24' | 25' 4" | 12' 8" | 12' 2 5/16" | 4' 9 1/16" | 16 | 5" | 12" | 12" | 15.5 | 540 | 7 | 4 | 4 | 314 | 50 | 4 | 125 |
| 2404 | 24' | 25' 4" | 12' 8" | 12' 2 5/16" | 4' 9 1/16" | 16 | 5" | 12" | 12" | 15.5 | 540 | 7 | 4 | 4 | 314 | 50 | 4 | 125 |
| 2405 | 24' | 25' 4" | 12' 8" | 12' 2 5/16" | 4' 9 1/16" | 16 | 5" | 12" | 12" | 15.5 | 540 | 7 | 4 | 4 | 314 | 50 | 4 | 125 |
| 2406 | 24' | 25' 4" | 12' 8" | 12' 2 5/16" | 4' 9 1/16" | 16 | 5" | 12" | 12" | 15.5 | 540 | 7 | 4 | 4 | 314 | 50 | 4 | 125 |
| 2407 | 24' | 25' 4" | 12' 8" | 12' 2 5/16" | 4' 9 1/16" | 16 | 5" | 12" | 18" | 19.5 | 540 | 6 | 4 | 5 | 318 | 50 | 4 | 125 |
| 2408 | 24' | 25' 4" | 12' 8" | 12' 2 5/16" | 4' 9 1/16" | 16 | 5" | 12" | 18" | 19.5 | 540 | 6 | 4 | 5 | 318 | 50 | 4 | 125 |
| 2409 | 24' | 25' 4" | 12' 8" | 12' 2 5/16" | 4' 9 1/16" | 16 | 5" | 12" | 24" | 22.5 | 540 | 6 | 4 | 5 | 318 | 50 | 4 | 125 |
| 2410 | 24' | 25' 4" | 12' 8" | 12' 2 5/16" | 4' 9 1/16" | 16 | 5.5" | 12" | 24" | 22.5 | 540 | 6 | 6 | 4 | 448 | 50 | 4 | 125 |
| 2411 | 24' | 25' 6" | 12' 9" | 12' 2 5/16" | 4' 9 1/16" | 16 | 5.5" | 12" | 30" | 26 | 540 | 6 | 6 | 4 | 448 | 50 | 4 | 125 |
| 2412 | 24' | 25' 8" | 12' 10" | 12' 2 5/16" | 4' 9 1/16" | 16 | 5.5" | 12" | 36" | 29.5 | 540 | 6 | 6 | 5 | 454 | 50 | 4 | 125 |
| 2703 | 27' | 28' 4" | 14' 2" | 13' 8 3/16" | 4' 9 1/16" | 18 | 5" | 12" | 12" | 18.5 | 677 | 8 | 4 | 4 | 358 | 57 | 4 | 142.5 |
| 2704 | 27' | 28' 4" | 14' 2" | 13' 8 3/16" | 4' 9 1/16" | 18 | 5" | 12" | 12" | 18.5 | 677 | 8 | 4 | 4 | 358 | 57 | 4 | 142.5 |
| 2705 | 27' | 28' 4" | 14' 2" | 13' 8 3/16" | 4' 9 1/16" | 18 | 5" | 12" | 12" | 18.5 | 677 | 8 | 4 | 4 | 358 | 57 | 4 | 142.5 |
| 2706 | 27' | 28' 4" | 14' 2" | 13' 8 3/16" | 4' 9 1/16" | 18 | 5" | 12" | 12" | 18.5 | 677 | 8 | 4 | 4 | 358 | 57 | 4 | 142.5 |
| 2707 | 27' | 28' 4" | 14' 2" | 13' 8 3/16" | 4' 9 1/16" | 18 | 5.5" | 12" | 18" | 22.5 | 677 | 8 | 4 | 5 | 364 | 57 | 4 | 142.5 |
| 2708 | 27' | 28' 4" | 14' 2" | 13' 8 3/16" | 4' 9 1/16" | 18 | 5.5" | 12" | 18" | 22.5 | 677 | 8 | 4 | 5 | 364 | 57 | 4 | 142.5 |
| 2709 | 27' | 28' 4" | 14' 2" | 13' 8 3/16" | 4' 9 1/16" | 18 | 5.5" | 12" | 24" | 26.5 | 677 | 8 | 4 | 5 | 364 | 57 | 4 | 142.5 |
| 2710 | 27' | 28' 4" | 14' 2" | 13' 8 3/16" | 4' 9 1/16" | 18 | 5.5" | 12" | 24" | 26.5 | 677 | 7 | 6 | 5 | 540 | 57 | 4 | 142.5 |
| 2711 | 27' | 28' 6" | 14' 3" | 13' 8 3/16" | 4' 9 1/16" | 18 | 5.5" | 12" | 30" | 31 | 677 | 7 | 6 | 5 | 540 | 57 | 4 | 142.5 |
| 2712 | 27' | 28' 8" | 14' 4" | 13' 8 3/16" | 4' 9 1/16" | 18 | 5.5" | 12" | 36" | 35 | 677 | 7 | 6 | 5 | 540 | 57 | 4 | 142.5 |
| 3003 | 30' | 31' 4" | 15' 8" | 15' 2 1/8" | 4' 9" | 20 | 5" | 12" | 12" | 23 | 830 | 10 | 4 | 4 | 394 | 63 | 4 | 157.5 |
| 3004 | 30' | 31' 4" | 15' 8" | 15' 2 1/8" | 4' 9" | 20 | 5" | 12" | 12" | 23 | 830 | 10 | 4 | 4 | 394 | 63 | 4 | 157.5 |
| 3005 | 30' | 31' 4" | 15' 8" | 15' 2 1/8" | 4' 9" | 20 | 5" | 12" | 12" | 23 | 830 | 10 | 4 | 4 | 394 | 63 | 4 | 157.5 |
| 3006 | 30' | 31' 4" | 15' 8" | 15' 2 1/8" | 4' 9" | 20 | 5" | 12" | 12" | 23 | 830 | 10 | 4 | 4 | 394 | 63 | 4 | 157.5 |
| 3007 | 30' | 31' 4" | 15' 8" | 15' 2 1/8" | 4' 9" | 20 | 5.5" | 12" | 18" | 27.5 | 830 | 10 | 4 | 5 | 400 | 63 | 4 | 157.5 |
| 3008 | 30' | 31' 4" | 15' 8" | 15' 2 1/8" | 4' 9" | 20 | 5.5" | 12" | 18" | 27.5 | 830 | 10 | 4 | 5 | 400 | 63 | 4 | 157.5 |
| 3009 | 30' | 31' 4" | 15' 8" | 15' 2 1/8" | 4' 9" | 20 | 5.5" | 12" | 24" | 31.5 | 830 | 10 | 4 | 5 | 400 | 63 | 4 | 157.5 |
| 3010 | 30' | 31' 4" | 15' 8" | 15' 2 1/8" | 4' 9" | 20 | 6" | 12" | 30" | 36 | 830 | 9 | 6 | 5 | 600 | 63 | 4 | 157.5 |
| 3011 | 30' | 31' 6" | 15' 9" | 15' 2 1/8" | 4' 9" | 20 | 6" | 12" | 30" | 36 | 830 | 9 | 6 | 5 | 600 | 63 | 4 | 157.5 |
| 3012 | 30' | 31' 8" | 15' 10" | 15' 2 1/8" | 4' 9" | 20 | 6" | 12" | 36" | 40 | 830 | 9 | 6 | 5 | 600 | 63 | 4 | 157.5 |
| 3303 | 33' | 34' 4" | 17' 2" | 16' 8" | 4' 8 15/16" | 22 | 5" | 12" | 12" | 26.5 | 998 | 13 | 4 | 5 | 444 | 69 | 4 | 172.5 |
| 3304 | 33' | 34' 4" | 17' 2" | 16' 8" | 4' 8 15/16" | 22 | 5" | 12" | 12" | 26.5 | 998 | 13 | 4 | 5 | 444 | 69 | 4 | 172.5 |
| 3305 | 33' | 34' 4" | 17' 2" | 16' 8" | 4' 8 15/16" | 22 | 5" | 12" | 12" | 26.5 | 998 | 13 | 4 | 5 | 444 | 69 | 4 | 172.5 |
| 3306 | 33' | 34' 4" | 17' 2" | 16' 8" | 4' 8 15/16" | 22 | 5" | 12" | 12" | 26.5 | 998 | 13 | 4 | 5 | 444 | 69 | 4 | 172.5 |
| 3307 | 33' | 34' 4" | 17' 2" | 16' 8" | 4' 8 15/16" | 22 | 5.5" | 12" | 18" | 31.5 | 998 | 12 | 4 | 6 | 450 | 69 | 4 | 172.5 |
| 3308 | 33' | 34' 4" | 17' 2" | 16' 8" | 4' 8 15/16" | 22 | 5.5" | 12" | 24" | 36 | 998 | 12 | 4 | 6 | 450 | 69 | 4 | 172.5 |
| 3309 | 33' | 34' 4" | 17' 2" | 16' 8" | 4' 8 15/16" | 22 | 5.5" | 12" | 24" | 36 | 998 | 12 | 4 | 6 | 450 | 69 | 4 | 172.5 |
| 3310 | 33' | 34' 4" | 17' 2" | 16' 8" | 4' 8 15/16" | 22 | 6" | 12" | 30" | 41 | 998 | 11 | 6 | 5 | 660 | 69 | 4 | 172.5 |
| 3311 | 33' | 34' 6" | 17' 3" | 16' 8" | 4' 8 15/16" | 22 | 6" | 12" | 36" | 46 | 998 | 11 | 6 | 5 | 660 | 69 | 4 | 172.5 |
| 3312 | 33' | 34' 8" | 17' 4" | 16' 8" | 4' 8 15/16" | 22 | 6" | 12" | 36" | 46 | 998 | 11 | 6 | 5 | 660 | 69 | 4 | 172.5 |
| 3603 | 36' | 37' 4" | 18' 8" | 18' 1 15/16" | 4' 8 7/8" | 24 | 5" | 12" | 12" | 30 | 1182 | 15 | 4 | 5 | 480 | 75 | 4 | 187.5 |
| 3604 | 36' | 37' 4" | 18' 8" | 18' 1 15/16" | 4' 8 7/8" | 24 | 5" | 12" | 12" | 30 | 1182 | 15 | 4 | 5 | 480 | 75 | 4 | 187.5 |
| 3605 | 36' | 37' 4" | 18' 8" | 18' 1 15/16" | 4' 8 7/8" | 24 | 5" | 12" | 12" | 30 | 1182 | 15 | 4 | 5 | 480 | 75 | 4 | 187.5 |
| 3606 | 36' | 37' 4" | 18' 8" | 18' 1 15/16" | 4' 8 7/8" | 24 | 5" | 12" | 18" | 35.5 | 1182 | 15 | 4 | 5 | 480 | 75 | 4 | 187.5 |
| 3607 | 36' | 37' 4" | 18' 8" | 18' 1 15/16" | 4' 8 7/8" | 24 | 5.5" | 12" | 18" | 35.5 | 1182 | 14 | 4 | 6 | 486 | 75 | 4 | 187.5 |
| 3608 | 36' | 37' 4" | 18' 8" | 18' 1 15/16" | 4' 8 7/8" | 24 | 5.5" | 12" | 24" | 41.5 | 1182 | 14 | 4 | 6 | 486 | 75 | 4 | 187.5 |
| 3609 | 36' | 37' 4" | 18' 8" | 18' 1 15/16" | 4' 8 7/8" | 24 | 5.5" | 12" | 24" | 41.5 | 1182 | 14 | 4 | 6 | 486 | 75 | 4 | 187.5 |
| 3610 | 36' | 37' 4" | 18' 8" | 18' 1 15/16" | 4' 8 7/8" | 24 | 6" | 12" | 30" | 46.5 | 1182 | 13 | 6 | 5 | 710 | 75 | 4 | 187.5 |
| 3611 | 36' | 37' 6" | 18' 9" | 18' 1 15/16" | 4' 8 7/8" | 24 | 6" | 12" | 36" | 52.5 | 1182 | 13 | 6 | 5 | 710 | 75 | 4 | 187.5 |
| 3612 | 36' | 37' 8" | 18' 10" | 18' 1 15/16" | 4' 8 7/8" | 24 | 6" | 12" | 42" | 62 | 1182 | 13 | 6 | 6 | 716 | 75 | 4 | 187.5 |
| 4203 | 42' | 43' 3" | 21' 7 1/2" | 21' 1 3/4" | 4' 8 13/16" | 28 | 5.5" | 12" | 12" | 39.5 | 1597 | 21 | 4 | 5 | 540 | 88 | 4 | 220 |
| 4204 | 42' | 43' 3" | 21' 7 1/2" | 21' 1 3/4" | 4' 8 13/16" | 28 | 5.5" | 12" | 12" | 39.5 | 1597 | 21 | 4 | 5 | 540 | 88 | 4 | 220 |
| 4205 | 42' | 43' 3" | 21' 7 1/2" | 21' 1 3/4" | 4' 8 13/16" | 28 | 5.5" | 12" | 12" | 39.5 | 1597 | 21 | 4 | 5 | 540 | 88 | 4 | 220 |
| 4206 | 42' | 43' 3" | 21' 7 1/2" | 21' 1 3/4" | 4' 8 13/16" | 28 | 5.5" | 12" | 18" | 45.5 | 1597 | 20 | 4 | 6 | 566 | 88 | 4 | 220 |
| 4207 | 42' | 43' 3" | 21' 7 1/2" | 21' 1 3/4" | 4' 8 13/16" | 28 | 5.5" | 12" | 18" | 45.5 | 1597 | 20 | 4 | 6 | 566 | 88 | 4 | 220 |
| 4208 | 42' | 43' 3" | 21' 7 1/2" | 21' 1 3/4" | 4' 8 13/16" | 28 | 6" | 12" | 24" | 51.5 | 1597 | 19 | 6 | 5 | 830 | 88 | 4 | 220 |
| 4209 | 42' | 43' 3" | 21' 7 1/2" | 21' 1 3/4" | 4' 8 13/16" | 28 | 6" | 12" | 30" | 58.5 | 1597 | 19 | 6 | 5 | 830 | 88 | 4 | 220 |
| 4210 | 42' | 44' 3" | 22' 1 7/16" | 21' 1 3/4" | 4' 8 13/16" | 28 | 6" | 12" | 30" | 58.5 | 1597 | 19 | 6 | 5 | 830 | 88 | 4 | 220 |
| 4211 | 42' | 44' 3" | 22' 1 7/16" | 21' 1 3/4" | 4' 8 13/16" | 28 | 6" | 12" | 36" | 64.5 | 1597 | 19 | 6 | 6 | 836 | 88 | 4 | 220 |
| 4212 | 42' | 44' 3" | 22' 1 7/16" | 21' 1 3/4" | 4' 8 13/16" | 28 | 6" | 18" | 42" | 78 | 1597 | 18 | 6 | 6 | 836 | 88 | 4 | 220 |
| 4803 | 48' | 49' 3" | 24' 7 1/2" | 24' 1 1/2" | 4' 8 3/4" | 32 | 6" | 12" | 12" | 48.5 | 2074 | 27 | 4 | 5 | 640 | 100 | 4 | 250 |
| 4804 | 48' | 49' 3" | 24' 7 1/2" | 24' 1 1/2" | 4' 8 3/4" | 32 | 6" | 12" | 12" | 48.5 | 2074 | 27 | 4 | 5 | 640 | 100 | 4 | 250 |
| 4805 | 48' | 49' 3" | 24' 7 1/2" | 24' 1 1/2" | 4' 8 3/4" | 32 | 6" | 12" | 18" | 56 | 2074 | 27 | 4 | 5 | 640 | 100 | 4 | 250 |
| 4806 | 48' | 49' 3" | 24' 7 1/2" | 24' 1 1/2" | 4' 8 3/4" | 32 | 6" | 12" | 18" | 56 | 2074 | 26 | 4 | 6 | 648 | 100 | 4 | 250 |
| 4807 | 48' | 49' 3" | 24' 7 1/2" | 24' 1 1/2" | 4' 8 3/4" | 32 | 6" | 12" | 24" | 63 | 2074 | 26 | 4 | 6 | 648 | 100 | 4 | 250 |
| 4808 | 48' | 49' 3" | 24' 7 1/2" | 24' 1 1/2" | 4' 8 3/4" | 32 | 6" | 12" | 24" | 63 | 2074 | 25 | 6 | 5 | 960 | 100 | 4 | 250 |
| 4809 | 48' | 49' 3" | 24' 7 1/2" | 24' 1 1/2" | 4' 8 3/4" | 32 | 6" | 12" | 30" | 70.8 | 2074 | 25 | 6 | 5 | 960 | 100 | 4 | 250 |
| 4810 | 48' | 50' 2 7/16" | 25' 1 7/32" | 24' 1 1/2" | 4' 8 3/4" | 32 | 6" | 12" | 36" | 78 | 2074 | 25 | 6 | 5 | 960 | 100 | 4 | 250 |
| 4811 | 48' | 50' 2 7/16" | 25' 1 7/32" | 24' 1 1/2" | 4' 8 3/4" | 32 | 6" | 12" | 42" | 84.5 | 2074 | 24 | 6 | 6 | 972 | 100 | 4 | 250 |
| 4812 | 48' | 50' 2 7/16" | 25' 1 7/32" | 24' 1 1/2" | 4' 8 3/4" | 32 | 6" | 18" | 48" | 103 | 2074 | 24 | 6 | 6 | 972 | 100 | 4 | 250 |

Placing Anchor Bolts

STEP 1: Find anchor radius based on diameter of bin being built (Anchor radius is noted to left of Anchor Placement drawing).

STEP 2: Scribe anchor radius into concrete.

STEP 3: Determine where origin point will be. Have one person hold tape measure there. Have other person hold tape measure at distances shown at left of Anchor Placement drawing. Mark spots on radius – A, B, C, etc. – for anchor points. **NOTE:** Not all anchor points will be used for anchors. Repeat this step on other side until all anchor points are marked on radius.

STEP 4: Working counterclockwise from origin point, place an anchor at every other marked point, as shown on left side of drawing (B, D, etc.).

15' DIAMETER
ANCHOR PLACEMENT

| POINT | DISTANCE |
|-------|--------------|
| A | 4' 9 7/32" |
| B | 9' 27/32" |
| C | 12' 5 13/16" |
| D | 14' 8 1/8" |
| E | 15' 5 3/16" |

CONCRETE RADIUS: See Chart
ANCHOR RADIUS: 7' 8 19/32"
BIN RADIUS: 7' 5 1/2"

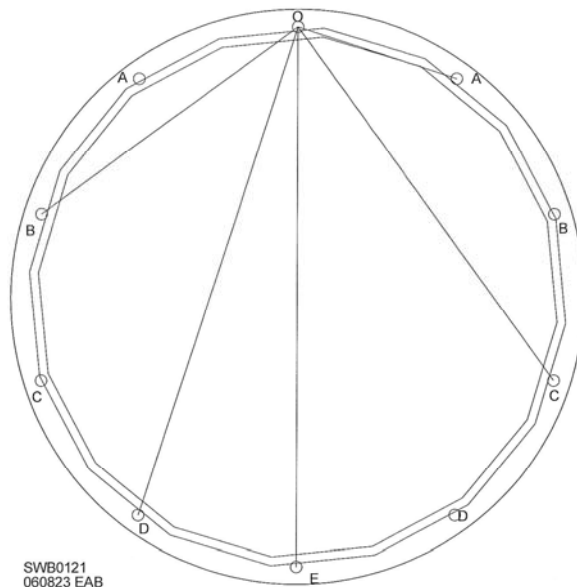

SWB0121
060823 EAB

18' DIAMETER
ANCHOR PLACEMENT

| POINT | DISTANCE |
|-------|-------------|
| A | 4' 9 3/16" |
| B | 9' 2 1/2" |
| C | 13' 1/4" |
| D | 15' 11 3/8" |
| E | 17' 9 1/2" |
| F | 18' 5" |

CONCRETE RADIUS: See Chart
ANCHOR RADIUS: 9' 2 1/2"
BIN RADIUS: 8' 11 7/16"

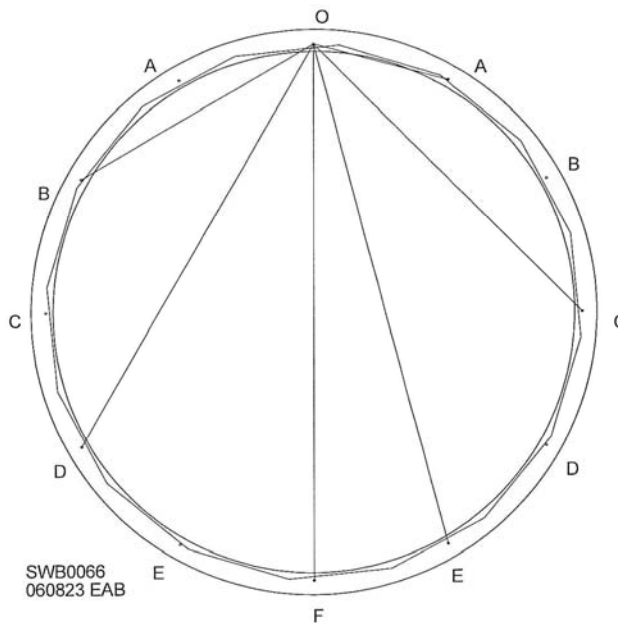

SWB0066
060823 EAB

21' DIAMETER ANCHOR PLACEMENT

| POINT | DISTANCE |
|-------|--------------|
| A | 4' 9 1/8" |
| B | 9' 3 3/8" |
| C | 13' 4 1/16" |
| D | 16' 8 3/4" |
| E | 19' 3 5/16" |
| F | 20' 10 5/16" |
| G | 21' 4 3/4" |

CONCRETE RADIUS: See Chart
 ANCHOR RADIUS: 10' 8 3/8"
 BIN RADIUS: 10' 5 5/16"

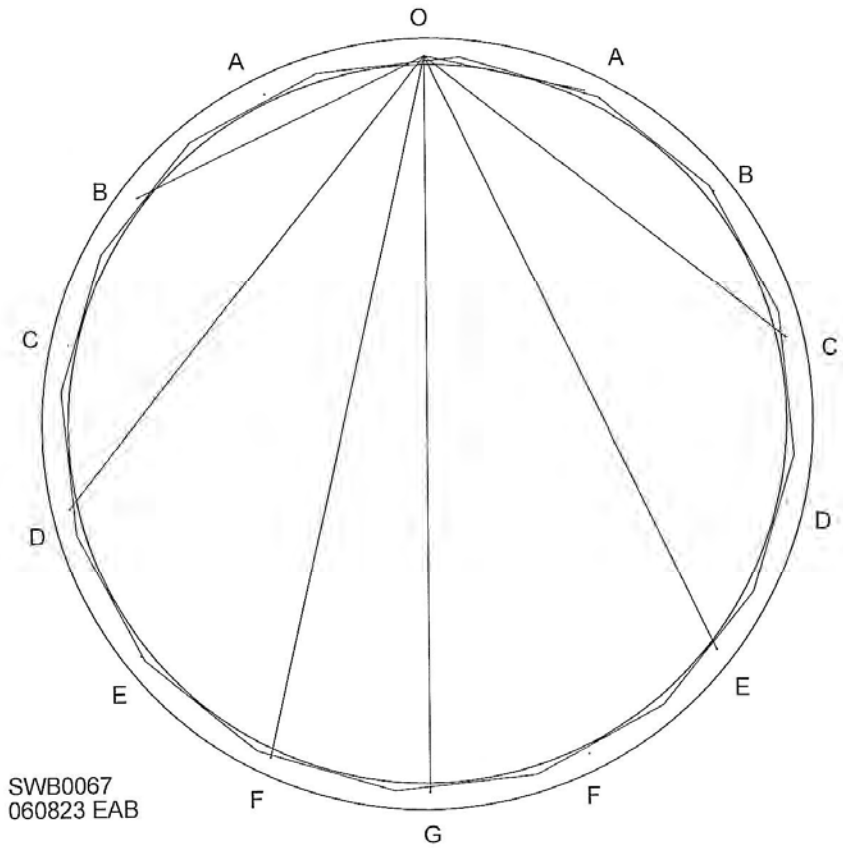

24' DIAMETER ANCHOR PLACEMENT

| POINT | DISTANCE |
|-------|--------------|
| A | 4' 9 1/16" |
| B | 9' 4" |
| C | 13' 6 9/16" |
| D | 17' 2 15/16" |
| E | 20' 3 5/16" |
| F | 22' 6 3/8" |
| G | 23' 11" |
| H | 24' 4 5/8" |

CONCRETE RADIUS: See Chart
 ANCHOR RADIUS: 12' 2 5/16"
 BIN RADIUS: 11' 11 1/4"

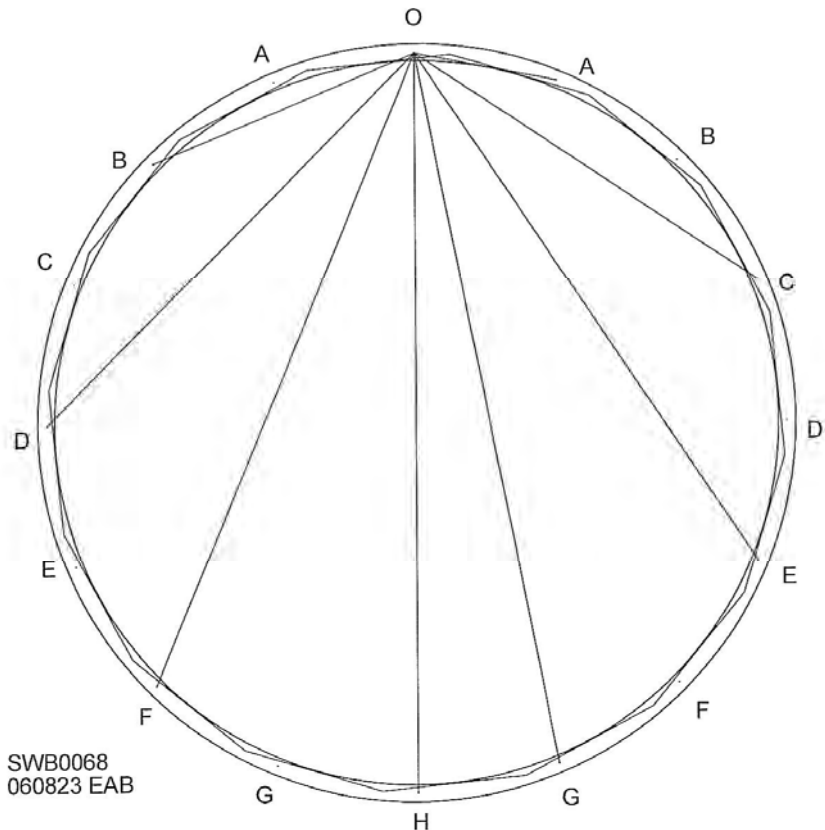

27' DIAMETER ANCHOR PLACEMENT

| POINT | DISTANCE |
|-------|--------------|
| A | 4' 9 1/16" |
| B | 9' 4 5/16" |
| C | 13' 8 3/16" |
| D | 17' 7 1/8" |
| E | 20' 11 5/8" |
| F | 23' 8 7/16" |
| G | 25' 8 5/8" |
| H | 26' 11 7/16" |
| I | 27' 4 7/16" |

CONCRETE RADIUS: See Chart
 ANCHOR RADIUS: 13' 8 3/16"
 BIN RADIUS: 13' 5 1/8"

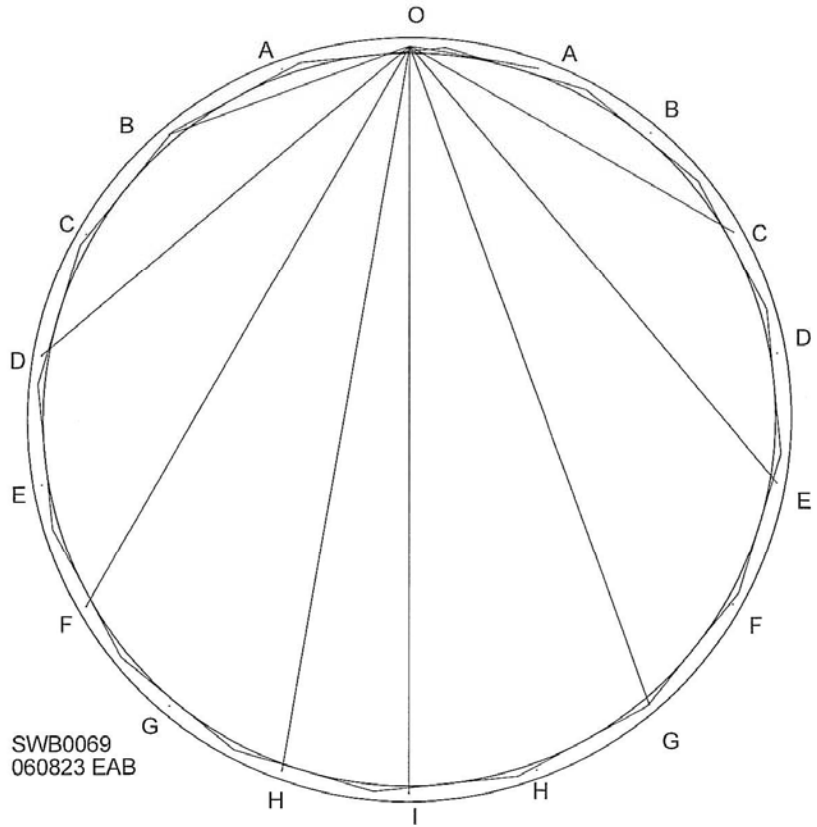

30' DIAMETER ANCHOR PLACEMENT

| POINT | DISTANCE |
|-------|--------------|
| A | 4' 9" |
| B | 9' 4 9/16" |
| C | 13' 9 3/8" |
| D | 17' 10 1/8" |
| E | 21' 5 9/16" |
| F | 24' 6 11/16" |
| G | 27' 9/16" |
| H | 28' 10 7/16" |
| I | 29' 11 3/4" |
| J | 30' 4 1/4" |

CONCRETE RADIUS: See Chart
 ANCHOR RADIUS: 15' 2 1/8"
 BIN RADIUS: 14' 11 1/32"

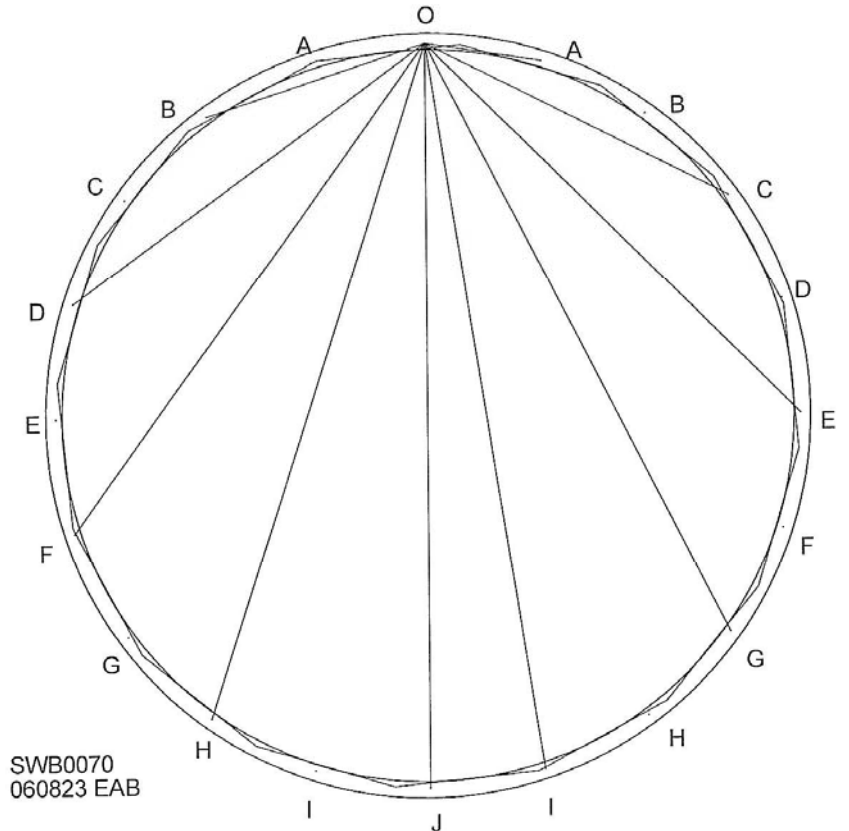

33' DIAMETER ANCHOR PLACEMENT

| POINT | DISTANCE |
|-------|--------------|
| A | 4' 8 15/16" |
| B | 9' 4 11/16" |
| C | 13' 10 3/16" |
| D | 18' 5/16" |
| E | 21' 10" |
| F | 25' 2 3/8" |
| G | 28' 9/16" |
| H | 30' 3 15/16" |
| I | 31' 11 7/8" |
| J | 33' |
| K | 33' 4 1/16" |

CONCRETE RADIUS: See Chart
 ANCHOR RADIUS: 16' 8"
 BIN RADIUS: 16' 4 15/16"

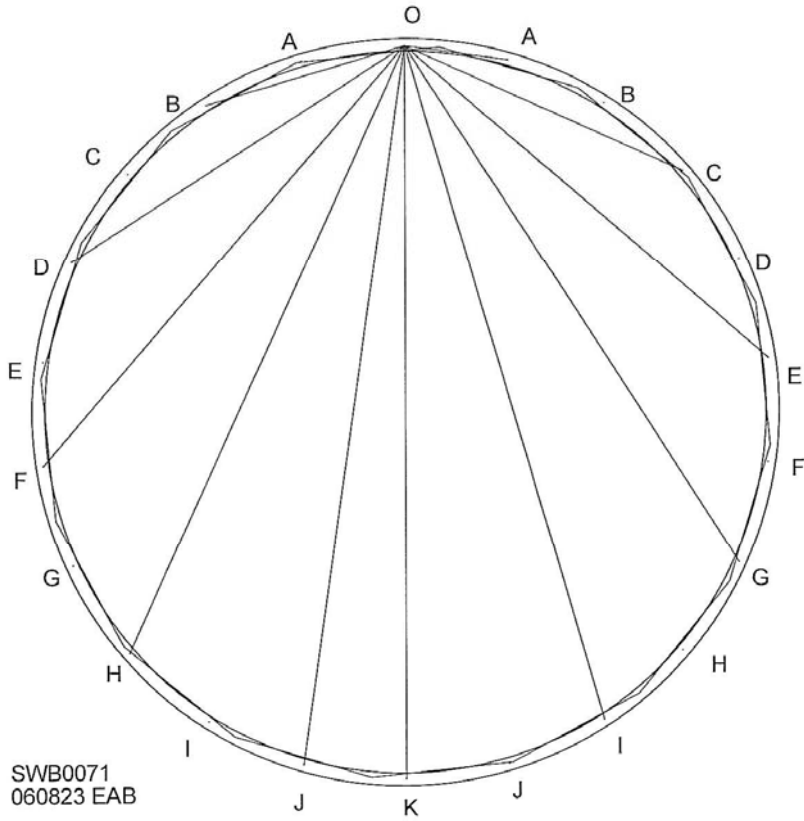

36' DIAMETER ANCHOR PLACEMENT

| POINT | DISTANCE |
|-------|---------------|
| A | 4' 8 7/8" |
| B | 9' 4 13/16" |
| C | 13' 10 13/16" |
| D | 18' 1 15/16" |
| E | 22' 1 3/8" |
| F | 25' 8 3/16" |
| G | 28' 9 13/16" |
| H | 31' 5 1/2" |
| I | 33' 6 11/16" |
| J | 35' 1" |
| K | 36' 1/8" |
| L | 36' 3 7/8" |

CONCRETE RADIUS: See Chart
 ANCHOR RADIUS: 18' 1 15/16"
 BIN RADIUS: 17' 10 7/8"

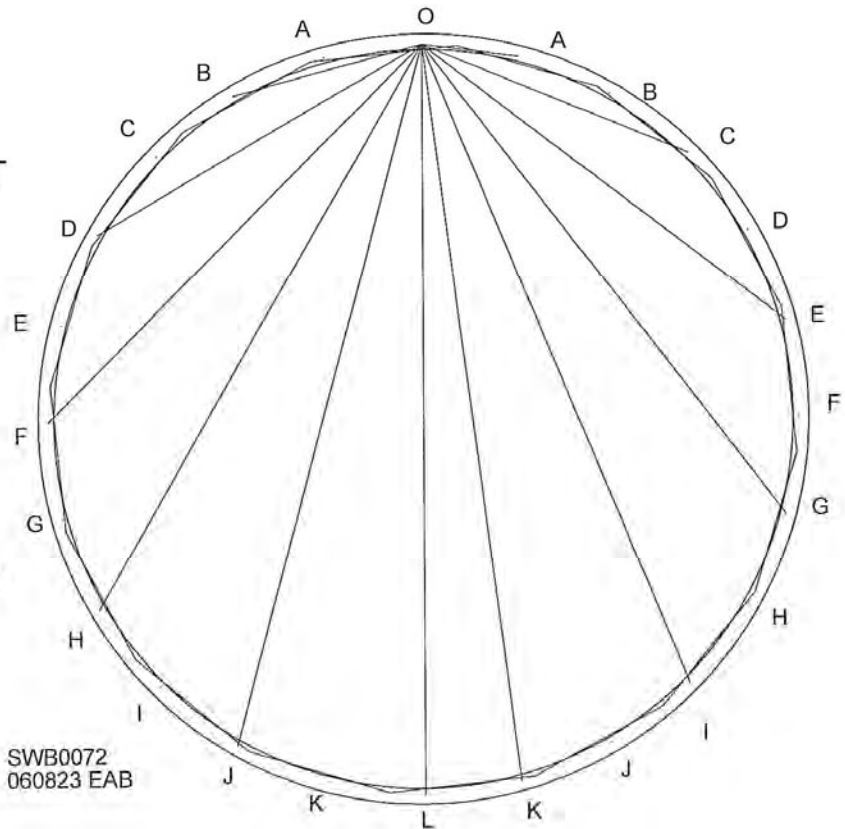

39' DIAMETER COMMERCIAL BIN ANCHOR PLACEMENT

| POINT | DISTANCE |
|-------|--------------|
| A | 4' 8 7/8" |
| B | 9' 4 7/8" |
| C | 13' 11 1/4" |
| D | 18' 3 3/16" |
| E | 22' 3 15/16" |
| F | 26' 13/16" |
| G | 29' 5 1/16" |
| H | 32' 4 3/16" |
| I | 34' 9 11/16" |
| J | 36' 9 1/16" |
| K | 38' 2" |
| L | 39' 1/4" |
| M | 39' 3 11/16" |

CONCRETE RADIUS: SEE CHART
ANCHOR RADIUS: 19' 7 7/8"
BIN RADIUS: 19' 4 3/4"

SWB0264
03/26/2012 EAB

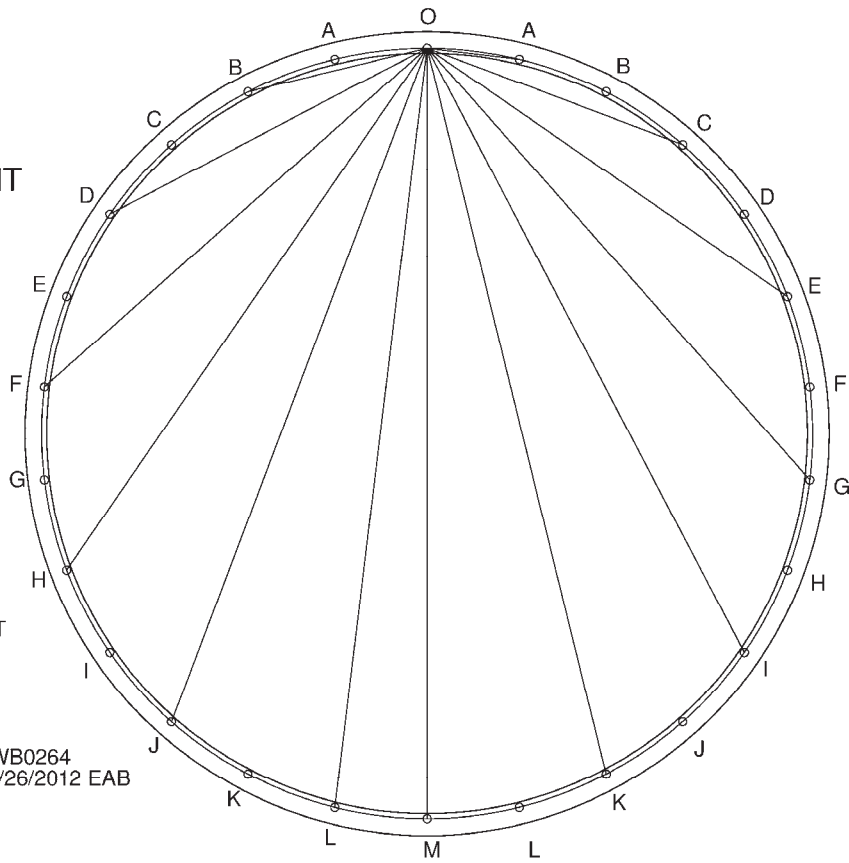

42' DIAMETER ANCHOR PLACEMENT

| POINT | DISTANCE |
|-------|--------------|
| A | 4' 8 13/16" |
| B | 9' 4 15/16" |
| C | 13' 11 5/8" |
| D | 18' 4 3/16" |
| E | 22' 6" |
| F | 26' 4 7/16" |
| G | 29' 10 7/8" |
| H | 33' 3/4" |
| I | 35' 9 11/16" |
| J | 38' 1 1/4" |
| K | 39' 11" |
| L | 41' 2 3/4" |
| M | 42' 5/16" |
| N | 42' 3 1/2" |

CONCRETE RADIUS: See Chart
ANCHOR RADIUS: 21' 1 3/4"
BIN RADIUS: 20' 10 11/16"

SWB0073
060823 EAB

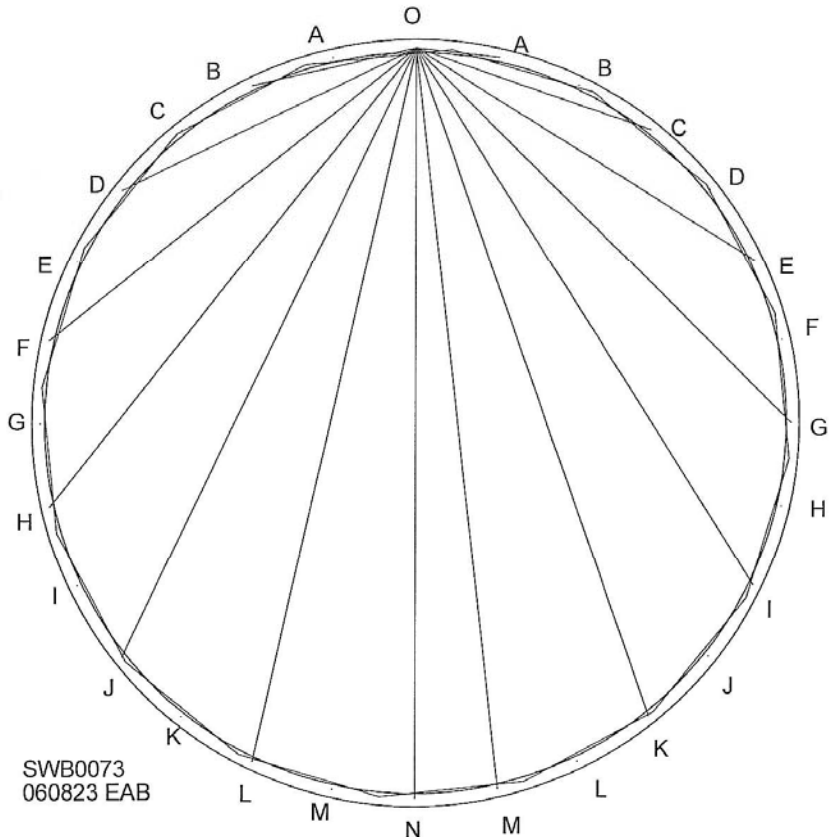

45' DIAMETER ANCHOR PLACEMENT

| POINT | DISTANCE |
|-------|-------------|
| A | 4' 8 13/16" |
| B | 9' 4 15/16" |
| C | 13' 11 7/8" |
| D | 18' 5" |
| E | 22' 7 5/8" |
| F | 26' 7 5/16" |
| G | 30' 3 1/2" |
| H | 33' 7 3/4" |
| I | 36' 7 1/2" |
| J | 39' 2 1/2" |
| K | 41' 4 5/16" |
| L | 43' 11/16" |
| M | 44' 3 3/8" |
| N | 45' 5/16" |
| P | 45' 3 1/4" |

CONCRETE RADIUS: See Chart
 ANCHOR RADIUS: 22' 7 5/8"
 BIN RADIUS: 22' 4 9/16"

SWB0285
 03/26/2013 EAB

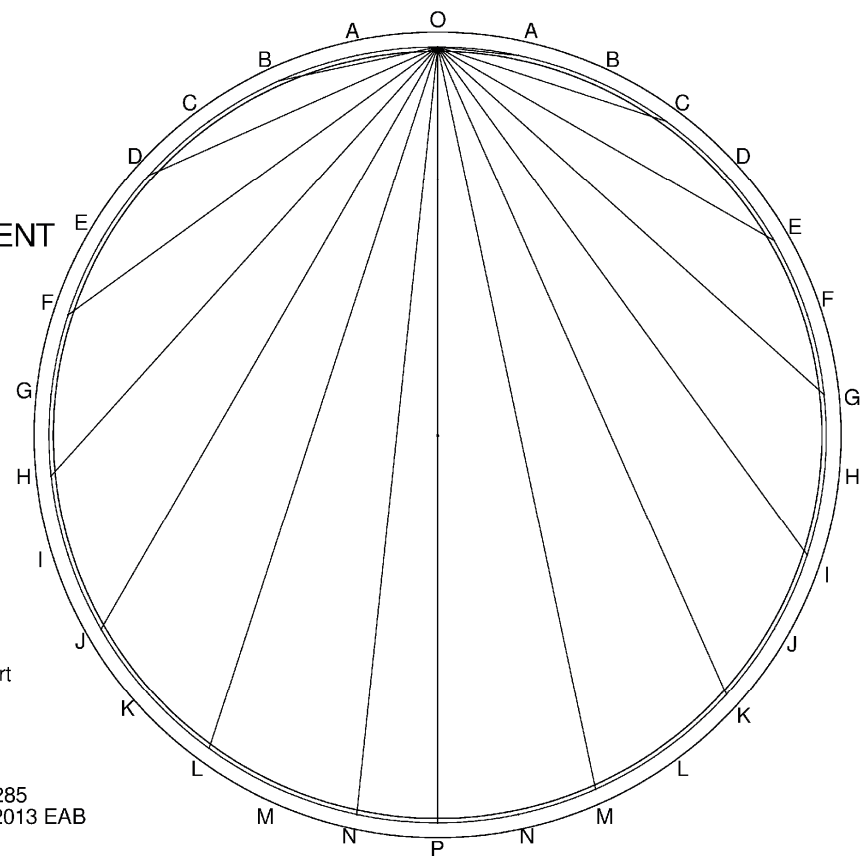

48' DIAMETER ANCHOR PLACEMENT

| POINT | DISTANCE |
|-------|--------------|
| A | 4' 8 3/4" |
| B | 9' 5" |
| C | 14' 1 1/16" |
| D | 18' 5 5/8" |
| E | 22' 8 15/16" |
| F | 26' 9 11/16" |
| G | 30' 7 3/8" |
| H | 34' 1 7/16" |
| I | 37' 3 5/8" |
| J | 40' 1 1/2" |
| K | 42' 6 11/16" |
| L | 44' 7" |
| M | 46' 2 1/8" |
| N | 47' 3 15/16" |
| P | 48' 1/4" |
| Q | 48' 3 1/16" |

CONCRETE RADIUS: See Chart
 ANCHOR RADIUS: 24' 1 1/2"
 BIN RADIUS: 23' 10 1/2"

SWB0074
 060823 EAB

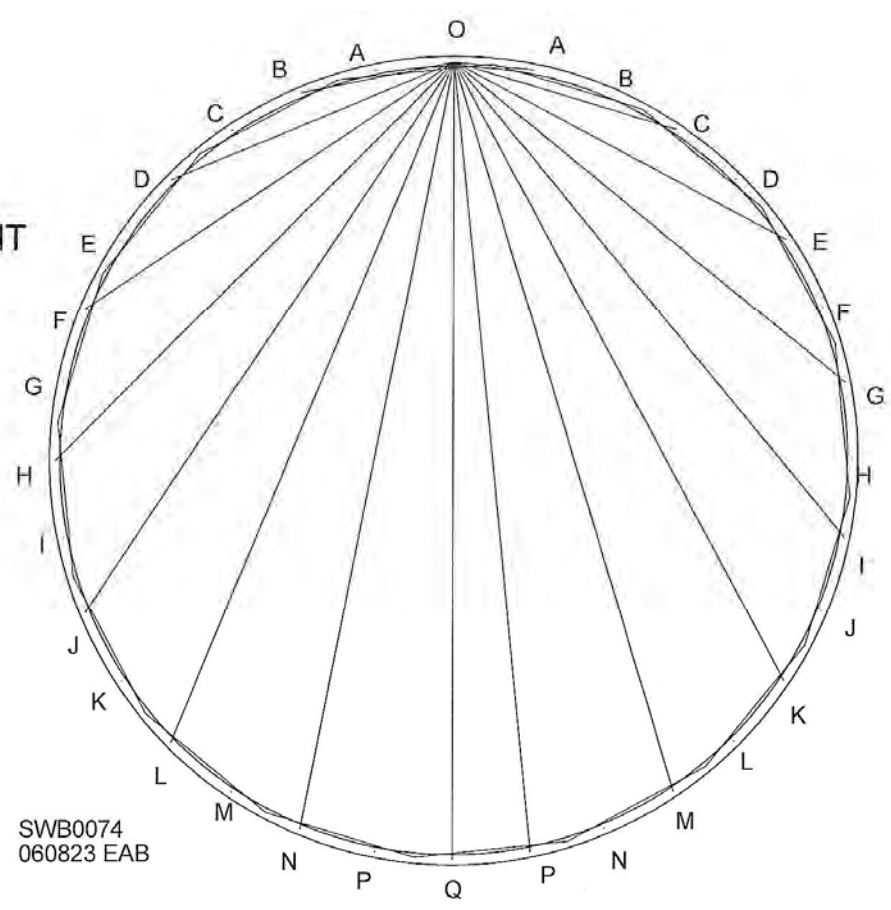

Farm Bin Anchor Bolt Guidelines

- Based on ASCE 7-10 Code, 105 mph wind zone -

A qualified geotechnical engineer should review all foundation specifications, including anchor bolt layout, to ensure foundation design is compatible with maximum load-bearing capacity of soil and with any other environmental factors at bin location.

Tables on next page are provided as general guidance for minimum anchor bolt requirements (diameter and depth in concrete). Pull-out force depends on diameter of anchor. Mechanical drill and drive anchors require ultimate pull-out strength of 7,500 lbs. for 5/8" and 10,000 lbs. for 3/4" anchor bolts. Be certain to follow anchor bolt manufacturer's detailed installation instructions to prevent any uplift. Also, it is important these guidelines be followed to ensure proper anchoring:

- Concrete pad must be allowed to cure for a minimum of 28 days prior to anchoring of bin.
- Unless otherwise noted by anchor bolt manufacturer, holes must be cleaned by using a wire brush and air to blow out dust. Cleaning hole will minimize slippage after wedge/epoxy anchor is set.
- Nuts on anchors must be tightened to manufacturer's specifications to withstand uplift.

Drawing below shows types of anchors used. At left are two different types of cast-in-place anchor: an "L" style and a "W & N" (washer and nut) style. At right are two different post-installed anchors: a mechanical drill and drive style and a drill and epoxy style.

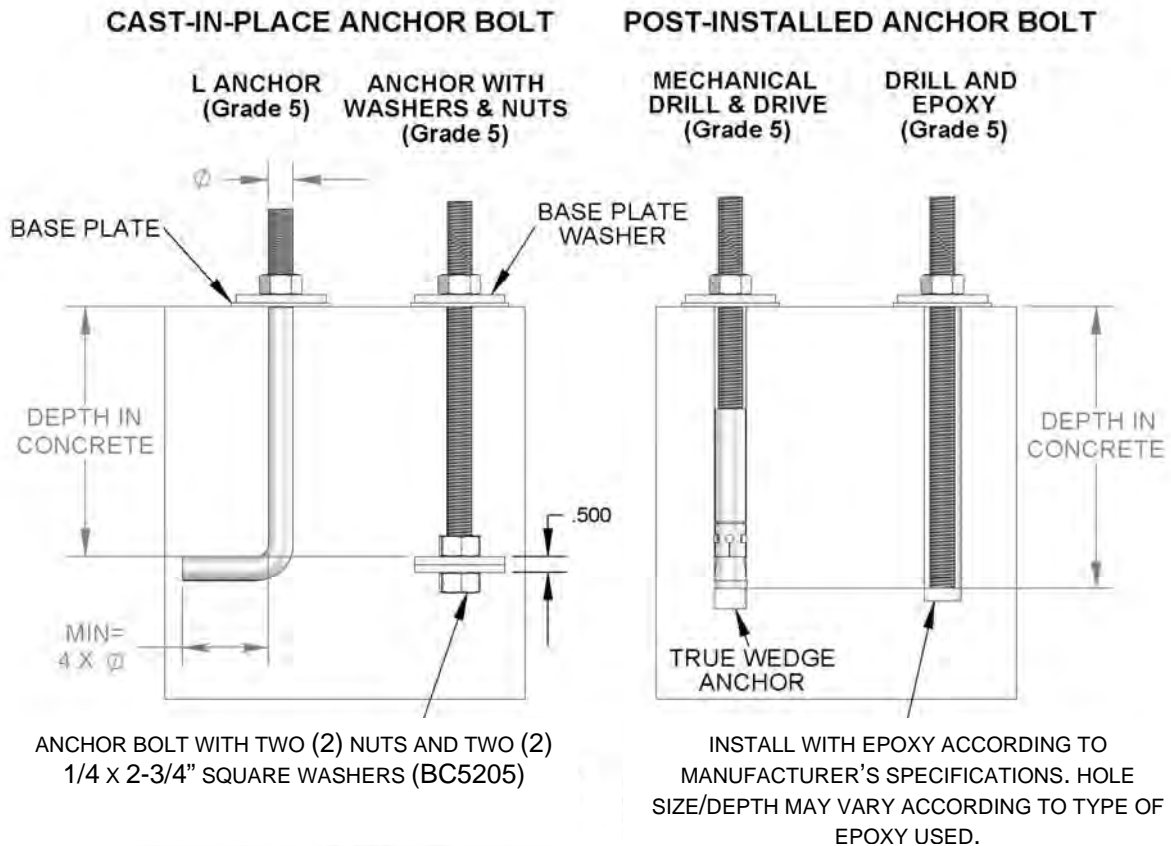

Farm Bin Anchors

| Bin DIA. | Ring Height | Types of Anchors (in DIA)* | | | Depth In Concrete | Washer Qty. Per Anchor (in bin box) | | |
|----------|-------------|----------------------------|---------------|--------------------------|-------------------|-------------------------------------|-----------------|-----------------|
| | | Cast In Place | Drill & Epoxy | Mechanical Drill & Drive | | 2-3/4" x 3-1/2" BS52082 | 5/8" Flat J1127 | 3/4" Flat J1130 |
| 15' | 3 - 6 | 5/8" L | 5/8" | 5/8" | 6-1/2" | 1 | 1 | - |
| | 7 - 9 | 3/4" L | 3/4" | N/R** | 8" | 1 | - | 1 |
| 18' | 3 - 7 | 5/8" L | 5/8" | 5/8" | 6-1/2" | 1 | 1 | - |
| | 8 - 10 | 3/4" L | 3/4" | N/R** | 8" | 1 | - | 1 |
| 21' | 3 - 7 | 5/8" L | 5/8" | 5/8" | 6-1/2" | 1 | 1 | - |
| | 8 - 10 | 3/4" L | 3/4" | N/R** | 8" | 1 | - | 1 |
| 24' | 3 - 7 | 5/8" L | 5/8" | 5/8" | 6-1/2" | 1 | 1 | - |
| | 8 - 10 | | | N/R** | 8" | 1 | - | 1 |
| 27' | 3 - 7 | 5/8" L | 5/8" | 5/8" | 6-1/2" | 1 | 1 | - |
| | 8 - 10 | | | N/R** | 8" | 1 | - | 1 |
| 30' | 3 - 7 | 3/4" L | 3/4" | 3/4" | 8" | 1 | - | - |
| | 8 - 10 | | | N/R** | | | | |
| 33' | 3 - 7 | 3/4" L | 3/4" | 3/4" | 8" | 1 | - | - |
| | 8 - 10 | | | N/R** | | | | |
| 36' | 3 - 9 | 3/4" L | 3/4" | 3/4" | 8" | 1 | - | - |
| | 10 | | | N/R** | | | | |
| 42' | 3 - 9 | 3/4" L | 3/4" | 3/4" | 8" | 1 | - | - |
| | 10 | | | N/R** | | | | |
| 48' | 3 - 10 | 3/4" L | 3/4" | 3/4" | 8" | 1 | - | - |

*Refer to previous page for anchor types ("L" refers to shape of anchor).

Mechanical drill & drive anchors **NOT RECOMMENDED by Sukup Manufacturing Co.

Farm Stiffened Bin Anchors

| Bin DIA. | Ring Height | Types of Anchors (in DIA)* | | | Depth In Concrete | Washer Qty. Per Anchor (in bin box) | |
|----------|-------------|----------------------------|---------------|--------------------------|-------------------|-------------------------------------|-----------------|
| | | Cast In Place | Drill & Epoxy | Mechanical Drill & Drive | | 2-3/4" x 3-1/2" Rec. BS52082 | 5/8" Flat J1127 |
| 15' | 5 - 7 | 5/8" L | 5/8" | 5/8" | 6-1/2" | 1 | 1 |
| | 8 - 9 | 3/4" W & N | 3/4" | N/R** | 8" | 2 | - |
| 18' | 5 - 7 | 5/8" L | 5/8" | 5/8" | 6-1/2" | 1 | 1 |
| | 8 - 9 | 3/4" W & N | 3/4" | N/R** | 8" | 2 | - |
| 21' | 5 - 8 | 5/8" L | 5/8" | 5/8" | 6-1/2" | 1 | 1 |
| | 9 - 10 | 3/4" L | 3/4" | N/R** | 8" | 2 | - |
| 24' | 5 - 8 | 5/8" L | 5/8" | 5/8" | 6-1/2" | 1 | 1 |
| | 9 - 10 | 3/4" L | 3/4" | N/R** | 8" | 2 | - |
| 27' | 5 - 8 | 5/8" L | 5/8" | 5/8" | 6-1/2" | 1 | 1 |
| | 9 - 10 | 3/4" L | 3/4" | N/R** | 8" | 2 | - |
| 30' | 5 - 8 | 5/8" L | 5/8" | 5/8" | 6-1/2" | 1 | 1 |
| | 9 - 11 | 3/4" L | 3/4" | N/R** | 8" | 2 | - |
| 33' | 5 - 8 | 3/4" L | 3/4" | 3/4" | 8" | 1 | - |
| | 9 - 12 | 3/4" L | 3/4" | N/R** | 8" | 2 | |
| 36' | 5 - 8 | 3/4" L | 3/4" | 3/4" | 8" | 1 | - |
| | 9 - 12 | 3/4" L | 3/4" | N/R** | 8" | 2 | |
| 42' | 5 - 8 | 3/4" L | 3/4" | 3/4" | 8" | 1 | - |
| | 9 - 12 | 3/4" L | 3/4" | N/R** | 8" | 2 | |
| 48' | 5 - 9 | 3/4" L | 3/4" | 3/4" | 8" | 1 | - |
| | 10 - 12 | 3/4" L | 3/4" | N/R** | 8" | 2 | |

* Refer to previous page for anchor types ("L" refers to shape of anchor, "W & N" to washer and nut).

** Mechanical drill & drive anchors **NOT RECOMMENDED** by Sukup Manufacturing Co.

15' - 48' 5K Roof Assembly

Prior to assembly of roof it will be necessary to assemble first (top) ring of bin sidewall. Refer to sidewall assembly section of this manual for proper instructions. **NOTE:** For best results, unless otherwise specified, leave all bolts loose until roof assembly is complete. When tightening 3/8" bolts, torque to 25-35 ft.-lbs. For ease of construction, assemble apron on a flat surface.

IMPORTANT: At no time should any bolts be substituted for those supplied by Sukup Manufacturing Co.

DISCLAIMER: Roof is non load-bearing. It is not designed to support catwalks or accessories other than vents and roof ladder rungs.

Eave Clip Assembly

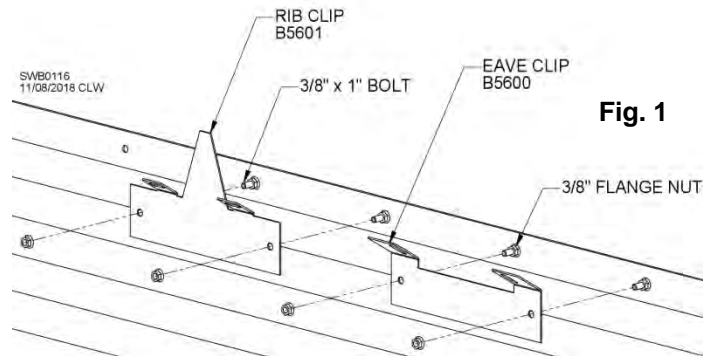

Install eave clips on top horizontal bolt holes around sidewall ring. Eave clips are to be installed on **inside** of bin sidewall as shown in Fig. 1. Begin by installing 3/8 x 1" bolts in every hole and tighten with 3/8" flange nuts. Continue installing eave clips, alternating from a rib clip to an intermediate clip, and fastening in place with 3/8" flange nuts. **NOTE:** When installing first clip, make certain of location. If started incorrectly, manhole door and roof ladder may not line up properly.

Attachment of Continuous Eave Clip (Y Option) or Louvered Eave Vent (A Option)

IMPORTANT: Use continuous eave clip on hopper bins.

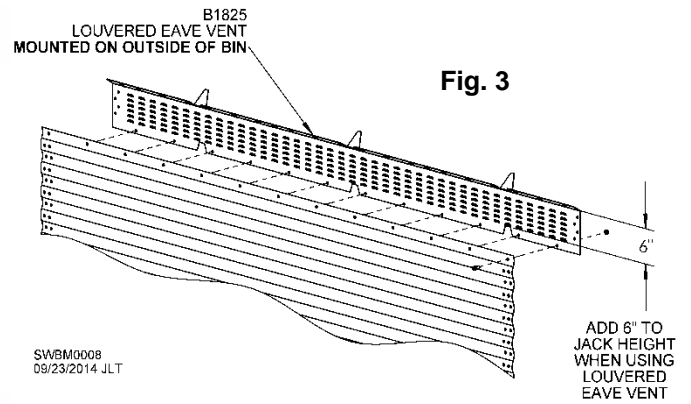
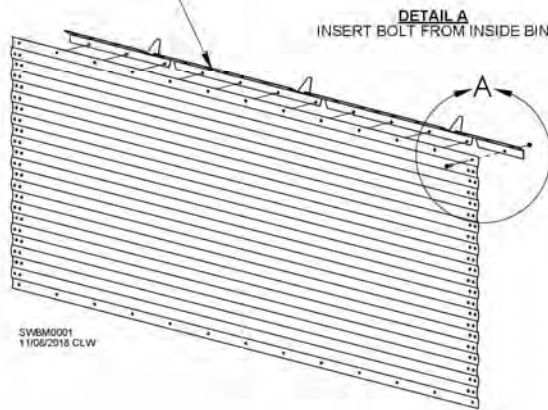
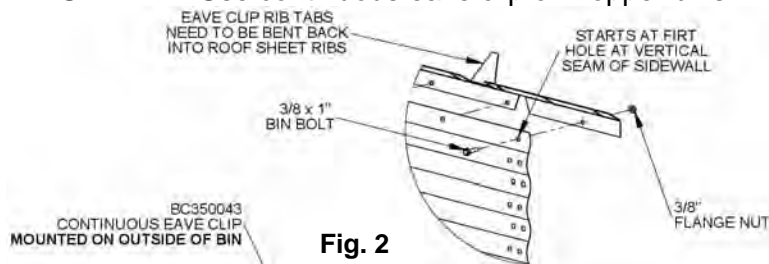

Attach continuous eave clip or louvered eave vent to top row of holes on **outside** of each bin sidewall sheet as shown in Fig. 2 or Fig. 3. Fasten with 3/8 x 1" bin bolts and 3/8" flange nuts. Insert bolts from inside of bin. Rib tabs can be bent back into roof sheet rib after all roof sheets have been assembled to peak ring and eave clip.

Peak Ring Apron Assembly

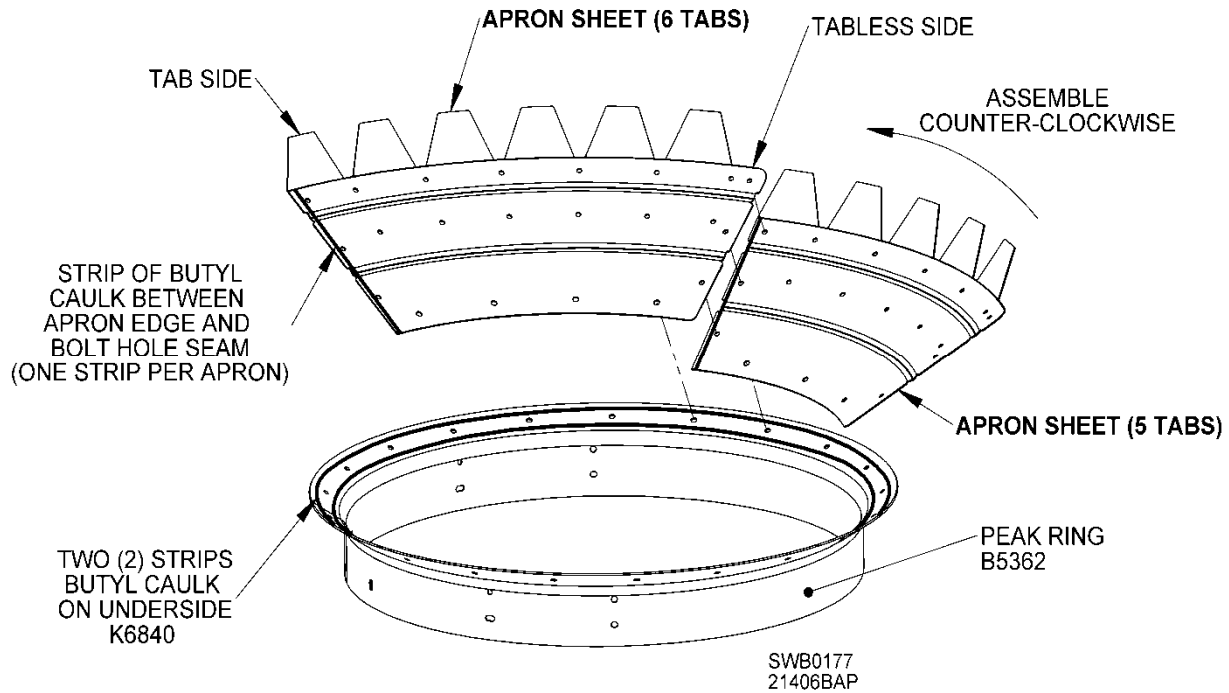

Fig. 4

Locate peak ring. Apply caulk to underside of flange, one strip above bolt holes and one strip below, around entire circumference. See Fig. 4.

Table 1 shows number of peak ring apron pieces used for each size of bin, number of tabs per apron piece and, where applicable, number of each piece to use.

Table 1

| BIN DIA. | # OF APRONS | # OF TABS/APRON (# OF EACH) |
|----------|-------------|--------------------------------|
| 15' | 6 | 3 (3), 2 (3) |
| 18' | 6 | 3 |
| 21' | 7 | 3 |
| 24' | 6 | 4 |
| 27' | 6 | 5 (3), 4 (3) |
| 30' | 6 | 5 |
| 33' | 6 | 6 (3), 5 (3) |
| 36' | 6 | 6 |
| 39' | 6 | 7 (3), 6 (3) |
| 42' | 6 | 7 |
| 48' | 6 | 8 |

On tab side of apron, apply a strip of caulk between apron edge and bolt seam as shown in Fig. 4. **IMPORTANT:** There are more holes than needed to align apron pieces to peak ring. Fill all necessary holes. Attach first apron piece to underside of peak ring with 5/16 x 1-1/4" bin bolts and 5/16" flange nuts. Working counterclockwise, overlap apron pieces and fasten seams using 5/16 x 1-1/4" bin bolts and 5/16" flange nuts. Tableless side of apron pieces will always overlap tab side. See Fig. 4. Continue fastening apron pieces and complete assembly of apron to peak ring.

Peak Stiffening Ring Assembly (39', 42', & 48' bins)

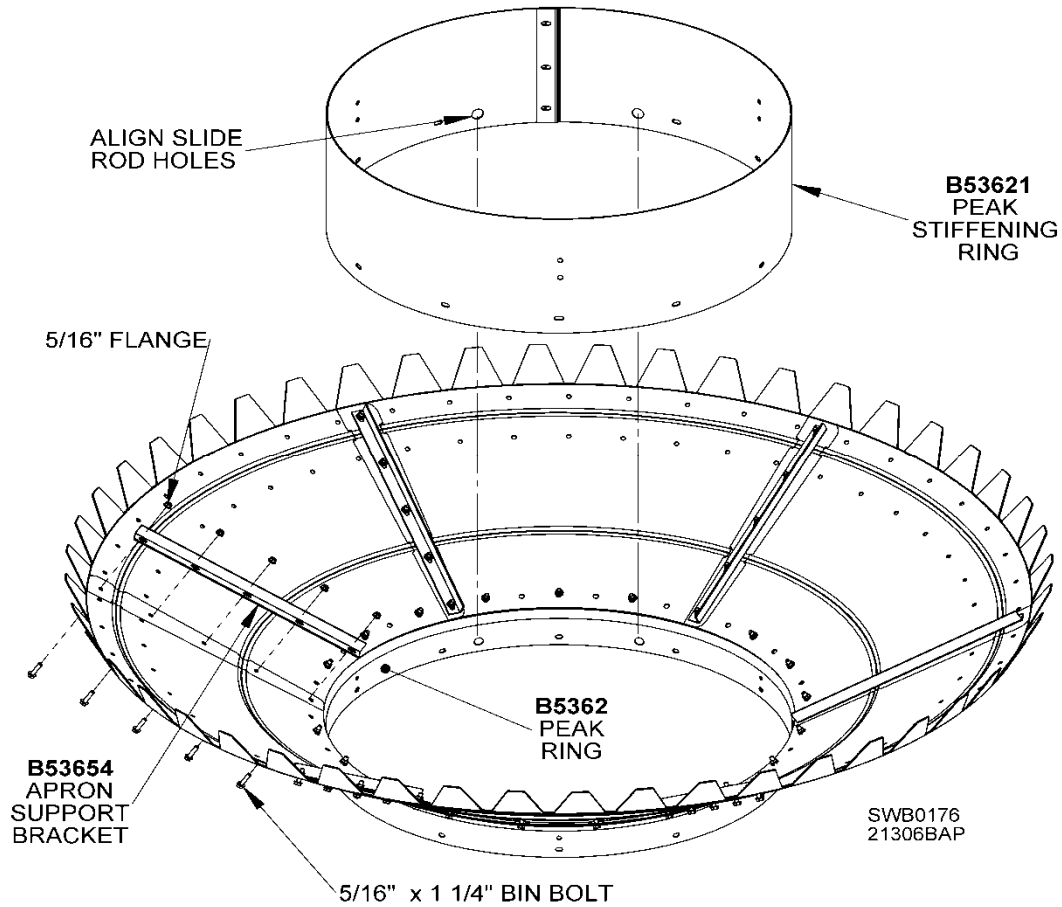
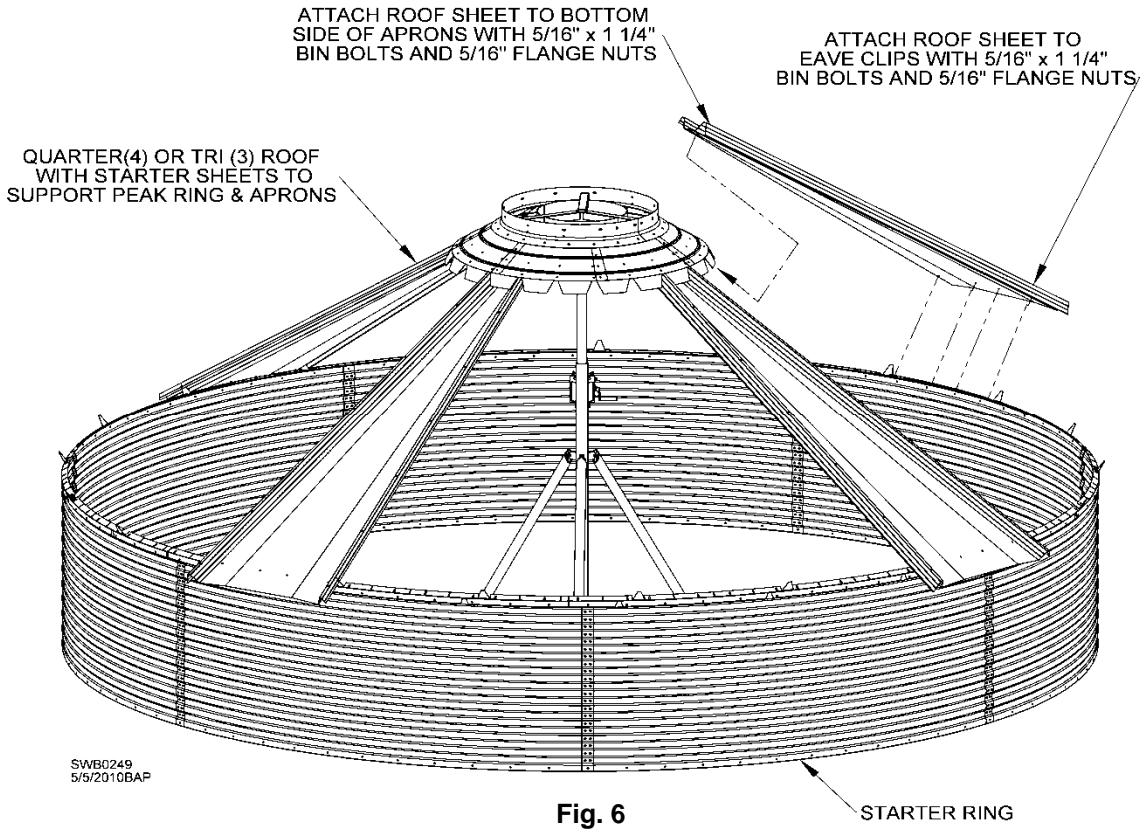

Fig. 5

On 39', 42' and 48' diameter bins and all bins with a stirring machine, a peak stiffening ring is used. **NOTE:** If peak stiffening ring is used, hardware must be tightened at apron-to-peak-ring connection before peak stiffening ring can be attached. This will allow flange nut access from inside to ensure a watertight seal. Connect peak stiffening ring to peak ring with (12) 5/16 x 1-1/4" bin bolts and 5/16" flange nuts. See Fig. 5. Ensure slide rod holes line up in peak ring and peak stiffening ring.

On 42' and 48' diameter bins, apron support brackets are used to provide greater strength. Assemble apron support brackets on underside of aprons at every seam using 5/16 x 1-1/4" bin bolts and 5/16" flange nuts. See Fig. 5.

Initial Roof Sheet Assembly



Place support jack in center of sidewall ring. See Table 2 for approximate height setting. This height is a starting point. Peak ring may need to be raised or lowered to ensure that holes in roof sheets match up with holes in eave clips. **NOTE:** An **adjustable** center support jack will allow for incremental adjustments, making assembly of roof to eave clips easier. See Fig. 6.

| Bin Diameter | Approx. 5K Roof Peak Ring Height |
|--------------|----------------------------------|
| 15' | 8' |
| 18' | 8' 11" |
| 21' | 9' 11" |
| 24' | 11' |
| 27' | 11' 9" |
| 30' | 12' 8" |
| 33' | 13' 7" |
| 36' | 14' 11" |
| 39' | 15' 8" |
| 42' | 16' 5" |
| 48' | 18' 3" |

NOTE: Measurements must be taken from foundation to top of peak ring.

NOTE: Raise jack height by 6" if using louvered eave vent.

Table 2

If possible, fasten peak ring to center support jack using upper horizontal slots. Position holes for peak ring cap slide rods to be opposite of intended location of roof ladder. This will permit peak ring cap to slide away from roof ladder when cap is opened for filling bin.

Begin roof assembly by installing four (4) individual roof panels, placing them directly opposite each other so roof is quartered as shown in Fig. 6. Use 5/16 x 1-1/4" bolts and 5/16" flange nuts.

Roof Sheet Assembly

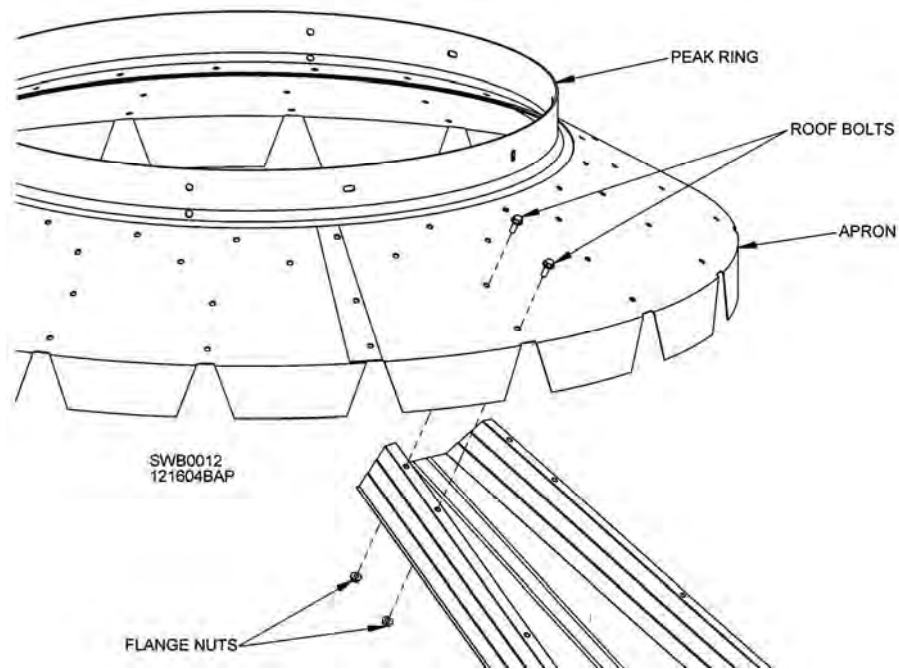

Fig. 7

Attach top of roof panel beneath peak ring and apron using two (2) 5/16 x 1-1/4" bolts and 5/16" flange nuts. See Fig. 7. Leave bolts out of right-hand rib at top (viewing panel from outside of sidewall ring). This will allow assembly in **counterclockwise** direction. Leaving this rib loose will allow next roof panel to slide into place.

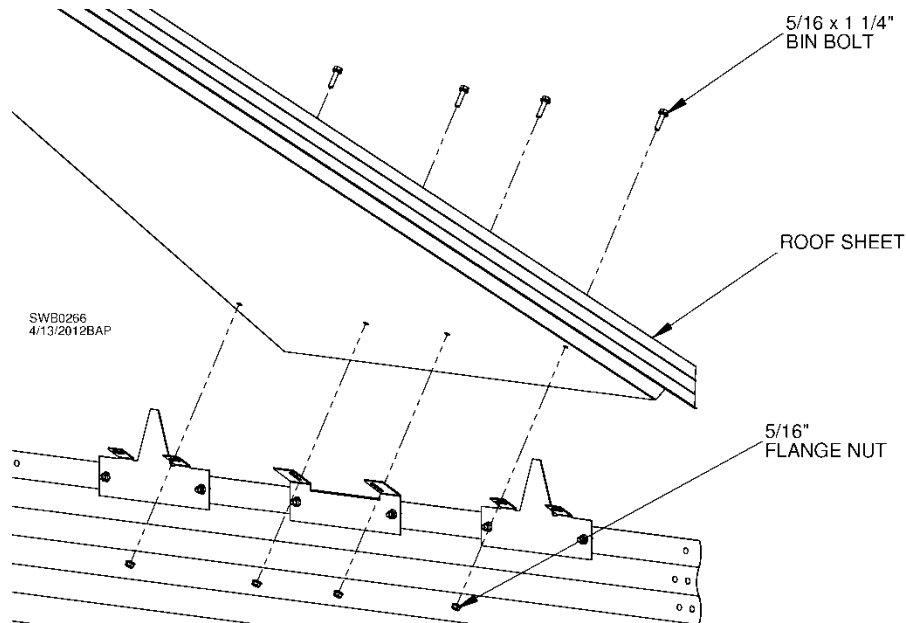
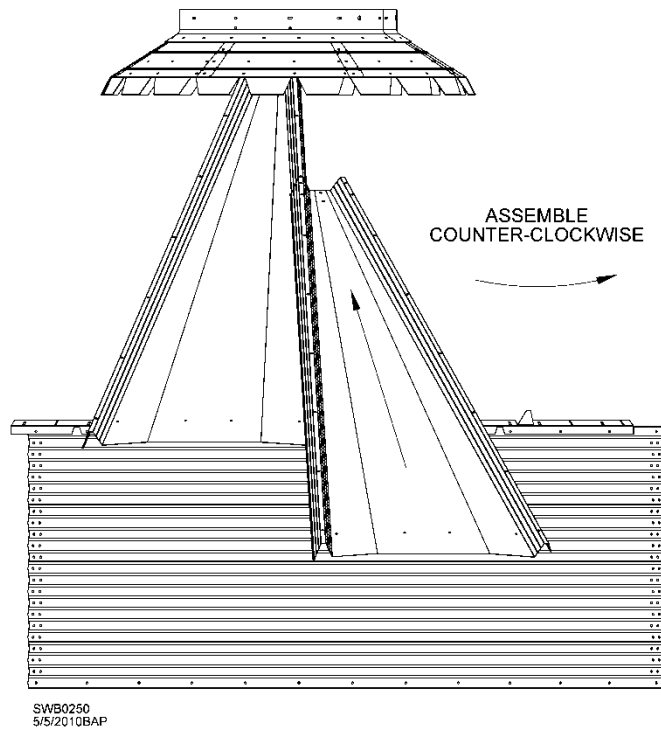

Fig. 8

Fasten bottom of roof panel to eave clips (shown in Fig. 8), or to continuous eave clip or louvered roof vent (see Figs. 2 or 3) using 5/16 x 1-1/4" bolts and 5/16" flange nuts. Leave bolt closest to left-hand rib out. Rib will be lifted later for assembly of last roof panel in section.

Fig. 9



Slide next roof panel into place, overlapping ribs as shown in Fig. 9. Lay panel flat when sliding it up roof to prevent gouging of roof panel already in place. Place two (2) or three (3) panels in each section, then move to opposite side and do same. Fasten panels to apron and continuous eave clip or louvered roof vent using 5/16 x 1-1/4" bolts and 5/16" flange nuts. Lift starter sheet to install last panel in each section. Add bent roof ring brackets at appropriate locations with openings toward peak ring. See Table 5 for locations of bent roof ring brackets. **NOTE:** 39', 42' and 48' diameter bins have two (2) roof rings. An exception is 48' Sukup Europe bin, which has three (3) rings. See Table 5.1.

Assemble roof ladder rungs on designated roof sheets. Install 5/16 x 1-1/4" bolts and 5/16" flange nuts in all rib holes.

Roof Ladder Rungs and Bent Roof Ring Brackets

Roof ring brackets and roof ladder rungs are attached to roof sheets using 5/16 x 1-1/4" bolts, 5/16" flange nuts, and neoprene washers. See Fig. 10. Washers slip onto bolts that have been inserted through roof ladder rungs and will be compressed between roof sheet rib and roof ladder rung to ensure watertight seal. See Fig. 10. Roof ring bracket, roof ring, and U-bolt assemblies are shown in Figs. 14 and 15.

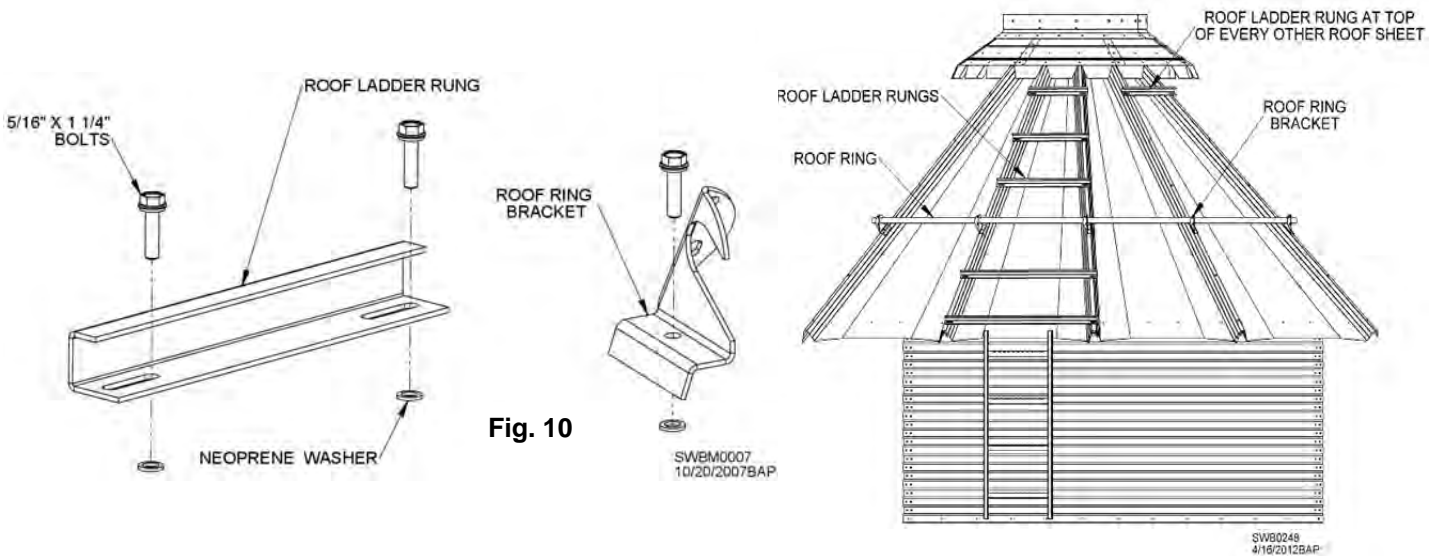

Roof Ladder Support Assembly

Assemble roof ladder rungs and peak walk-around rungs as roof panels are put into place. Place walk-around rungs over every other panel as shown at right in Fig. 10. **NOTE:** Use an extra seal washer (supplied) on any bolt between an accessory panel and a roof panel. This includes roof ladder rungs, bent roof ring brackets and peak walk-around rungs. Washers will provide better protection against leakage.

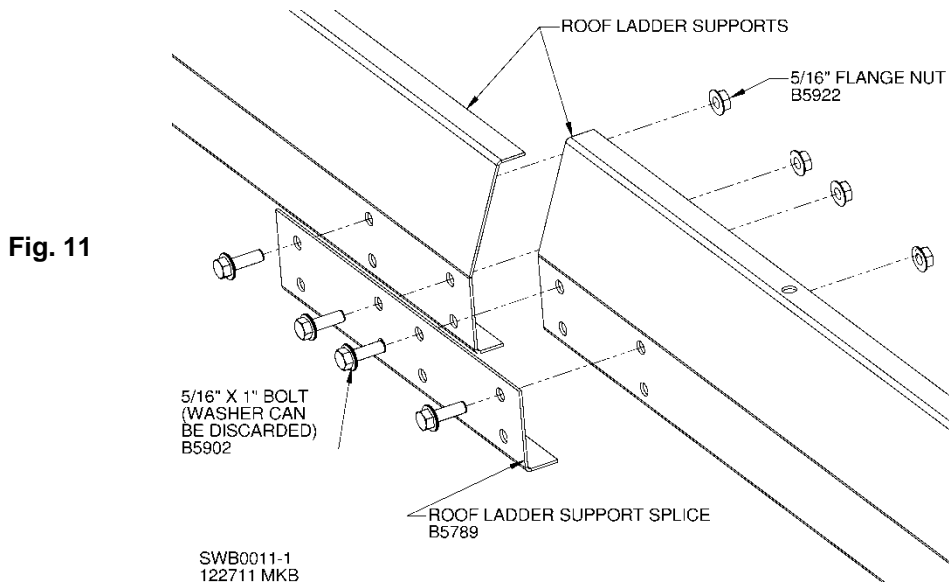

When assembling roof ladder rungs on 36' diameter and larger bins, also install a roof ladder support on underside of roof. Splice roof ladder supports as shown in Fig. 11 using 5/16 x 1" bolts and 5/16" flange nuts. Seal washer is not required and may be discarded.

Roof ladder supports will attach starting on second hole from bottom on underside of roof rib. Roof ladder supports and roof ladder rungs are assembled simultaneously using 5/16 x 1-1/4" bolts and 5/16" flange nuts. See Table 3 for roof ladder support specifications.

Table 3

| Bin Diameter | QTY./Rib | Part # | Roof Ladder Support Length |
|--------------|----------|--------|----------------------------|
| 36' | 1 | B5791 | 82.252" |
| | 1 | B5792 | 102.815" |
| 39' | 2 | B5792 | 102.815" |
| 42' | 1 | B5790 | 61.689" |
| | 2 | B5791 | 82.252" |
| 48' | 1 | B5790 | 61.689" |
| | 2 | B5792 | 102.815" |

Roof Ladder Support Bracket Specifications

| Bin Diameter | # of Splices Required |
|--------------|-----------------------|
| 36' | 1-Splice |
| 39' | 1 Splice |
| 42', 48' | 2 Splices |

15', 18', 21', 24', 27', 30' and 33' diameter bins do not require Roof Ladder Support Brackets. Omit ladder rungs where roof ring(s) will interfere.

Slide last roof panel of each section into place by lifting starting panel.

1/8" Foam Sealant and Inner Shield

Fig. 12

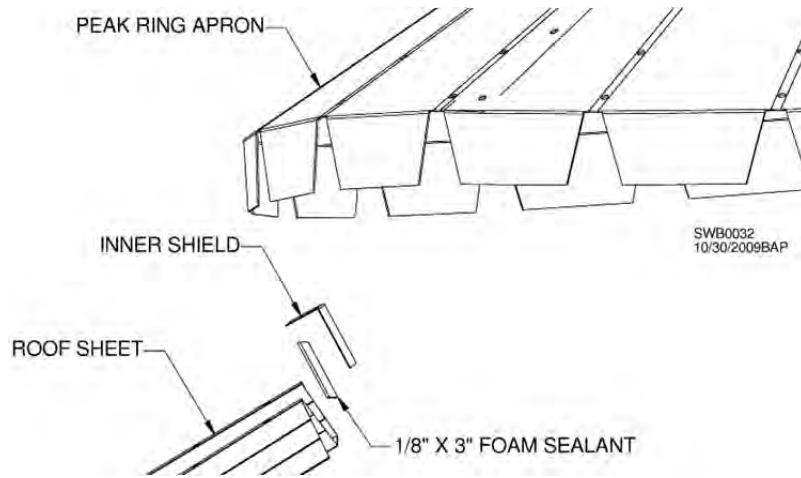

When all roof panels and bolts are in place, install foam sealant and inner shields on ends of roof panels under roof apron. See Fig. 12. Roll of foam sealant may be longer than needed. Unroll foam sealant around inside of roof panel ends and cut to appropriate length. **TIP:** Once length has been determined, it may be easier to cut foam sealant to same length as flashing. Sealant can then be applied to each piece of flashing.

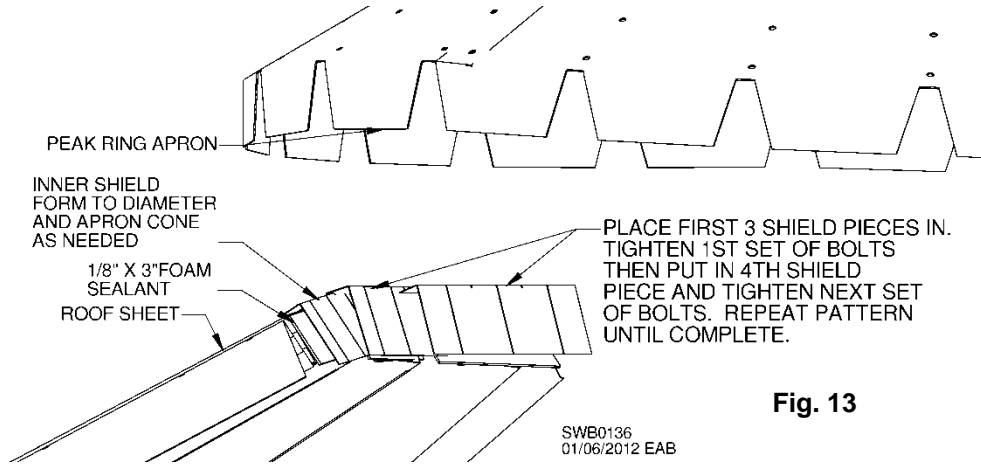

Fig. 13

As shown in Fig. 13, insert three (3) shield pieces, then tighten bolts on first installed piece. Install fourth piece and tighten next set of bolts. Continue pattern until all inner shields are installed. See Table 4 for quantity of peak ring inner shields. **TIP:** After shield pieces are put into place, run a self-tapping screw through every overlapped location. This will tie pieces together and secure them in place.

| Bin Diameter | Shield piece QTY. |
|--------------|-------------------|
| 15' - 36' | 15 |
| 42' - 48' | 20 |

Table 4 – Quantity of peak ring inner shield pieces, Part # B53653

Tighten all 5/16" flange nuts to 15 to 20 ft-lbs. Using a soft-faced mallet, bend down tabs on apron until contact is made with roof panel.

External Roof Ring Attachment

See Table 5 for quantities of roof ring components based on bin diameter. Bent roof ring brackets should have been fastened at locations specified in Table 5 during assembly of roof panels.

Table 5 – Quantities of roof ring components

| Bin Dia. | Bent Bracket, Roof Ring Location* | Internal Tube Splices | Expanders | 10' Pieces ** | U-Bolts | External Splice Tubes |
|----------|-----------------------------------|-----------------------|-----------|---------------|---------|-----------------------|
| 18' | 3 | 1 | 2 | 4 | 18 | 1 |
| 21' | 3 | 2 | 2 | 5 | 21 | 1 |
| 24' | 4 | 2 | 2 | 5 | 24 | 1 |
| 27' | 4 | 2 | 3 | 6 | 27 | 1 |
| 30' | 5 | 2 | 3 | 6 | 30 | 1 |
| 33' | 5 | 3 | 3 | 7 | 33 | 1 |
| 36' | 5 | 3 | 4 | 8 | 36 | 1 |
| 39' | 5 | 4 | 4 | 9 | 39 | 1 |
| | 7 | 3 | 3 | 7 | 39 | 1 |
| 42' | 5 | 4 | 5 | 10 | 42 | 1 |
| | 10*** | 2 | 3 | 6 | 42 | 1 |
| 48'**** | 6 | 5 | 5 | 11 | 48 | 1 |
| | 11 | 2 | 3 | 6 | 48 | 1 |

* Location determined by counting holes from bottom edge (eave) of roof sheet.

** Roof ring pieces are factory-rolled for intended location.

*** If using tapered roof vent on 42' bin, upper ring must be at 9th hole from eave instead of 10th.

****48' Sukup Europe bins require three roof rings. See Table 5.1 below

| | | | | | | |
|-----|----|---|---|----|----|---|
| 48' | 4 | 6 | 6 | 13 | 48 | 1 |
| | 6 | 5 | 5 | 11 | 48 | 1 |
| | 11 | 2 | 3 | 6 | 48 | 1 |

Pre-assemble expander assemblies (1 x 10" threaded rod, 1" nuts and 1" washers) before installing ring. Run all four (4) 1" nuts to center of each threaded expansion rod. Position washers outside of nuts. Nuts and washers will later be run outward after all sections of ring have been assembled. See Fig. 14.

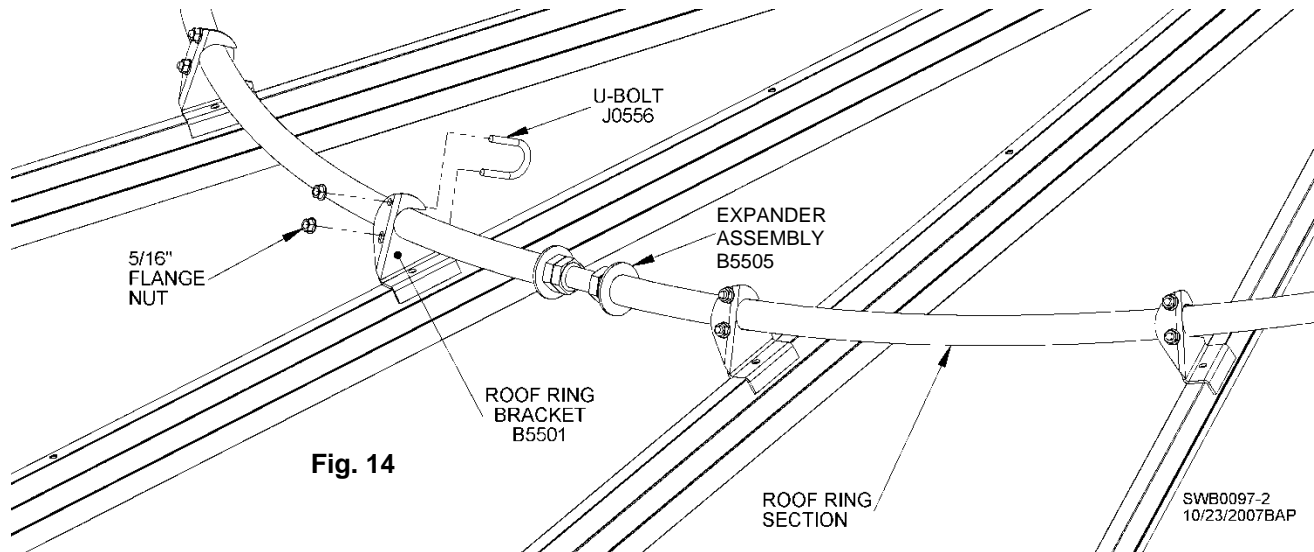
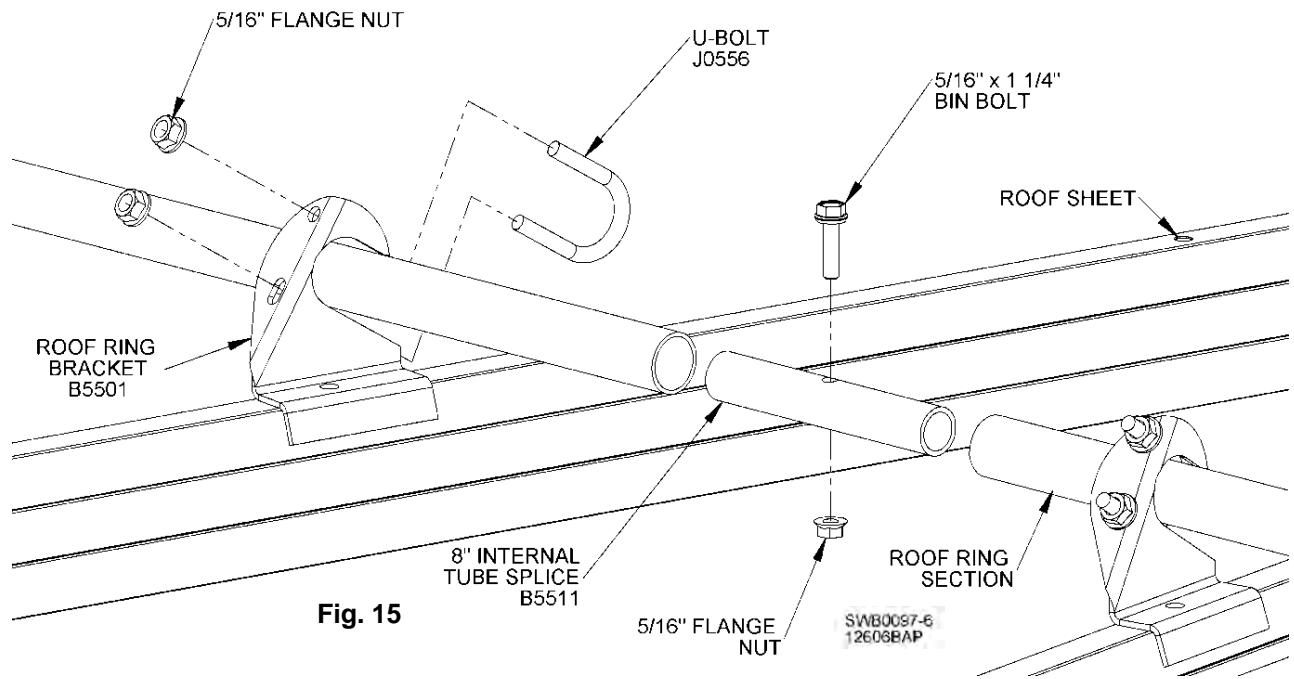
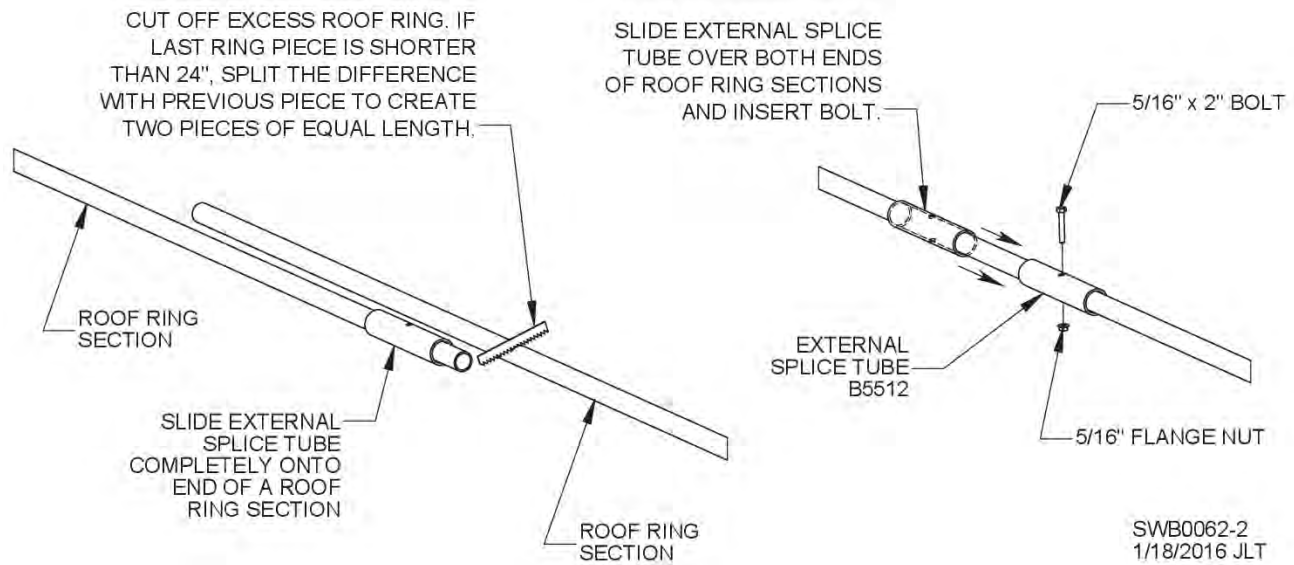

Fig. 14

Place first expander assembly near roof ladder. Center first ring section on roof ladder sheet. Evenly space remaining expanders around roof ring as ring sections are placed into bent roof ring brackets. Install internal tube splices (B5511) at all other locations except last one, where an external splice tube will be used. Fig. 15 shows 8" internal tube splice using a 5/16 x 1-1/4" bin bolt as a stopper. Fig. 16 shows 8" external splice tube (B5512) using 5/16 x 2" bolt. Place 5/16" U-bolts on all roof ring mounting brackets. See Figs. 14 and 15. Do not tighten U-bolt flange nuts until later after roof has been crowned.



External splice tube will be installed after all other splices and expanders are in place and ring sections are trimmed. If final section of roof ring will be less than 24" long, split the difference with previously assembled roof ring section and create two sections of equal length. See Fig. 16. Ensure there is a 3/8" gap between ring sections for bolt that will be inserted. It may be necessary to deburr cut edges.



Slide external splice tube (B5512) over one end of roof ring. Align ring sections and position splice over both. Insert 5/16 x 2" bolt into splice tube and lock in place with 5/16" flange nut.

Adjust expander assembly nuts until a slight crown appears in middle of roof sheets. Tighten second set of nuts (jam nuts) against expander nuts to help prevent loosening. Tighten 5/16" flange nuts on 5/16" U-bolts at all bent roof ring brackets.

NOTICE: Roof ring will fail if expander assemblies become loose due to high winds or excessive pressures. To guard against failure, be sure to follow procedures on these pages when installing ring.

2-1/2" Internal Roof Ring

Table 6 – Quantities of internal roof ring components

| Farm Bin | Bin Dia. | 2-1/2" Internal Roof Ring Pkg. | Locating Holes* | Mounting Brackets BC3106 | Internal Support Brackets B5790 | 18' 9" Tube 2-1/2" Dia. | 2-1/2" Tube Splice Assy. BC3101** |
|----------|----------|--------------------------------|-----------------|--------------------------|---------------------------------|-------------------------|-----------------------------------|
| Option | 30' | BC8301 | 5, 6 & 7 | 10 | 10 | 3 (15') | 3 |
| Option | 33' | BC8331 | 5, 6 & 7 | 11 | 11 | 4 (18') | 4 |
| Option | 36' | BC8361 | 5, 6 & 7 | 12 | 12 | 4 (21') | 4 |
| Option | 42' | BC8421 | 5, 6 & 7 | 14 | 14 | 5 (27') | 5 |
| Option | 48' | BC8481 | 5, 6 & 7 | 16 | 16 | 6 (33') | 6 |

* Location determined by counting holes from bottom edge (eave) of roof sheet.

** Two (2) formed pieces (BC3101) required at each splice assembly location.

Internal roof ring support brackets are to be attached to roof ribs at every third (3rd) roof sheet. It is recommended that brackets and 2-1/2" internal roof rings be installed after outer roof rings are attached, expanded, and U-bolts tightened. These roof ring support brackets can be attached over existing flange nuts if roof is already completely tightened. See Table 6 to determine amount of hardware used.

Fig. 17

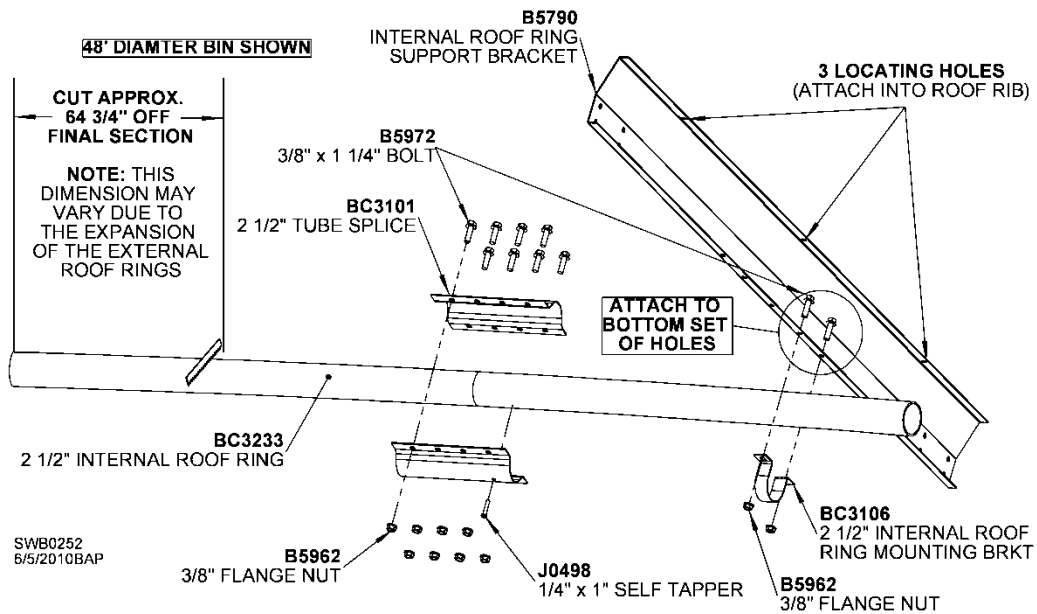

NOTE: Fig. 17 shows installation of 2-1/2" internal roof ring. Support bracket is reversible for ease of assembly. Use 2-1/2" mounting brackets to attach internal roof ring to support brackets. Use bottom set of holes with 3/8" x 1-1/4" bolts and 3/8" flange nuts.

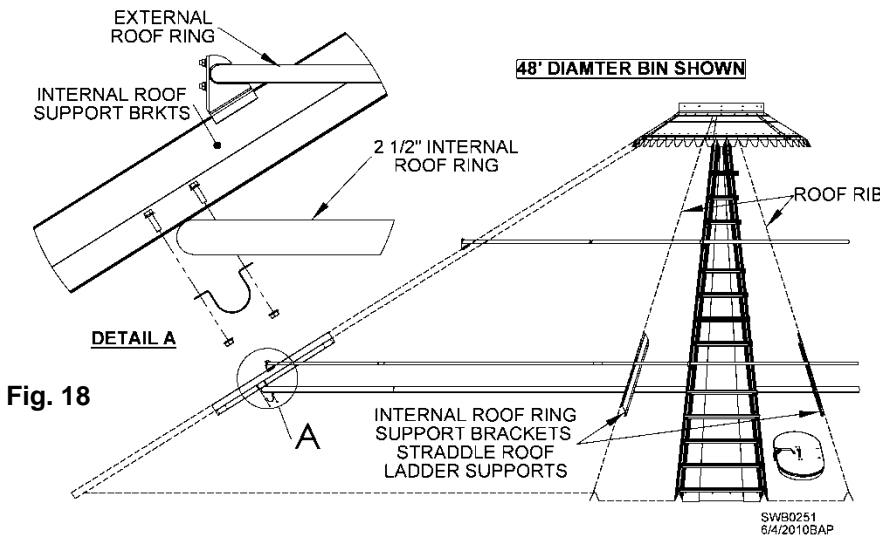

After external roof rings are expanded and U-bolts tightened, attach 2-1/2" internal roof ring sections to support brackets as shown in Fig. 18. Tube sections should be attached to one another with tube splices, 3/8" x 1-1/4" bolts and 3/8" nuts. Screw 1/4" x 1" self-drilling screws into each tube section to reduce any slack or gaps that may occur during assembly. Final section of tube needs to be cut off so final section butts up against first section without any gap between them. A minimum of about 64-3/4" should be cut off. This dimension may vary due to expansion of external roof rings.

Manhole Cover Assembly

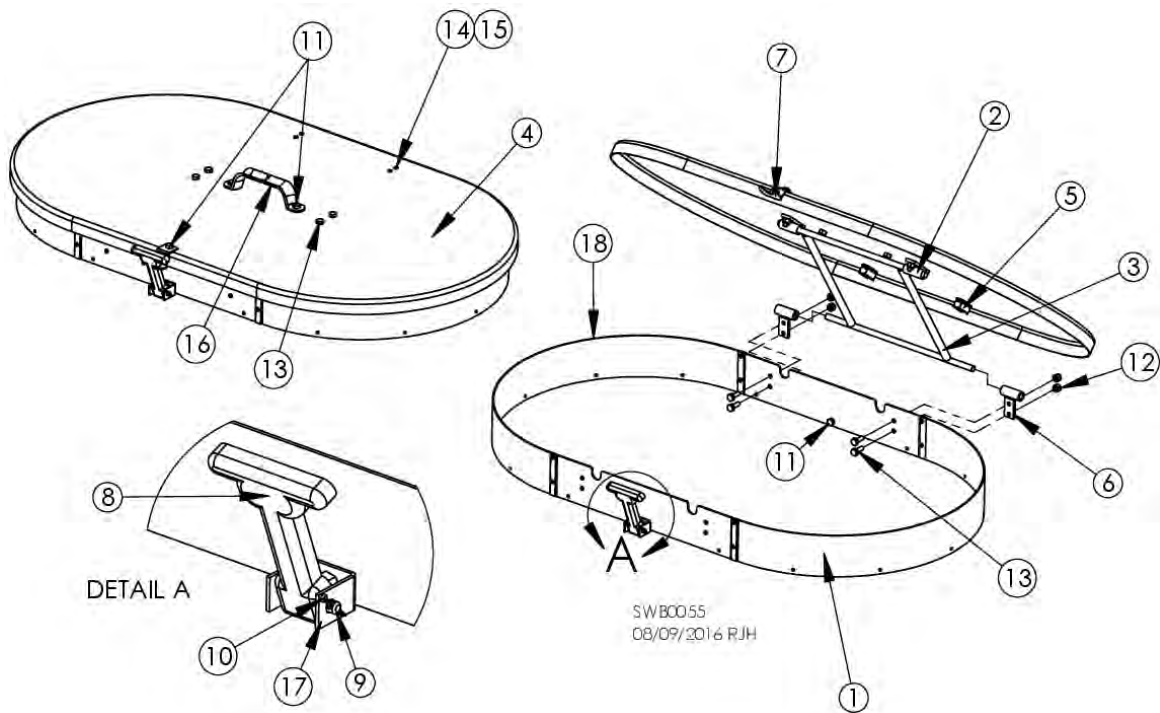

Fig. 19 & Table 7

| ITEM | COMP. # | DESCRIPTION | QTY. |
|------|---------|--------------------------|------|
| 1 | B5384 | Riser assembly | 1 |
| 2 | B5386 | Cover hinge | 2 |
| 3 | B5387 | Hinge frame | 1 |
| 4 | B5381 | Cover | 1 |
| 5 | J4446 | Lid clip | 4 |
| 6 | B5385 | Side hinge | 2 |
| 7 | B5388 | Lid bracket | 1 |
| 8 | J23073 | Rubber latch strap | 1 |
| 9 | J15443 | Picker pin, 1/4 x 1-1/2" | 1 |
| 10 | J1419 | Cotter pin, 1/16 x 3/4" | 1 |
| 11 | J0504 | Bolt, 1/4 - 20 x 1/2" | 5 |
| 12 | J0992 | Lock nut, 1/4" | 13 |
| 13 | J0505 | Bolt, 1/4 - 20 x 3/4" | 8 |
| 14 | J0455 | Screw, #6-32, 1/4" | 4 |
| 15 | J0982 | Hex nut, #6-32 | 4 |
| 16 | J3232 | Handle | 1 |
| 17 | J23074 | Anchor bracket | 1 |
| 18 | J70955 | Vinyl edge guard | 1 |

Install manhole cover by first attaching a single side hinge (Item 6) to pre-assembled manhole riser (Item 1) using 1/4 x 3/4" bolts and 1/4" nuts. Ensure side hinge is bolted to outside of riser with hinge frame cylinder toward top. See Fig. 19. Hinges should be placed opposite of sidewall ladder for ease of access into bin through manhole. Insert bolts from inside of riser as shown. **NOTE:** Slots in top of riser eliminate interference between hinge frame (Item 3) and riser as lid is closed.

Insert hinge frame with attached cover into previously assembled side hinge. Place second side hinge onto hinge frame and bolt to riser using 1/4 x 3/4" bolts and 1/4" nuts. Install vinyl edge guard around top of riser by pressing onto lip. Cut away material over slots on hinged side of riser so hinge frame can close.

Attach rubber latch strap (Item 8) into pre-assembled anchor bracket (Item 17) at base of riser and secure with picker pin (Item 9) and cotter pin (Item 10). Rubber latch strap secures lid by locking it down onto riser.

Peak Ring Cap Assembly

Fig. 20

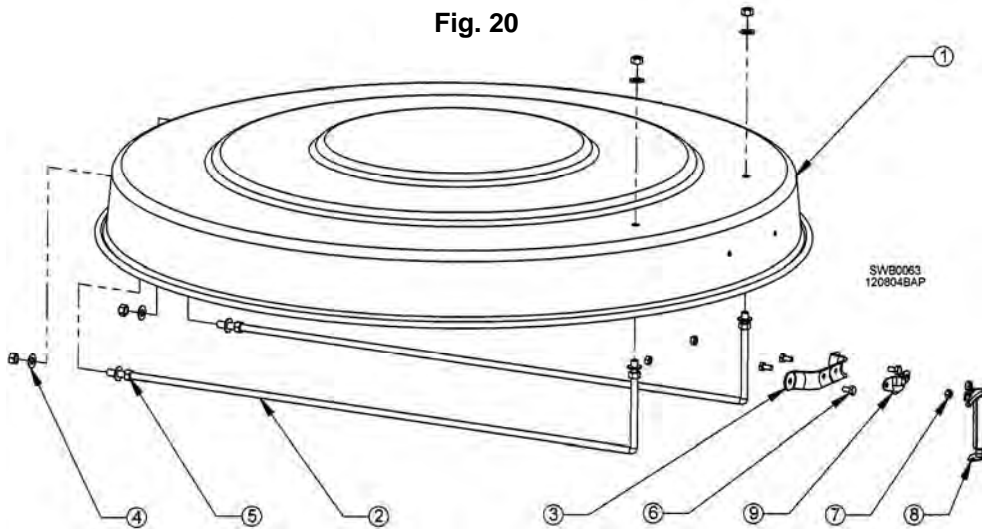

Table 8 – Peak ring cap components

| REF. # | DESCRIPTION | QTY. | COMP. # |
|--------|---------------------------|------|----------|
| 1. | Peak ring cover, w/ holes | 1 | B53612 |
| 2. | Fill cap rod | 2 | B5361-01 |
| 3* | Fill cap handle | 1 | B5361-02 |
| 4. | Flat washer, 3/8", PLT | 8 | J1117 |
| 5. | Hex nut, 3/8" - 16, PLT | 8 | J1020 |
| 6* | Bolt, 1/4 - 20 x 1/2" | 4 | J0504 |
| 7* | Hex nut, 1/4" - 20 | 4 | J0990 |
| 8. | Spring-loaded latch | 1 | J2298 |
| 9* | Latch catch | 1 | J2297 |

*Items 3, 6, 7 & 9 included in B5361 Peak Handle Assembly

Attach fill cap handle to front of fill cap with two (2) 1/4 - 20 x 1/2" bolts and 1/4" lock nuts. See Fig. 20. **NOTE:** Latch catch is pre-assembled to handle. Make certain open end is facing skyward.

Thread a 3/8" hex nut onto each end of each peak ring cap rod (also known as fill cap rod) and slide a 3/8" flat washer over each rod. Slide long ends of rods through holes in back of cap and short ends through top of cap as shown in Fig. 20. Slide a second 3/8" flat washer onto each end of rod, followed by a second 3/8" hex nut. Adjust so hex nuts on top of cap are flush with end of slide rods and tighten inside nuts. Close cap and adjust for centering. Hang spring-loaded latch from latch catch. Extend spring-loaded latch until it comes into contact with apron. Mark and field-drill latch location. Attach spring-loaded latch to apron with 1/4 - 20 x 1/2" bolts and 1/4" hex nuts.

Attach peak ring cap bracket to roof rib as shown in Fig. 21, making sure to use hole specific to bin diameter.

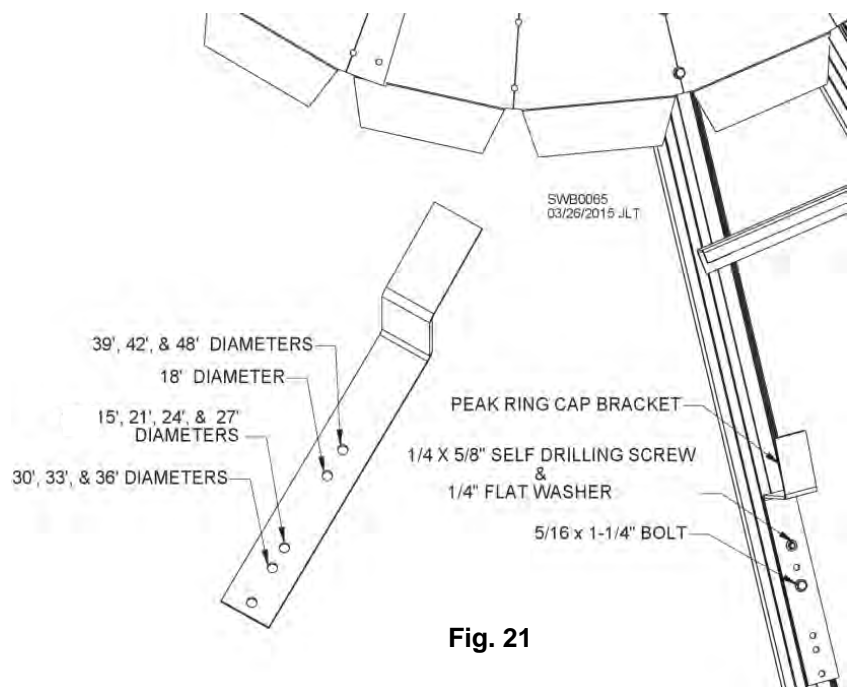

Fig. 21

NOTE: If spiral stairs are to be installed, use a grinder or tin snips to trim or round off corners of roof panels to prevent accidental snagging.

Poly Roof Vent Assembly

Follow instructions on this and next page to install Poly Roof Vent. If using optional snow guard, attach as shown in Fig. 24 before screen is attached to vent. See Fig. 25 and related instructions for attaching braces to vents on bins in ASCE 7-10 Code, 136 mph or higher wind zone.

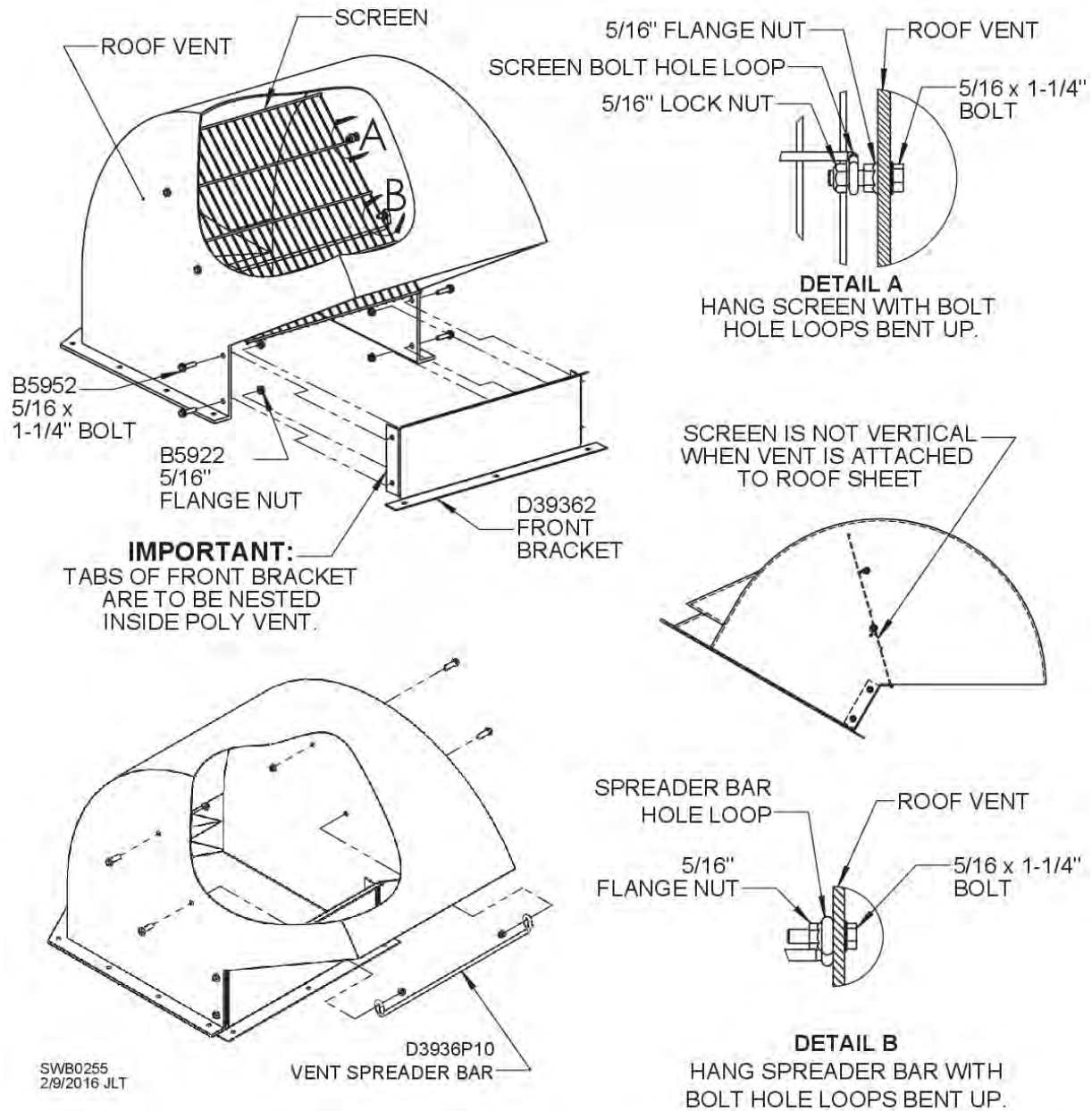

Fig. 22

Insert 5/16 x 1-1/4" bolts into pivoting screen holes from outside in as shown above. Tighten to poly vent with 5/16" flange nuts. Work the pivoting screen bolt hole loops over the 5/16 x 1-1/4" bolts with loops bent up as shown in Detail A. Screen should be attached so it will be at a slight angle when vent is attached to roof. Screen should not be vertical. Fasten 5/16" lock nuts to ends of 5/16" bolts as shown above to ensure screen stays in place and can pivot freely on bolts. Attach vent spreader bar as shown above using 5/16" bolt and flange nut. Ensure loops are bent upward.

Tabs of front bracket should be nested inside of poly vent. Apply butyl caulk to front edges of roof vent to ensure a watertight seal when front bracket is fastened.

Attach front bracket to poly roof vent using 5/16 x 1-1/4" bolts and 5/16" flange nuts. Tighten all hardware.

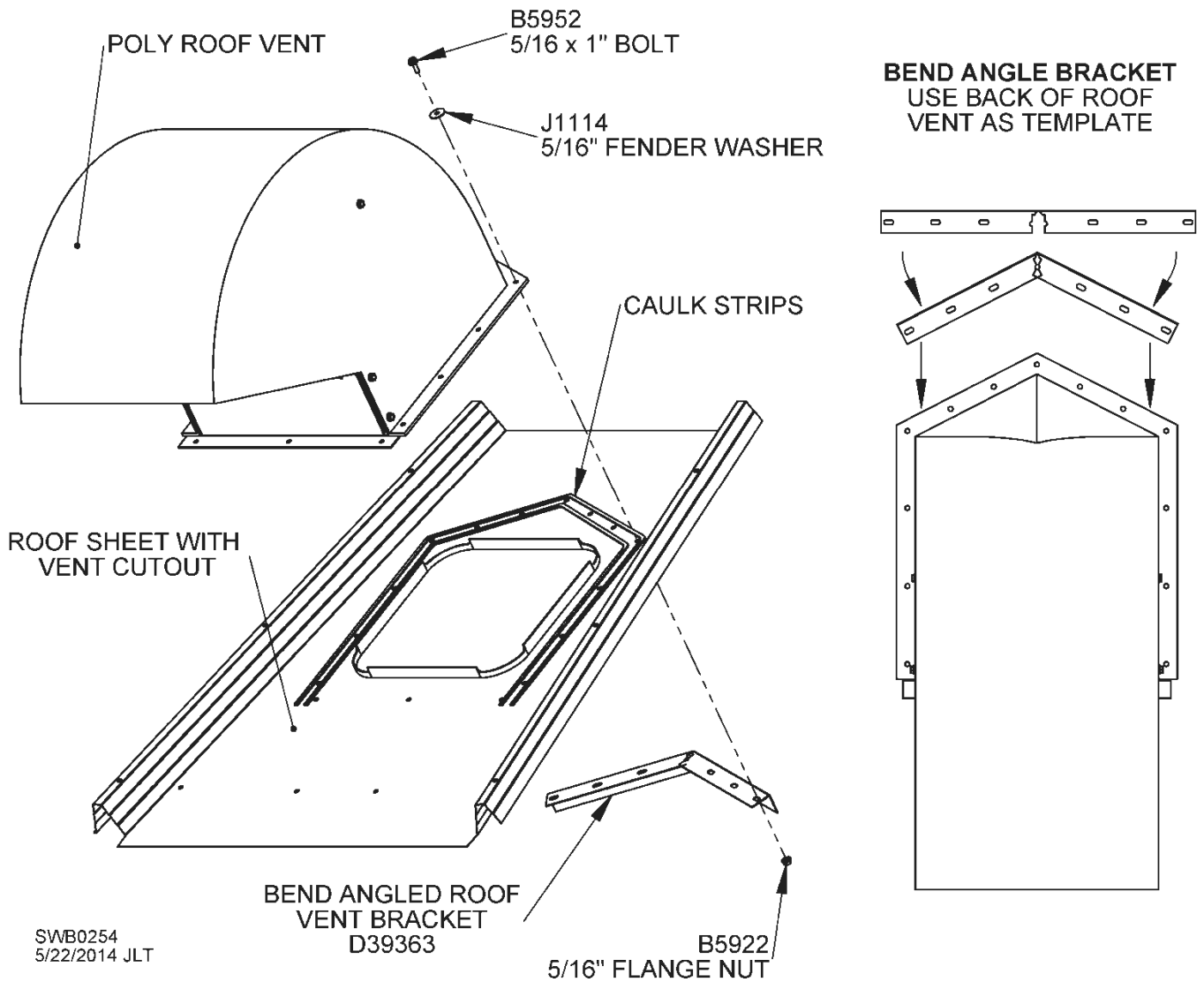

Fig. 23

Apply two strips of butyl caulk around cutout, one on each side of mounting holes, as shown in Fig. 23. Additional butyl caulk is provided to apply a double stack on top side of roof vent cutout. Apply butyl caulk close to mounting holes, leaving a 1" gap around outside strip.

Field-bend angle bracket using back of vent as a template.

Attach roof vent and angle bracket to roof sheet using 5/16 x 1-1/4" bolts, 5/16" fender washers and 5/16" flange nuts as shown in Fig. 23. Use 5/16" fender washers on top side of poly flange. **NOTE:** To prevent damage to poly roof vent flanges, secure vent to roof by tightening nuts on underside of roof sheet instead of tightening bolts on top side. To prevent puckering of vent flanges, do not over-tighten nuts.

Check sealant along top side of roof vent base for any gaps or pockets. Apply a bead of tube caulk (not provided) along top side of base to ensure a watertight seal.

IMPORTANT: Check caulk along top side of base yearly and re-apply as needed to prevent leakage.

Attaching Optional Snow Guard & Vent Braces

Attach optional snow guard to vent screen as shown in Fig. 24 using 5/16" hardware.

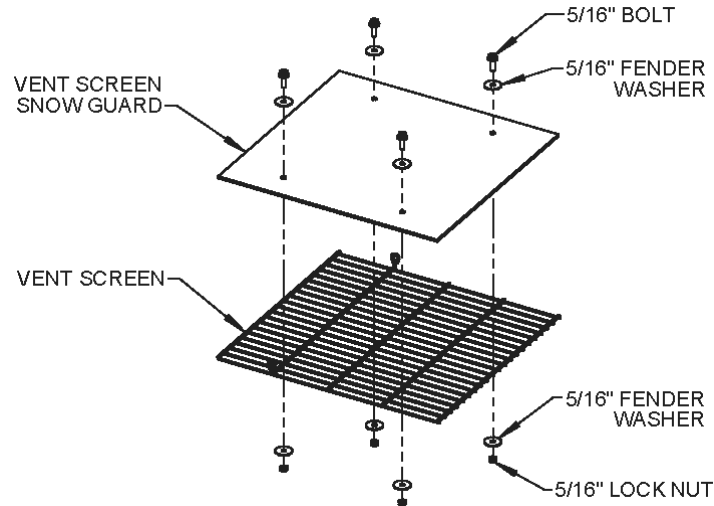

Fig. 24

Braces for Vents in 136 mph or Higher Wind Zones

Add braces to poly roof vents to provide greater stability on bins in ASCE 7-10 Code, 136 mph or higher wind zone.

Adjust braces so that holes on flat ends will attach to sides of roof vent and to top of roof sheet ribs as shown in Fig. 25. Position braces so they are spaced out as much as possible.

After ensuring vent brace alignment, drill holes in sides of roof vent and top of roof ribs.

Use 5/16" hardware to attach D3936P7 braces to all four (4) corners of roof vent.

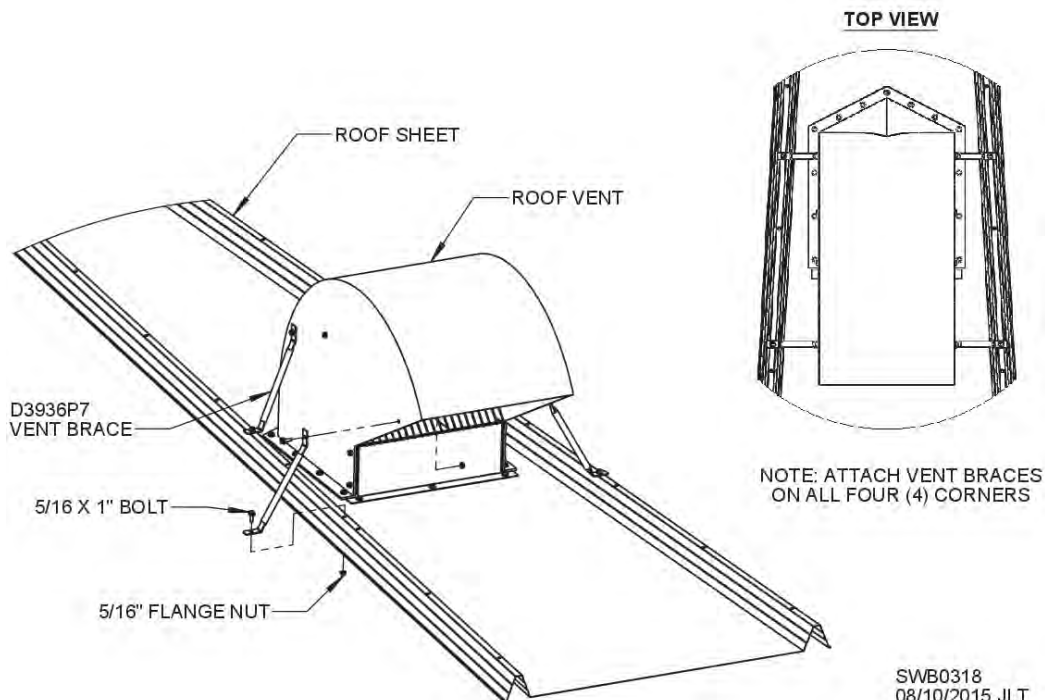

Fig. 25

SWB0318
08/10/2015 JLT

Tapered Poly Roof Vent Assembly

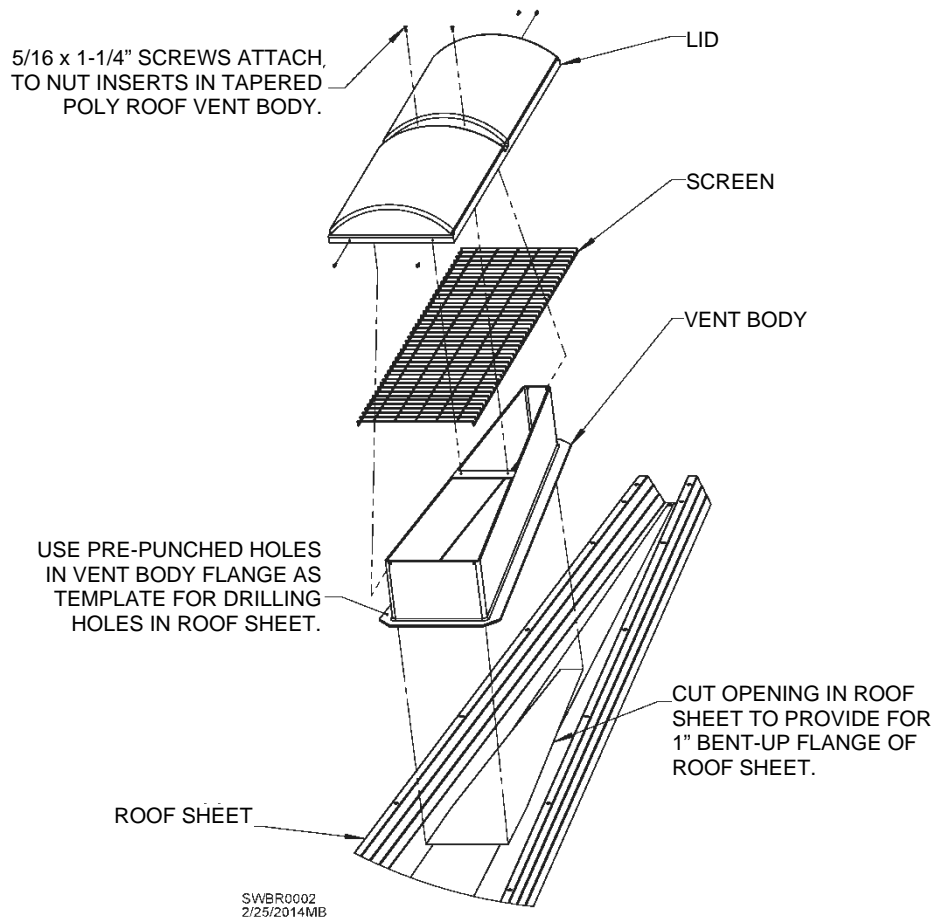

Fig. 26

Position pre-assembled vent close to peak of bin, leaving enough room to attach vent to flat area of roof sheet and allow for drainage around vent. Remove lid and screen by unscrewing five (5) 5/16 x 1-1/4" bolts from nut inserts in body of vent. Use inside of vent wall as a guide for marking roof sheet cutout opening. Draw lines for cutout 1" inside of vent sides. Set vent body aside. Cut vent hole in roof sheet, bending edges upward to create a flange that will help prevent water from leaking in. Position vent body over cutout. Use pre-punched holes in vent flanges as templates for drilling attachment holes in roof sheet. Set vent body aside.

Apply two strips of butyl caulk around cutout, with one strip on each side of mounting holes.

Attach body of vent to roof using 5/16 x 1-1/4" bolts, 5/16" fender washers and 5/16" flange nuts.

NOTE: To prevent damage to poly roof vent flanges, secure vent to roof by tightening nuts on underside of roof sheet instead of tightening bolts on outside.

Check sealant along top end and sides of vent body for any gaps or pockets. Apply a bead of tube caulk (not provided) along top end and sides of body to ensure a watertight seal.

Re-attach lid and screen to body of vent using hardware previously removed.

IMPORTANT: Check caulk around vent yearly and re-apply as needed to prevent leakage.

Temperature Cable Support Packages

There are two types of support package – roof rib support package and center support package. Depending on bin diameter, a Sukup bin requires up to five (5) rafter support packages and one (1) center support package.

1. Roof Rib Support Package:

Consists of two (2) roof rib supports, one (1) hanger bar, two (2) support brackets, one (1) shackle, eight (8) 5/16" bolts and eight (8) flange nuts.

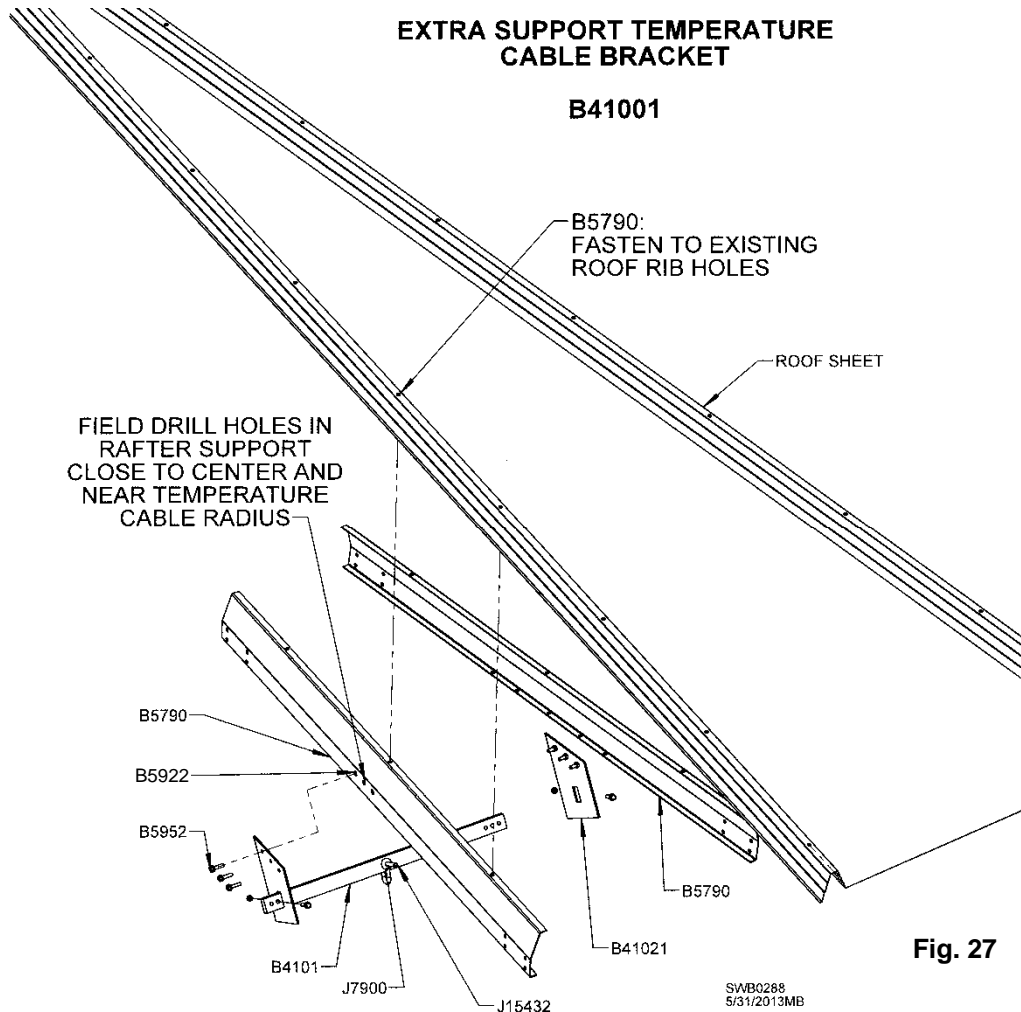

Installation requires field-drilling roof rib supports at temp cable location to attach support brackets. Determine location of roof ring. See Table 9 for temperature cable hanging locations. Attach roof rib supports into roof ribs as shown in Fig. 27 using existing holes. Center of roof rib support should be located close to temperature cable radius. Drill three (3) holes into side of roof rib support, using support brackets as drill guide. Attach each support bracket to roof rib support using six (6) 5/16 x 1-1/4" bin bolts and 5/16" flange nuts.

Place hanger bar in slots of support brackets and put a bolt and nut on each end of bar. There are three (3) holes on each end of bar to accommodate different size bins. Place bolt in closest hole to bracket, making sure bar is centered between brackets. A shackle is provided to hang temperature cable from bar. After placing thimble in shackle, attach shackle to bar at center hole.

- Make sure rafter packages are hung directly beneath correct roof ring.
- Do not attach more temperature support packages than recommended.
- Follow instructions provided by temperature cable provider.

2. Center Support Package:

Consists of one (1) hanger bar, two (2) support brackets, one (1) shackle, six (6) 5/16" bolts and six (6) flange nuts. See Fig. 28.

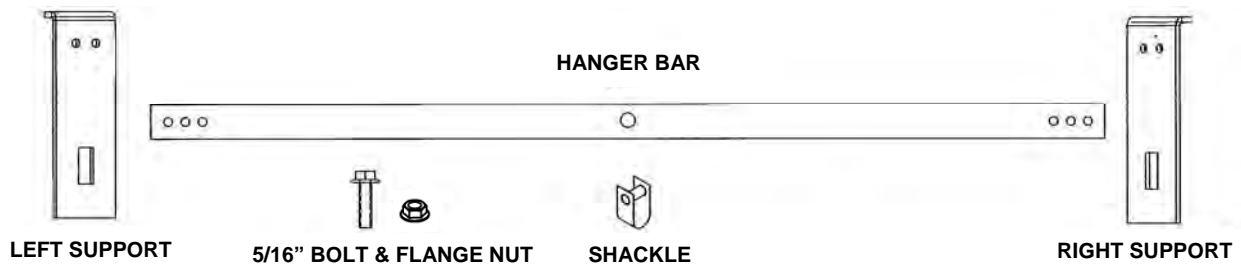
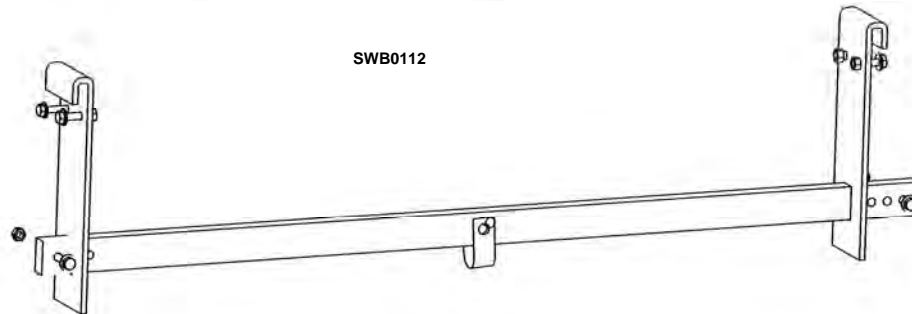

Fig. 28



Installation requires field-drilling of roof ribs (rafters). Determine centerline of peak ring. See Table 9 for temperature cable hanging locations. Drill two (2) holes on each side of peak ring. Attach each support bracket to peak ring while making sure bolt heads are outside and nuts are inside with support brackets. Place bar between brackets. Place bolt and nut on each end of bar. See Fig. 28. There are three (3) holes on each end of bar to accommodate different size bins. Place bolt in closest hole to bracket, making sure bar is centered between brackets. Make sure bar goes full diameter of peak ring (right at center of peak ring circle). A shackle is provided to hang temperature cable from bar. After placing thimble in shackle, attach shackle to bar at center hole.

- Do not attach more temperature cable support packages than recommended.
- Follow instructions provided by temperature cable provider.

| Bin Diameter (ft.) | Number of Sidewall Rings | Center Support Package | Roof Rib Support Package | Location |
|--------------------|--------------------------|------------------------|--------------------------|---------------------|
| 15 | 4-10 | 1 | -- | Center |
| 18 | 4-10 | 1 | -- | Center |
| 21 | 4-10 | 1 | -- | Center |
| 24 | 4-10 | -- | 3 | @ 4' Radius |
| 27 | 4-10 | -- | 3 | @ 5' Radius |
| 30 | 4-10 | -- | 3 | @ 6' Radius |
| 33 | 4-10 | -- | 3 | @ 8' Radius |
| 36 | 4-10 | -- | 3 | @ 8' Radius |
| 39 | 4-10 | 1 | 3 | 1 @ Ctr., 3 @ 10' R |
| 39 | 11-24 | | | NA |
| 42 | 4-10 | 1 | 4 | 1 @ Ctr., 4 @ 11' R |
| 42 | 11-24 | | | NA |
| 48 | 4-10 | 1 | 5 | 1 @ Ctr., 5 @ 16' R |
| 48 | 11-24 | | | NA |

Table 9 – Temperature cable support placement on Sukup 5K roof

Restraint Anchor Installation

Install restraint anchor eyebolt 2" below horizontal line of eave clip bolt holes on inside wall of bin. See Fig. 29. Field-drill 1/2" hole below manhole roof sheet rib. Insert eyebolt as shown, making sure ring is perpendicular to ground, and secure with 1/2" washer and 1/2" flange nut.

As shown in Fig. 29, place decal **L0907** on inside of bin just under eyebolt location.

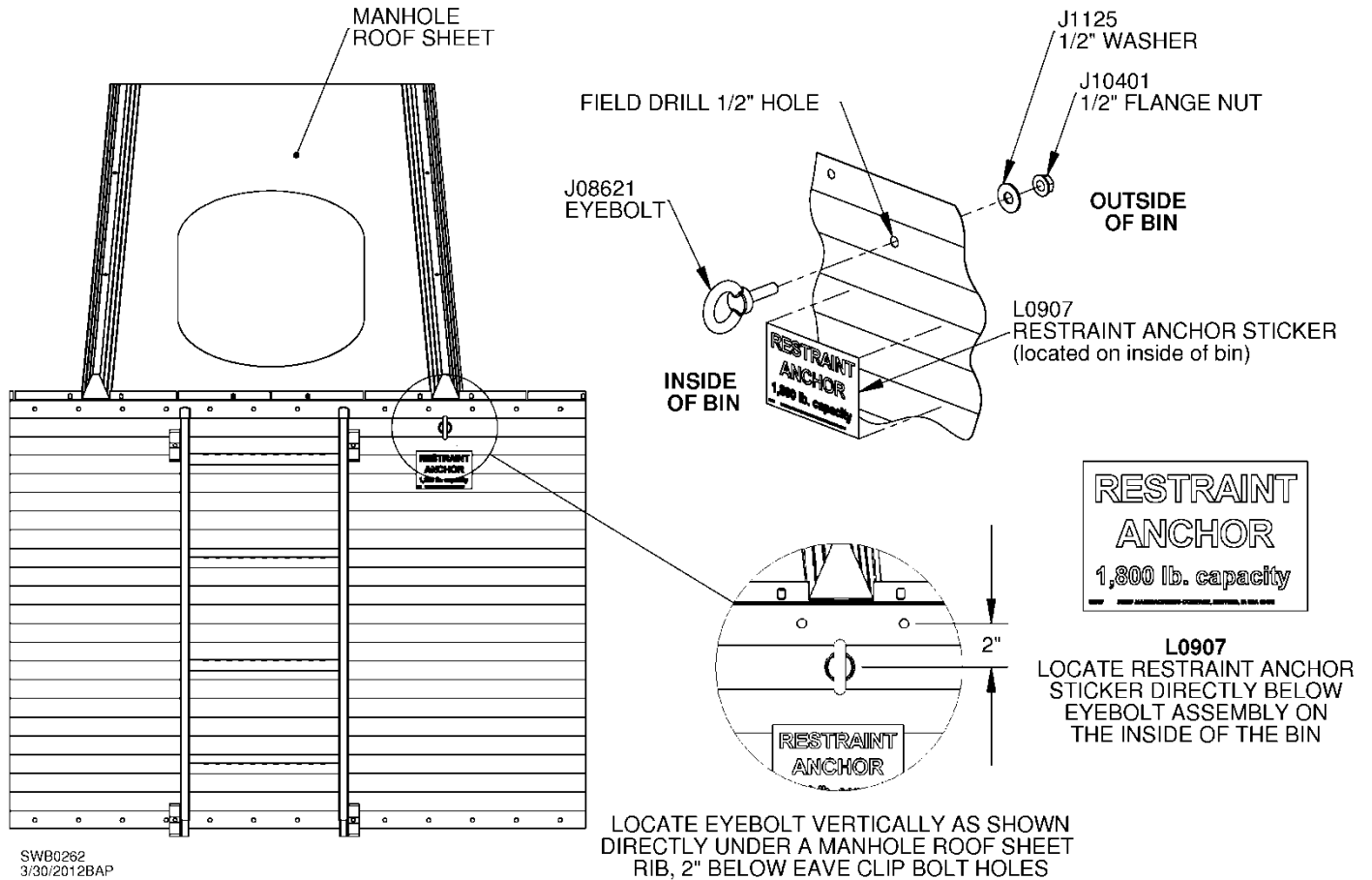
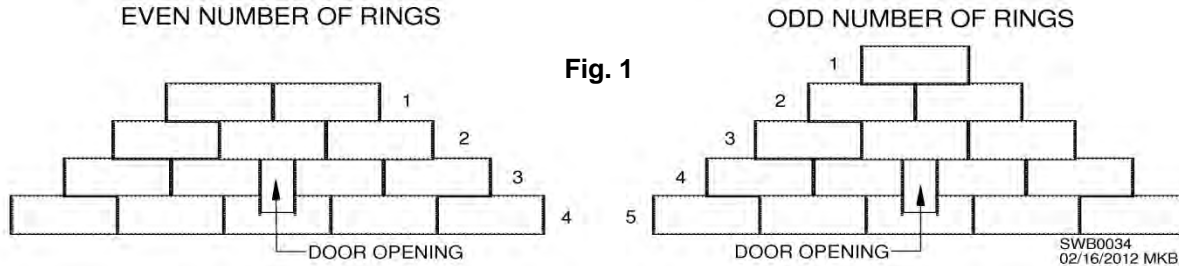

Fig. 29

Farm Stiffened Sidewall Construction

Before starting assembly of grain bin, confirm locations of components. See Foundation Section for typical accessory layout diagram. Locations for door, unload system and fan or fan/heater transition should have been determined before foundation was poured.

NOTE: On a bin with an even number of rings (4, 6, 8, etc.), door will be straight below a vertical seam in first (top) ring. On a bin with an odd number of rings (5, 7, 9, etc.), door will be straight below center of sidewall sheet in first (top) ring. See Fig. 1.



IMPORTANT: If bin door and unload system will be in same sidewall sheet, ensure that sheet is reinforced around cutout for unload system. See Figs. 13 and 14 for cutout reinforcement instructions.

IMPORTANT: Sukup grain bins require snug fit connections. A snug fit is when steel sheets are fully drawn together, allowing for a thin layer of caulk and compressing rubber washers to seal bolt holes. Snug fit is usually attained with a few impacts of an impact wrench. **NOTE:** All 3/8" bolts use flange nuts. Torque to 25-35 ft.-lbs.

IMPORTANT: At no time should any bolts be substituted for those supplied by Sukup Manufacturing Co.

Locate first (top) set of sidewall sheets. Typically these will be lightest gauge of panels. **NOTE:** Larger gauge number means thinner material (For example, 20ga is thinner than 12ga). Refer to color chart that comes with sidewall sheet bundles for exact gauge layout. Use sidewall gauge table at right to identify sidewall sheets by color (painted at corner of sheet). For ease in construction, keep painted edges of panels at same corner for entire ring of bin.

| SIDEWALL GAUGE | COLOR | STIFFENER GAUGE |
|----------------|--------|-----------------|
| 20 | RED | |
| 18 | GRAY | 18 |
| 17 | BLUE | 17 |
| 15 | WHITE | |
| 14 | PINK | 14 |
| 13 | YELLOW | 6 |
| 12 | BLACK | 12 |
| 11 | PURPLE | |
| 10 | GREEN | 10 |
| 9 | BROWN | |
| 8 | ORANGE | 8 |

ATTENTION: Bin logo panel goes in first (top) ring. Determine suitable location and incorporate into sidewall ring.

IMPORTANT: All sidewall panels are reversible; there is no specific top or bottom. Two exceptions are the first (top) panel if it has been pre-punched for Fastir Stirring Machine track, and last (bottom) panel. Bottom panel may be pre-punched for plenum flashing. Ensure correct location of track and/or plenum flashing holes. For stirring machine track, extra row of bolt holes will be nearest to top edge of panel. See table below for correct location of plenum flashing holes.

| HOLE | BOLT-ON BASE ANGLE | | |
|------------|-----------------------------|--------------------|-----------------------|
| | FLASHING HOLE FROM CONCRETE | SUPPORT | FLASHING |
| Standard | 15" | 12-1/2" 13-1/4" | High-back Standard |
| "F" Option | 17" | 15-7/8" | Standard |
| "G" Option | 19" | 15-7/8" 17" | High-back |

Place sidewall panels around perimeter of foundation. Proceed clockwise. After placing first sidewall panel, place next sidewall panel so it overlaps inside of previous sidewall panel. See Fig. 2.

Working clockwise from inside of bin, wipe off vertical panel edges and apply caulk as shown in Fig. 3. Drawing also shows where caulk will be placed later when attaching panels for second ring.

NOTE: Fig. 3 shows assembly proceeding clockwise from inside of bin. If working counterclockwise, ensure proper placement of caulk.

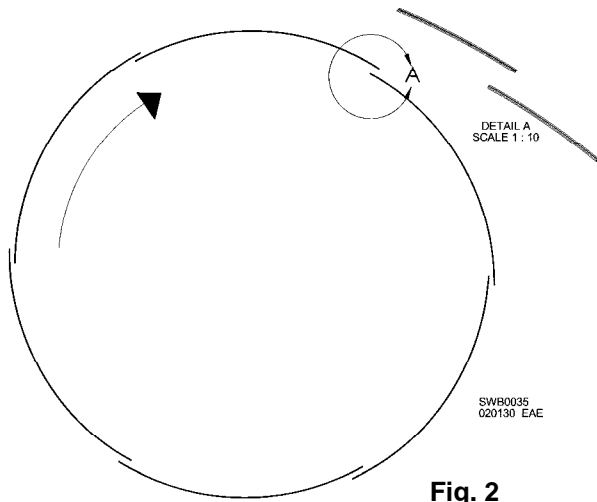
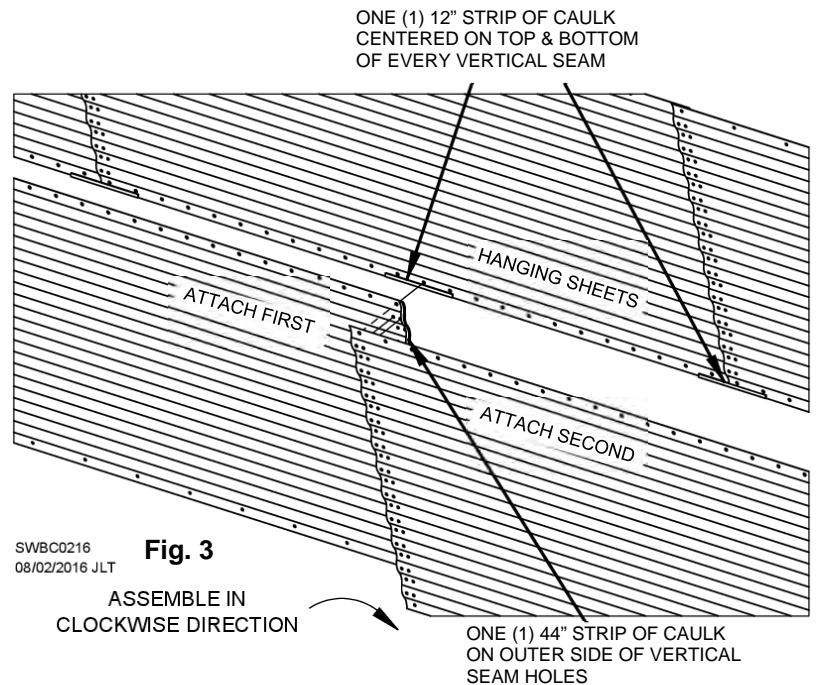

Fig. 2



SWBC0216
08/02/2016 JLT

Fig. 3

ASSEMBLE IN
CLOCKWISE DIRECTION

Bolt panels together at vertical seam using 3/8 x 1" bolts. Leave very top and bottom seam bolts out, using tapered punches to ensure alignment. Install bolts with head and seal washer on outside and nut on inside. **IMPORTANT:** Do not tighten bolts until ring is completely assembled. Attach 42-7/8" tapered top stiffeners and eave clips. See Fig. 6 and roof section of manual.

NOTICE: To prevent washer damage and moisture leakage, hold **BOLT** stationary while tightening. Spin **NUT** only! See Fig. 4.

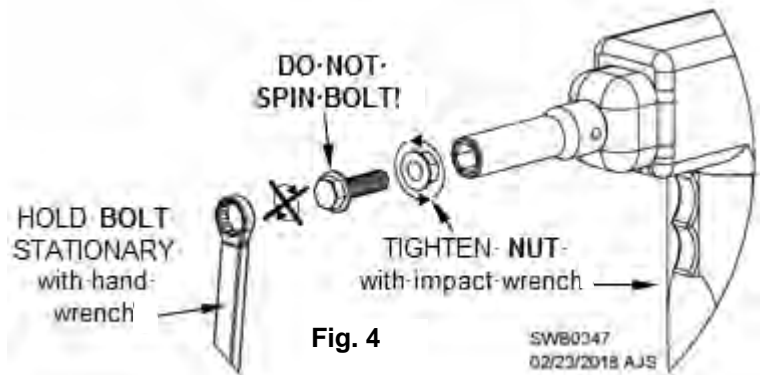

Fig. 4

Jack Bolt Usage

Quantity of 3/8 x 2" jack bolts supplied depends on diameter and height of bin. Standard usage is four bolts per jack and one jack per two sidewall sheets. **NOTE:** Generally, more jacks will be used as more rings are added.

Jack bolts are supplied without reducing quantity of standard 3/8 x 1" bolts.

Attach lift brackets for jacks as recommended by jack manufacturer's specifications.

After first (top) ring is complete, assemble roof as outlined in 15' - 48' 5K Roof Assembly section.

When roof assembly is complete, tighten all roof and sidewall bolts. See Ladders, Safety Cages and Platforms section for directions on attaching brackets for inside and outside ladders and/or safety cages and platforms. Install eave safety rails if so equipped. Tighten sidewall bolts after each ring is assembled.

Prepare next ring of panels by wiping clean and applying caulk as shown in Fig. 3. Ensure caulk for horizontal seams is between bottom bolt holes and edge of panel, and that caulk for vertical seams is at edge of panel as shown in Fig. 3.

Using appropriately rated erection jacks, raise bin until bottom of first (top) ring is slightly higher than top of next sidewall sheet.



WARNING: Never exceed jack manufacturer's stated capacities. Doing so could result in collapse causing death or serious injury.

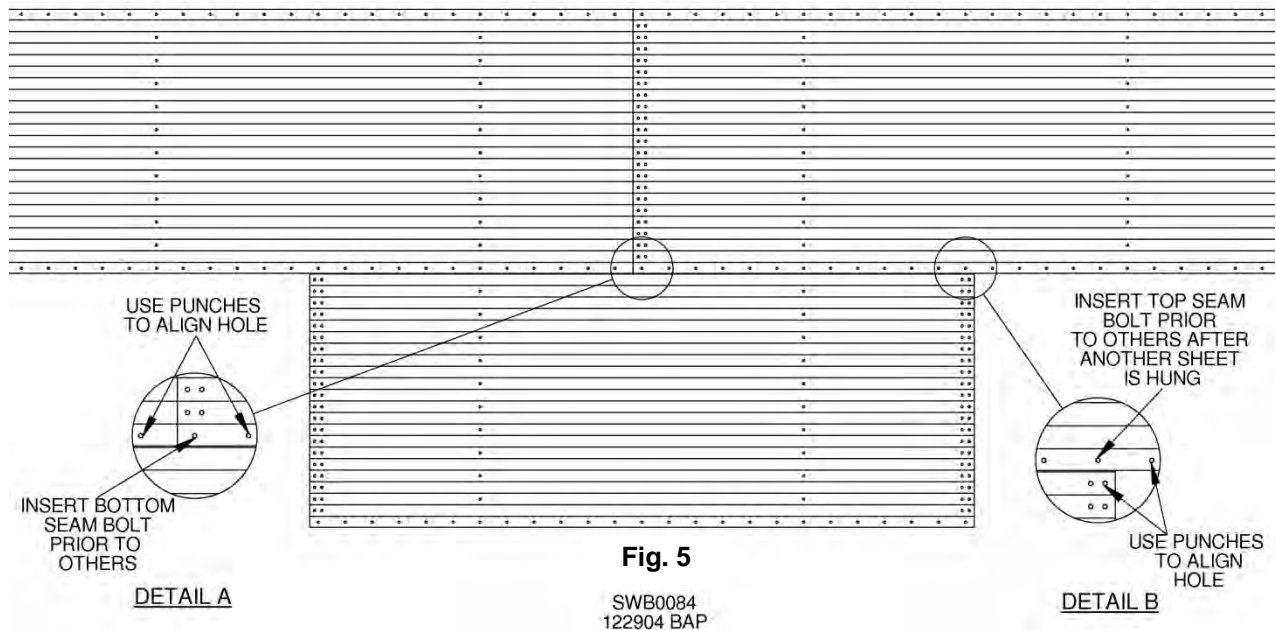

Attach a second-ring sidewall panel to inside of upper panels as shown in Fig. 5, inserting bolts in all but first and last holes in horizontal seam.

NOTE: Bolts that connect sidewall sheets must be inserted correctly to ensure precise erection of bin. Use tapered punches to properly align bolt holes. Do not leave top and bottom bolt holes of vertical seams for last. Each sidewall sheet – and entire bin -- will fit together better if bolts are inserted in proper sequence. See Fig. 5 Details A and B. Drilling or reaming out bolt holes when sheets are not properly aligned is not recommended unless otherwise specified.

Continue installing second-ring panels until ring is complete. Bolts may be tightened at this time.

IMPORTANT: After each ring has been added and bin jacks are lowered, jack bolts should be removed and replaced with bin bolts of appropriate length.

For assembly instructions for 44" and 66" sidewall doors, see Farm Duty Doors Section.

All Sukup Farm-Stiffened Bins require two (2) stiffeners per sidewall panel. All stiffeners are to be installed on exterior of bin. **NOTE:** Stiffeners will change in gauge (thickness) depending upon location. Be sure to consult Stiffened Bin Sidewall and Stiffener Gauge and Color Code Chart to ensure proper location of stiffener sections.

Start with proper gauge stiffener's top hole aligned with top hole of sidewall sheet. See Fig. 6. Proper vertical alignment of stiffener is important. Take note of where slotted bolt hole in stiffener and sidewall bolt holes in each horizontal seam intersect. Proper vertical alignment of stiffener requires slotted hole to be centered over sidewall horizontal seam bolt hole. See Fig. 6.

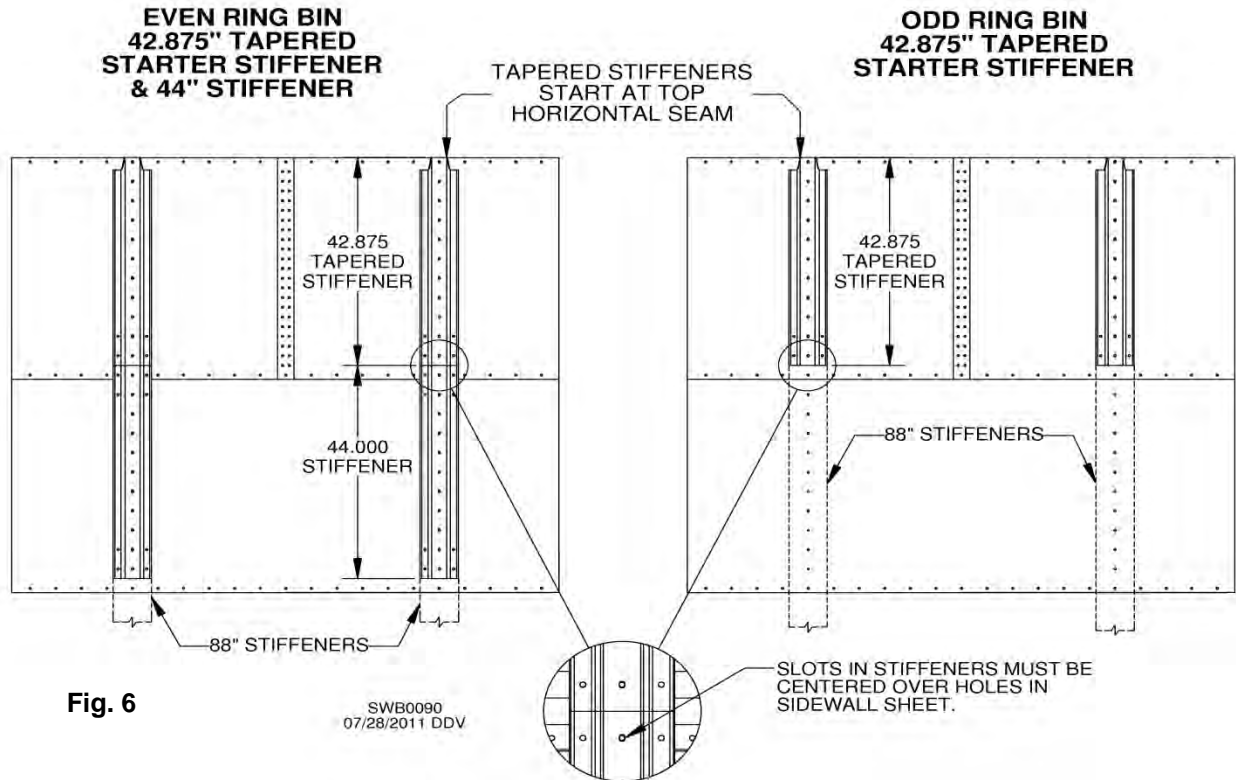

Fig. 6

All Sukup Farm-Stiffened Bins start with tapered-top stiffener 42-7/8" long. On bins with odd number of rings, continue downward with 88" stiffeners. On bins with even number of rings, continue downward with a 44" stiffener and then with 88" stiffeners. **NOTE:** Stiffener must be positioned correctly. Use tapered punch to ensure proper alignment. Do not allow stiffener to sag or it will result in assembly difficulties.

Fasten stiffener to sidewall using 3/8 x 1" bolts and 3/8" flange nuts. To prevent moisture from entering bin through stiffeners, insert bolts from inside of bin.

Leave two bottom bolts out of stiffener. Likewise, leave out top two bolts on next stiffener. Holes will be used after attachment of splice plates. Continue attaching stiffeners until first tier of stiffeners is complete.

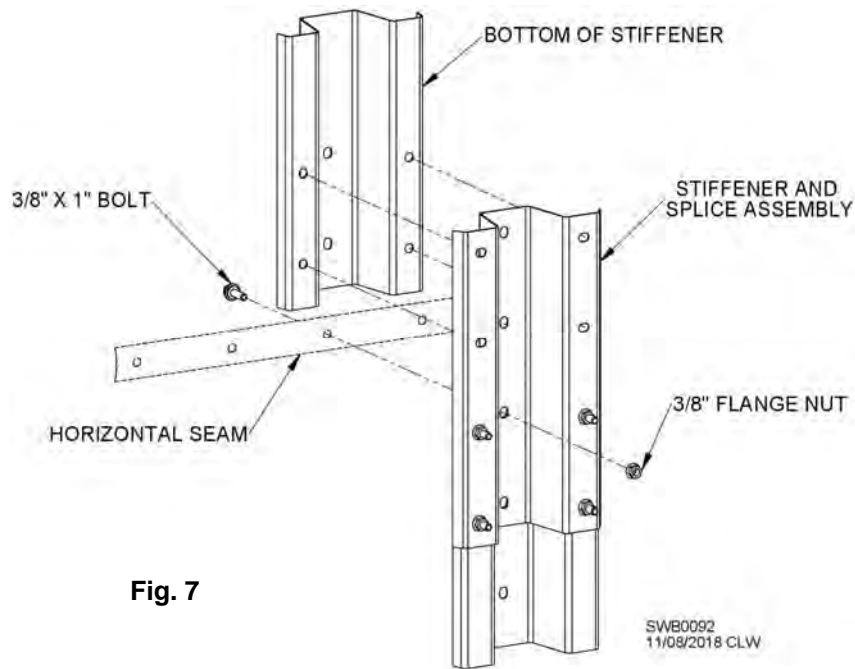

Fig. 7

Continue installing sidewall panels until enough rings are in place for installation of next tier of stiffeners. After installing stiffeners, install splices as shown in Figs. 7 and 8. **NOTE:** Stiffener splices will straddle horizontal sidewall seams. When attaching stiffeners, ensure that gap between upper and lower stiffener is no more than 1/16".

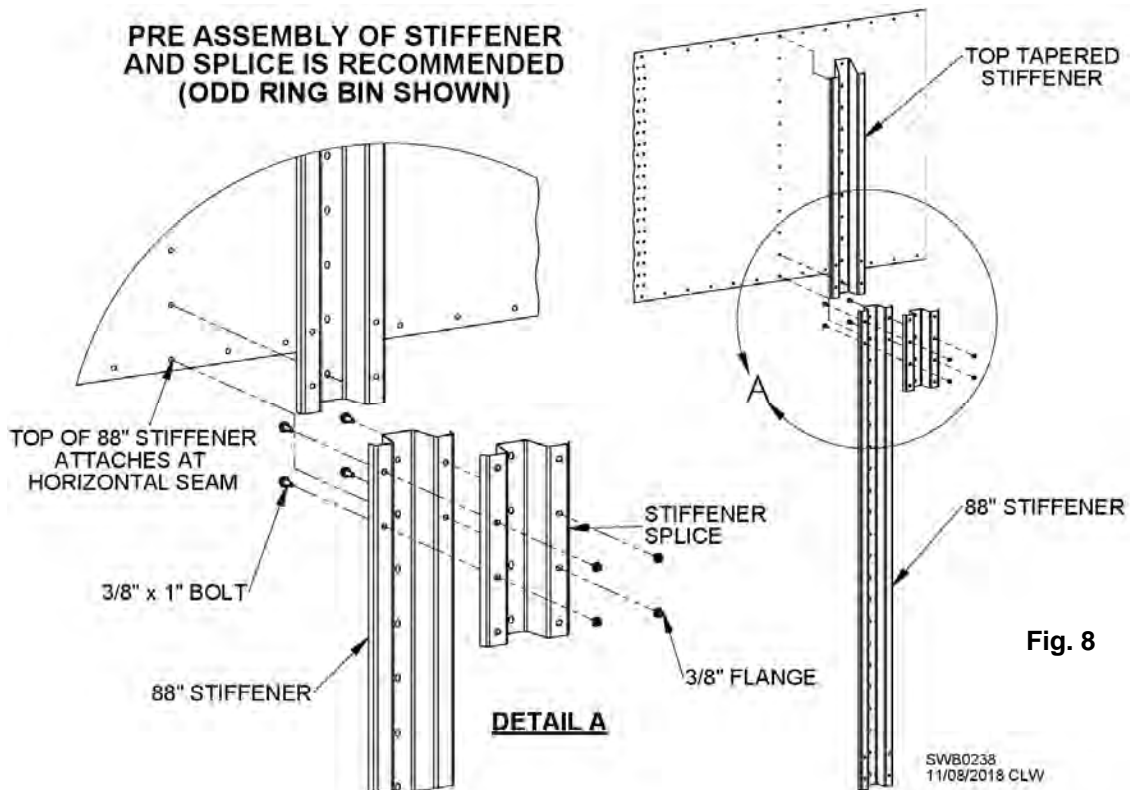

Fig. 8

Attach stiffener splice using 3/8 x 1" bolts and 3/8" flange nuts. **NOTE:** When next stiffener down increases in gauge thickness, stiffener splice plate must also increase in thickness. Always use same gauge splice plate as heaviest stiffener being spliced. Place eight (8) bolts in splice flanges and four (4) bolts through stiffener, neoprene washer and bin sidewall. See Fig. 8.

Continue assembly of bin, including stiffeners, in proper sequence as outlined in Stiffened Bin Sidewall and Stiffener Gauge and Color Code Chart.

NOTE: Use 3/8 x 1" bolts on horizontal seams where 13ga and 12ga panels overlap, and on sidewall panels connected to door frame. This will include short sheets on either side of 44" and 66" doors, as well as 66" door cutout sheet. See Fig. 9.

For bin door assembly and installation, refer to Door Assembly Section.

NOTE: If erecting a hopper bin that doesn't have a door, disregard Fig. 9 and door references in preceding two paragraphs. Refer to hopper section of Hopper Bin manual for instructions on how to attach hopper bottom to bin.

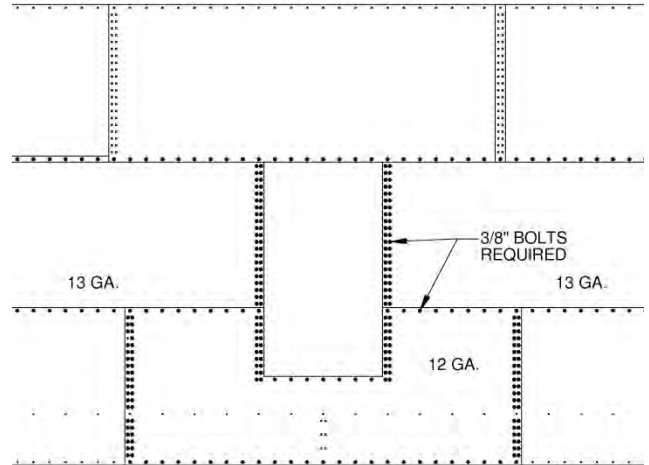

Fig. 9

SWB0113
02162012 MKB

With bottom ring completely assembled, position bolt-on base angle sections. See table to confirm components and quantity needed. **NOTE:** Ensure base angle pieces overlap by one bolt hole. Apply caulk as shown in Fig. 10. Bolt base angle to inside of sidewall panel. Use 3/8 x 1" bolts and 3/8" flange nuts.

If foundation sealant is used, apply to bottom of base angle as shown in Fig. 11 before lowering bin onto concrete or hopper bottom. Do not leave gaps between lengths of sealant. One of two types of sealant will be used, depending on diameter of bin. For bins 15' to 33' dia., use 3/8" x 3/4" sealant (J23313). For bins 36' dia. or larger, use 1/2" x 1-1/2" sealant (J23312).

| BIN DIA. | COMP. # | DESCRIPTION | QTY. |
|----------|---------|----------------------|------|
| 15' | B5721L | Base angle, 15' Dia. | 5 |
| 18' | B5723L | Base angle, 18' Dia. | 6 |
| 21' | B5725L | Base angle, 21' Dia. | 7 |
| 24' | B5724L | Base angle, 24' Dia. | 8 |
| 27' | B5728L | Base angle, 27' Dia. | 9 |
| 30' | B5726L | Base angle, 30' Dia. | 10 |
| 33' | B5731L | Base angle, 33' Dia. | 11 |
| 36' | B5729L | Base angle, 36' Dia. | 12 |
| 39' | B5740L | Base angle, 39' Dia. | 13 |
| 42' | B5727L | Base angle, 42' Dia. | 14 |
| 48' | B5730L | Base angle, 48' Dia. | 16 |

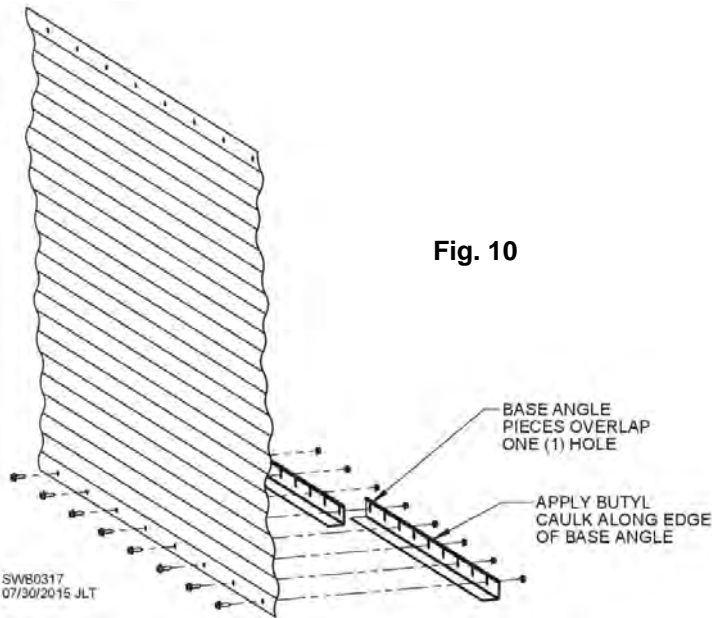

Fig. 10

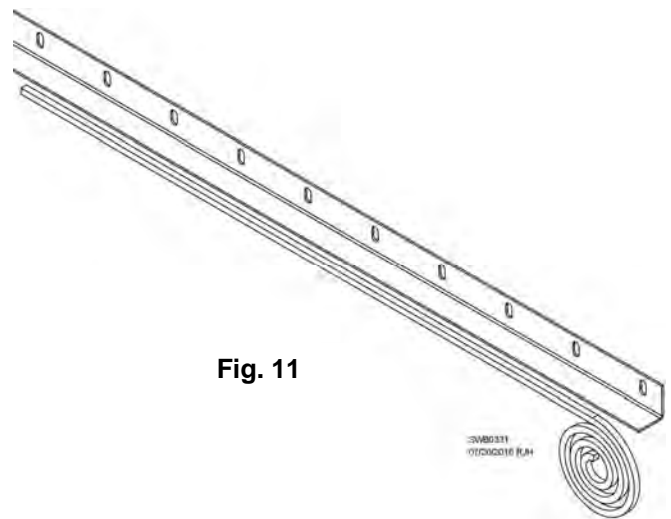
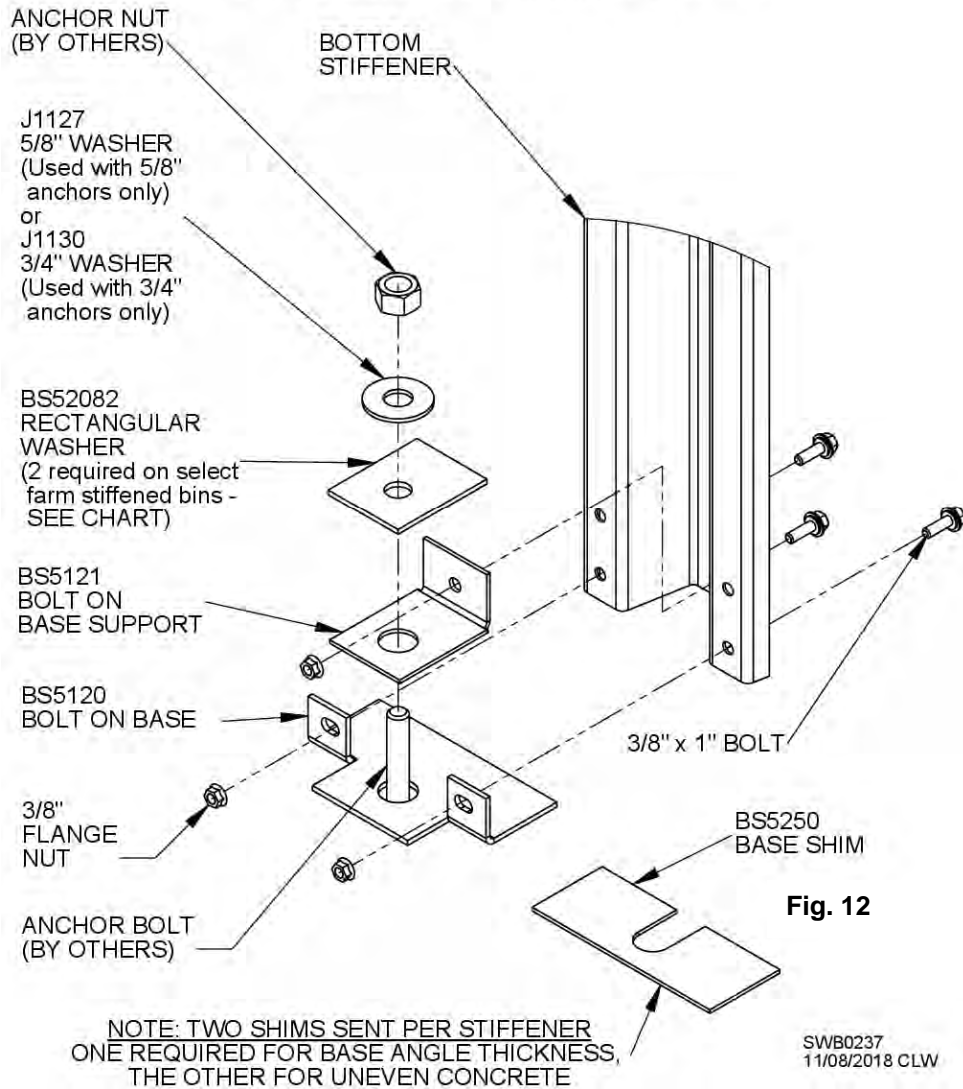

Fig. 11

NOTE: All weight should be taken off of bin jacks before base angle bolts are tightened.

NOTE: SEE CHART IN ANCHOR BOLT SECTION OF THIS MANUAL FOR SPECIFIC WASHER QUANTITIES



Attach bottom stiffener to sidewall using 3/8" bin bolts. Assemble bolt-on base and bolt-on base support to bottom stiffener with bin bolt and flange nut. Each stiffener will include two shims. One shim is required for thickness of bolt-on base angle. An extra shim is supplied for allowances of uneven concrete surface. See Fig. 12. Attach final stiffener splice and tighten bolts.

Ensure stiffener anchor plates clear foundation anchor bolts and that stiffener anchor pads rest on foundation. One shim per stiffener is required. Shim as necessary any stiffeners not in contact with concrete. Always fill gaps, but never force shims into place.

NOTICE: Failure to ensure proper shimming may result in damage to bin structure.

Ensure circularity of bin and check seal. If foam base sealer is not used, seal inside of bin to concrete foundation using a sealing compound.

Assemble rectangular washer(s) and/or appropriate round washer and nut to anchor bolts. See Farm Stiffened Bin Anchors table elsewhere in this manual for correct number of rectangular washers needed. Make sure rectangular washers are installed with long side toward stiffener, as shown in Fig. 12. Tighten as required by anchor bolt manufacturer's specifications.

Reinforcing Sidewall Cutouts

Bin sidewall should be reinforced around any cutout wider than 13" (e.g., conveyors). Use 22" anchor brackets or similar supports for cutouts up to 30" wide. See Fig. 13. Attach a base plate (B5701) to each 22" anchor bracket using two (2) 3/8 x 1" bolts and two (2) 3/8" flange nuts. Attach 22" anchor brackets to sidewall using 3/8" bolts.

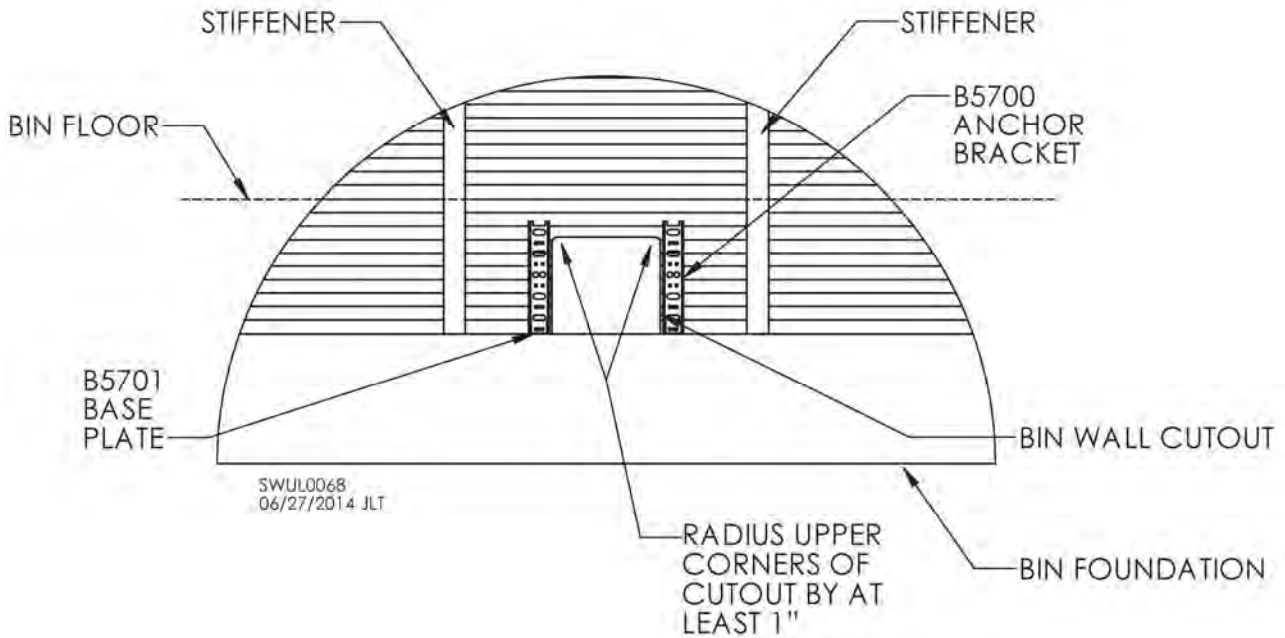

Fig. 13 – 20" cutout reinforced by 22" anchor brackets (B5700) and base plates (B5701)

For a cutout larger than 30" wide, field-weld C-shaped channel pieces together and attach to sidewall as shown in Fig. 14 using 3/8" bolts.

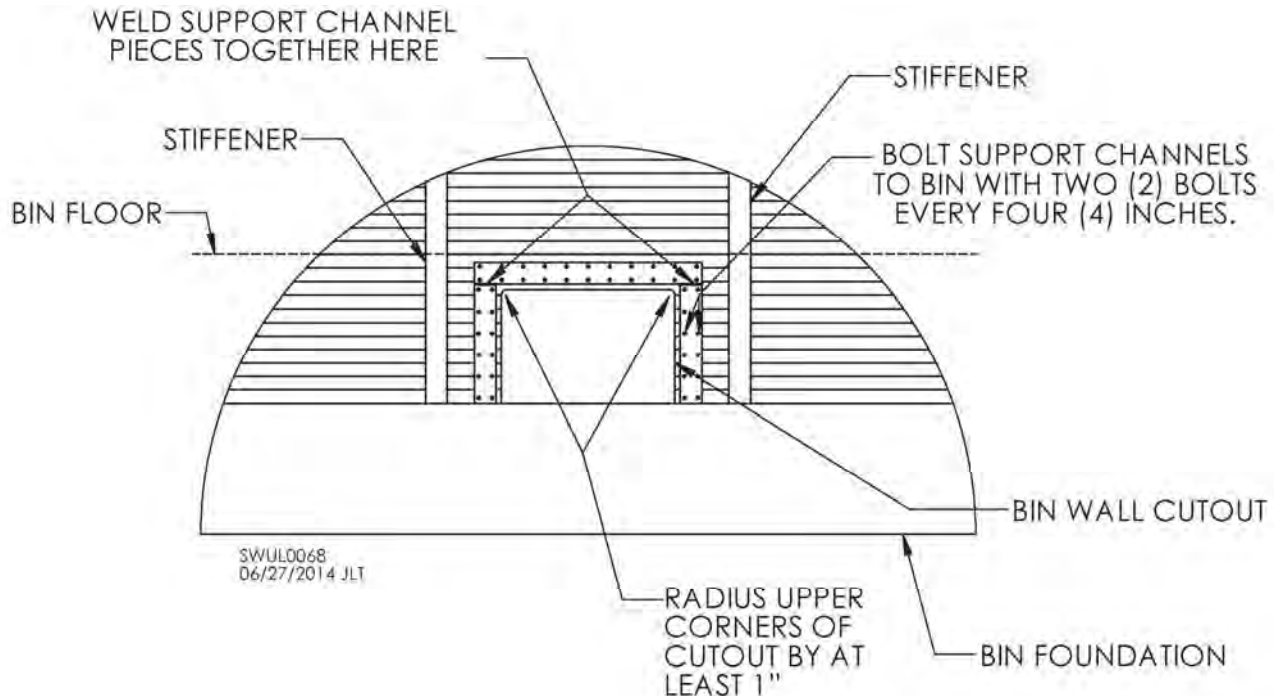

Fig. 14 – 30" cutout reinforced by C-channel

Stiffener Support at Transition Insert

When a stiffener is located above a transition insert, an anchor (threaded rod) must be welded to transition insert so load from stiffener or bracket can be transferred to bin pad.

If stiffener does not rest on top of a vertical member of transition insert, additional support is needed (minimum of 3" square or round tubing) directly under stiffener column. See Fig. 15. This additional support needs to be welded in place.

NOTE: Ensure each piece of transition insert rebar is tied by wire to stemwall hoop rebar.

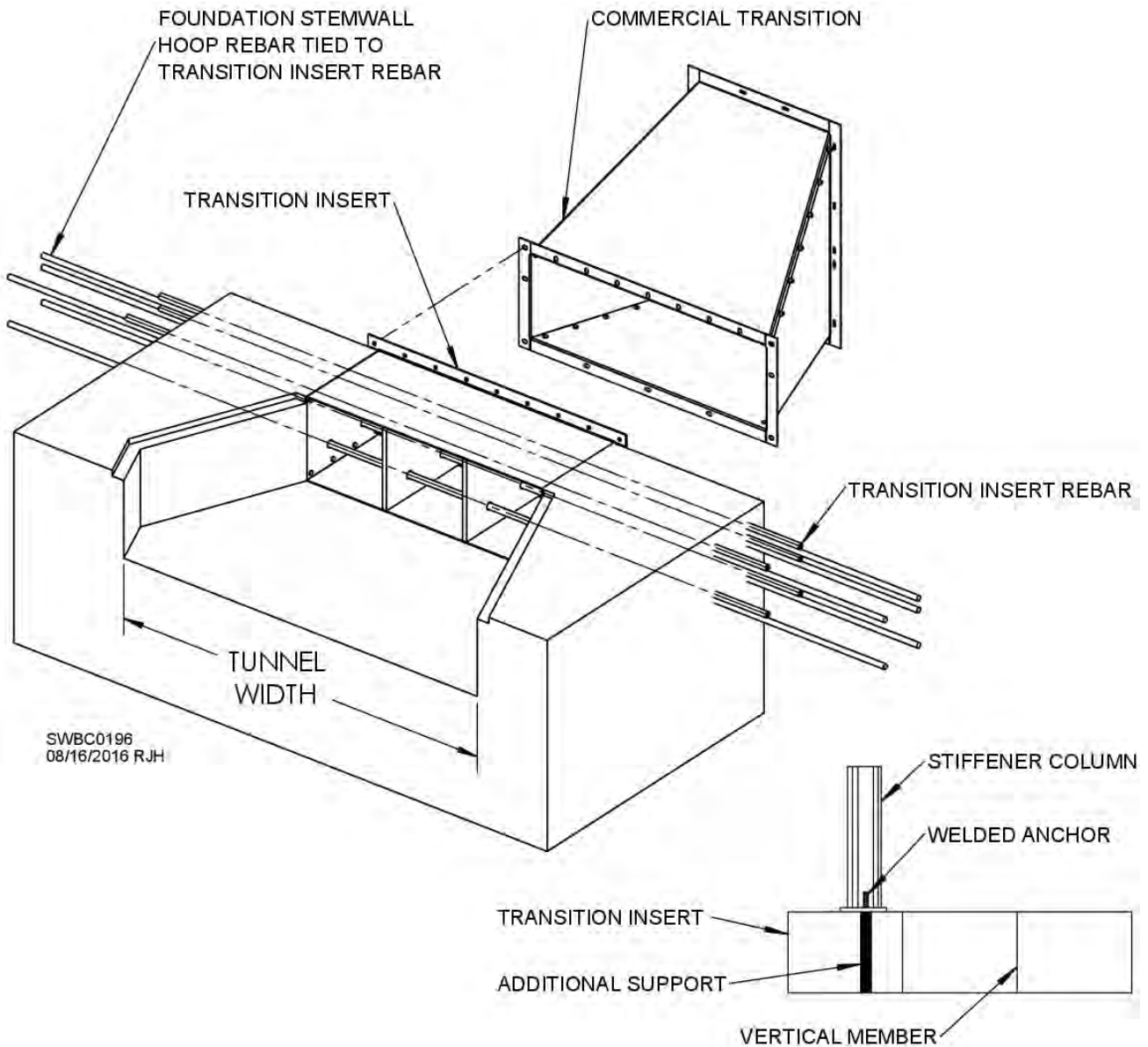
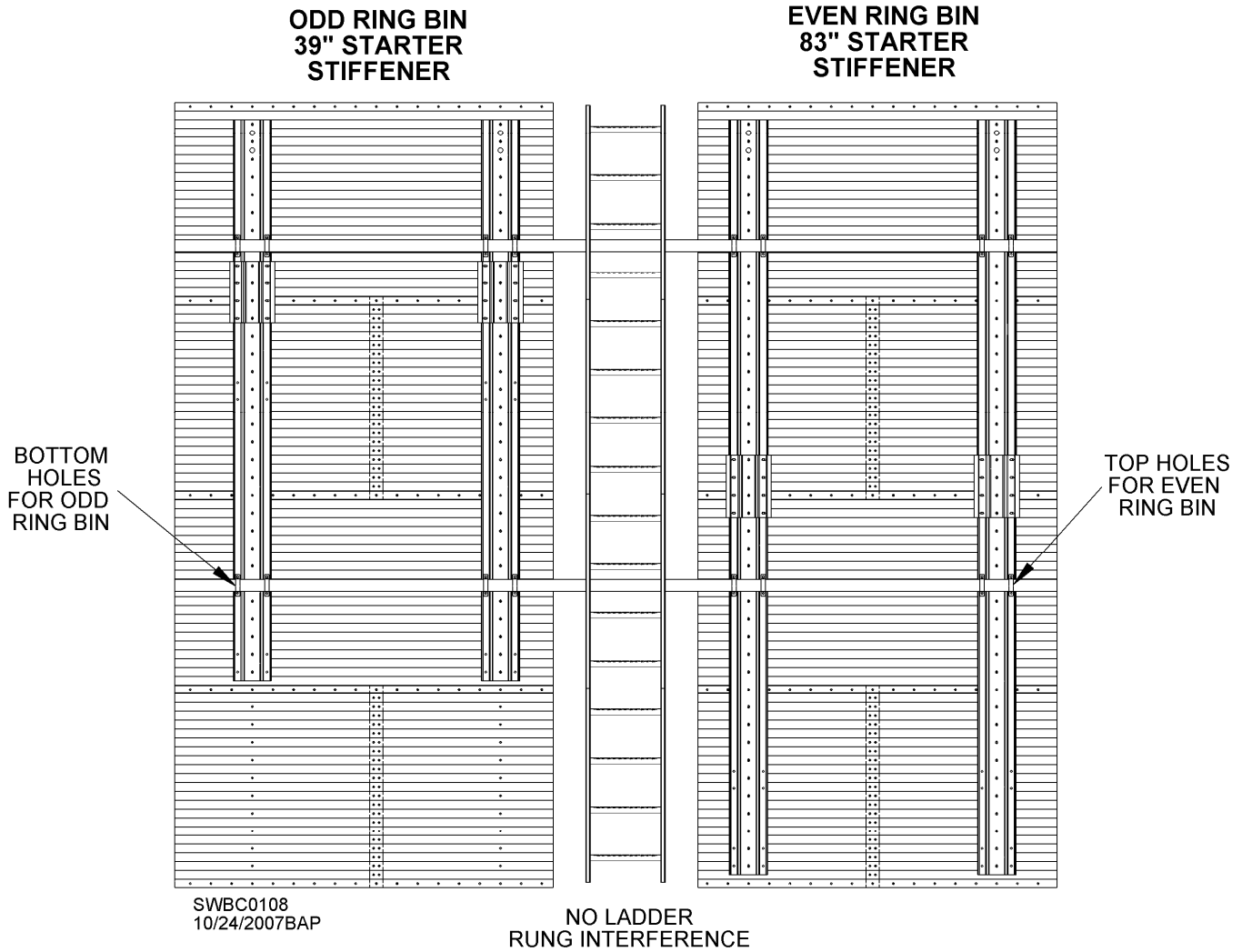

Fig. 15 – Supporting stiffener at transition insert

Wind Ring Assembly



Consult color/gauge chart located either in manual or with sidewall sheets for number of wind rings necessary for bin. Standard wind ring locations are indicated on chart by an “@” symbol. Additional wind rings needed on bin with a sidedraw are indicated by a “+” symbol.

Top stiffeners, 39” & 83”, have only one set of holes for wind ring brackets, located two-thirds from top of top ring. The 88” stiffeners are punched with two sets of holes so that wind ring brackets can be attached in middle of sidewall ring. Use bottom holes on bins with odd number of rings. Use top holes on bins with even number of sidewall rings. See Fig. 1.

Unless otherwise stated on color chart, wind rings are located in top ring, third ring, fifth ring and so on (every other ring starting at top). These wind ring locations meet ASAE Standard S412.1 which leaves at least 1-1/2” below the rung and 4-1/2” above the rung where an obstruction (wind ring) is located.

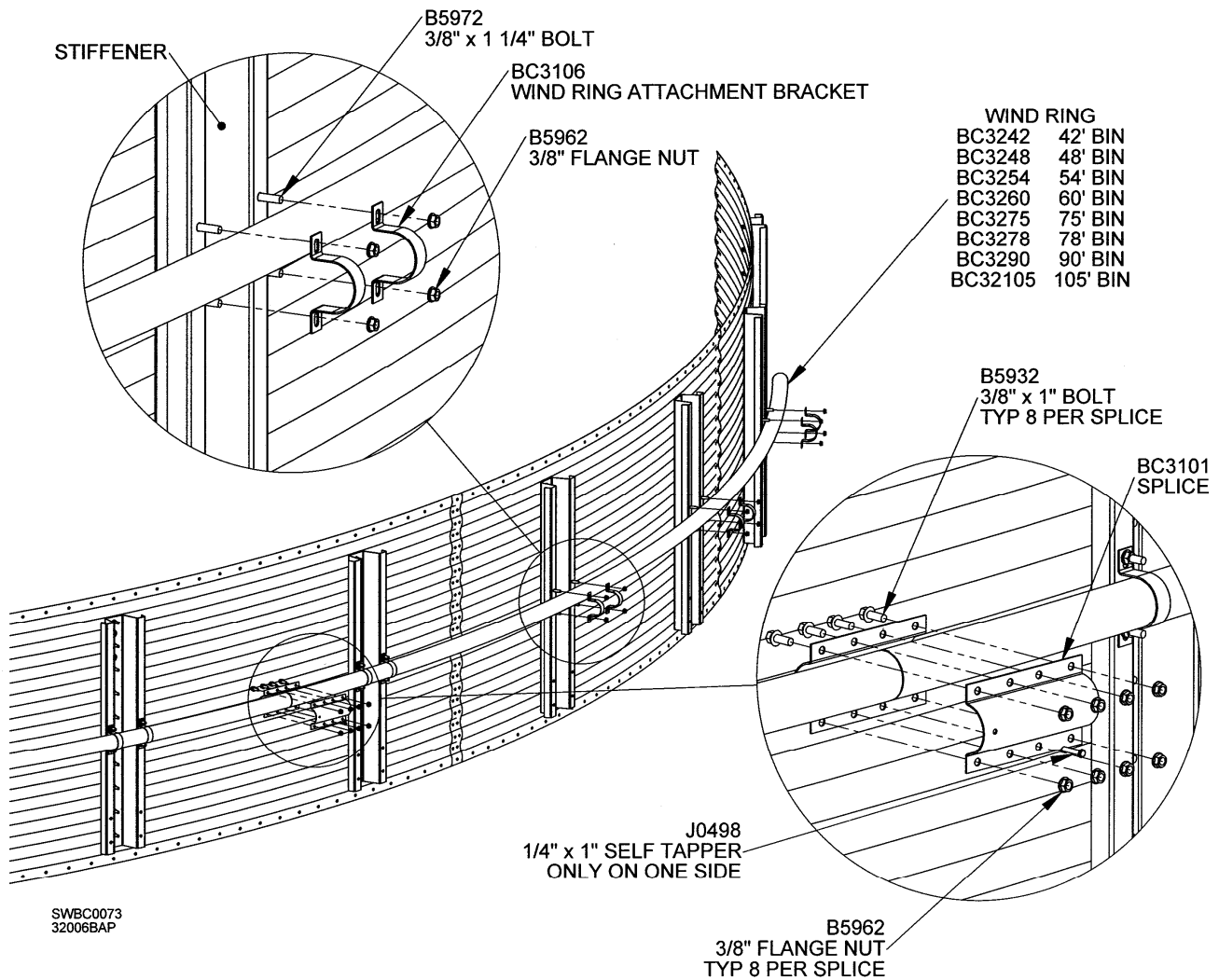

Fig. 2

Loosely attach two wind ring brackets (BC3106) to each stiffener as shown in Fig. 2 using 3/8 x 1-1/4" bolts (B5972) and 3/8" flange nuts (B5962). Insert wind ring sections through brackets.

Butt wind ring sections against each other as shown in Fig. 2. Position splice clamps (BC3101) over ends of wind ring sections. Attach clamps with 3/8 x 1" bolts (B5932) and 3/8" flange nuts (B5962), leaving bolts loose to finger tight. **IMPORTANT:** Splices must be located between stiffeners. Staggering of splices is recommended.

Total length of wind ring sections will be too long for circumference of bin. Last section will need to be cut to butt against first section assembled. Final wind ring section should span at least two sidewall stiffeners.

NOTE: Some wind ring assemblies require that a trimmed piece from a previously assembled ring be used. All leftover sections that are longer than 9' should be saved for possible future use.

Once all wind ring sections have been fastened to stiffeners and spliced, tighten hardware.

Further secure each splice to wind ring using 1/4 x 1" self-drilling screw (J0498) as shown in Fig. 2.

Farm Duty Doors Section

44" & 66" Sidewall Door Installation (D, W, & W1)

NOTE: Use 3/8 x 1" bin bolts for installation of all door frames. See Fig. 8 as needed for reference.

1. Remove inner door panels from frame.
2. Determine top of frame from bottom. Bottom of frame has sloped sill to direct rain away from inner panel.
3. Apply double row of rope caulk to frame flanges. Top flange will receive caulk on outside of flange. Side and bottom flanges will receive caulk on inside, or backside, of flange. See Fig. 1.

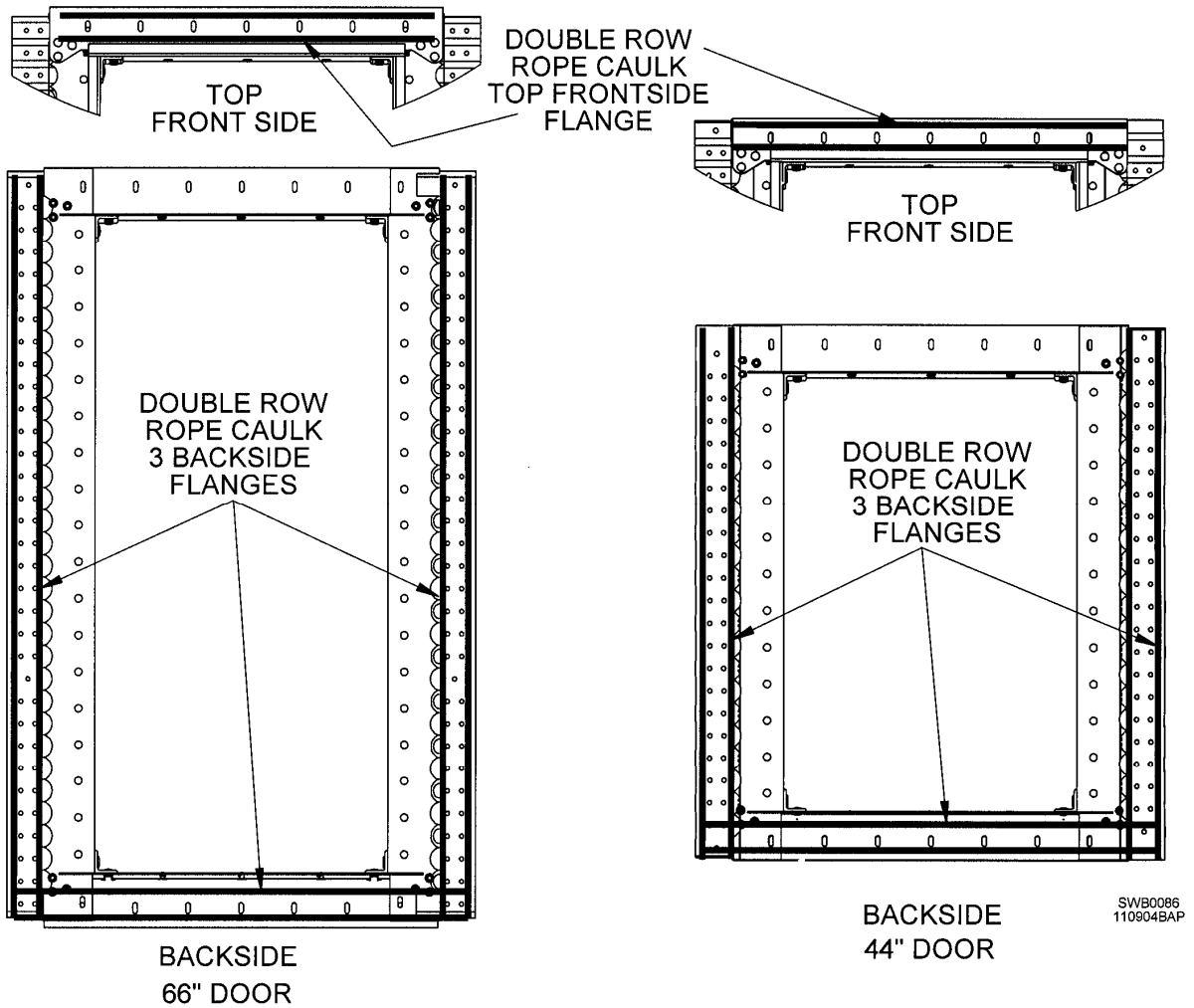

Fig. 1

4. Place door frame into door opening. Top flange of frame will mount inside of sidewall. Side and bottom flanges will mount outside of sidewall panels. Insert 3/8 x 1" bin bolts from outside of bin, leaving nuts loose. Leave bolts out of door hinge support locations. See next page.

NOTE: Second sidewall ring from bottom will have short panels, one on each side of door. 44" door will overlap bottom ring. 66" door overlaps cutout in bottom ring. **NOTE:** See Fig. 7 if installing 44" door on 36' to 48' dia. bin.

5. Place door panels back into door frame. Make sure they close completely over pegs. Lock hammer-head latches. See Fig. 2. (View is from outside of bin.)

6. Tighten door frame bolts in sequence shown in Fig. 2. Complete by working around door frame until all bolts are tightened. No particular sequence is required for rest of bolts.

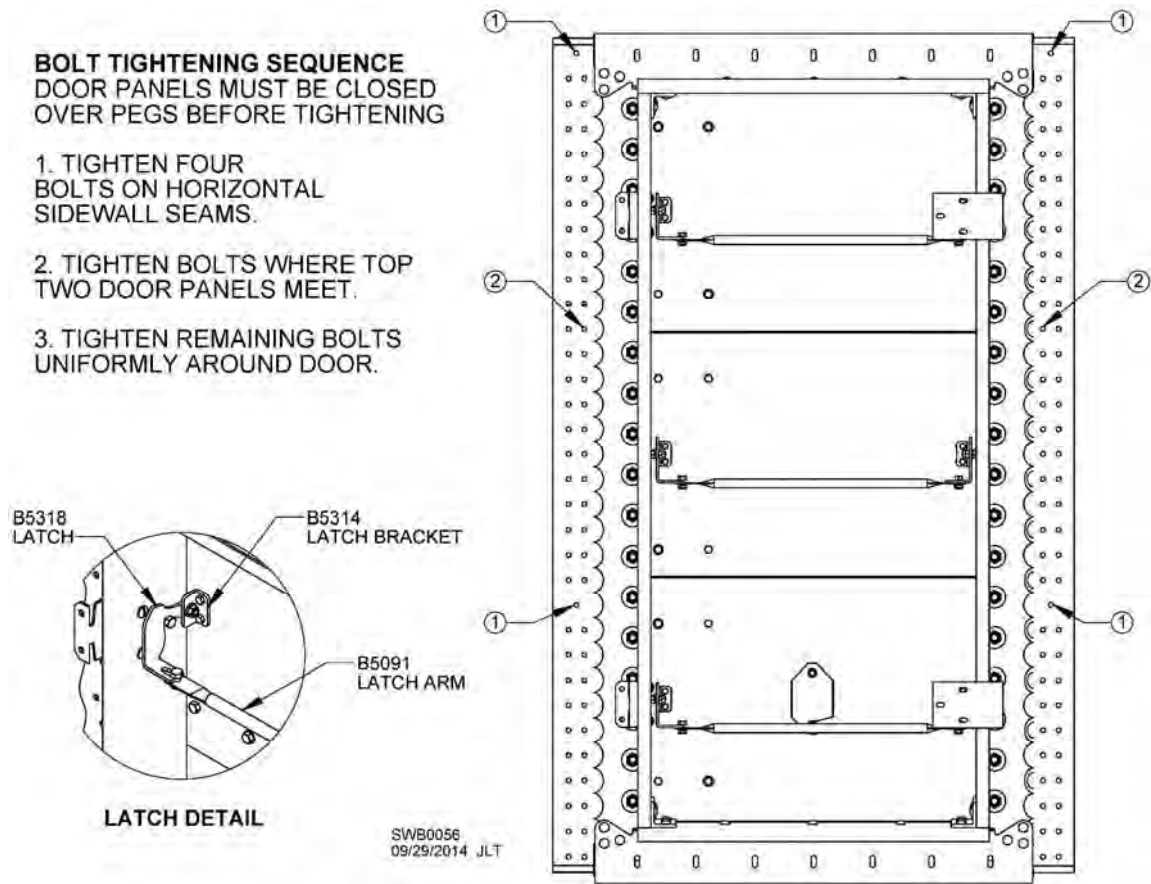

Fig. 2

7. Loosely bolt hinge support pieces (B53421) to bin wall and door frame as shown in Fig. 3. Hinge support pieces are shown in relation to door pegs.

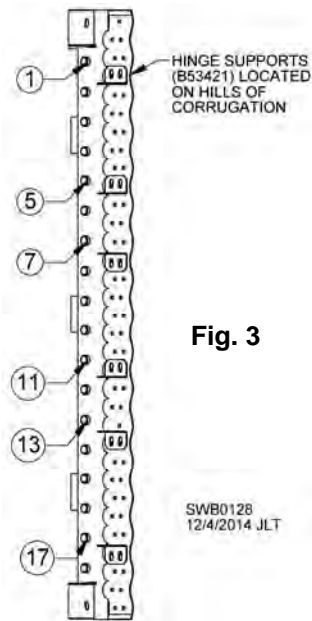

Fig. 3

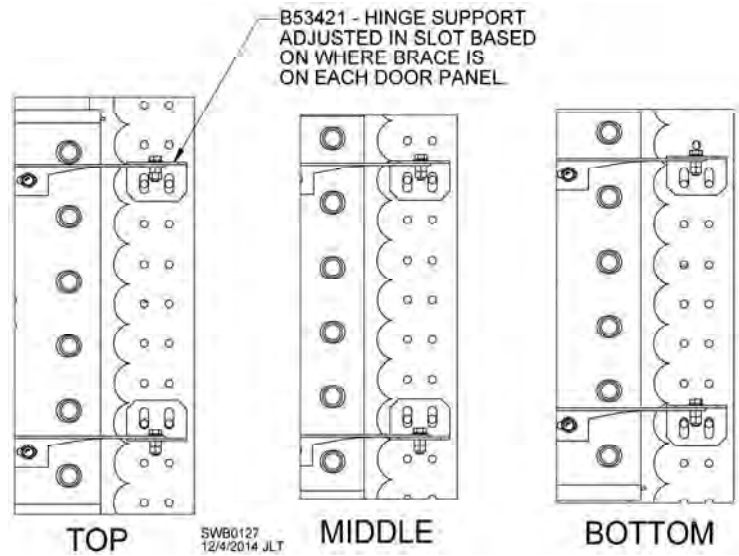

Fig. 4

8. Slide hinge supports up until they touch hinge braces (B53341). Fig. 4 shows how some bolts are below and others are above hinge braces.

9. Loosen 5/16" bolts and slide hinge braces over until hinge holes line up with holes in hinge supports. See Fig. 5. Insert a 3/8" bolt through each hole and turn nut on loosely.

10. Tighten nuts connecting hinge braces to door and hinge supports to door frame.

11. Turn 3/8" nuts all the way onto hinge bolts, then back them off 1/2 to 3/4 turn. Place a second 3/8" nut onto each 3/8" bolt to lock them into place. See Fig. 5. Double-check door panels to ensure 3/8" bolts are not too tight and door panels can open freely and close securely over pegs.

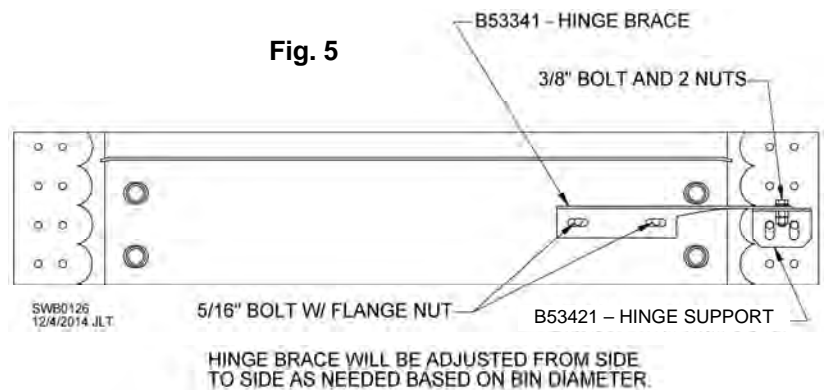

Fig. 5

12. Install outer door panel with hinges in desired direction. Adjust hinges and latches as needed.

13. Install door catch. See Fig. 6. Remove and use existing bolt for catch mounting, or field-drill hole into bin sidewall if an existing bolt is not in correct spot.

14. Attach doorstep below door. It may be possible to align some bolt holes with those in bin sidewall. If not, field-drill four (4) mounting holes. Use 5/16" x 1" bin bolts and 5/16" nuts to attach doorstep to bin.

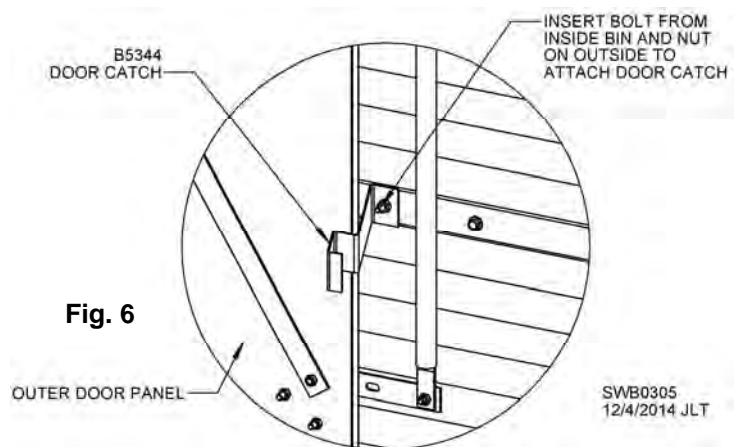

Fig. 6

NOTE: Bolt splice bracket B5461 to corners of 44" doors on 36' diameter and larger bins to help strengthen door corners. Attach as shown in Fig. 7 using 3/8 x 1" bolts that are used for connecting sidewall sheets to frame. Make sure bracket attaches to two holes of each sidewall sheet.

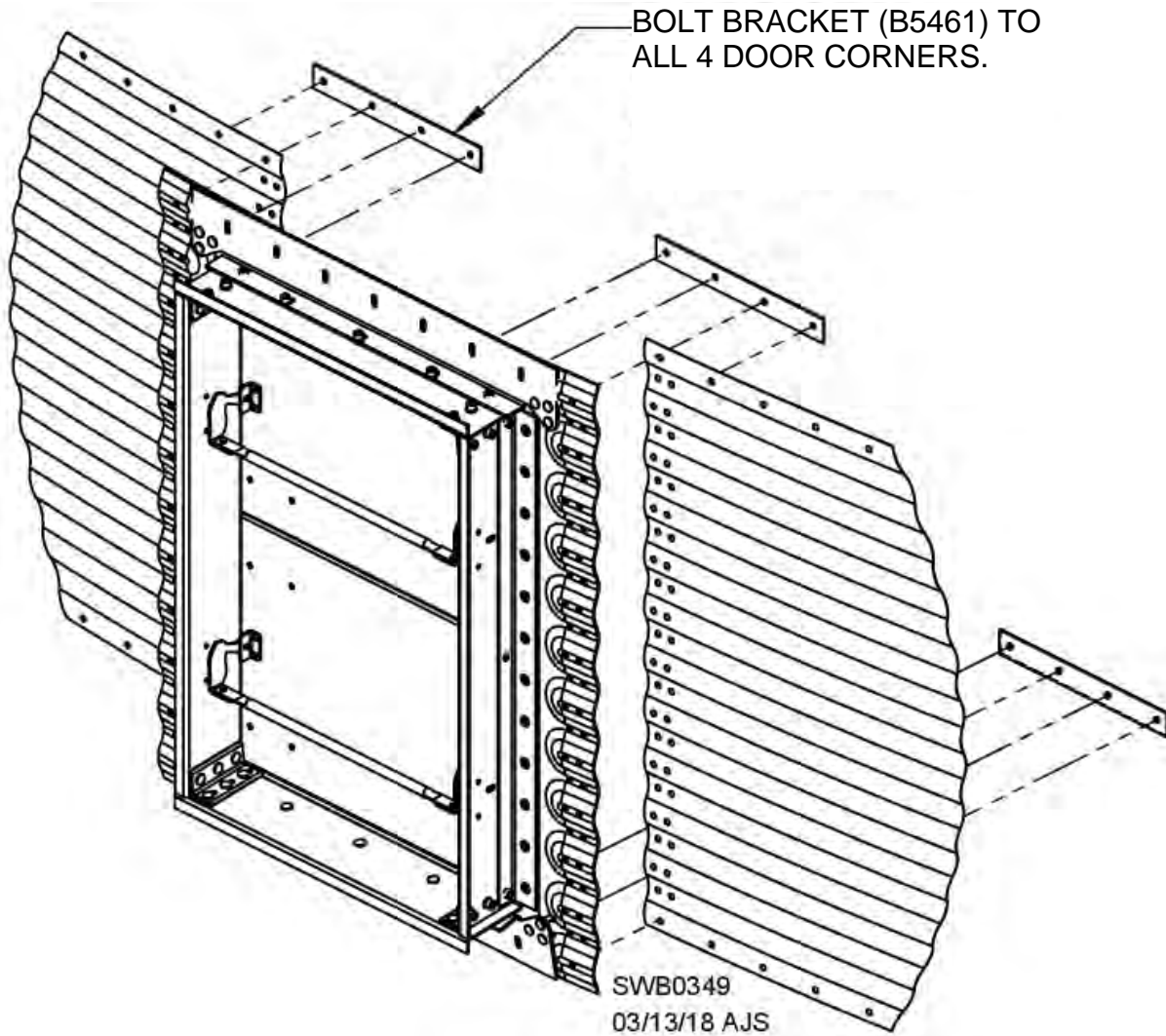

Fig. 7

Components of 66" Door

Fig. 8 and Table 1 show components of 66" door. Components of 44" door are similar, with only two inner door panels.

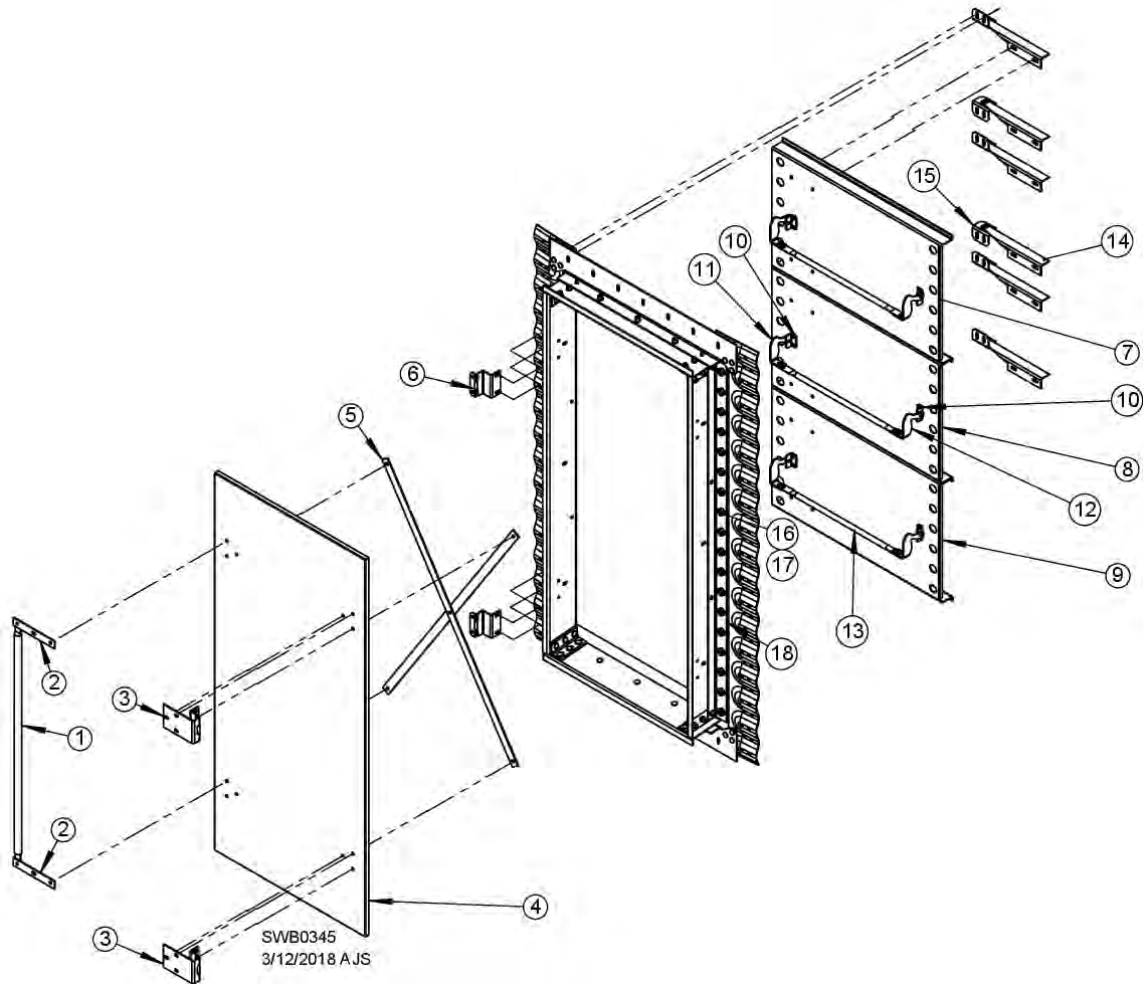

Fig. 8 & Table 1

| ITEM # | DESCRIPTION | COMP. # | QTY. |
|--------|---------------------------|----------|------|
| 1 | Outer door handle | B5356-02 | 1 |
| 2 | Outer door handle bracket | B5356-01 | 2 |
| 3 | Outer door hinge | J2274 | 2 |
| 4 | Outer door | BC331 | 1 |
| 5 | Outer door cross bar | B5328 | 2 |
| 6 | Outer door catch | B5355 | 2 |
| 7 | Top inner door | B53321 | 1 |
| 8 | Middle inner door | B5332 | 1 |
| 9 | Bottom inner door | B5333 | 1 |
| 10 | Inner door latch bracket | B5314 | 6 |
| 11 | Inner door latch, left | B5318 | 3 |
| 12 | Inner door latch, right | B5319 | 3 |
| 13 | Inner door latch arm | B5091 | 3 |
| 14 | Inner door hinge brace | B53341 | 6 |
| 15 | Inner door hinge support | B53421 | 6 |
| 16 | Door peg | B5343 | 36 |
| 17 | Nut, 5/8" – 11 | J1048 | 36 |
| 18 | Door frame side | B5379 | 2 |

Ladders, Safety Cages & Platforms



WARNING: When installing ladder sections, rung treads must face upward. Failure to heed this warning may cause death or serious injury.

Inside 44" & 33" Ladders, Angled Standoff Brackets

Attach ladders to sidewall with angled inside ladder splice brackets (B50791) at every horizontal seam. The only exception will be at top of each ladder assembly. Splice brackets must be moved down 4" to avoid interference with roof sheet and ladder caps. Bins with stirring machine will be shipped with a 33" ladder that attaches below stirring machine track. See Fig. 1.

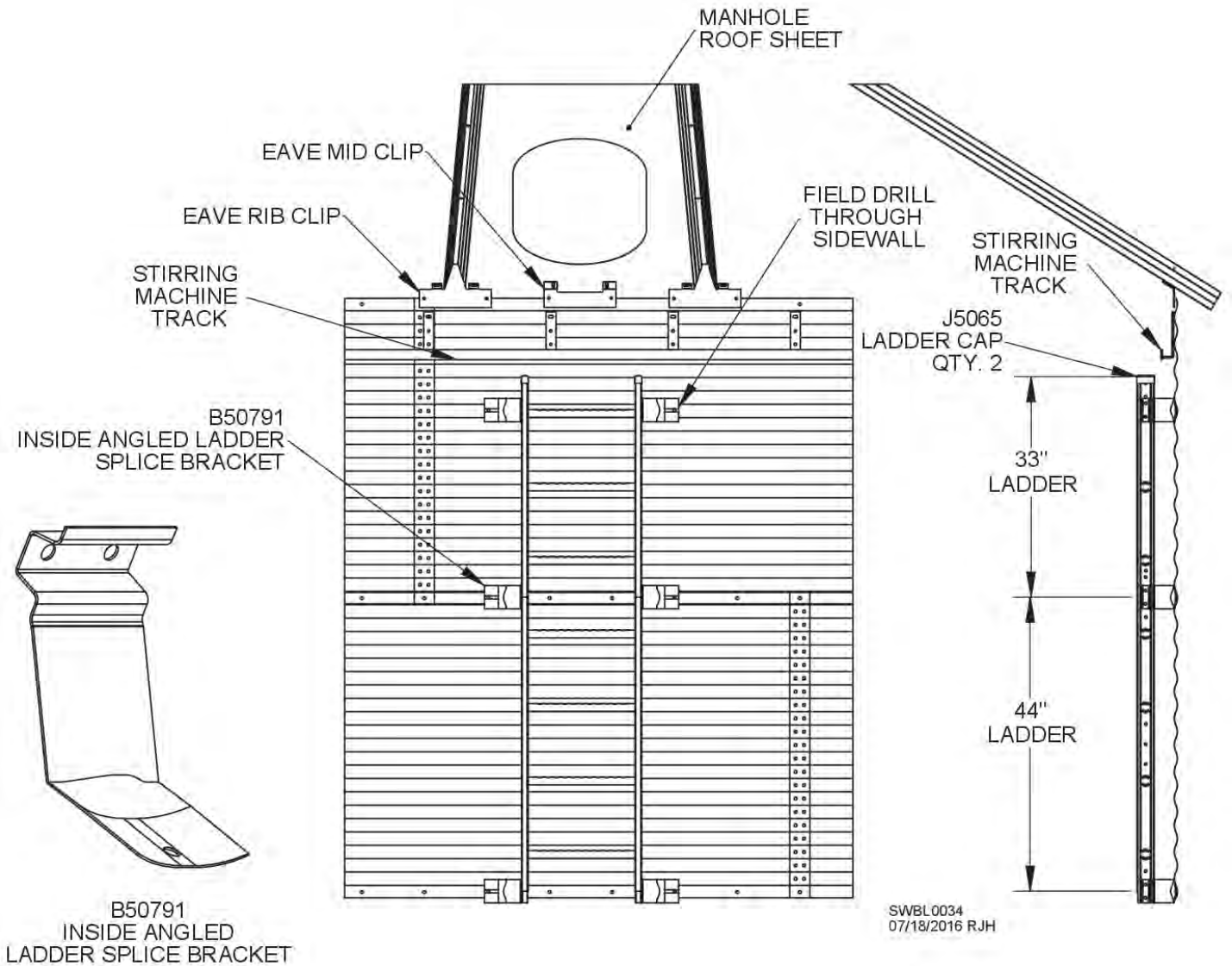

Fig. 1

NOTE: 3/8" hardware is used to assemble all inside ladder packages.

Insert sidewall/splice bracket bolts from outside of bin to create a watertight seal. If outside ladder brackets are used at that same location, remove washer and place between outside bracket and sidewall. Ladder should be centered under manhole opening. **NOTE:** If inside ladder package is ordered, every sidewall ring except bottom one will have ladder attached to it.

Inside 44" Ladders, 90° Standoff Brackets

Attach ladder to sidewall with 90° inside ladder splice brackets (B5079) at every horizontal seam. See Fig. 2. The only exception will be at top of each ladder assembly. Splice brackets must be moved down 4" to avoid interference with roof sheet and ladder caps.

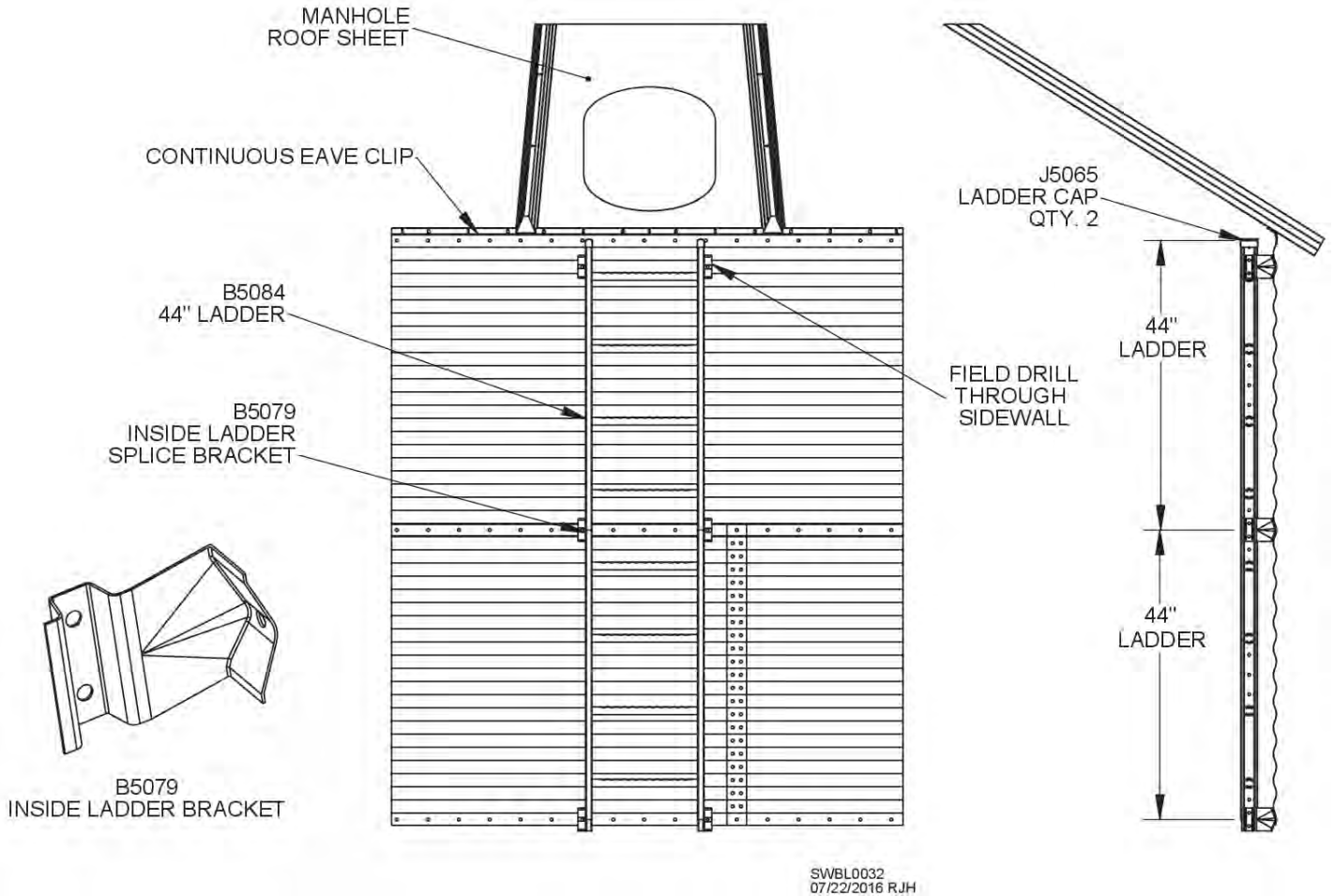

Fig. 2

NOTE: 3/8" hardware is used to assemble all inside ladder packages.

Insert sidewall/splice bracket bolts from outside of bin to create a watertight seal. If outside ladder brackets are used at that same location, remove washer and place between outside bracket and sidewall. Ladder should be centered under manhole opening. **NOTE:** If inside ladder package is ordered, every sidewall ring except bottom one will have ladder attached to it.

Additional Inside Ladder Support Brackets

| Bin Height | Set(s) of Support Brackets | Horizontal Seam Used for Bracket Attachment* |
|------------|----------------------------|----------------------------------------------|
| 6-12 | 1 | 2nd |
| 13-18 | 2 | 2nd, 6th |
| 19-24 | 3 | 2nd, 6th, 10th |
| 25-29 | 4 | 2nd, 6th, 10th, 14th |
| 30 | 5 | 2nd, 6th, 10th, 14 th , 18th |

***Location determined by counting seams from bottom as shown in Fig. 3. Do not count base angle seam.**

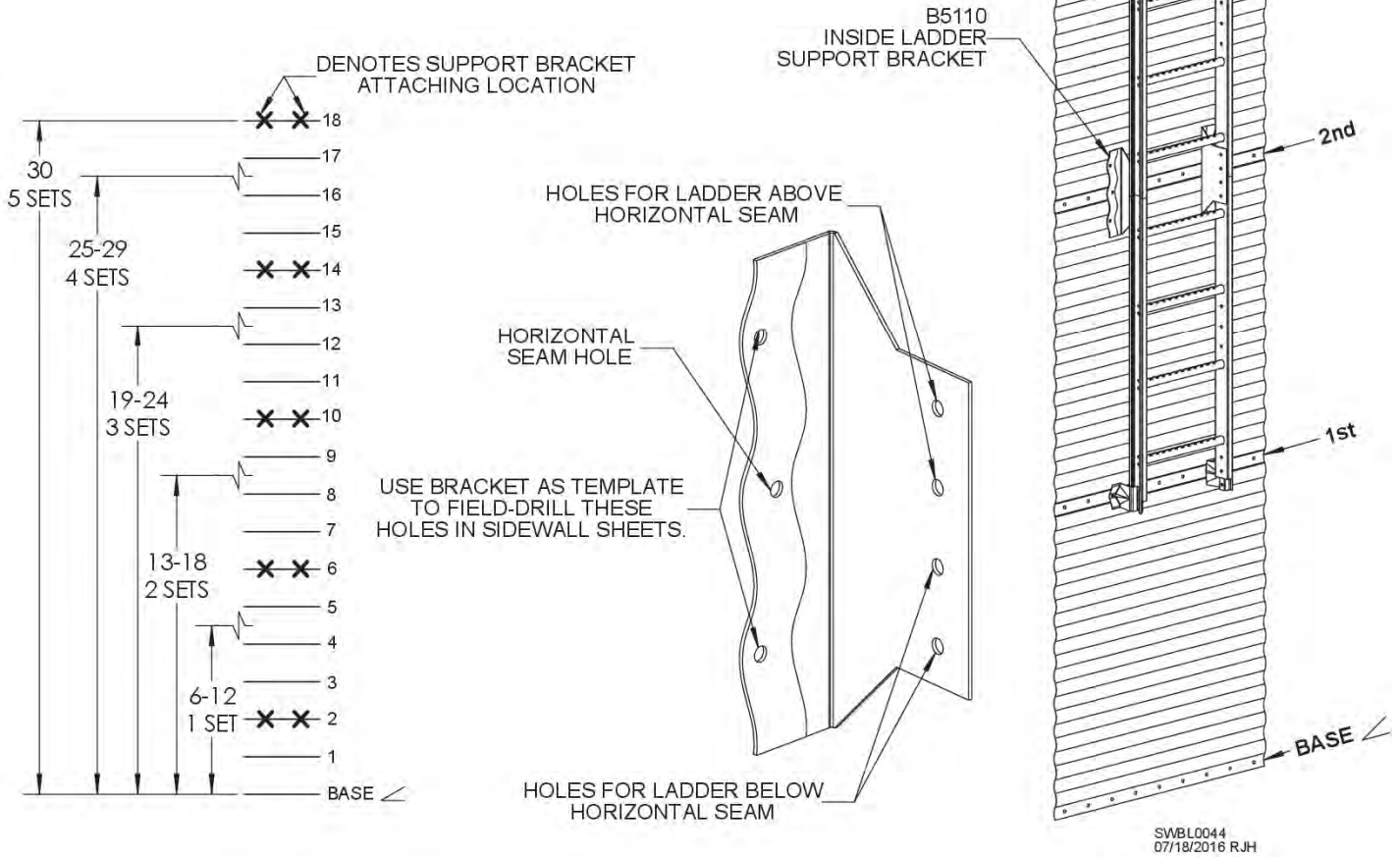

To provide added stability to inside bin ladders, one to five pairs of support brackets (B5110) are provided, depending on height of bin. One pair should be installed in bins with 6 to 12 rings; two pairs in bins with 13 to 18 rings; three pairs in bins with 19 to 24 rings; four pairs in bins with 25 to 29 rings, and five pairs in bins with 30 rings. See guidelines above for attaching locations. Some examples: A 10-ring bin requires one (1) set of ladder support brackets attached at 2nd horizontal seam; a 14-ring bin requires two (2) sets of ladder support brackets, attached at 2nd and 6th horizontal seams; a 22-ring bin requires three (3) sets of ladder support brackets, attached at 2nd, 6th, & 10th horizontal seams.

Install brackets at ladder splice, using existing horizontal seam bolt in middle hole of support bracket. Field-drill one hole above and one hole below horizontal seam as shown in Fig. 3 and secure with 3/8" hardware. Bolts should be inserted from outside of bin. Attach brackets to inside of ladder rails as shown, using holes provided and 3/8" hardware. **TIP:** It may help to mark on supplied color chart the locations of these additional ladder support brackets.

NOTE: Horizontal seams are at top of specified ring. Do NOT count base angle seam.

Outside 44" Ladders

44" ladder sections attach at each sidewall ring. Attach ladders to sidewall with outside ladder splice brackets (B5078) at every horizontal seam. The only exception will be at top and bottom of each ladder assembly. Splice brackets must be moved up or down 4" to avoid interference with roof sheets, landing platform brackets, concrete and ladder caps. See Fig. 4.

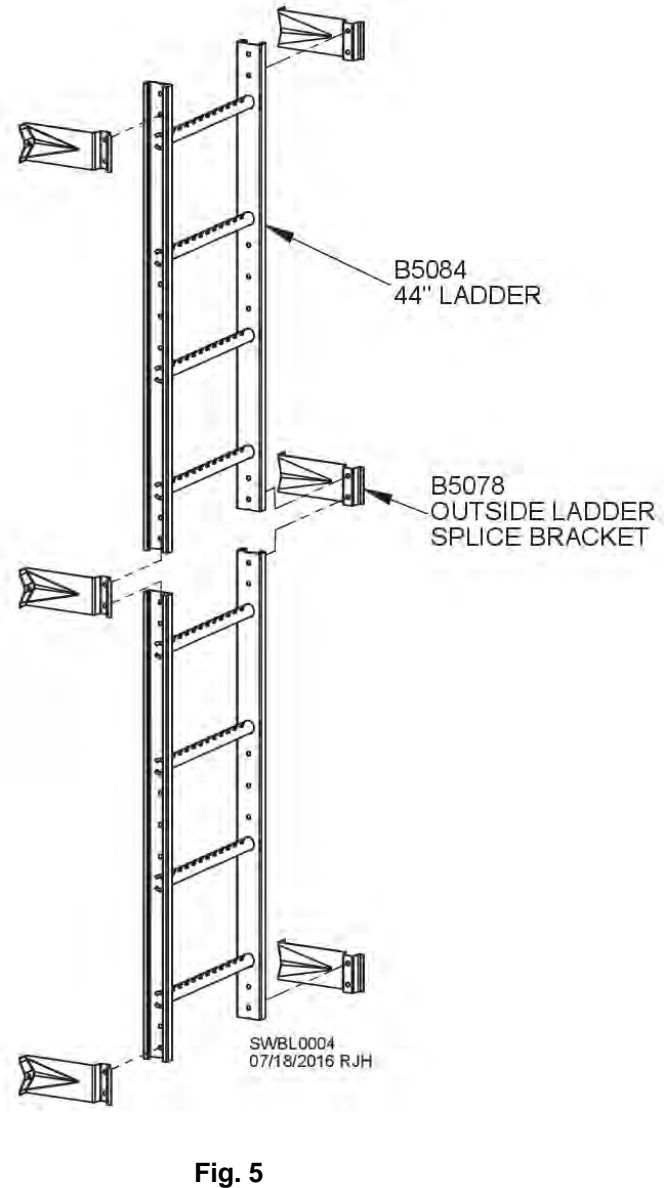
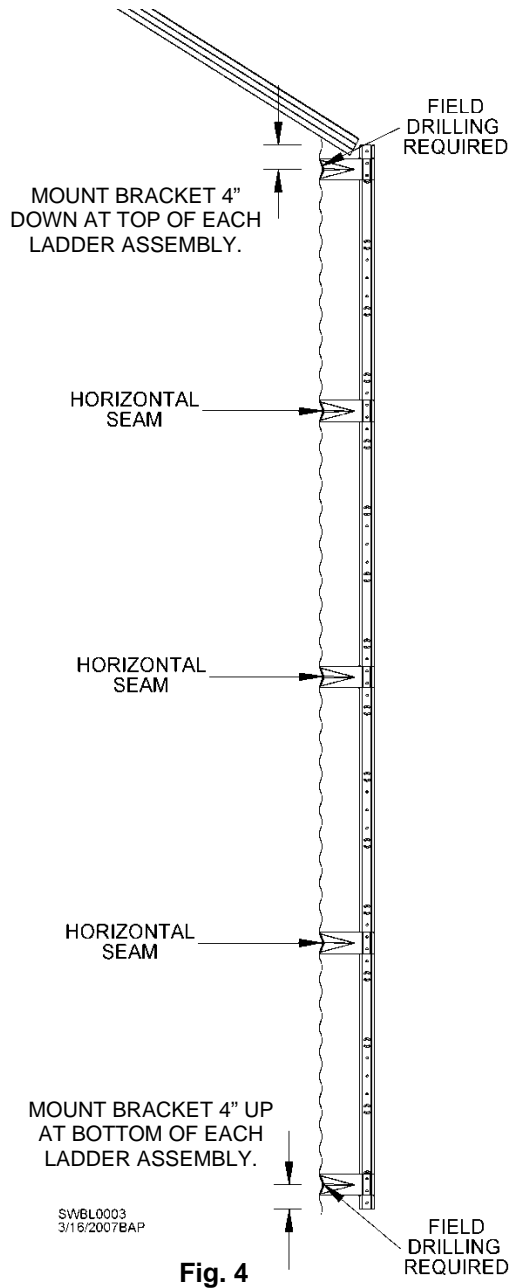

NOTE: 3/8" hardware is used to assemble all ladders, platforms and cages.

Insert sidewall/splice bracket bolts from inside of bin to create a watertight seal. If outside ladder brackets are used at that same location, remove washer and place between outside bracket and sidewall. See Fig. 5.

Ladder Extension (B5020)

Ladder extensions (B5080) are provided with cage and platform packages. Extensions are an option for 3-5 ring ladder packages.

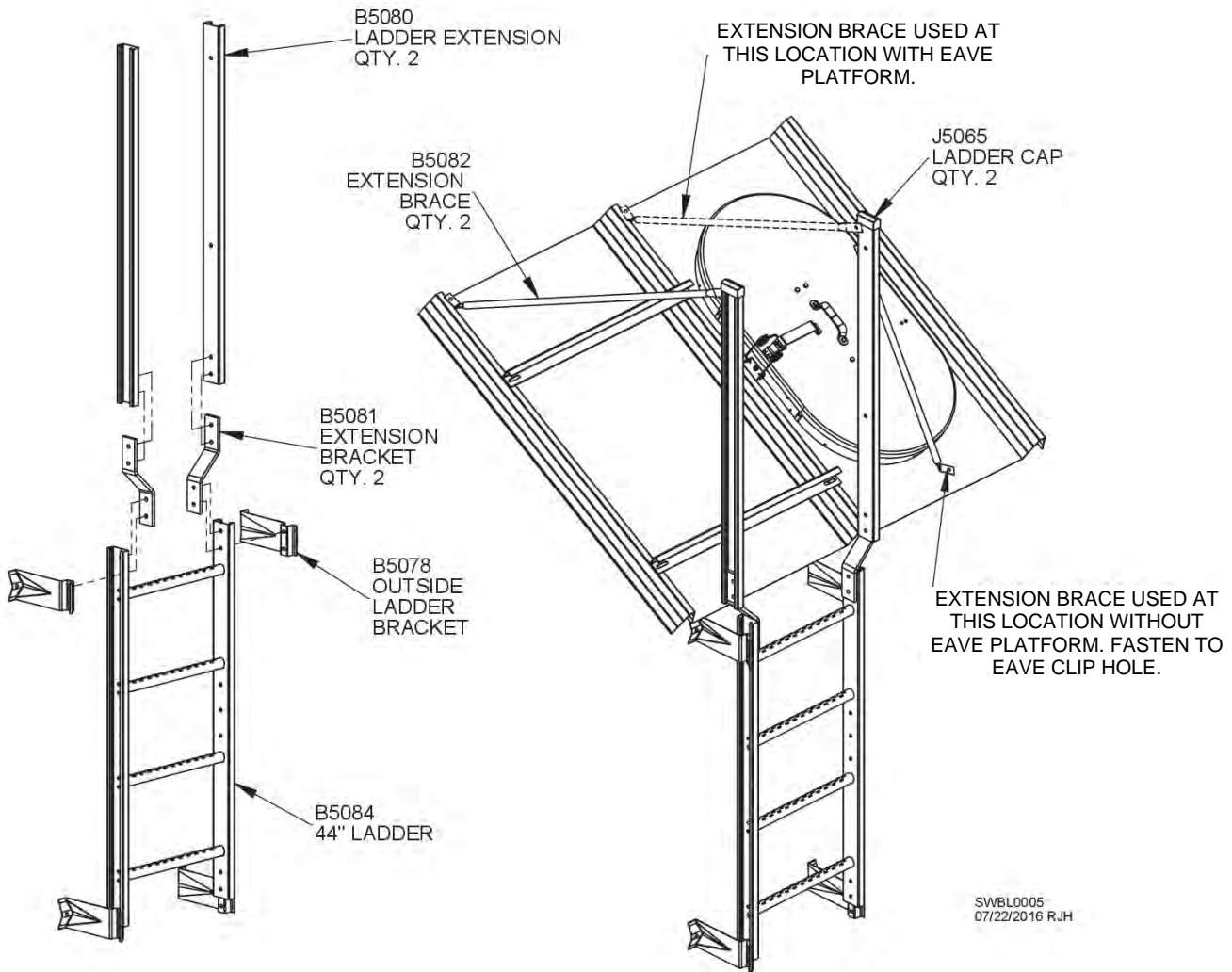

Fig. 6

Ladder extensions (B5080) are provided as a means to walk “through” ladder onto roof steps. Extensions are connected to ladder rails using offset extension brackets (B5081). When attaching extension bracket to ladder, hardware will be inserted through three (3) pieces (extension bracket, ladder siderail and ladder bracket). Align extension bracket with top holes on ladder siderail as shown in Fig. 6, then attach ladder bracket to siderail and extension bracket. Attach other end of ladder bracket to sidewall. Attach ladder extensions to extension brackets and stabilize to roof ribs using extension braces. See Fig. 6. Attach with 3/8” hardware. Slide plastic ladder caps over tops of extensions. **NOTE:** Field drilling may be required when attaching extension braces. Extension braces (B5082) may need to be attached by a different means to avoid interference with manhole.

Extension and Standard D-ring

Fig. 7 shows differences between an extension D-ring (B5089) and a standard D-ring (B5085). Extension D-rings are used only with ladder extensions. Standard D-rings are used only on ladders. Both D-rings have same outside dimensions. Differences are at connection points. See Details A & B of Fig. 7.

EXTENSION D-RING

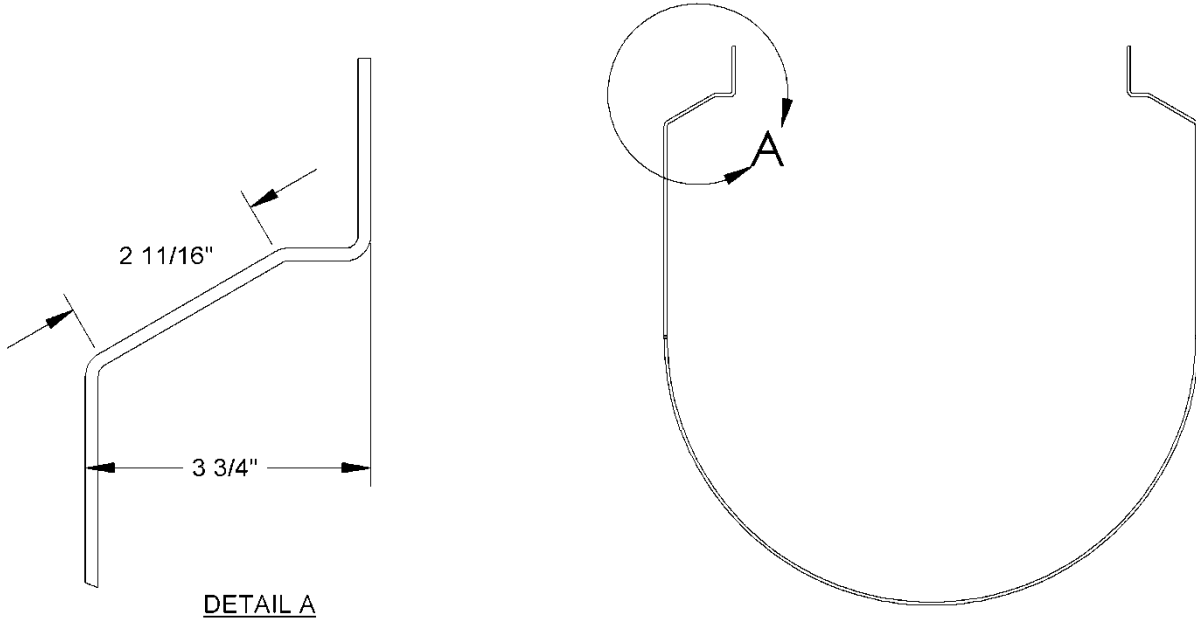

STANDARD D-RING

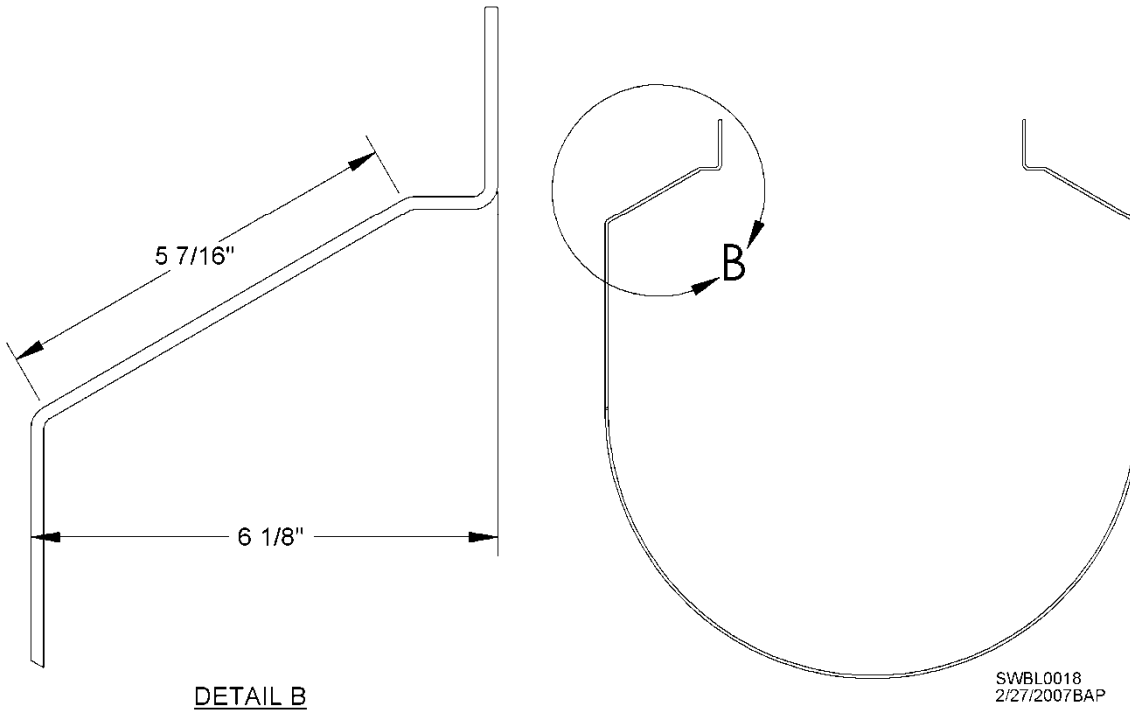

Fig. 7

Ladder Cage/No Platform

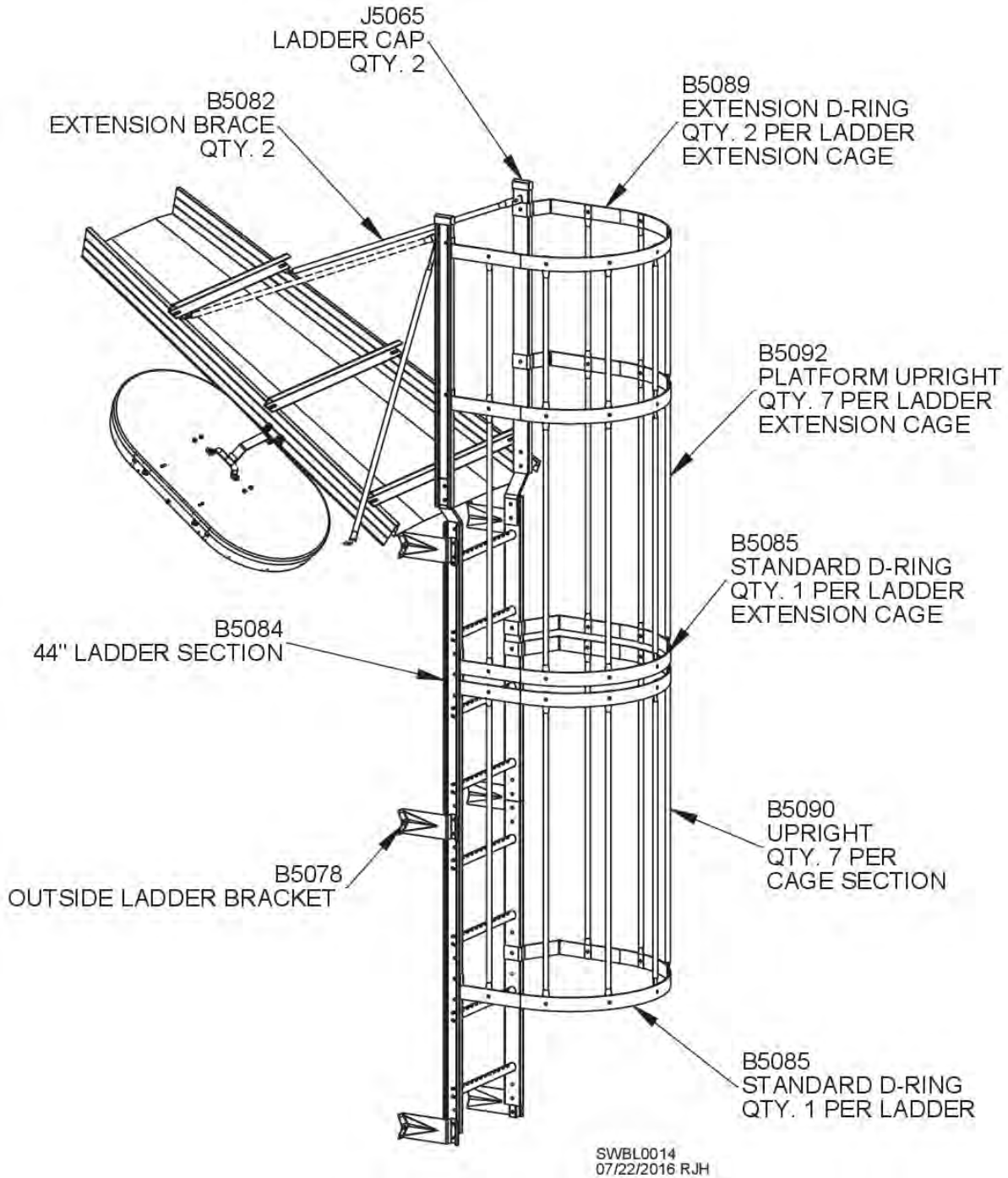

Fig. 8

Some ladder and cage assemblies do not require use of platforms. For these, an extension package is available as an option to access roof steps. If safety cage is used on these ladders, extension D-rings (B5089) are required. They attach to ladder extensions as shown in Fig. 8. Connect platform uprights (B5092) to D-rings with 3/8" hardware and tighten. See Fig. 8. Attach extension braces (B5082) as shown to avoid interference with manhole. If no manhole is present, both braces can be attached at same height on roof ladder.

44" Cages with 22" Flared Bottoms

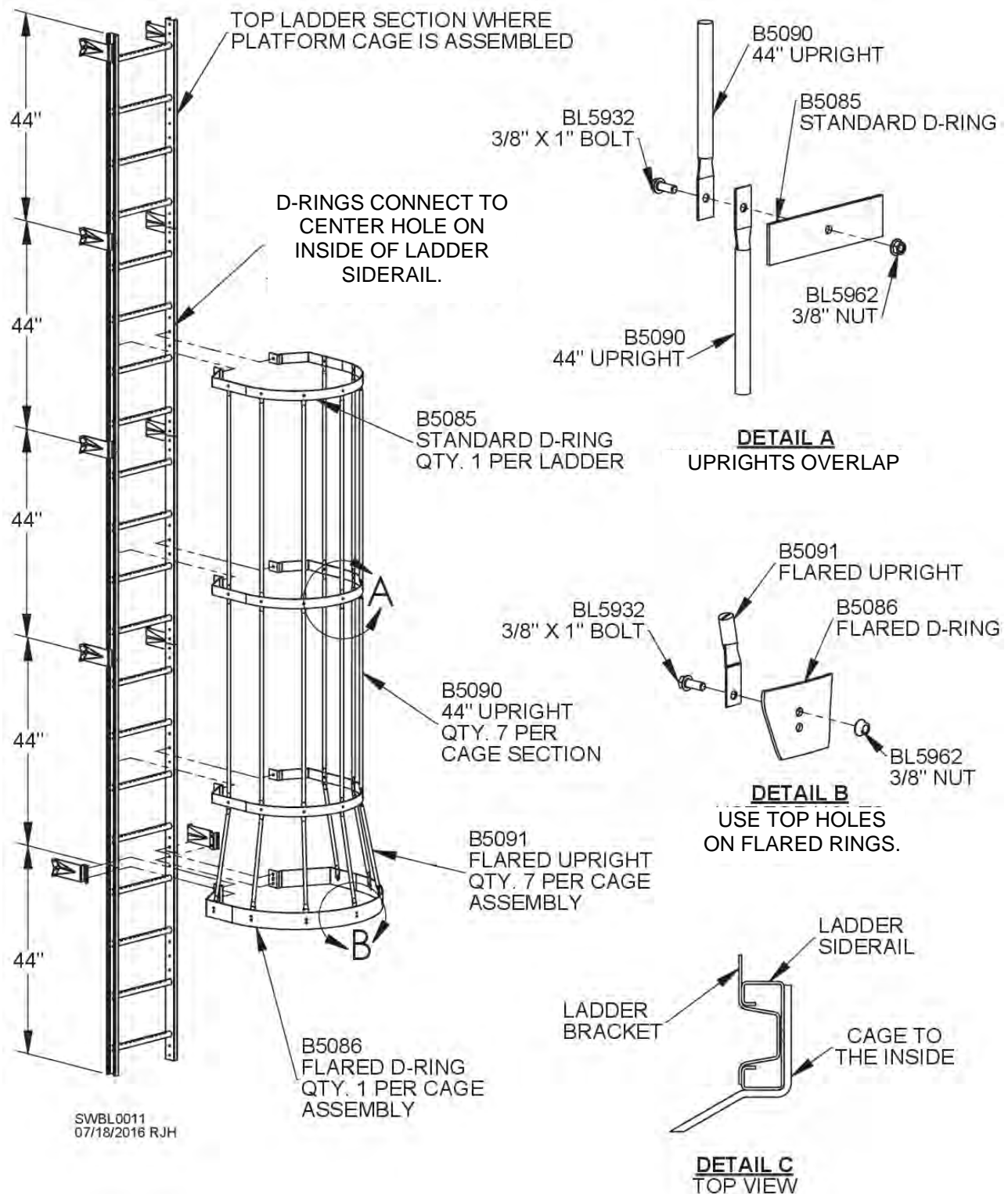
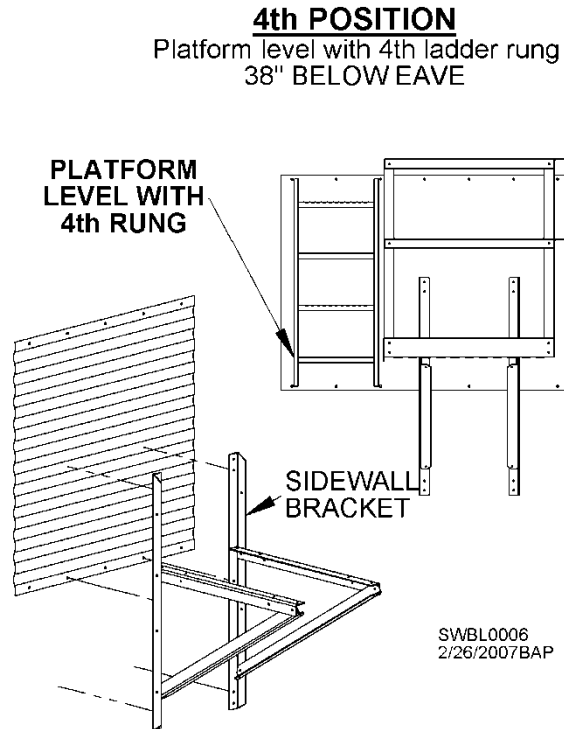
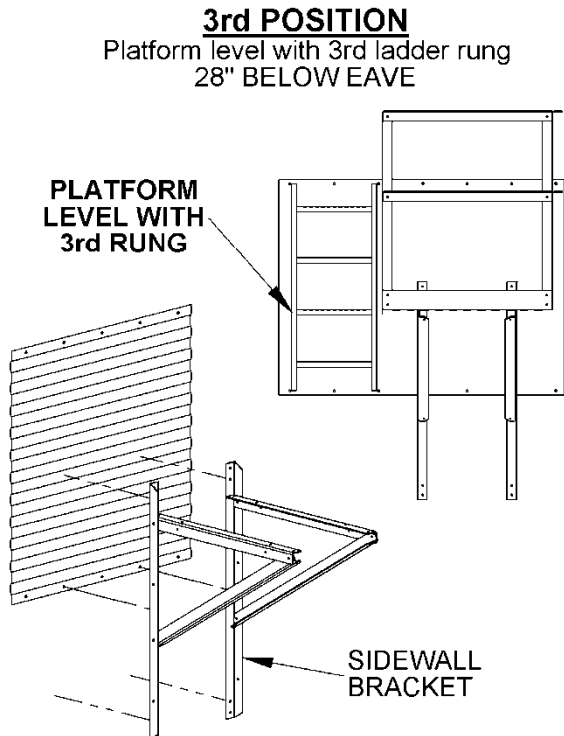
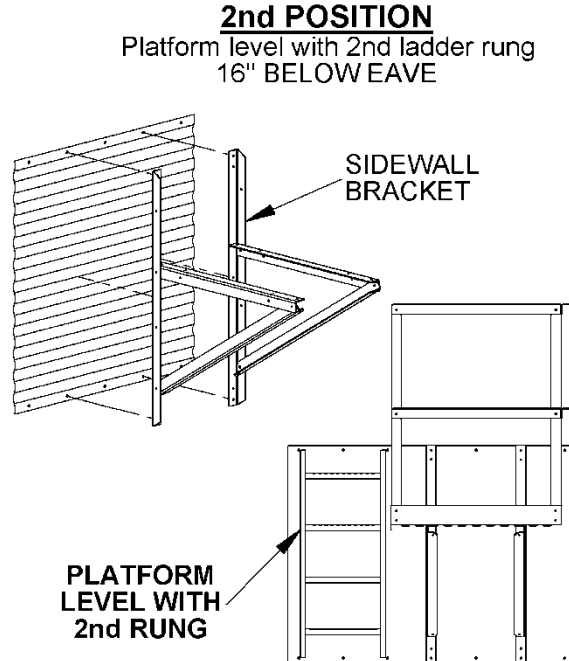
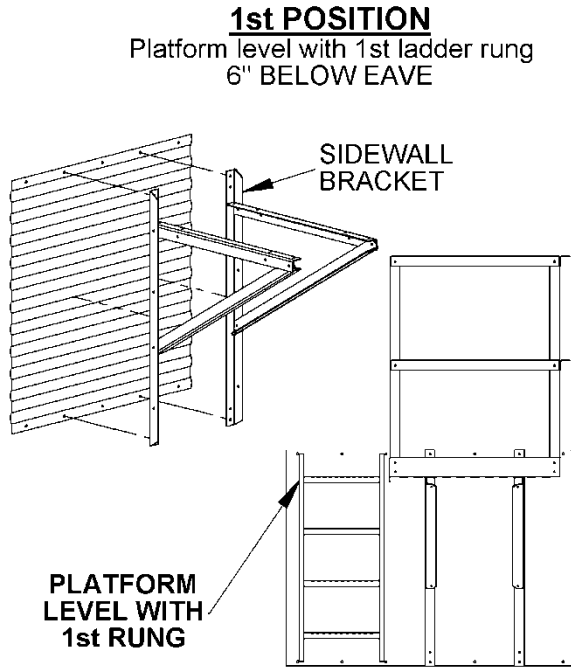

Fig. 9

As bin is built, continue to add appropriate ladder and cage sections. Refer to following pages for specific ladder and cage layouts. Cage sections consist of standard D-rings (B5085) and seven (7) 44" uprights (B5090). Standard D-rings attach to inside of ladder siderails. A flared D-ring is always used at bottom of each cage assembly. Top D-ring must be connected to center of top ladder. This allows bottom flared D-ring to be at proper height above the next surface (concrete or landing platform). Attach standard D-rings and uprights to ladder sections with 3/8" hardware. See Fig. 9.

36" Platform Locations

Fig. 10 shows the four (4) positions where platform can be located. **NOTE:** Each location is at same level as a ladder rung in first ring. For 1st & 2nd positions, 44" sidewall bracket mounts to sidewall at horizontal seams and in middle of sidewall sheet. For 3rd & 4th positions, middle hole of 44" sidewall bracket mounts at horizontal seam and top and bottom of bracket are attached in middle of sidewall sheets. Field drilling is required.



SWBL0006
2/26/2007BAP

Fig.10

36" Platform Starting Location

Location of ladder is a critical factor in constructing a grain bin. Careful thought must be given to position of sidewall and roof ladders in relationship to overall layout of site and auxiliary equipment. Location of roof ladder and manhole during bin construction will establish location of sidewall ladder. Sidewall ladder and eave platform must be in line with roof ladder and manhole. Fig. 11 shows eave platform starting location on a sidewall sheet with 9-3/8" bolt hole spacing. Lower drawing shows ladder centered between stiffeners.

IMPORTANT: When attaching ladder and safety cages to a stiffened bin, locate ladder between two (2) stiffeners. When constructing bin with raftered substructure, be certain manhole is not aligned over a rafter. Suggestion: Locate roof ladder on roof sheet to right of primary rafter. Manhole can then be placed on sheet to right of roof ladder. This ensures that eave platform will be centered over a stiffener. Platforms are designed to ensure that when additional ladder columns are offset, they are not centered over a stiffener.

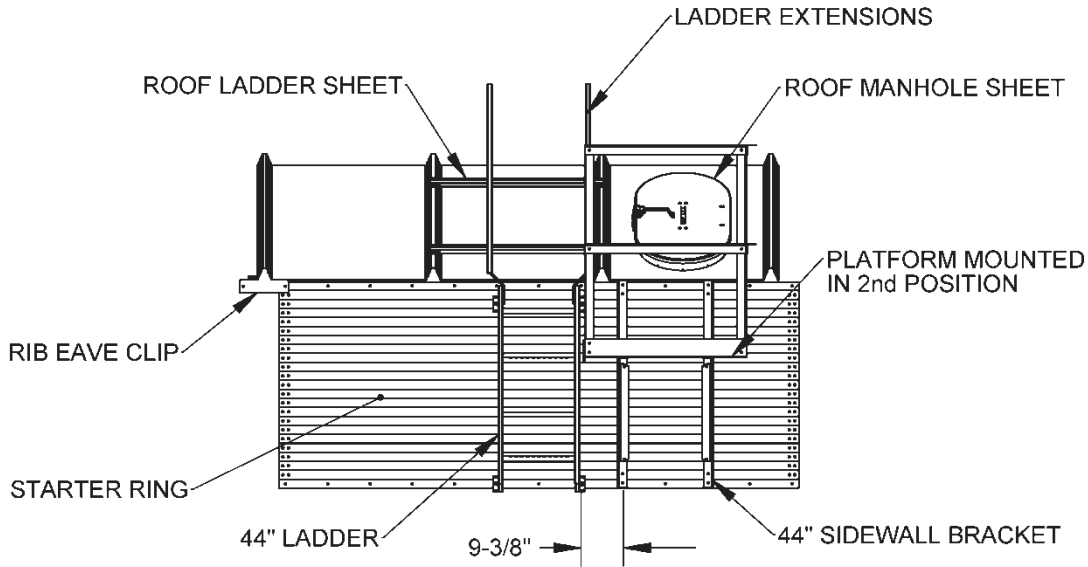
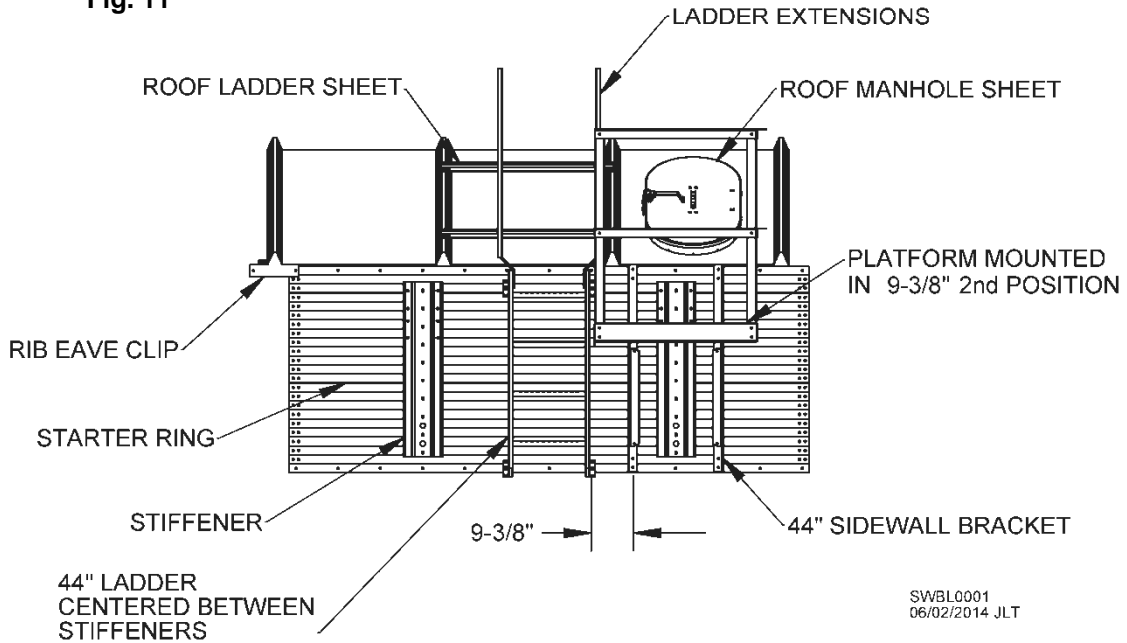

Fig. 11



SWBL0001
06/02/2014 JLT

36" Platform Assembly

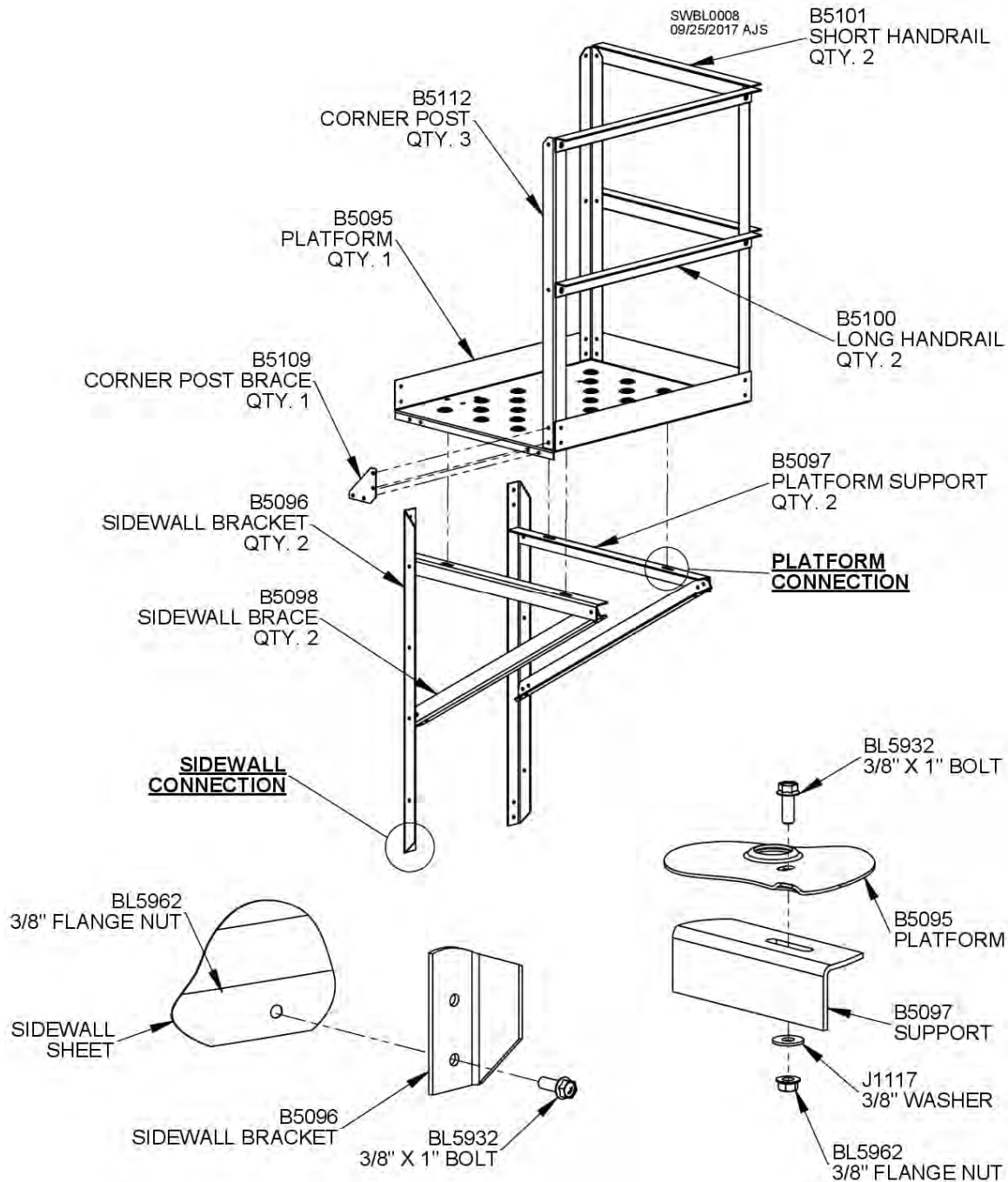

Fig. 12

Entire platform assembly is constructed with 3/8" hardware. Begin by attaching sidewall brackets (B5096) to sidewall. Some holes may need to be field-drilled in sidewall depending on which position was chosen for platform. Attach platform supports (B5097) and sidewall braces (B5098) to sidewall brackets as shown in Fig. 12. **NOTE:** Leave all bolts loose until assembly is complete.

Attach platform (B5095) to platform supports and fasten corner posts (B5112) to 4" toeboard. Fasten long and short platform handrails to corner posts. See Fig. 12. Tighten platform assembly. **HINT:** If assembling platform with safety cages, corner post brace (B5109) and post that it braces can be left off of platform assembly at this time.

Top & Bottom Corner Posts, 36" Platform

Fig. 13 shows the four locations platform can be positioned. Top and bottom corner posts will not be moved vertically. Only the platform assembly itself will be able to move up or down on corner posts. **NOTE:** Top half D-ring fastens to top hole in top corner post and bottom half D-ring fastens to bottom hole of bottom corner post.

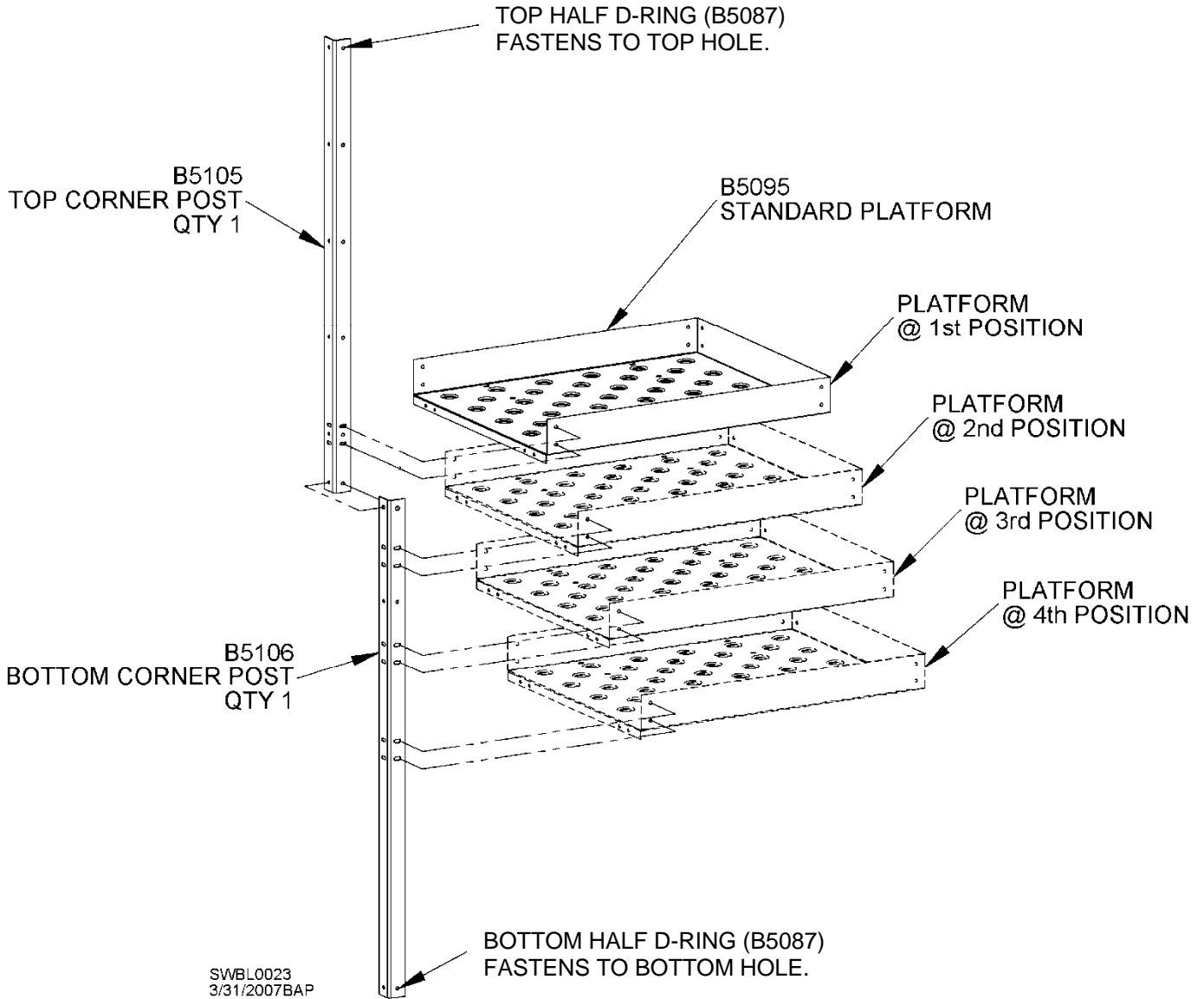

Fig. 13

Eave Platform Cage, 36" Platform

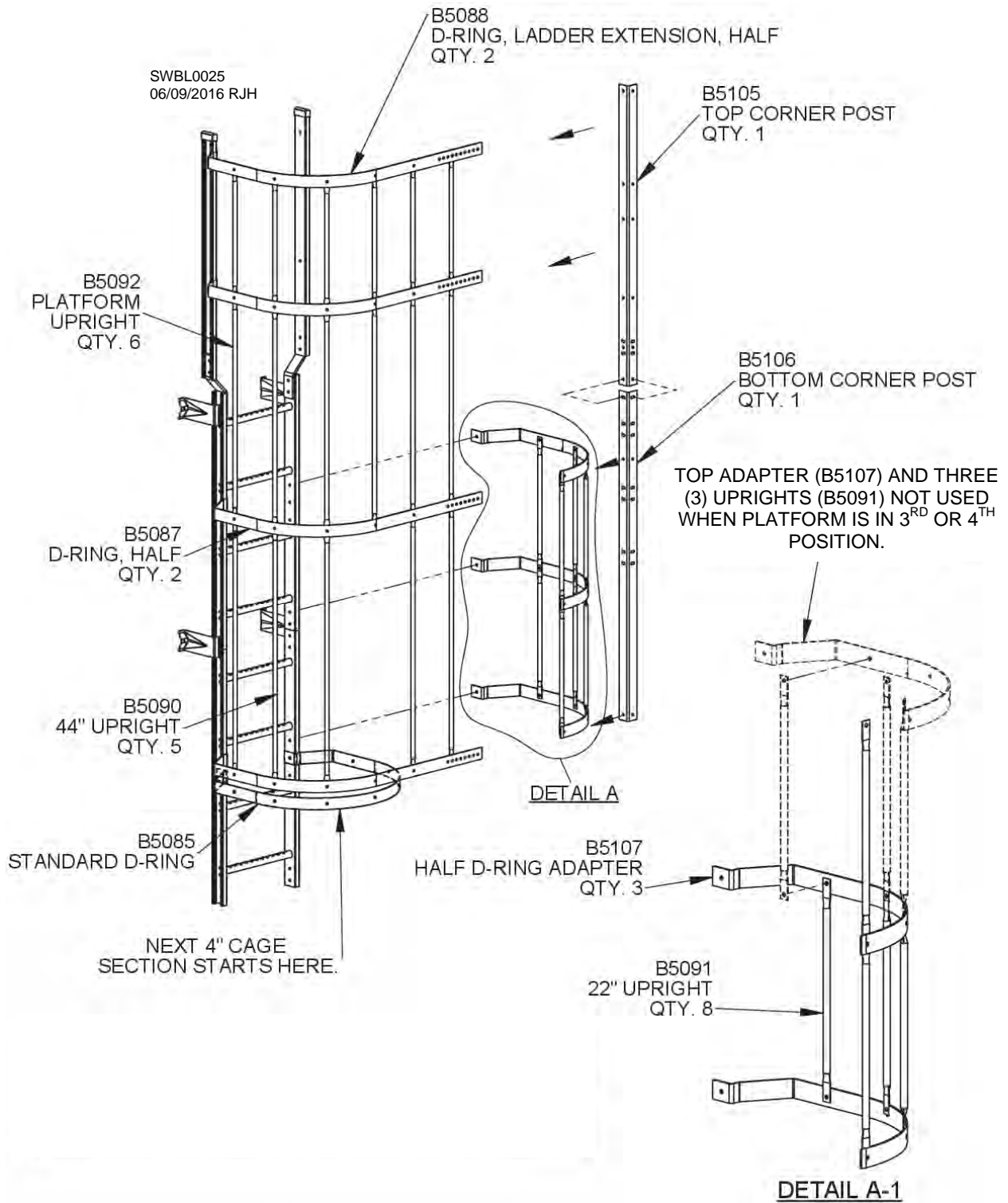
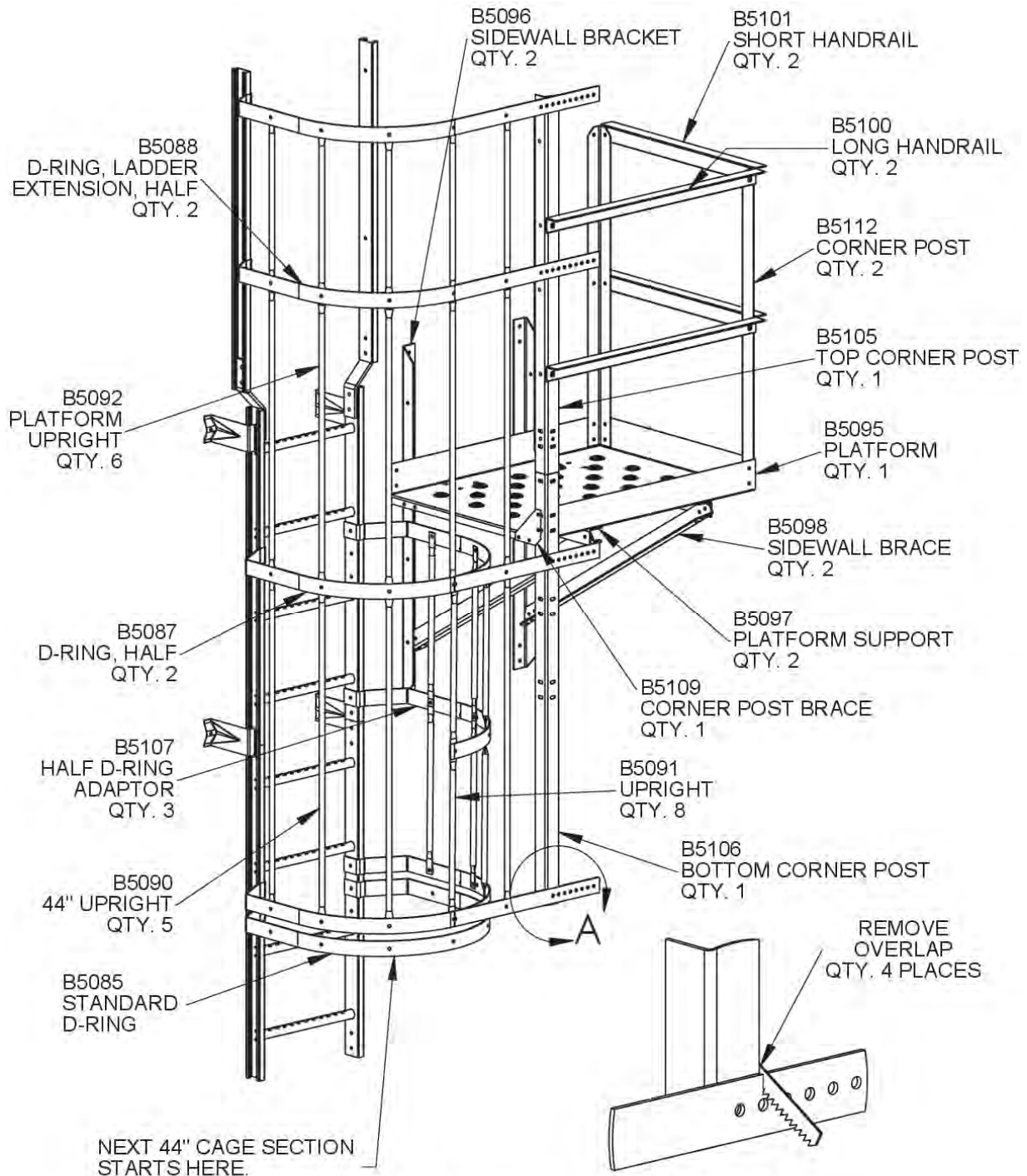

Fig. 14

When attaching cage to platform, half D-rings (B5087 & B5088) must attach to corner posts (B5105 & B5106) as shown in Fig. 14. **NOTE:** If platform is mounted in 1st or 2nd position, attach cage extension as shown in Detail A. If platform is mounted in 3rd or 4th position, top half D-ring adapter (B5107) and three uprights are not used. See Detail A-1. Attach remaining upright to half D-ring B5087.

Eave Platform Cage Assembly, 36" Platform



SWBL0026
5/20/2016 RJH

Fig. 15

Final attachment of cage to extensions and platform is shown in Fig. 15. Platform is shown in 2nd position. All cage and platform assemblies are connected with 3/8" hardware. Remove D-ring overlaps as shown in Detail A to ensure smooth, snag-free edges.

NOTE: Six (6) platform uprights and five (5) 44" uprights are sent with this assembly. Depending on diameter of bin, one upright may be discarded at each location where half D-rings connect to corner post. Be certain that gap is no more than 9".

44" Cages with 22" Flared Bottoms

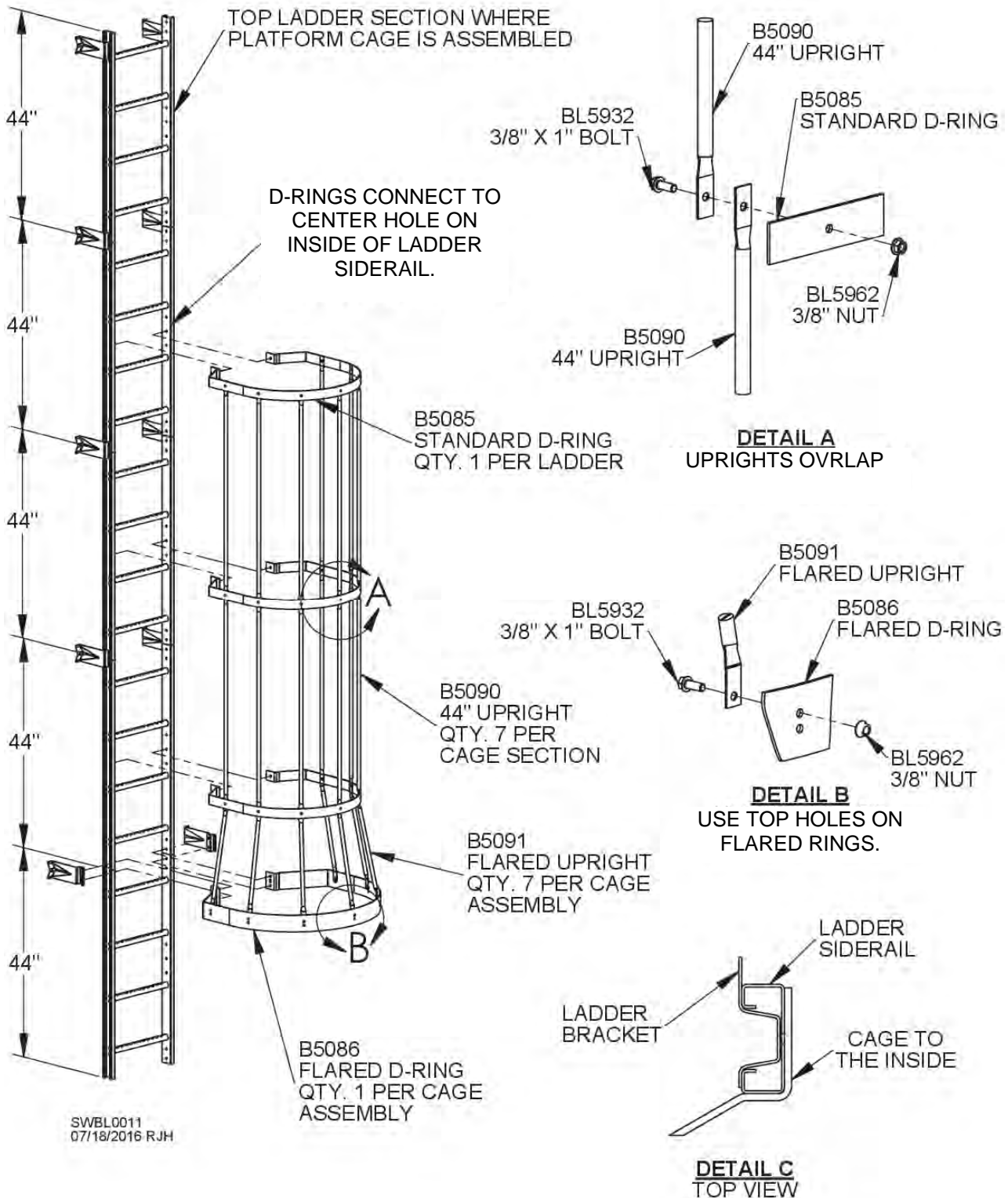

Fig. 16

As bin is built, continue to add appropriate ladder and cage sections. Refer to following pages for specific ladder and cage layouts. Cage sections consist of standard D-rings and seven (7) uprights. Standard D-rings attach to inside of ladder siderails. A flared D-ring (B5086) is always used at bottom of each cage assembly. Top D-ring must be connected to middle of top ladder section. This allows bottom flared D-ring to be at proper height above the next surface (concrete or landing platform). Attach standard D-rings and uprights to ladder sections with 3/8" hardware. See Fig. 16.

Landing Platform Layout, 36" Platform

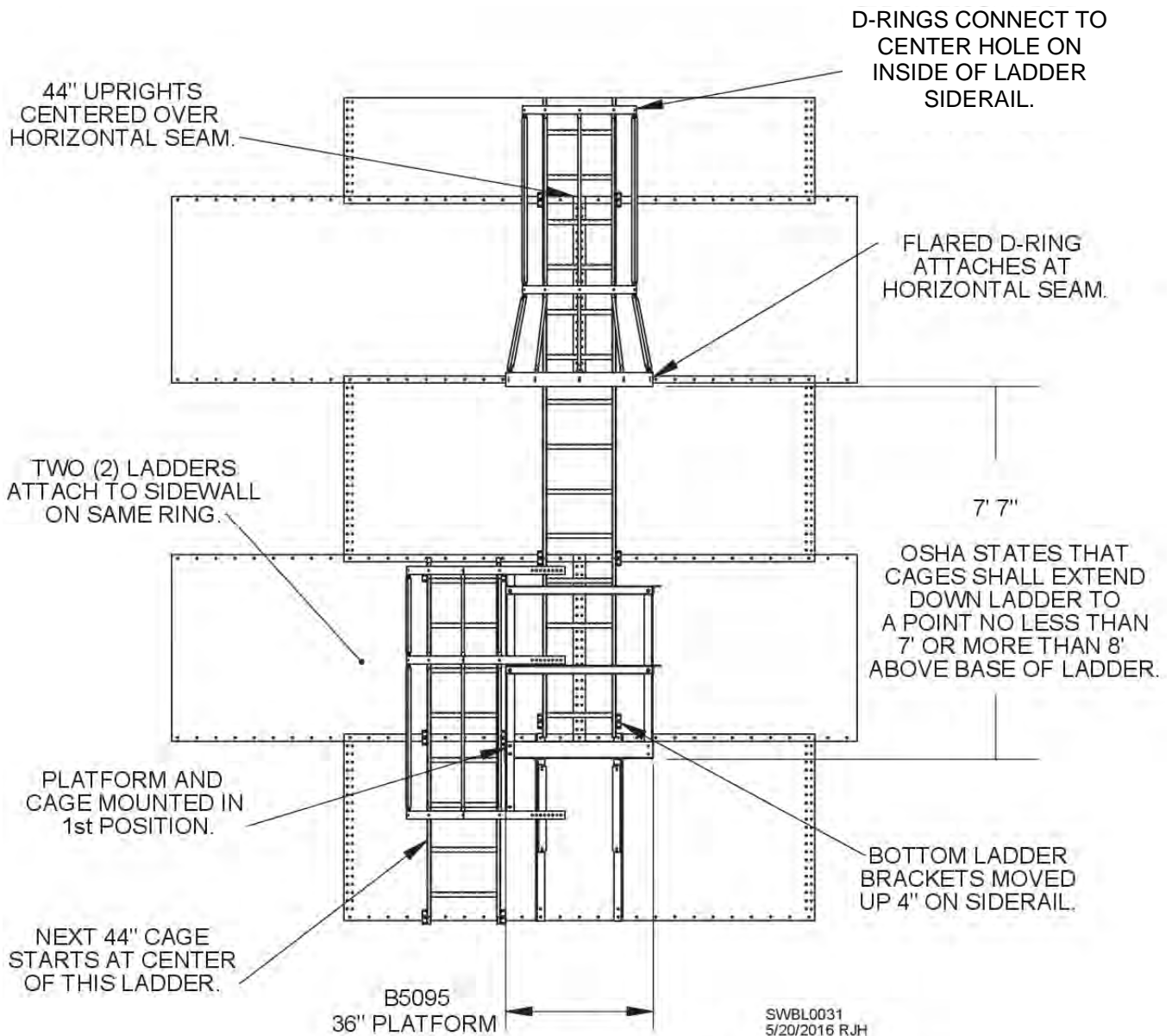

Fig. 17

Fig. 17 shows where flared D-ring should be attached in relation to landing platform. When attached correctly, flared D-ring should be two (2) sidewall rings above landing platform. **Landing platform must be attached to sidewall in 1st position.** This will ensure OSHA standards are met, as well as ease erection of ladder and cages. Two ladders attach to sidewall on same ring at landing platform location. Remember that at top and bottom of each ladder assembly, sidewall brackets need to be moved either up or down 4" to avoid interference with roof sheets, landing platform brackets, concrete and ladder caps.

Landing Platform with Cage, 36" Platform

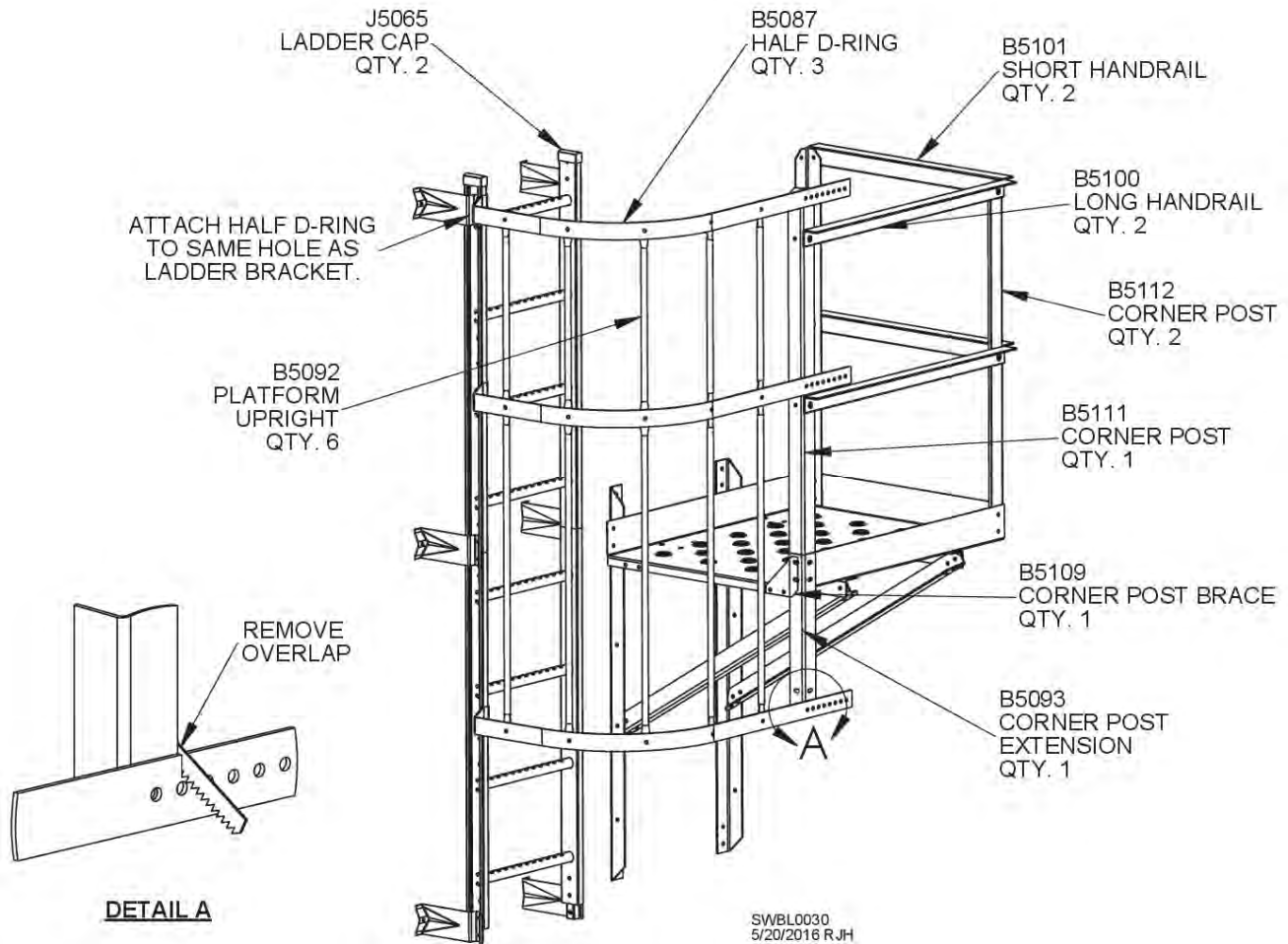

Fig. 18

Attach 36" landing platform to sidewall directly under upper ladder (not shown). **Mount landing platform in 1st position.** See Fig. 17. Attach 44" ladder section to sidewall ring above platform. Fasten corner post extension, (B5093) to bottom of open-faced corner post B5111 as shown in Fig. 18. Note that corner post B5111 is slightly longer than B5112 posts. Placement is critical.

Attach half D-rings to inside of ladder siderail and fasten them to corner post B5111 and corner post extension, B5093. Connect safety cage uprights to half D-rings with 3/8" hardware and tighten. Slide ladder caps over siderails of top ladder section. See Fig. 18. Also, remove half D-ring overlaps as shown in Detail A to ensure smooth, snag-free edges.

54" Platform Locations

Fig. 19 shows both positions where platform can be located. **NOTE:** Each location is at same level as a ladder rung in first ring. For both positions, 44" sidewall brackets mount to sidewall at horizontal seams and at middle of sidewall sheet. Field-drilling is required.

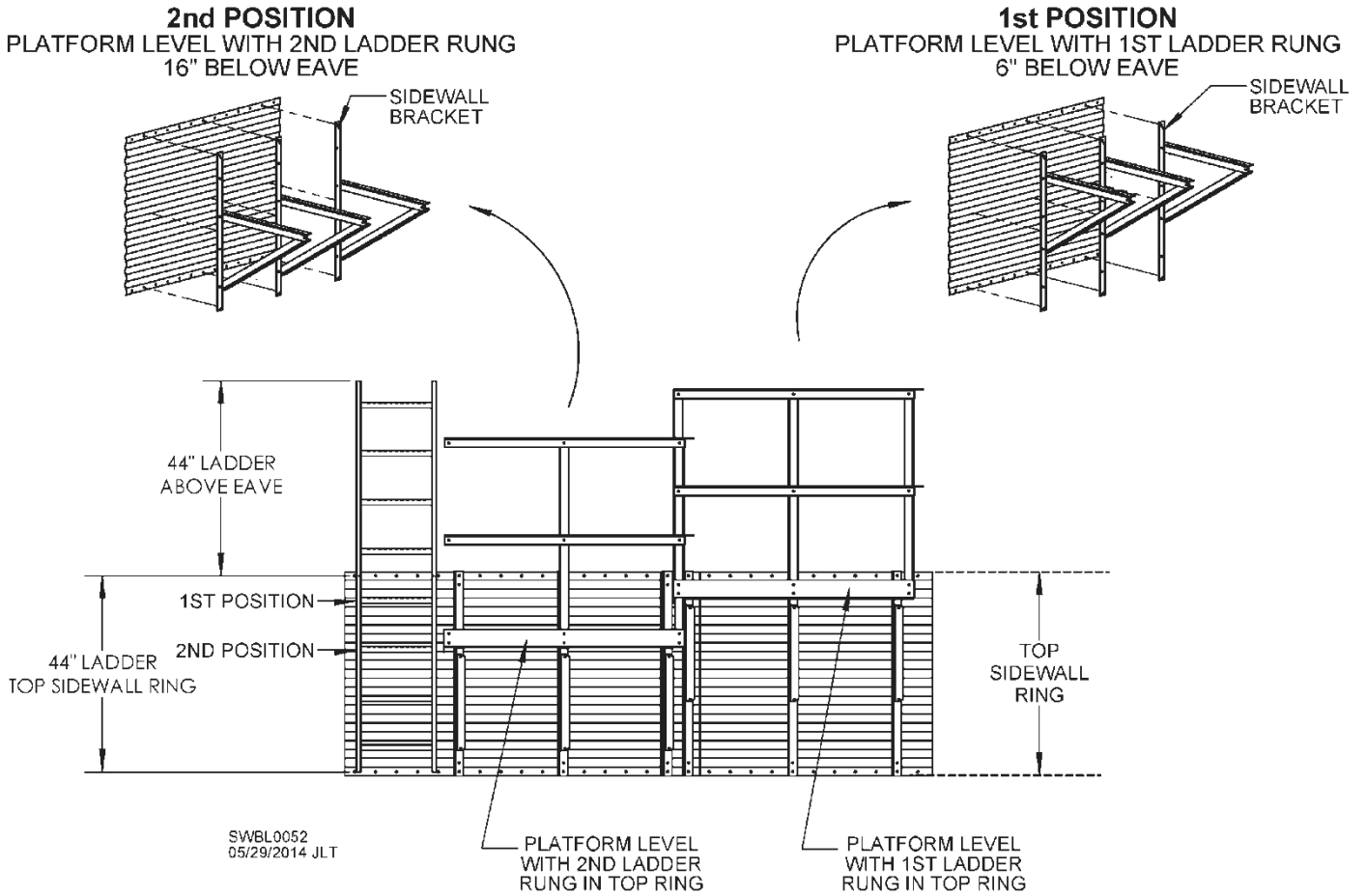
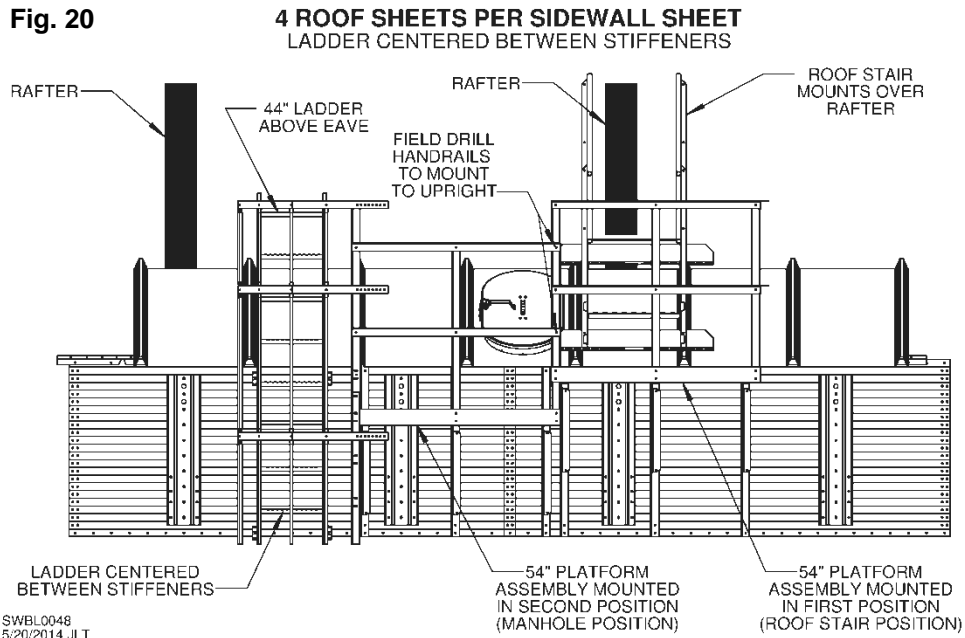
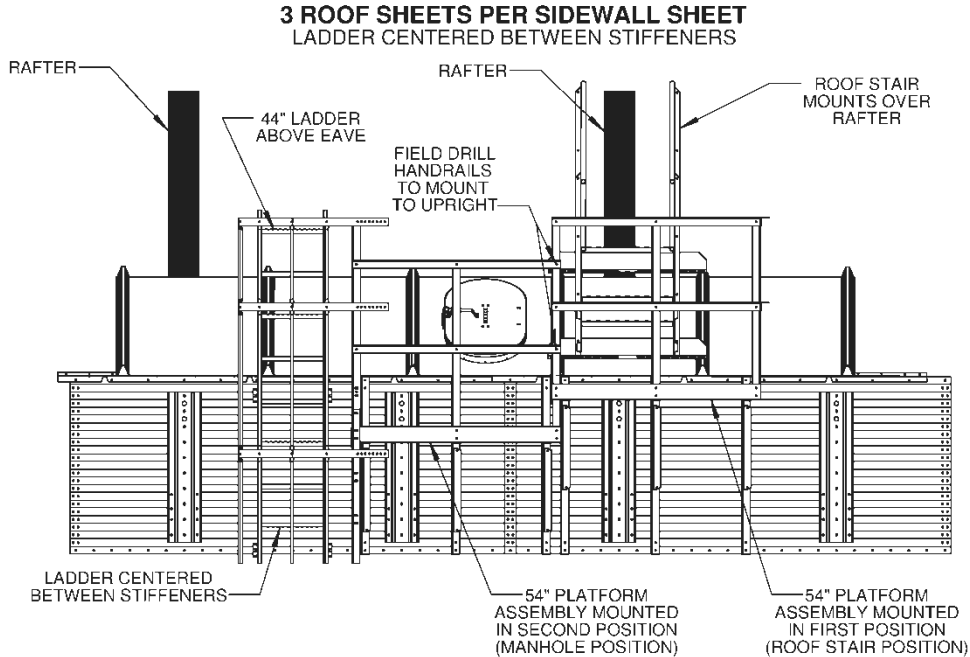

Fig. 19

54" Platform Starting Location

Location of ladder is a critical factor in constructing a grain bin. Careful thought must be given to position of sidewall and roof ladders in relationship to overall layout of site and auxiliary equipment. Location of roof ladder and manhole during bin construction will establish location of sidewall ladder. Sidewall ladder and eave platform must be in line with roof ladder and manhole. Fig. 20 shows ladder and eave platform starting locations when either 3 or 4 roof sheets attach per sidewall sheet.

IMPORTANT: When attaching ladder and safety cages to a stiffened bin, locate ladder between two (2) stiffeners. When constructing bin with raftered substructure, be certain manhole is not aligned over a rafter. Suggestion: Locate roof ladder on roof sheet to right of primary rafter. Manhole can then be placed on sheet to right of roof ladder. This ensures that eave platform will be centered over a stiffener. Platforms are designed to ensure that when additional ladder columns are offset, they are not centered over a stiffener.



Attaching Ladder & Platforms to Bin with 3 Stiffeners per Sidewall Sheet

See Fig. 21 for positioning and attachment of ladder between stiffeners on bin with three stiffeners per sidewall sheet. Fig. 21 also shows positioning and attachment of manhole platform, roof stairs platform and 54" landing platform on bin with three stiffeners per sidewall sheet.

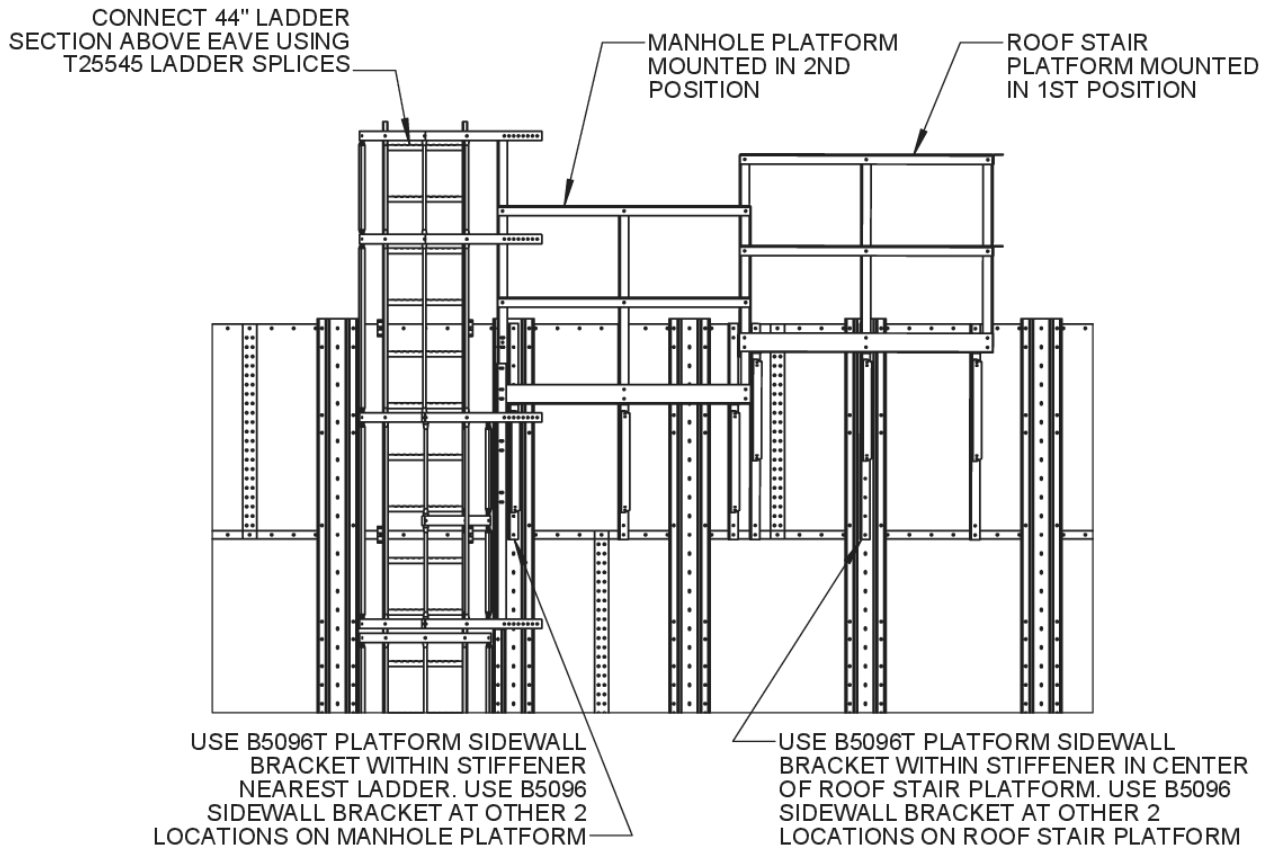
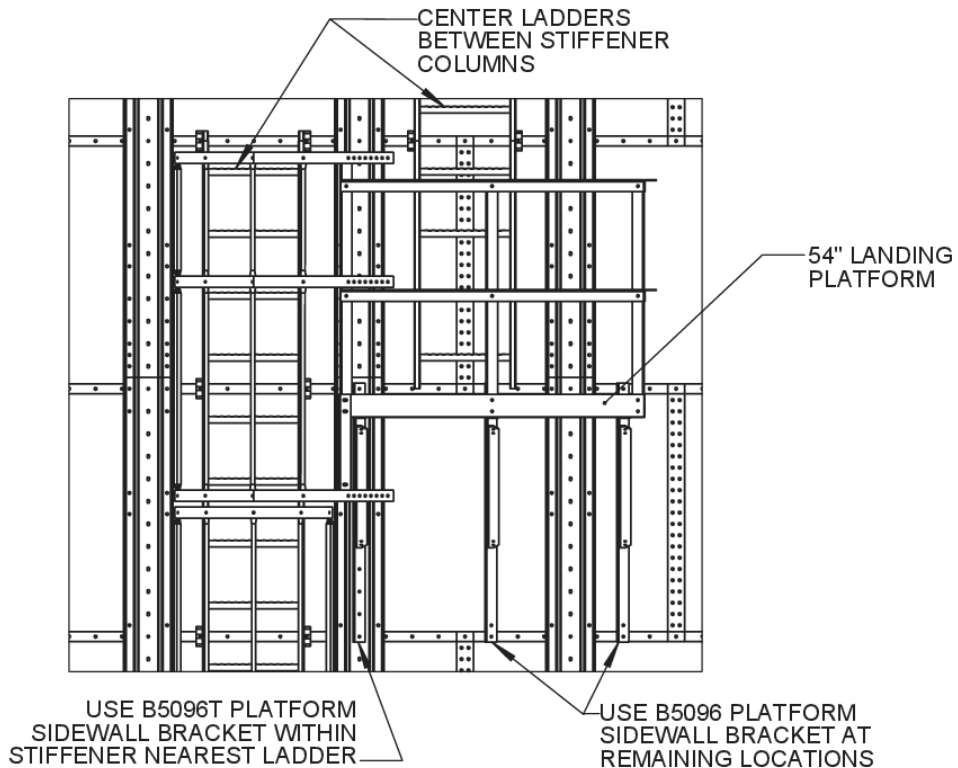

Fig. 21



SWBL0057
03/03/2015; JLT

54" Platform Assembly

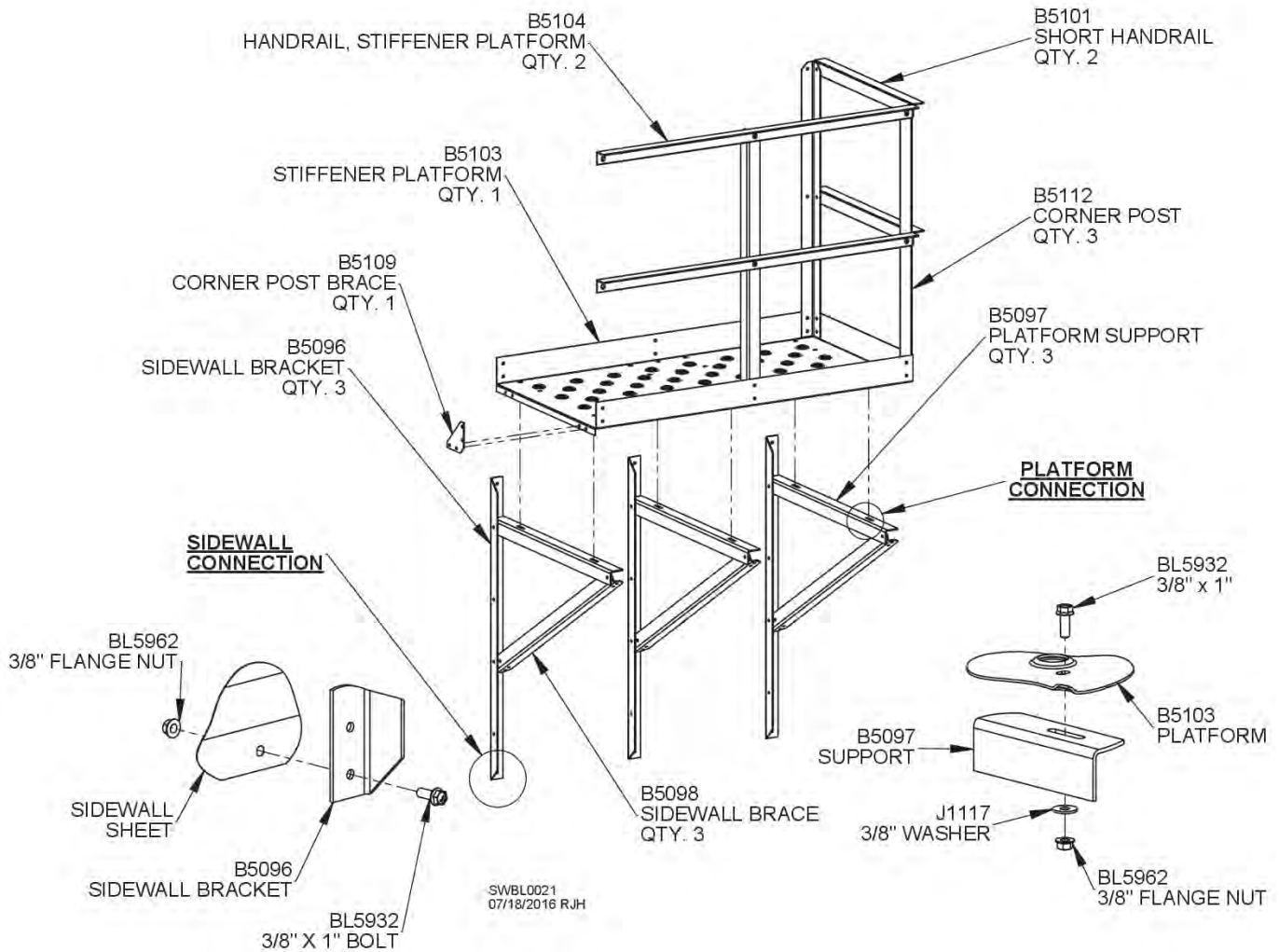

Fig. 22

Entire platform assembly is constructed with 3/8" hardware. Begin by attaching sidewall brackets (B5096) to sidewall. Some holes may need to be field-drilled in sidewall depending on which position was chosen for platform. Attach platform supports (B5097) and brace angles (B5098) to sidewall brackets as shown in Fig. 22. **NOTE:** Leave all bolts loose until assembly is complete.

Attach platform (B5120) to platform supports and fasten corner posts (B5112) to 4" toeboard. Fasten long and short platform handrails to corner posts. See Fig. 22. Only three (3) corner posts are shown. Corner post brace (B5109) and post that it braces will attach later. Platform and handrails will attach later to extensions that will be connected to cage.

Top & Bottom Corner Posts, 54" Platform

Fig. 23 shows both locations where platform can be positioned. Top and bottom corner posts will not be moved vertically. Only the platform assembly itself will be able to move up or down on corner posts. **NOTE:** Top half D-ring fastens to top hole in top corner post and bottom half D-ring fastens to bottom hole of bottom corner post. See Fig. 23.

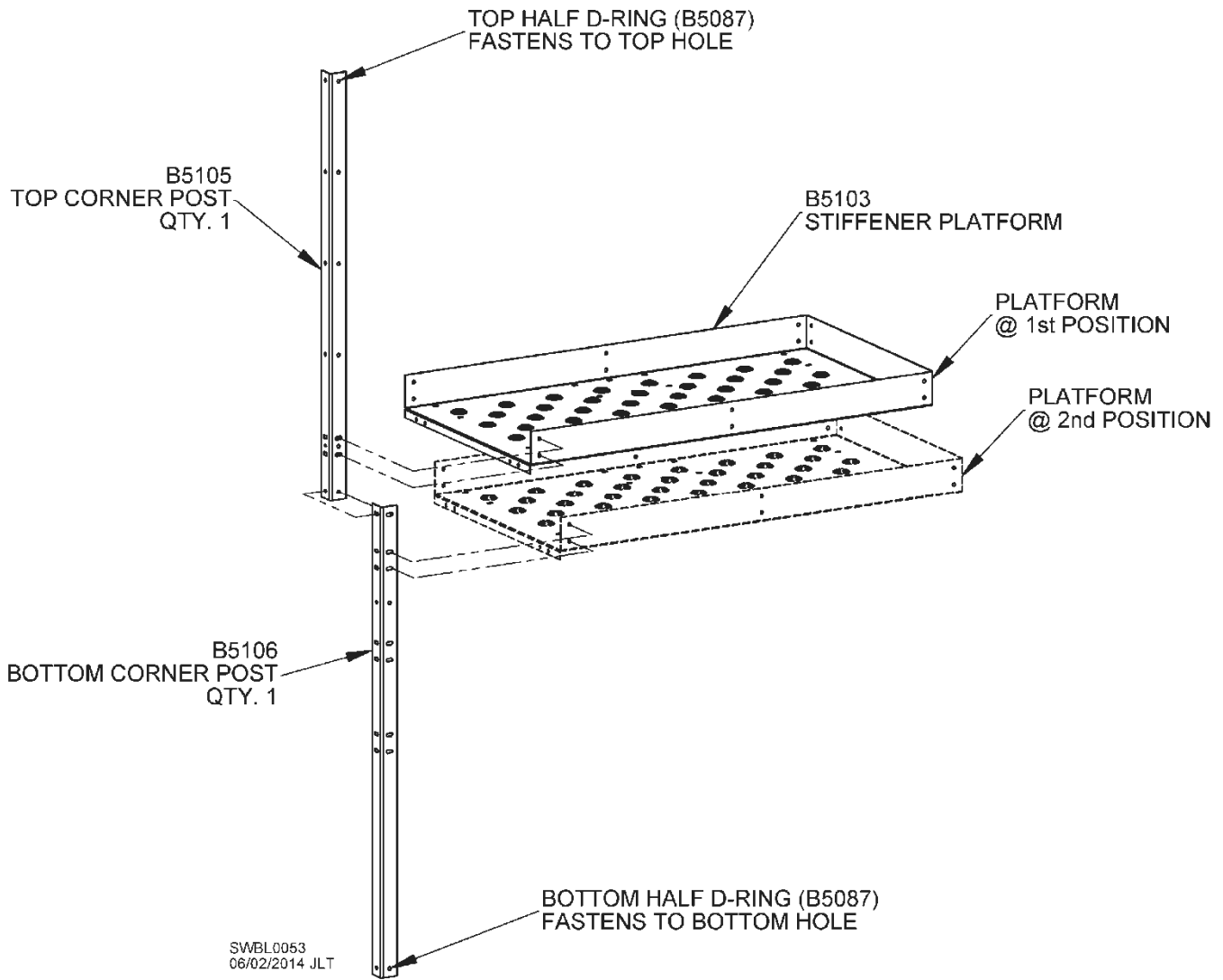

Fig. 23

Eave Platform Cage, 54" Platform

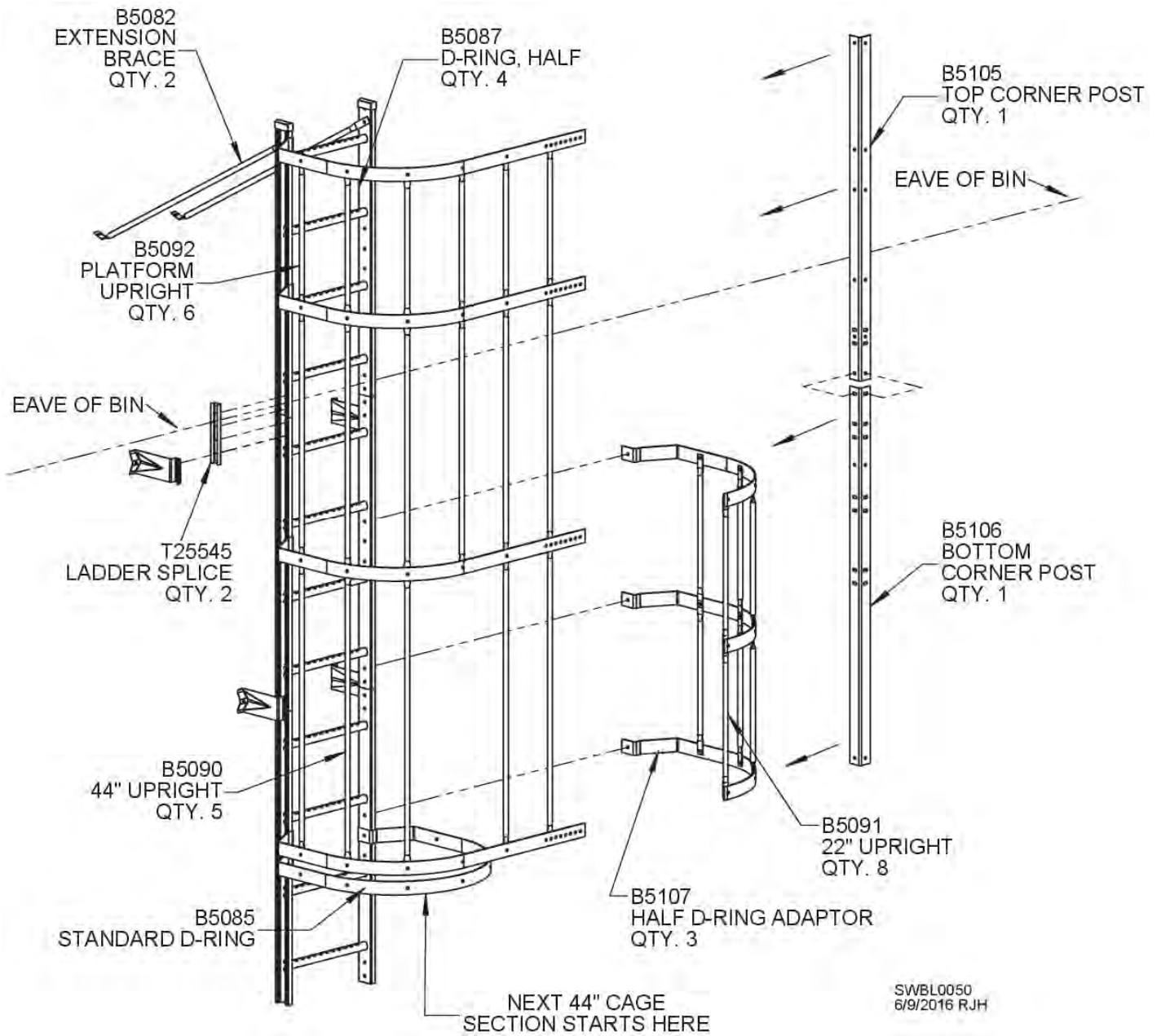

Fig. 24

When attaching cage to platform, half D-rings (B5087) must attach to top and bottom corner posts (B5105 & B5106) as shown in Fig. 24. Attach half D-ring adaptors (B5107) to ladder as shown.

Eave Platform Cage Assembly, 54" Platform

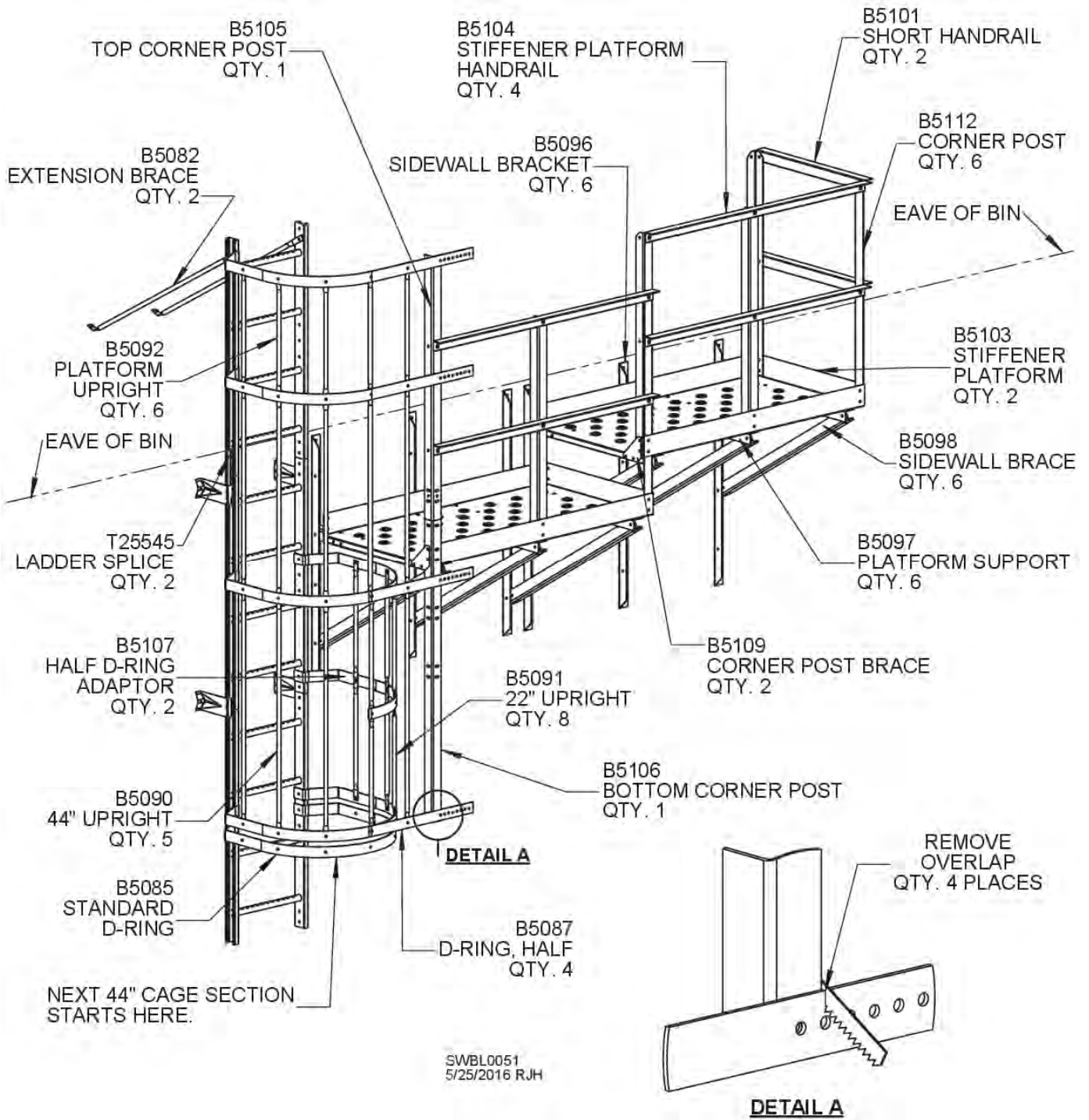

Fig. 25

Final attachment of cage to platform is shown in Fig 25. Manhole platform is shown in 2nd position. Roof stair platform (also known as stiffener platform) is shown in 1st position. All cage and platform assemblies are connected with 3/8" hardware. Remove D-ring overlaps as shown in Detail A to ensure smooth, snag-free edges.

NOTE: Six (6) platform uprights and five (5) 44" uprights are sent with this assembly. Depending on diameter of bin, one upright may be discarded at each location where a half D-ring connects to a corner post. Be certain gap is no more than 9".

44" Cages with 22" Flared Bottoms

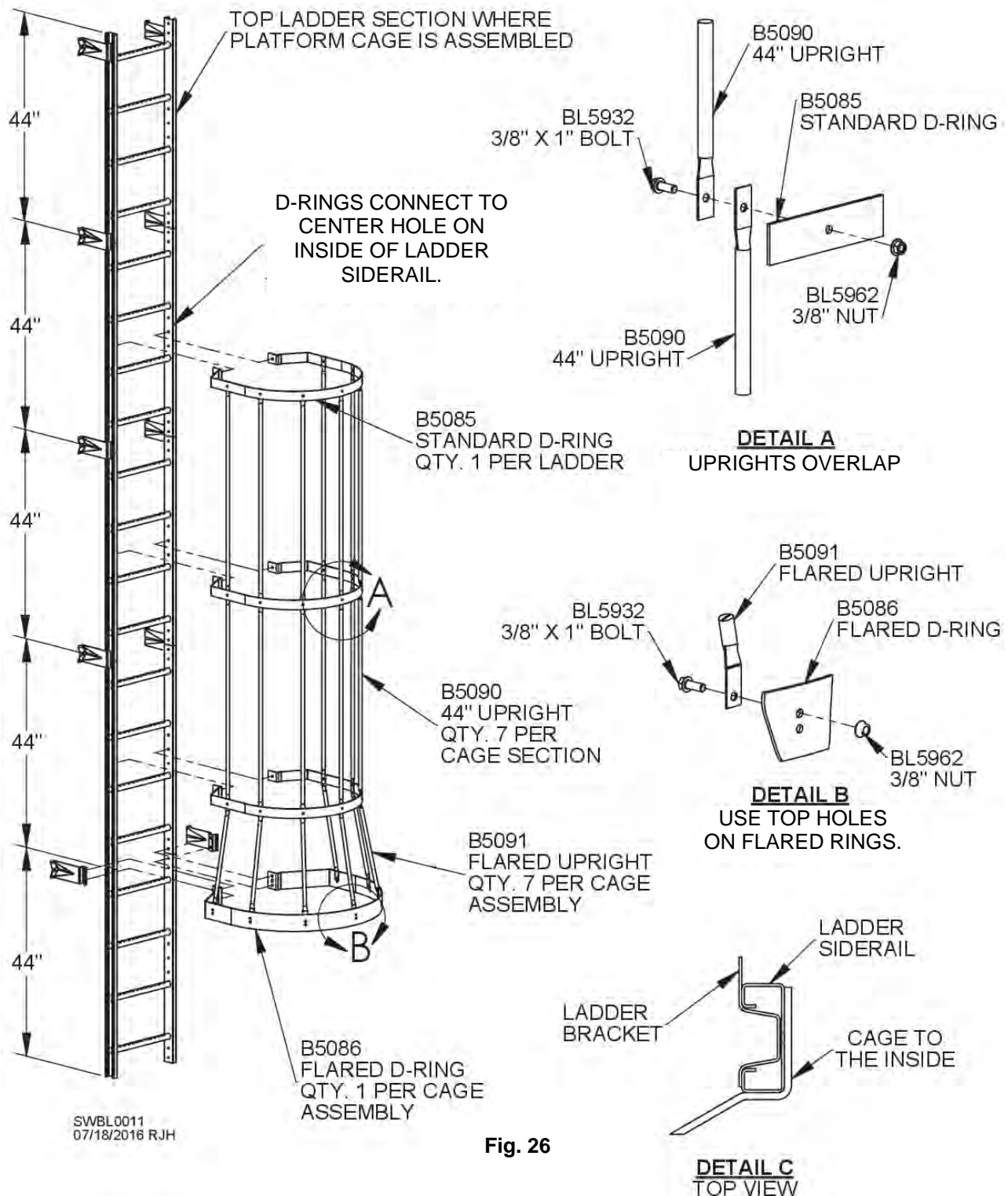

Fig. 26

As bin is built, continue to add appropriate ladder and cage sections. Refer to following pages for specific ladder and cage layouts. Cage sections consist of standard D-rings and seven (7) uprights. Standard D-rings attach to inside of ladder siderails. A flared D-ring (B5086) is always used at bottom of each cage assembly. Top D-ring must be connected to middle of top ladder section. This allows bottom flared D-ring to be at proper height above the next surface (concrete or landing platform). Attach standard D-rings and uprights to ladder sections with 3/8" hardware. See Fig. 26.

Landing Platform Layout, 54" Platform

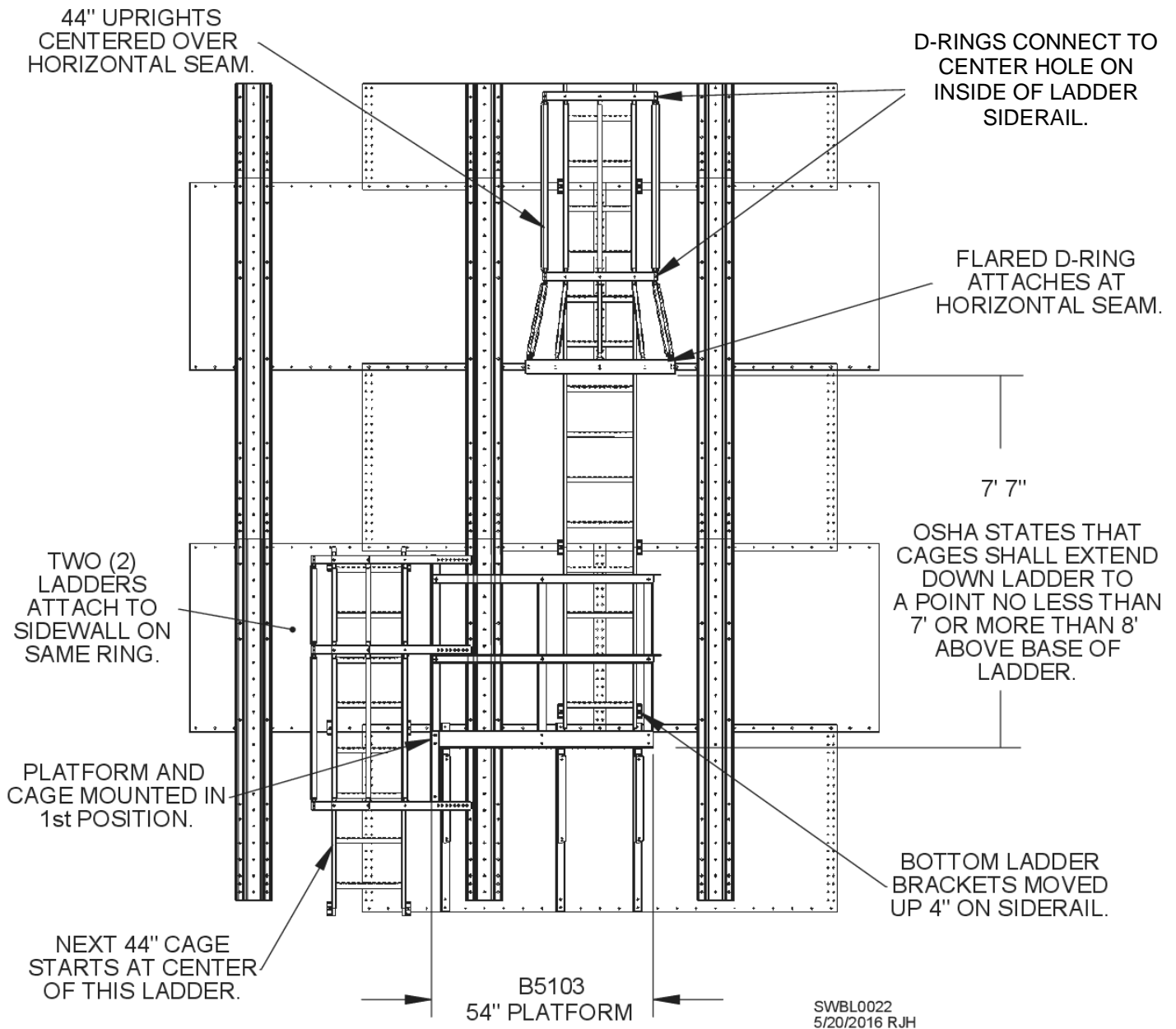

Fig. 27

Fig. 27 shows where flared D-ring should be attached in relation to landing platform. When attached correctly, flared D-ring should be two (2) sidewall rings above landing platform. **Landing platform must be attached to sidewall in 1st position.** This will ensure OSHA standards are met, as well as ease erection of ladder and cages. Two ladders attach to sidewall on same ring at landing platform location. Remember that at top and bottom of each ladder assembly, sidewall brackets need to be moved either up or down 4" to avoid interference with roof sheets, landing platform brackets, concrete and ladder caps.

To ensure that additional ladder columns will be centered between two stiffeners, attach landing platform to sidewall as shown in Fig. 27. Top ladder column should have already been centered between two stiffeners.

Landing Platform with Cage, 54" Platform

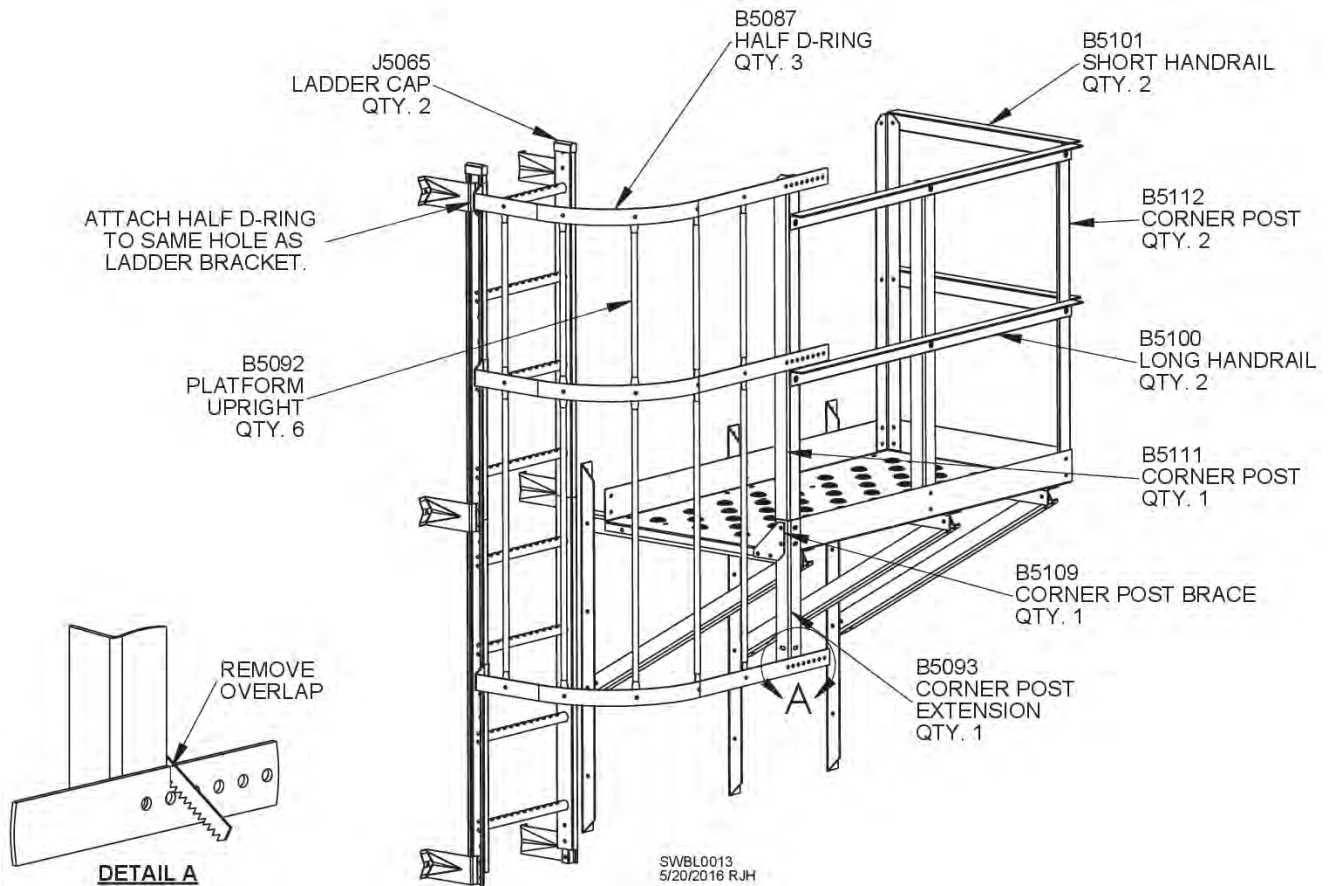
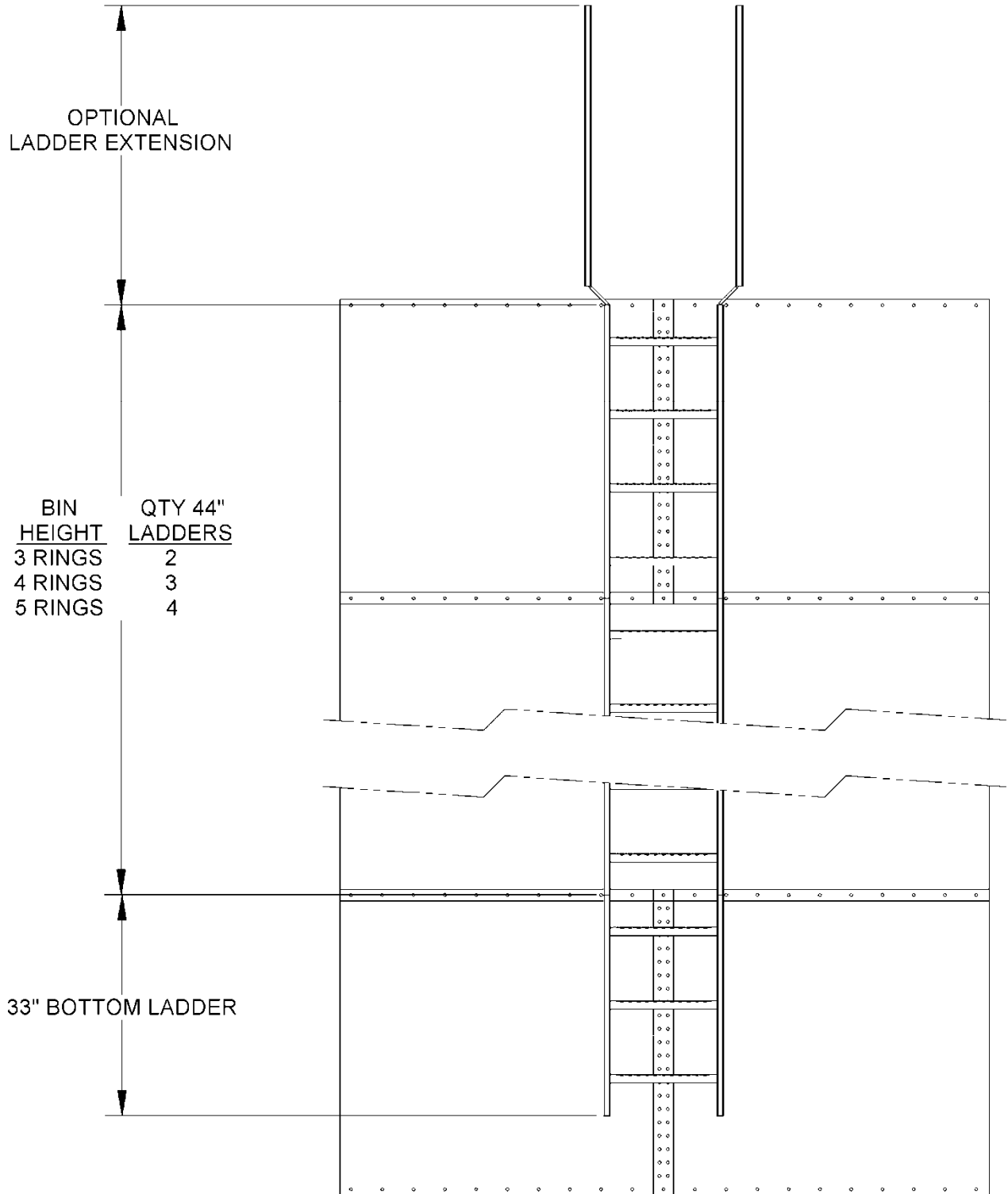

Fig. 28

Attach 54" landing platform to sidewall directly under upper ladder (not shown). **Mount landing platform in 1st position.** See Fig. 27. Attach 44" ladder section to sidewall ring above platform, centered between two stiffeners. Fasten corner post extension, B5093, to bottom of open-faced corner post B5111 as shown in Fig. 28. Note that corner post B5111 is slightly longer than B5112 posts. Placement is critical.

Attach half D-rings to inside of ladder siderail and fasten them to corner post B5111 and corner post extension, B5093. Connect safety cage uprights to half D-rings with 3/8" hardware and tighten. Slide ladder caps over siderails of top ladder section. See Fig. 28. Also, remove half D-ring overlaps as shown in Detail A to ensure smooth, snag-free edges.

Ladder Layout, 3-Ring to 5-Ring Bin



SWBL0037
7/11/2007KJZ

Fig. 29

Ladder & Cage Layout, 6-Ring to 9-Ring Bin

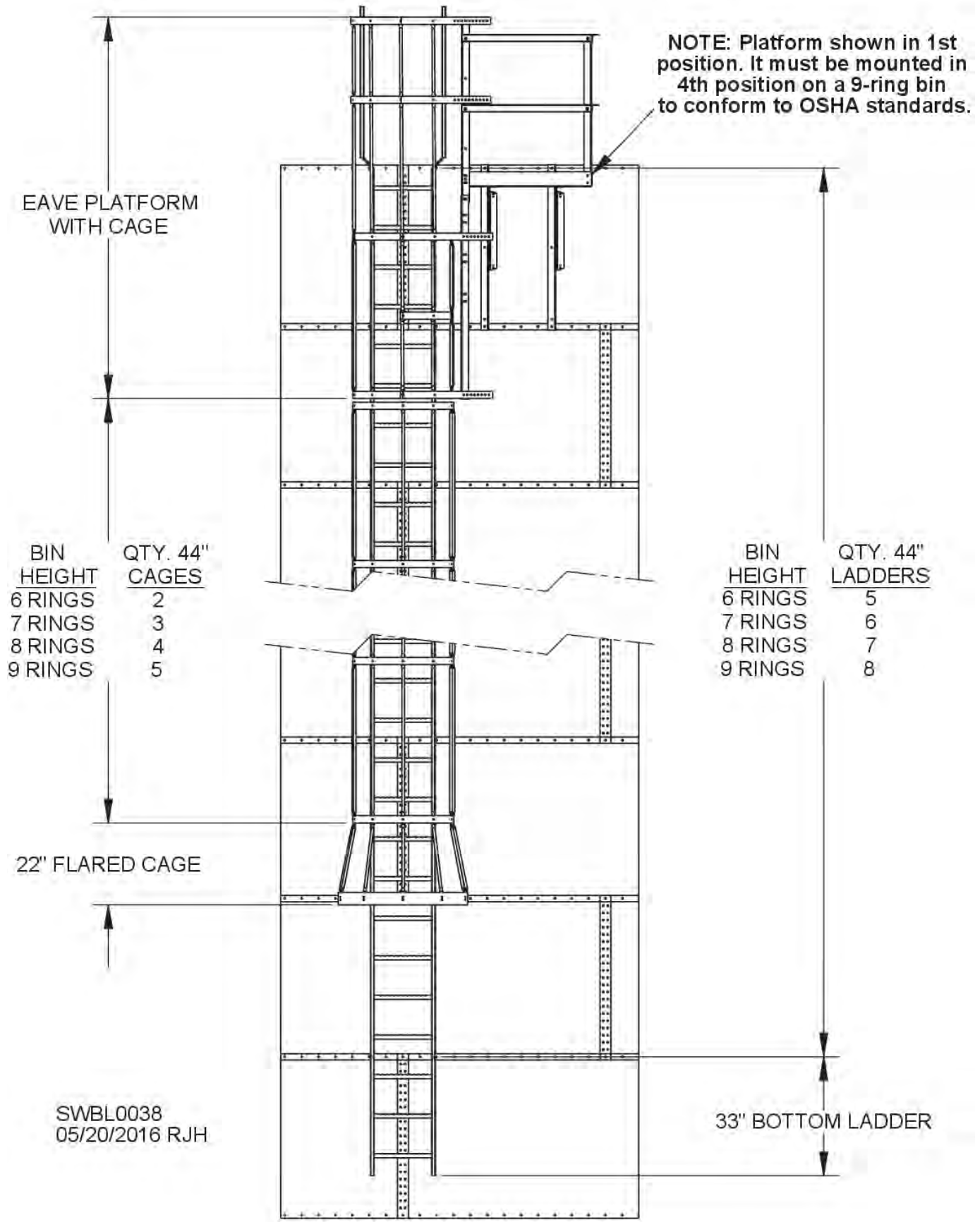

Fig. 30

Ladder & Cage Layout, 9-Ring to 16-Ring Bin

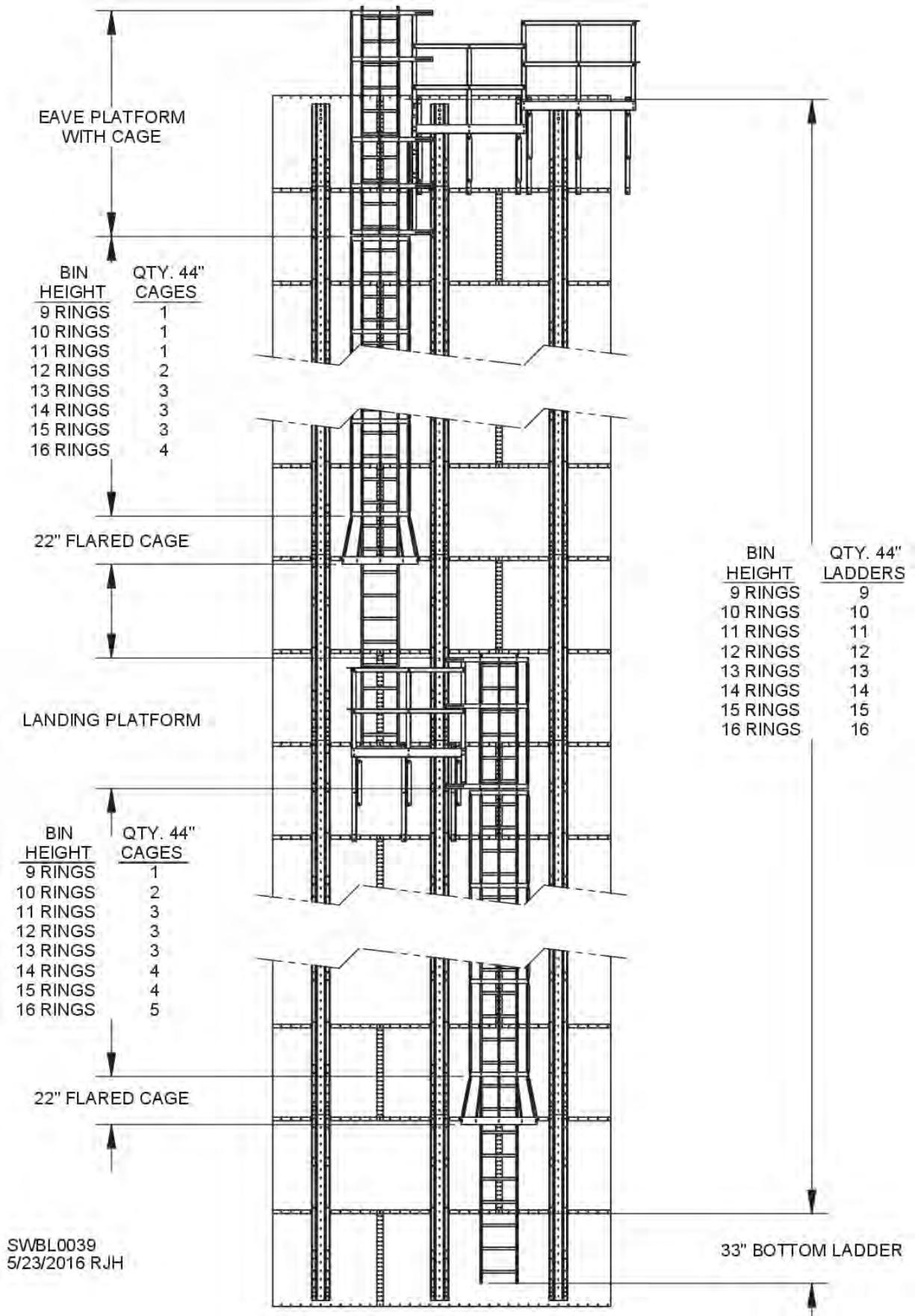

Fig. 31

Ladder & Cage Layout, 17-Ring to 24-Ring Bin

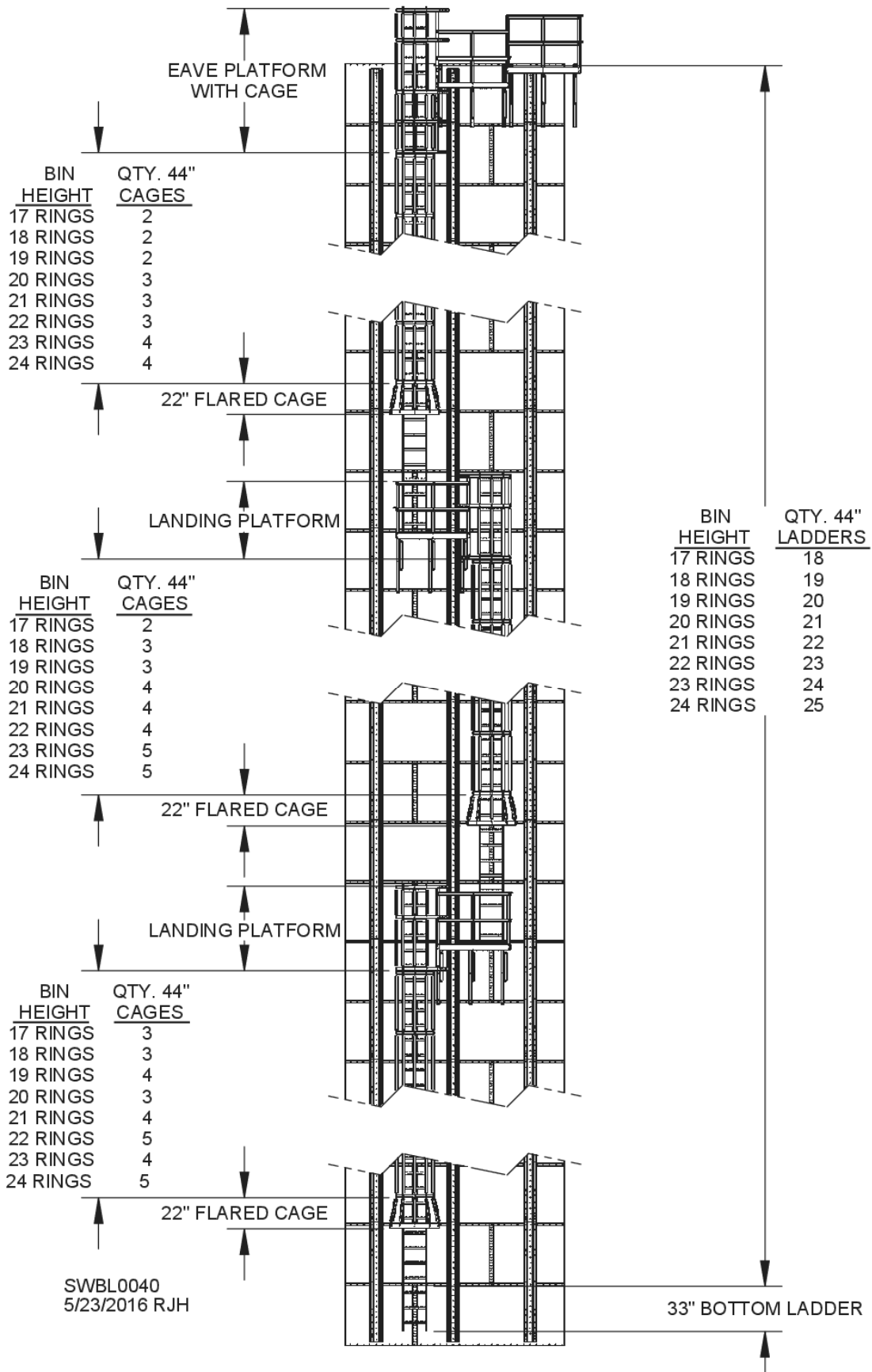

Fig. 32

Ladder & Cage Layout, 25-Ring to 30-Ring Bin

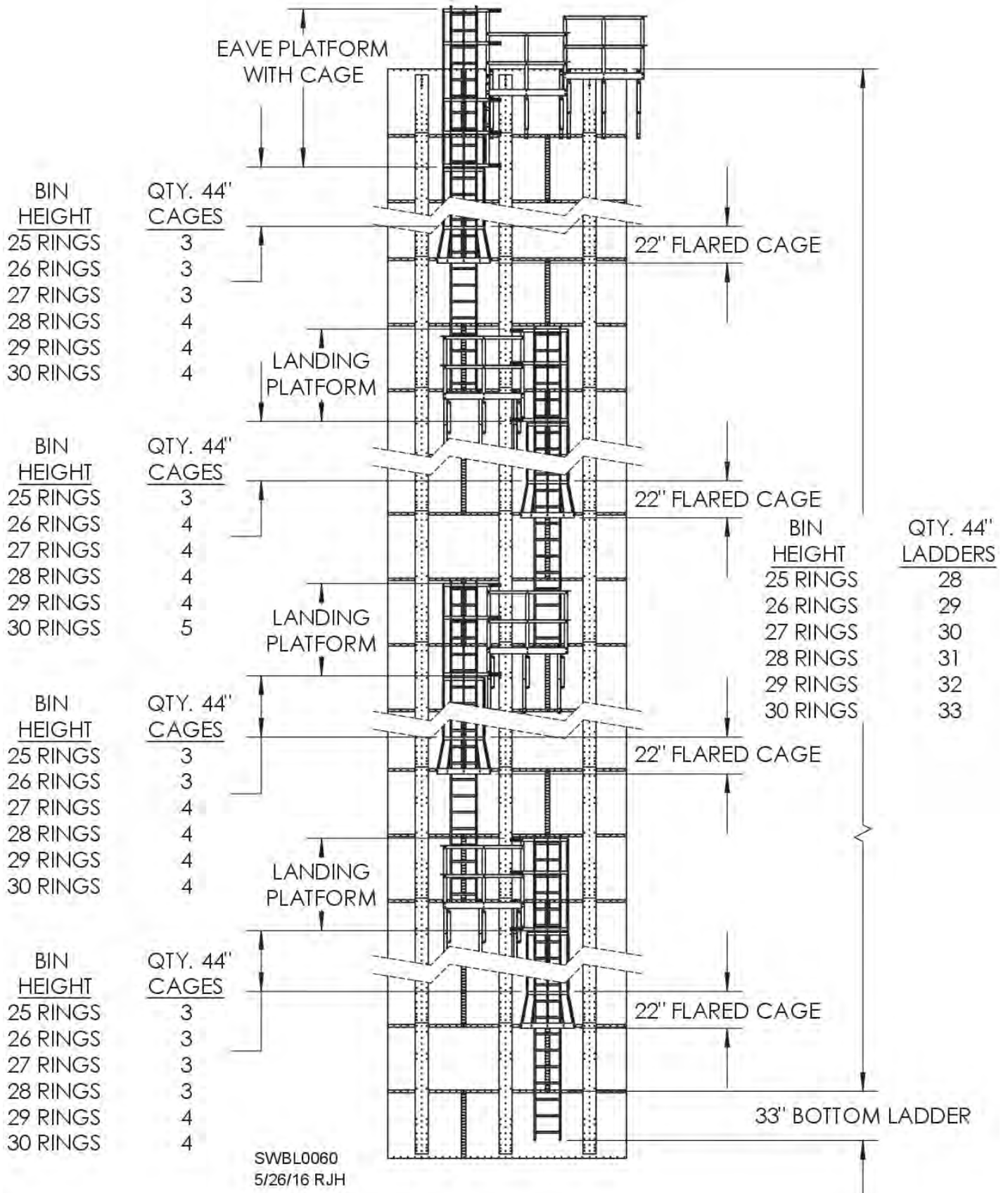
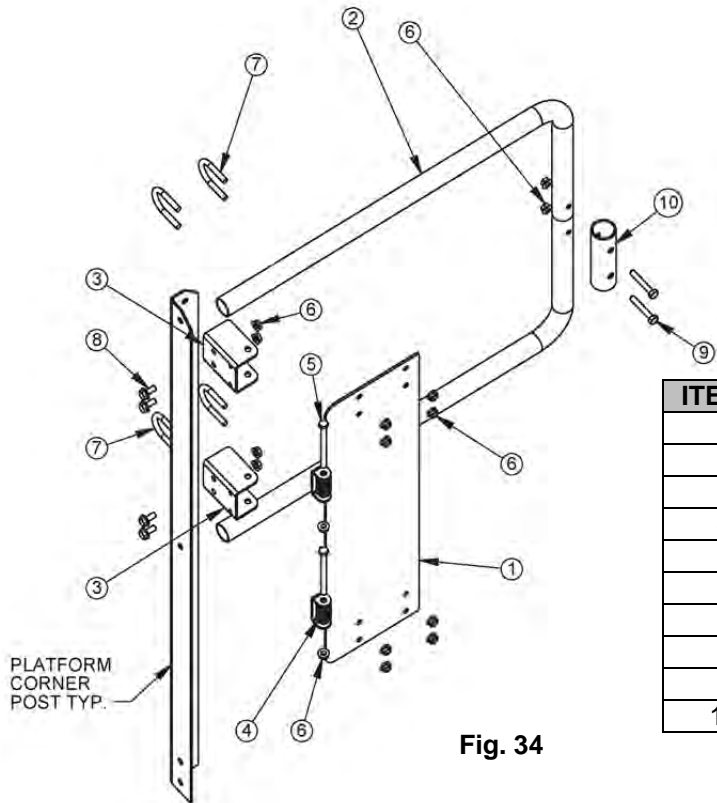

Fig. 33

Ladder Platform Swing Gate

Use drawings and parts list below to assemble ladder platform swing gate.



| ITEM # | DESCRIPTION | QTY. | COMP. # |
|--------|-----------------------------------|------|---------|
| 1 | Hinge plate | 1 | BSG0003 |
| 2 | Rail tubing | 2 | BSG0001 |
| 3 | Hinge bracket | 2 | BSG0004 |
| 4 | Torsion spring | 2 | J23832 |
| 5 | Screw, 5/16 – 18 x 4" | 2 | J0598 |
| 6 | Flange nut, 5/16" | 16 | B5922 |
| 7 | U-bolt, 5/16 – 18 x 2", 1-1/4" ID | 4 | J0556 |
| 8 | Screw, 5/16 – 18 x 3/4" | 4 | J0522 |
| 9 | Screw, 5/16 – 18 x 2" | 2 | J0584 |
| 10 | Rail splice | 1 | BSR1015 |

Fig. 34

Assemble swing gate and attach to hinge plate using U-bolts (J0556) and 5/16" flange nuts (B5922).

Field-drill holes in upright for attachment of hinge brackets (BSG0004). Top of upper bracket should be 4-1/2" from top of handrail as shown in Fig. 35.

Fasten hinge brackets to upright with 5/16 – 18 x 3/4" screws (J0522) and 5/16" flange nuts (B5922).

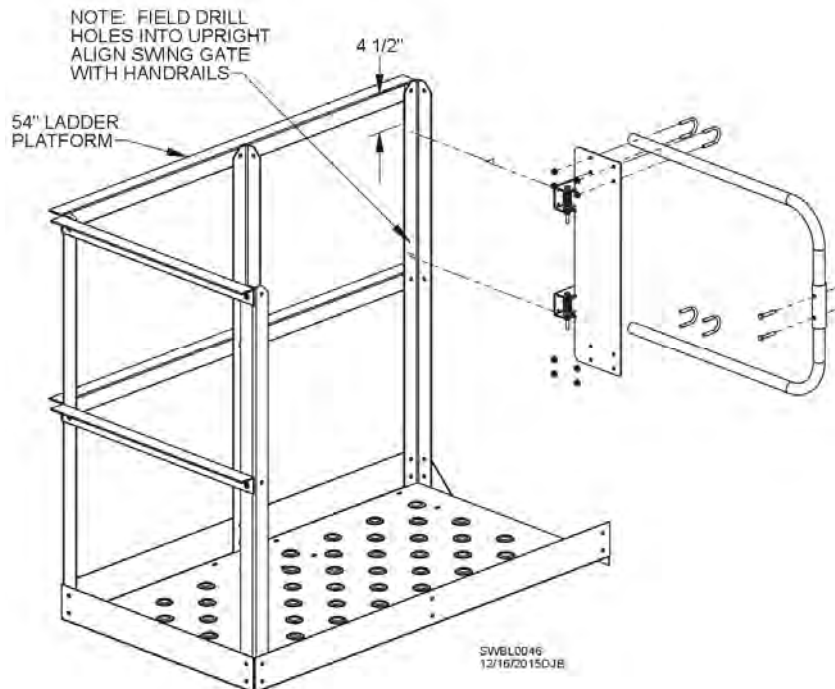

Fig. 35

| | |
|---------------------------------------------------------------------------------------------------------------------------------------|----------------------------------------------------------------------------------------------------------------------------------------------------|
| <p>GREENE GALVANIZED STAIRS www.greenebinstairs.com</p> | <p>GREENE Welding & Hdw., Inc. 41774 Main St. Box 191 • East Lynn, IL 60932 217-375-4244 • Fax: 217-375-4245</p> |
|---------------------------------------------------------------------------------------------------------------------------------------|----------------------------------------------------------------------------------------------------------------------------------------------------|

Sidewall Stair assembly instructions



Side Wall Stairs Assembly

Before you begin, read these directions completely and carefully. Make sure you have all the necessary packages for installation (see chart 1)

CHART 1

The location of the platform is determined by using different packages for the top 2 rings of bin. Use the same number of sections as bin rings below the top 2 rings.

| Ht of rings | 5 1/2" below eave | 16" below eave | 26 1/2" below eave | Intermediate platform |
|-------------|----------------------------------------------------------------|----------------------------------------------------------------|----------------------------------------------------------------------------------------|------------------------------------------------------|
| 44" | 1-14400 44" section 1-13200 32" section 1-35000 platform | 1-14400 44" section 1-12100 21" section 1-35000 platform | 1-13200 32" section 1-12100 21" section 1-35000 platform 1-40000 booster step | 1-13200 32" section 1-36000 intermediate platform |
| 32" | 1-13200 32" section 1-12100 21" section 1-35000 platform | 1-14400 44" section 1-35000 platform | 1-13200 32" section 1-35000 platform 1-40000 booster step | 1-12100 21" section 1-36000 intermediate platform |

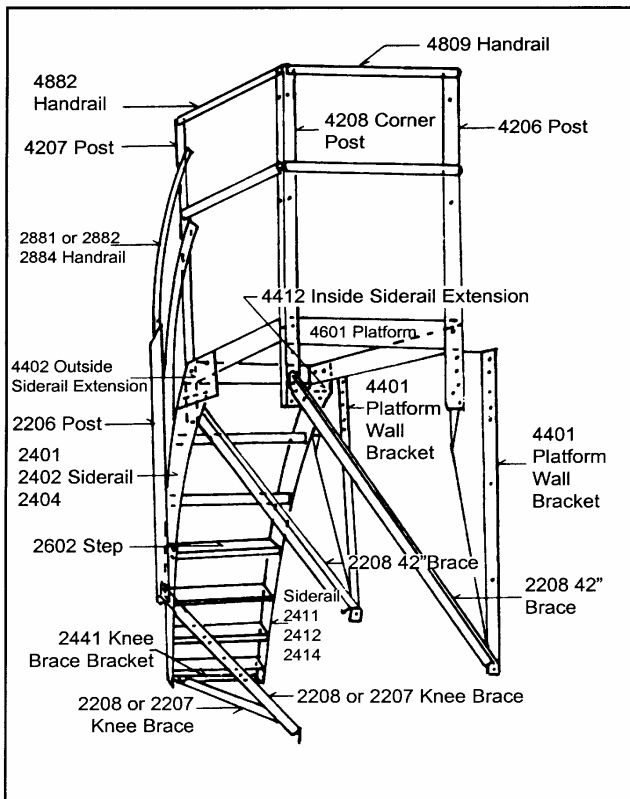

| | 21" Stair Section 12000 | 32" Stair Section 13200 | 44" Stair Section 14400 | Platform 35000 | Intermediate Platform 36000 | Twin Platform 37000 | Ladder Platform 38000 | Booster Step 40000 | |
|---|-------------------------|-------------------------|-------------------------|----------------|-----------------------------|---------------------|-----------------------|--------------------|-------------------------------------------|
| 1 | 1 | 1 | 1 | 1 | | | | | 2205 Wall bracket |
| 1 | 1 | 1 | | | | | | | 2206 Baluster post 54" |
| 1 | 1 | | | | | | | | 2207 Knee brace 32" section 34 3/4" |
| | | 1 | 2 | 2 | 2 | 2 | | | 2208 Knee brace 44" section 42 1/2" |
| 1 | 1 | | | | | | | | 2401 Siderail outside 21" section 38" |
| | | 1 | | | | | | | 2402 Siderail outside 32" section 53" |
| 1 | | | | | | | | | 2404 Siderail outside 44" section 70 1/4" |
| | | | | | | | | | 2411 Siderail inside 21" section 35" |
| | 1 | | | | | | | | 2412 Siderail inside 32" section 50" |
| | | 1 | | | | | | | 2414 Siderail inside 44" section 65" |
| 2 | 3 | 4 | 1 | | | | | | 2441 Bottom knee brace bracket |
| | | | | | | | | | 2602 Step 9 x 20" |
| 2 | 2 | | | | | | 1 | | 2802 Booster step 7 x 20" |
| | | | | | | | | | 2881 Handrail 21" section 34" |
| | | | | | | | | | 2882 Handrail 32" section 51" |
| | | | | | | | | | 2884 Handrail 44" section 67 1/2" |
| | | | 1 | 2 | | 1 | | | 4205 Post 9 1/2" |
| | | | 1 | 1 | 2 | 1 | | | 4206 Platform post right 51 1/2" |
| | | | 1 | 1 | 2 | 1 | | | 4207 Platform post left 51 1/2" |
| | | | 1 | | 1 | 1 | | | 4208 Platform corner post 51 1/2" |
| | | | 2 | | 2 | 2 | | | 4401 Platform wall bracket 37" |
| | | | 1 | 2 | | | | | 4402 Outside siderail extension |
| | | | 1 | 2 | | | | | 4412 Inside siderail extension |
| | | | 1 | | 1 | 1 | | | 4601 Platform |
| | | | | | | | | | 4801 Side kickboard (optional) |
| | | | | | | | | | 4802 End kickboard (optional) |
| | | | 2 | | 4 | 2 | | | 4809 Platform handrail 20" |
| | | | 2 | 2 | | 2 | | | 4882 Platform side handrail 39" |
| | | | | | | | 1 | | 5401 Right booster rail |
| | | | | | | | 1 | | 5402 Left booster handrail |

Each package has a hardware package

On standard 32" or 44" sidewall bins the **35000 Platform** will go around the bin 4 bolt spaces or 37 1/2". The **12100** stair section will go around the bin 2 bolt spaces or 18 3/4". The **13200** Stair section will go around the bin 3 bolt spaces or 28 1/8". The **14400** stair section will go around the bin 4 bolts or 37 1/2". On bins with different size sheets the measurement will be the same but the bolt spacing may be

different. On these bins the wall brackets and kneebraces will have to be field drilled.

Regular platforms are 39" long and extend 26" from bin wall. All stair sections are 26" from outside siderail to bin wall and have a 6" wall bracket to hold away from the bin wall. The post and handrail will add another 1 1/2" to the width of the stairs and platform.

Installing Sidewall Stairs

Attach wall brackets (**2205** using the center hole of the wall bracket on the horizontal seam) and kneebraces to bin, using bin bolts with seals. If this is a new bin the brackets and sections can be put on as the bin is going up. If it is an existing bin install all the wall brackets and kneebraces on to the bin, then assemble and install the stairs starting from the bottom. One person can then climb the stairs as you are going up.

Installing stairs on a 44" sidewall.

Platform 5 ½" Below eave of bin. (See Fig. 1)

Use a **35000 Platform** on top.

Next a **13200 Stair section**.

Next a **14400 Stair section**. This is for the top 2 rings. Continue down the bin with **14400** sections. **Holes at the top of the Platform wall brackets will be field drilled.** The rest of the holes will fit on the horizontal hole punched in the bin.

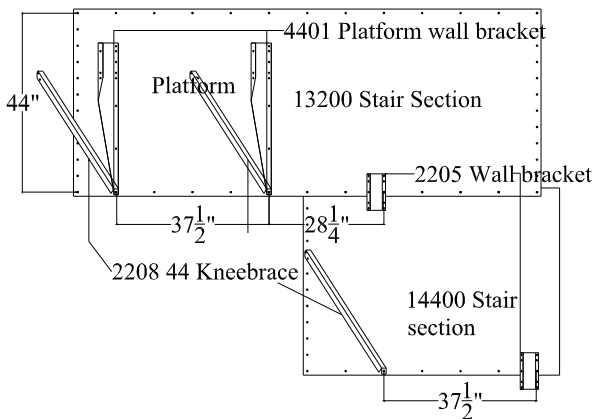

Figure 1 Platform at 5 ½" on 44" sheets

Platform 16" Below eave of bin. (See Fig. 2)

Use a **35000 Platform** on top.

Next a **12100 Stair section**.

Next a **14400 Stair section**. This is for the top 2 rings. Continue down the bin with **14400** sections. **Holes at the top and bottom of the Platform wall brackets will be field drilled.**

The rest of the holes will fit on the horizontal hole punched in the bin

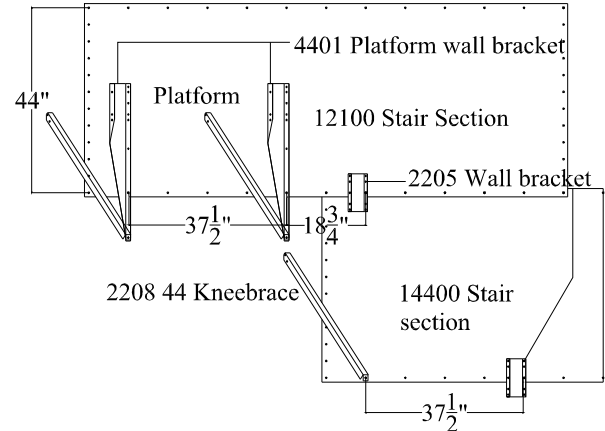

Figure 2 Platform at 16" on 44" sheets

Installing stairs on 32" sidewall

Platform 5 ½" Below eave of bin. (See Fig. 3)

Use a **35000 Platform** on top.

Next a **12100 Stair section**.

Next a **13200 Stair section**. This is for the top 2 rings. Continue down the bin with **13200** sections. **Holes at the top and bottom of the Platform wall brackets will be field drilled.** The rest of the holes will fit on the horizontal hole punched in the bin.

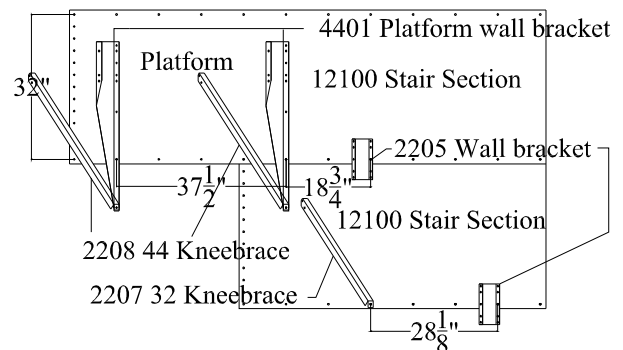

Figure 3 Platform at 5 ½" on 32" sheets

Platform 16" Below eave of bin. (See Fig. 4)

Use a **35000 Platform** on top.

Next a **14400 Stair section**.

Next a **13200 Stair section**. This is for the top 3 rings. Continue down the bin with **13200** sections. **Holes at the top and bottom of the Platform wall brackets will be field drilled.** The rest of the holes will fit on the horizontal hole punched in the bin.

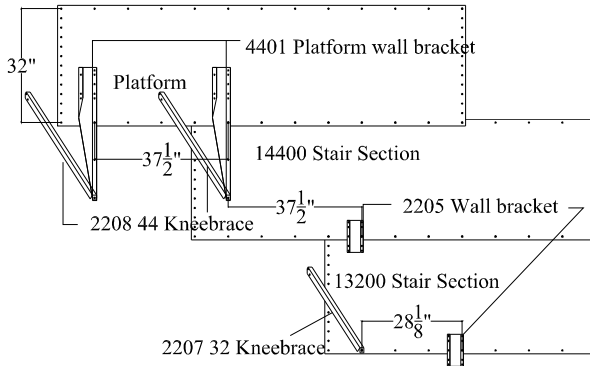

Figure 4 Platform at 16" on 32" sheets

The stairs and platform are assembled with 5/16 x 3/4 cap screws and 5/16 nuts. Use a 5/16 flatwasher on a slot.

Assembling the 35000 Platform. (See Fig.5)

After attaching wall brackets and kneebraces to the bin wall assemble the platform. First take the platform deck and attach the 4 corner posts. The post position will be determined by which way you are going around the bin.

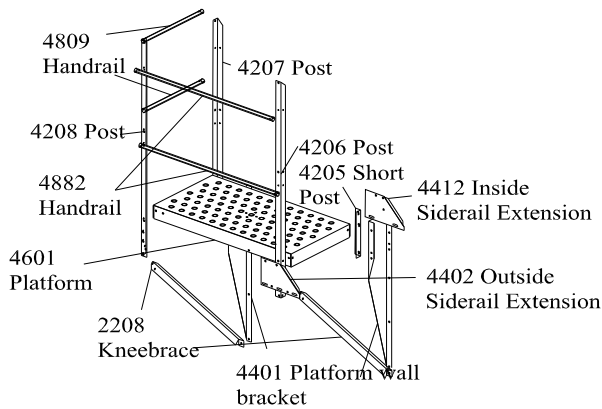

Figure 5 35000 Platform

Attach the inside and outside siderail extensions. The outside is the one with 7 holes.

Attach platform to the (4401) wall brackets and (2208) kneebraces on the bin. The top of the platform deck will be 3" above the top of the wall brackets. The kneebrace attaches to the platform post in the second and third holes from the bottom of the post. Attach the handrails. The handrails go on the outside of the posts and are attached with 5/16 x 1 1/2 carriage bolt and 5/16 whiz nuts. Tighten all bolts.

Assembling Stair Sections.

All of the stair sections go together the same way.

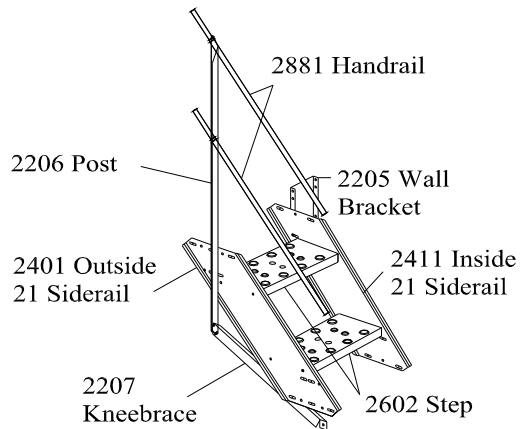

Figure 6 12100 Stair Section

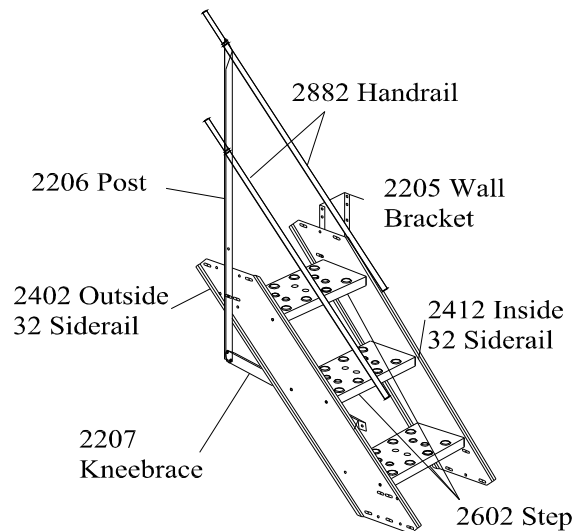

Figure 7 13200 Stair Section

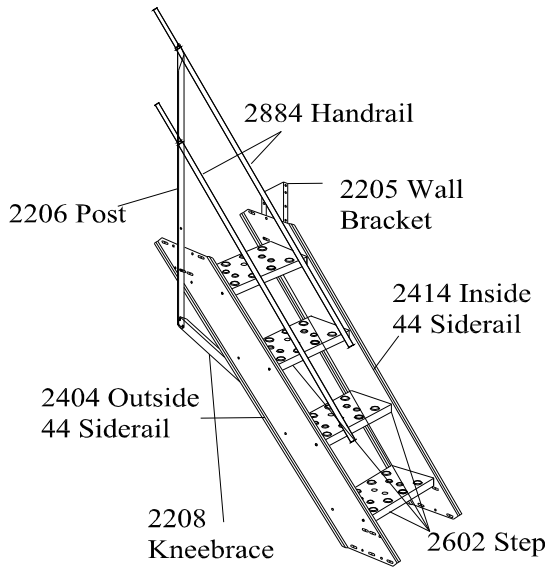

Figure 8 14400 Stair Section

Assembling sections

Attach the inside and outside siderails to the steps. The side of the step the siderails go on is determined by the direction the stairs go around the bin. The **Outside** siderail is the one with the 5 holes in the ends and is longer than the **Inside** siderail. Attach with the painted end up. The ends of the siderails will be parallel with the steps. On **14400** sections the outside siderail has slots where the upper and lower steps attach. The steps can be adjusted to fit the curve of the bin. These bolts will be tightened after the section is on the bin. Tighten the rest of the bolts.

Attaching sections to bin. (See Fig. 9)

Attach the inside siderail using the single slot (A and B) 4” from end of siderail to the wall brackets using the lowest hole (B) in the upper wall bracket and the highest hole in the lower wall bracket. (A)

Fasten the inside siderails together holes (C and D) using 5/16 bolts, nuts and flatwashers (since slots are present). At this time equalize the siderail on the slotted holes and tighten bolts.

Holes marked Note A is not used at this time.

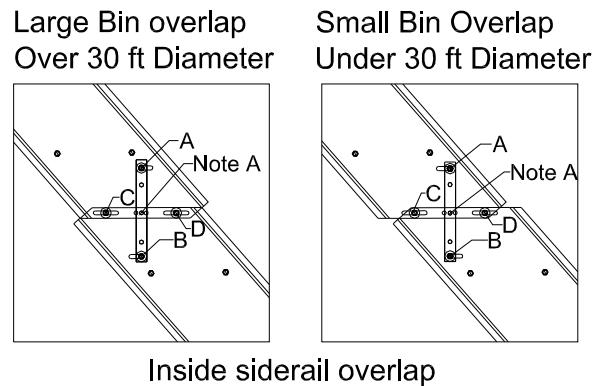

Figure 9

Attaching outside siderail (See Fig. 10)

Level the step farthest from the splice. Align the horizontal row of holes in the end of the siderail. There will be an offset in the upper and lower siderail depending on the diameter of the bin. The smaller the bin the longer outward lap, the larger the bin the longer the inward lap. Fasten the splice using the 2 most outward (E) holes that line up. Attach the post to the outside siderails using the upper and lower holes (F) of the set of 3. The center hole (Note B) is not used at this time.

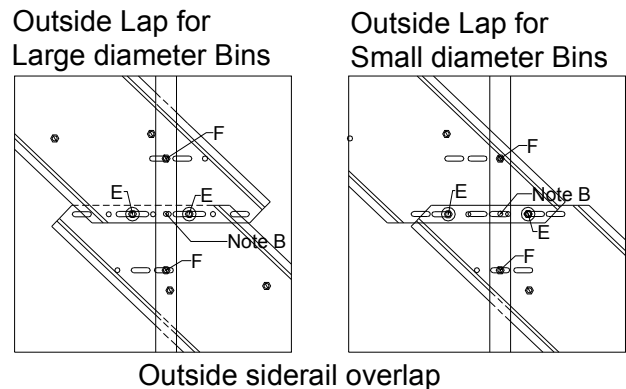

Figure 10

Attach the kneebrace to the end of the post. Level step and tighten bolts in outside siderail splice. Plumb post and tighten. Tighten all bolts in the sections. Attach the rest of the sections by repeating process.

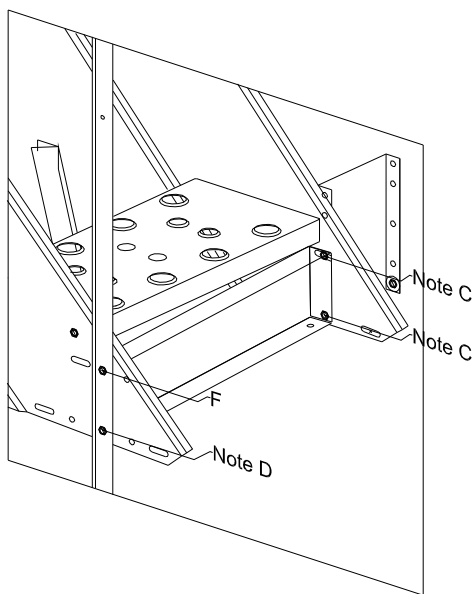

Figure 11

Bottom Knee Brace Bracket (See Fig. 11)

This item is shipped in the Stair Platform bundle but it goes at the very bottom of the stairs, place the long flange with the holes down. Attach to the inside siderail and the wall bracket using holes marked Note C. **This is the only time the hole marked Note A from figure 9 is used.**

Attach to the outside side rail and post using holes marked F and Note D. **(This is the only time this hole marked Note D is used).** Using the kneebrace that was replaced at the top section attach the kneebrace to the hole in the lower flange of the kneebrace bracket near the outside rail. Level step. Field drill the hole in the sidewall for the other end of knee brace and attach to bin wall. Tighten all bolts.

Attaching handrails

After all the sections are installed. Attach handrails. The stair handrails need to be arched to fit bin diameter. They should be arched so that the curve will match the side of the bin. As a guide place the handrail against the holes that the wall brackets are attached to. The upper rail should go on the outside of the post. The lower rail goes on the inside of the post. The handrails have 1 starter hole in the large

end. Check position of hole before bending handrail. Beginning at the bottom and progressing up the stairs attach the handrail with a self drilling stitch screw.

Read and follow directions carefully for installation. We are not responsible for damage or accidents caused by improper installation.

Our stairs are designed to hold one person and weight one person can carry per set.

Installing 36000 Intermediate Platform

The **36000 Intermediate Platform** will add one step to the rise of the stairs. The section above or below will need to be one step shorter. On a 44” sheet bin a **13200** section will be used either above or below the Intermediate Platform. On a 32” sheet a **12100** will be used.

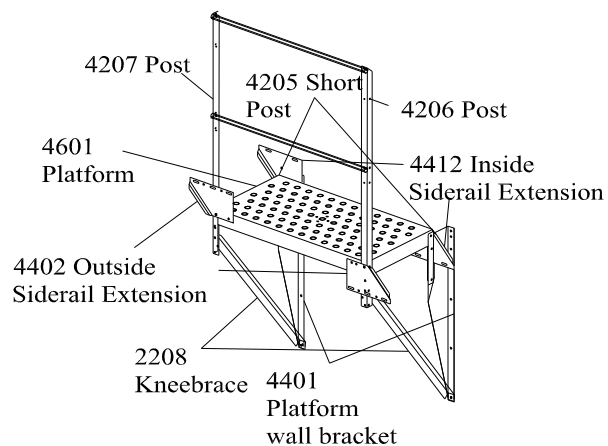

Figure 12 36000 Intermediate Platform

GIS0001-04

Easy Step Instructions



Please read this entire sheet before starting to avoid the need to disassemble and redo steps.

1. Platform Layout

ES3544 Platform rests 12" below the eave and the A-frame brackets are 4 bolt spaces apart (37 1/2"). It is recommended to place two thirds of the platform under the roof ladder with the remainder under the manhole. The ES2600 Stair Section attaches to the platform and has an A-frame 3 bolt spaces (28 1/8") from the platform A-frame. This Stair Section is included in the ES-3544 platform package.

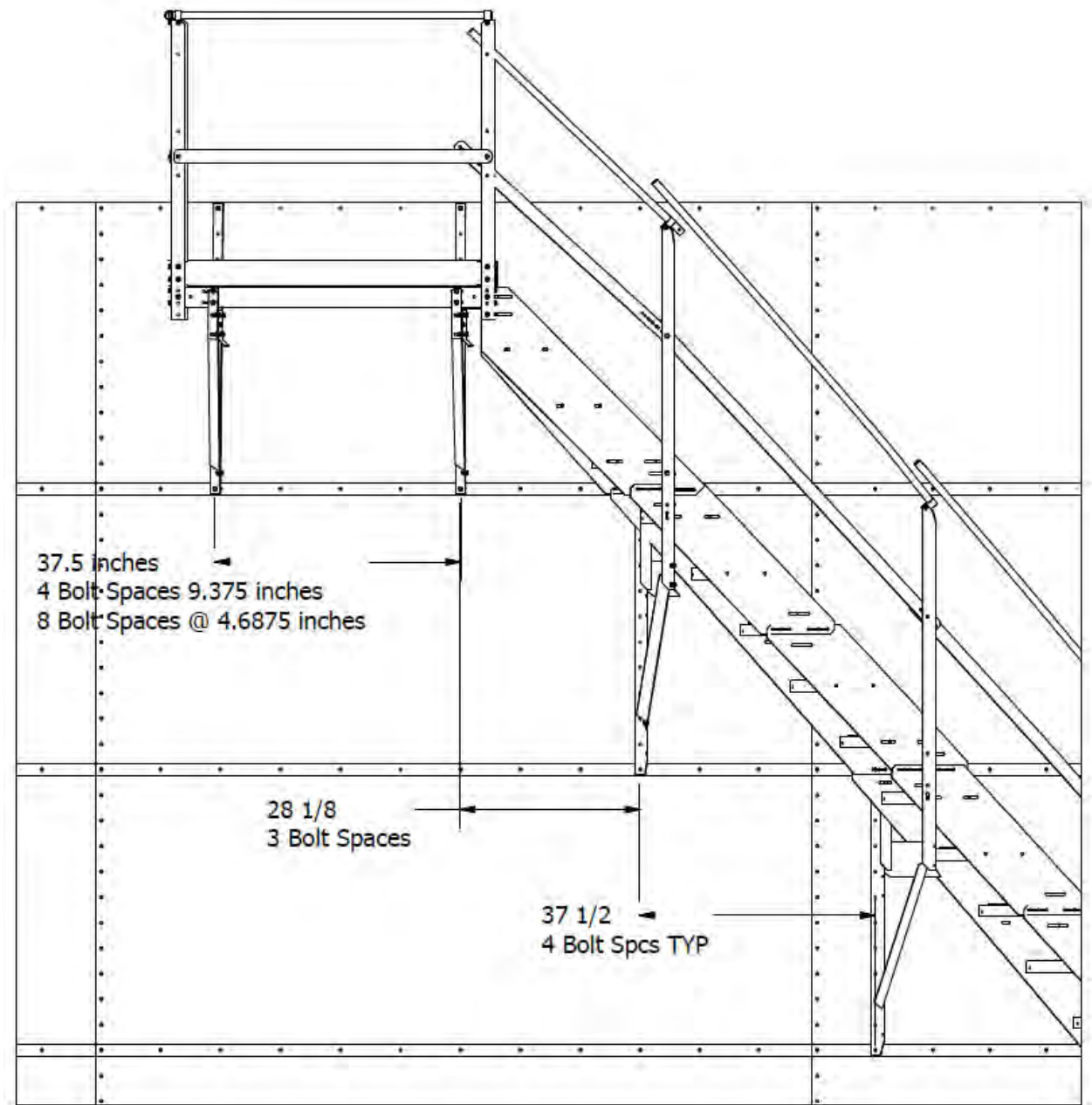

2. Intermediate Platform Layout

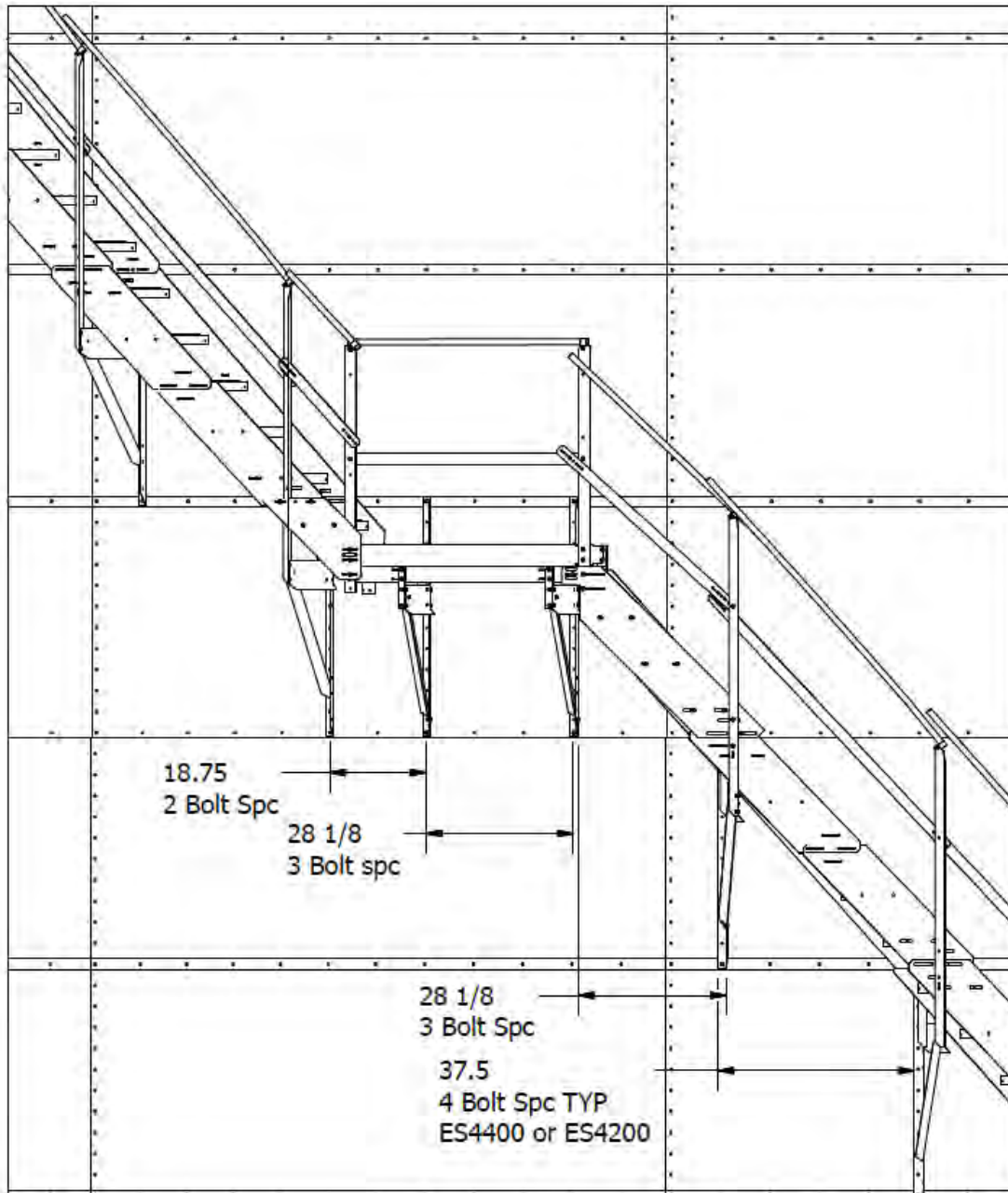

1. The platform should be laid out with the longer end toward the upward run of the stairs.
2. From the top down, the wall brackets are spaced 2, 3, 3 in terms of bolt spaces
 - **Two** from the last stair section
 - **Three** from the first intermediate platform wall bracket.
 - **Three** from the last intermediate platform wall bracket to the next stair wall bracket.
3. Platform A-frame wall brackets should be assembled like the platform layout shows in the instruction manual

3. Bottom Section Layout

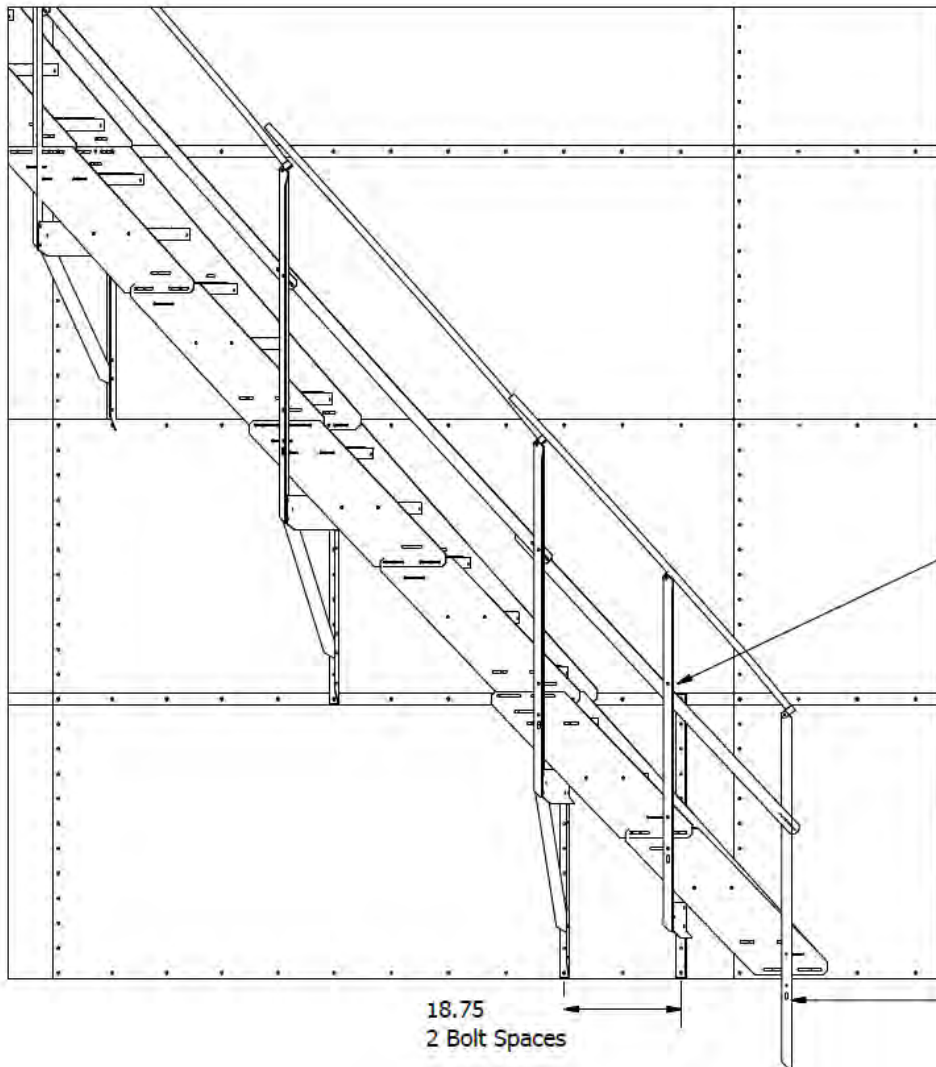

Field Drill

Post is included in the
stair platform
Cut to length at bottom

18.75
2 Bolt Spaces

GREENE
GALVANIZED STAIR

www.greenestairs.com
Case: Lynn IL 60932
217-375-0244 / 217-375-4245 FAX

| | | |
|----------|---------------------|-----|
| Drawn: | Mike | 1/1 |
| Check: | | |
| Scale: | | |
| Sheet: | A | |
| Project: | ES4400 Stair Layout | |
| Project: | ES4400 Stair Layout | |

Assemble Stair Sections

Painted end of Siderails are ALWAYS UP.

The ES4400 Stair Section has five steps. The A-frame attaches 4 bolt spaces (37.5") from the preceding A-frame.

The Outside Siderails on ES4400 Stair Sections are two-piece

Attach the steps and tighten the steps to the inside Siderail also tighten

the round-hole connections to the outside Siderail but leave the slot connections loose for later adjustment.

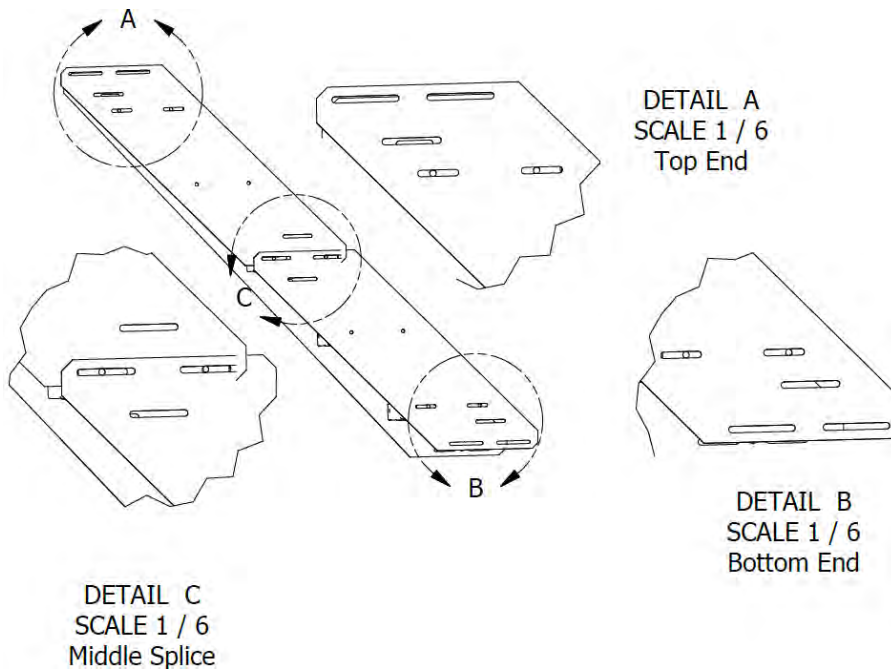
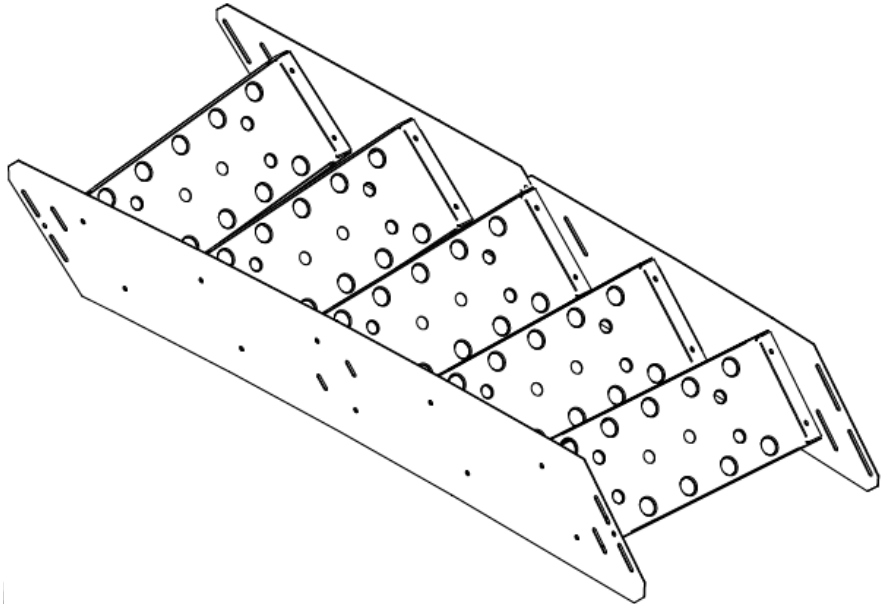

Assemble A-Frames

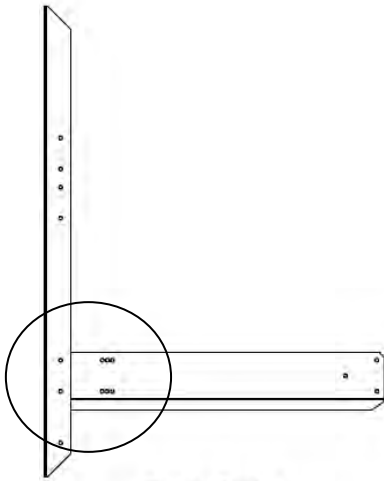

Bottom Bracket

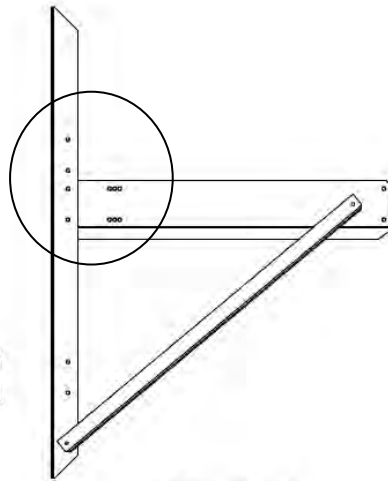

Platform Bracket

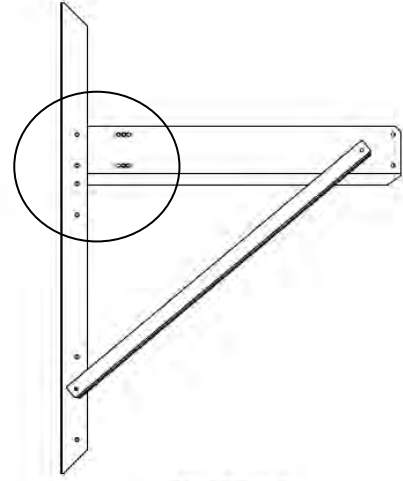

Stair Bracket

A-Frame Layout Drawing

DETAIL D
SCALE 1 / 9

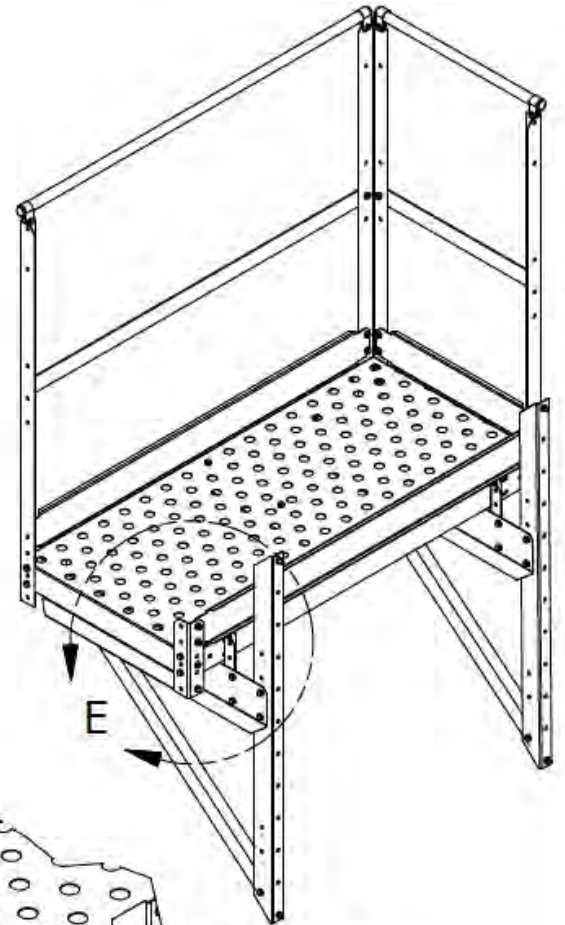
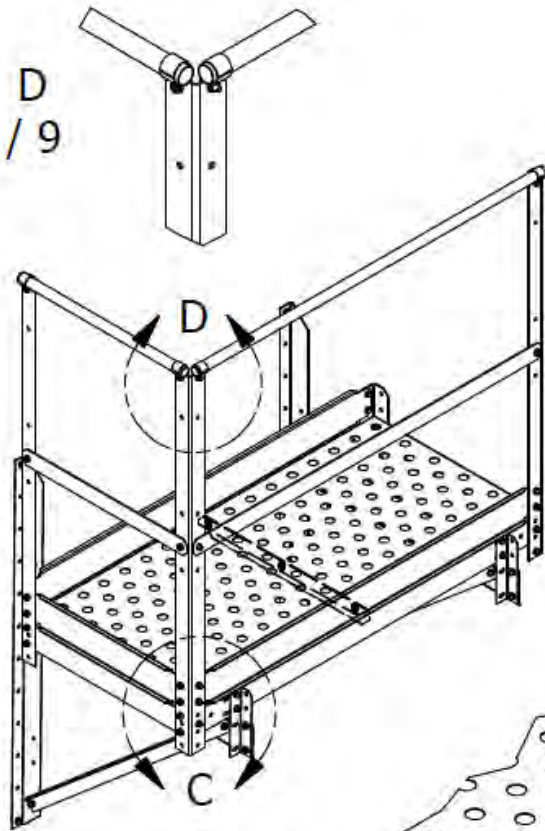

DETAIL E
SCALE 1 / 9

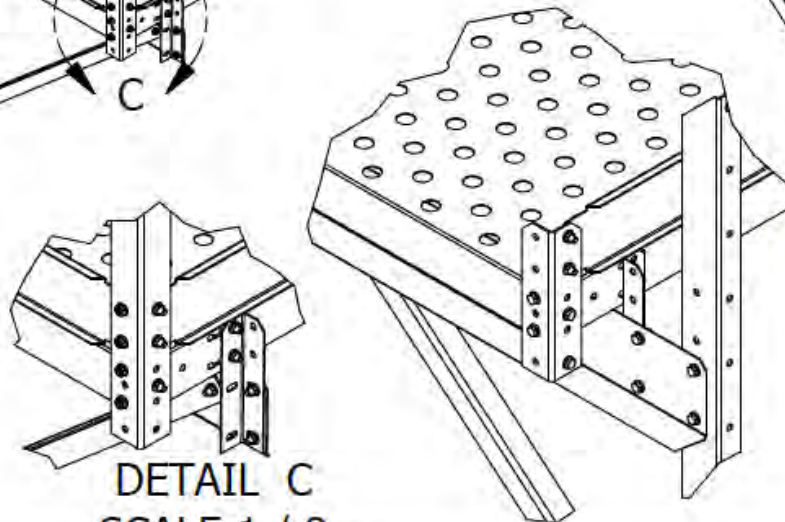

DETAIL C
SCALE 1 / 9

GREENE
GALVANIZED STAIRS

www.greenestairs.com
East Lynn IL 60932
217-375-4344 / 217-375-4345 FAX

| | | |
|--------------|-----------------------|--------------|
| DATE | Rev. Address | 5/9/2002 |
| E53500 BOM | | |
| REV | DESCRIPTION | |
| A | E53500 Stair Platform | |
| DO NOT SCALE | REV | SHEET 3 OF 3 |

Assemble the Platform

These Instructions are for putting the stairs on as the bin is being built.

Attach the platform A-frames to begin installation.

IMPORTANT: See wall bracket layout drawing for up and down indicator on wall bracket

Attach the mid brace to the bottom of the platform skin through the pre punched holes.

Attach Platform Skin to A-frames with the four short platform mount posts.

Attach the Platform posts and the kickboard post to the corners of the platform.

Attach the kick boards, hand and intermediate rails.

Attach Stair Section to platform with the hole in the platform skin and the bottom hole of the posts on the inside and outside Siderail. The shallow holes on the outside Siderail are for smaller bins (typ. 60' and under) and the deep holes are for larger bins. The top of the side rail is flush with deck to clear the kick board.

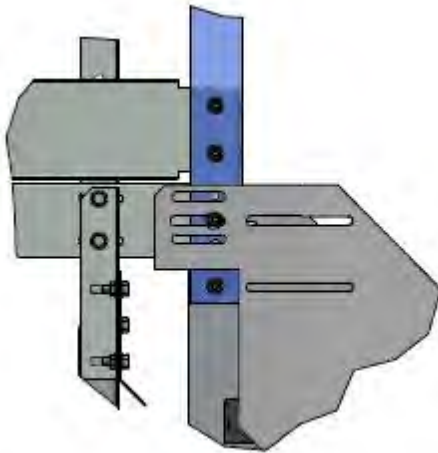

Outside Siderail Connection

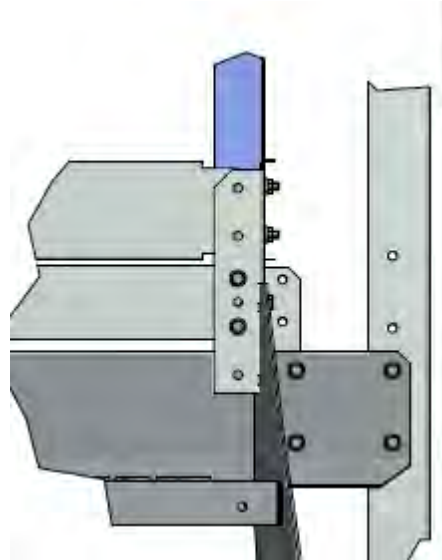

Inside Entry Detail

Try to keep the inside Siderail as close to the center of the adjustment slot as possible to keep the stairs from creeping forward down the bin. Continue to monitor this as you put successive sections on by watching the connections on the short post to the Siderail. Stay as close as possible to center and keep post plumb.

Tighten Stair Sections from the inside out and from the top down. Always level the bottom step before tightening the outside Siderail splice. Use the slotted connections on the outside Siderail to adjust steps for even fan pattern.

Tighten all connections

Attach Stair Sections

Attach the A-frame to the bottom of the Siderail using the top hole on the short post and the top hole (of the two) in the baluster post directly above the wall cross. After jacking the bin the A-frame will fit into place and be ready to attach the wall bracket to the bin wall.

The bin wall brackets call for one bolt at the top and bottom of the bracket on the horizontal bolt seam.

See layout section for attachment bolt spacing info.

When attaching ES4400 Stair Sections, use the same procedure as the Stair Section on the platform, except level the middle step and tighten the upper splice, then level the bottom step and tighten the middle splice.

ES4400 wall brackets are spaced 4 bolt spaces, or 37.5" around the bin.

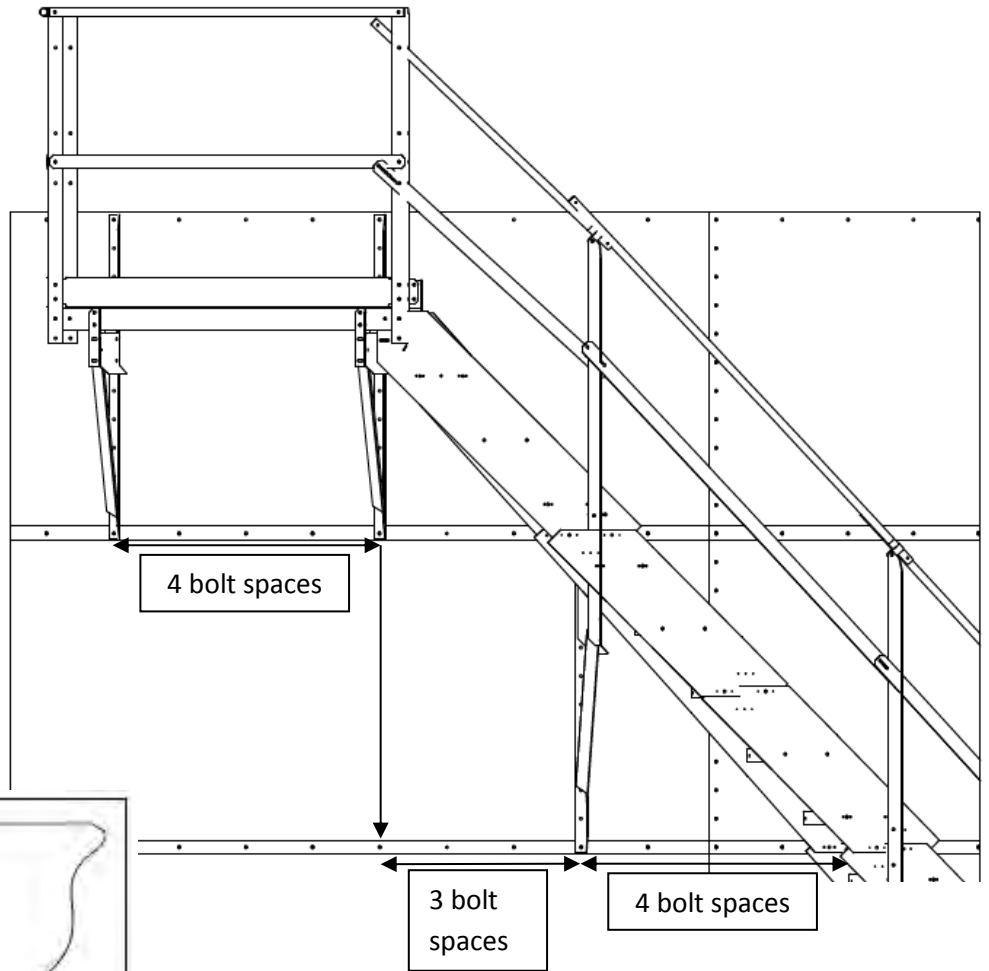
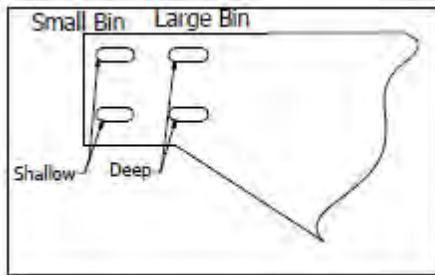

Attach Bottom Section

The bottom section uses a special configuration of the A-frame. For assembly see the A-frame drawing. It attaches in the middle of the Stair Section and it is two bolt spaces, or 18.75" +/- from the last wall mount.

There is an extra baluster post included with the platform that attaches to the bottom of the bottom section. This allows the handrail to end at the bottom of the stairs.

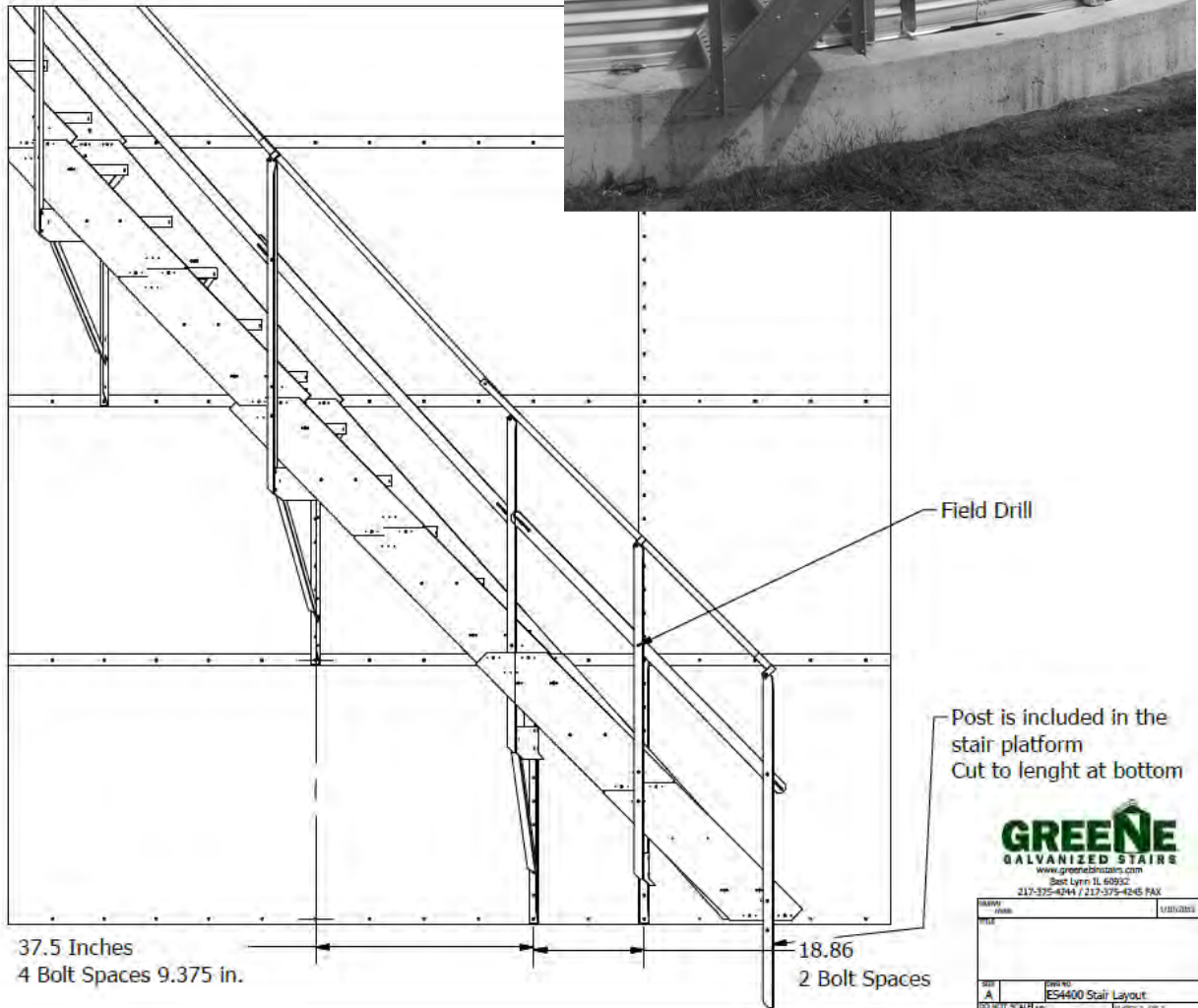

Attach Handrail

Shape the round handrail according to the circumference of the bin and attach them to the baluster posts using the coated “p-strap” with the **swaged end facing up** in the direction of the stair run. **The handrail clamp should be oriented outward. Insert the bolt through both holes on the handrail clamp, push the bolt through the hole in the baluster post, and fasten the nut to the outside so that the bolt head is on the inside of the stairs. Make sure the handrail clamp is fastened tightly together and the post is not between the two tabs. The bottom of each handrail section should be flush with the down hill edge of the Handrail Clamp. There is a self drilling screw for each stair section to screw the handrail into the handrail clamp.**

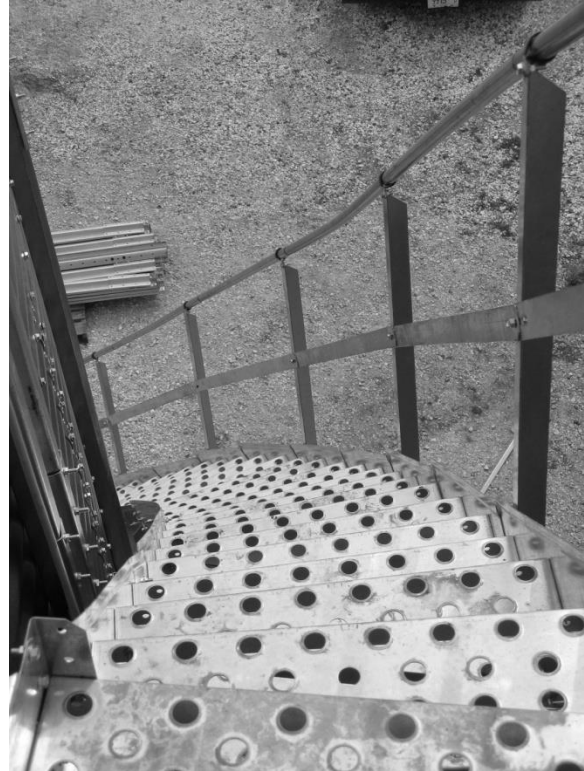

Intermediate rails bolt on the posts through the slots and are to be centered between each baluster post.

Recommended: Tubing Roll Former from Harbor Freight for Shaping Handrail to Bin Diameter.

Clamp it to the tailgate or make up a hitch adapter and have smooth shaped handrail.



Pittsburgh - Item#99736

