



Sweepway®

The power sweep unloading system

Owner's Installation & Operation Manual

Sukup Manufacturing Co.

1555 255th Street, Box 677

Sheffield, Iowa, USA 50475-0677

Phone: 641-892-4222

Fax: 641-892-4629

Website: www.sukup.com

E-mail: info@sukup.com

<u>DATES</u>	<u>REVISIONS</u>	<u>PAGES</u>
06/08/2018	– Updated warranty	4
06/08/2018	– Added instructions for applying operating instructions sticker to bin sidewall.....	7
06/08/2018	– Updated independent intermediate sump pull rod installation instructions	17
06/08/2018	– Updated 6" sump opener installation instructions	34
06/08/2018	– Updated operating instructions.....	37-38
06/08/2018	– Added references to sweep slowdown instructions	38 & 39
06/08/2018	– Updated Sweepway, unload tube backboard assy. drawings & parts lists	40-43
06/08/2018	– Updated 8" & 10" independent intermediate sump drawing & parts lists	64
06/08/2018	– Updated rack & pinion opener drawings & parts lists.....	72-73
06/08/2018	– Added drawings & parts lists for sweep auger support assy. & bin collar.....	78
10/02/2017	– Updated table & instructions for supporting floor over unload tube	14
10/02/2017	– Updated drawing & instructions for bin collar installation.....	17
10/02/2017	– Added note on sealing sumps if small grains will be stored in bin	19
10/02/2017	– Added note on rotating vertical auger shield 180° before attaching	28
10/02/2017	– Updated sump opener installation instructions.....	34-36
10/02/2017	– Added notice on leaving bottom panel of bin door open when sweep is running	38

Introduction

INTRODUCTION

Congratulations on your purchase of the Sweepway unload system. Your Sukup Sweepway is designed, built and tested to ensure highest quality and maximum life.

Read and study operator's manual carefully to learn how to safely install and operate your machine. Failure to do so could cause personal injury or equipment damage.

For your convenience, fill in the following information:

Sweepway: 6" _____ 8" _____ 10" _____ Bin Diameter: _____

NOTE: References to 6", 8" or 10" Sweepways refer to diameter of unload tube, not to diameter of sweep auger.

With Horizontal Unload: Single Motor Drive _____

With Vertical Unload: 16' _____ 20' _____

2 Motor Drive (2 Motor Top _____ 2 Motor Bottom _____) Single Motor Drive _____

25° Incline: 6" to 8" _____ 8" to 10" _____ 20° Incline: 10" to 12" _____

Date of Purchase: _____

DISCLAIMER: Bin sweeps will vary in performance based on grain condition and condition of bin floor. Any capacities provided by Sukup Manufacturing Co. are based on dry, clean corn and ideal conditions. It may take two passes over a given area to remove grain, with a layer of grain remaining on floor afterward.

TABLE OF CONTENTS

Introduction	2
Limited Warranty	4
Safety Section	5
General Safety Practices	5
Safety Decals for Sweepway	7
Safety Decals Placement for Sweepway	8
Sweepway Dimensions	9
Unload System Dimensions	10
Preparation / Unload Installation	12
Independent Intermediate Sump Pull Rod Installation	17
Assembling Bin Sweep	20
Attaching Sweep Stop	21
Backboard Scraper Installation	22
Cluster Buster Installation	24
Powerhead Options	26
... Horizontal with Single Motor Drive	26
... Basic Vertical Auger	27
... Two Motor Drive	28
... One Motor Drive	28
... Top Drive	29
... Incline	30
Inner Belt Shield Installation Guide	32
Adjusting Belt Tension	33
Sump Opener for 6" Sweepway	34
Sump Opener for 8" Sweepway	35
Sump Opener for 10" Sweepway	36
Operating Instructions	37
Troubleshooting Guide & Lubrication	39
Parts Assemblies	40
Quick Reference Parts List (Motors, Pulleys, Bushings)	79
Replacement Vertical Flighting, Shafts & Tubes	80
Unload Auger Flighting Assembly	81
Sweep Auger Replacement Kits	82
Contact Information	84



Sukup Manufacturing Co.
PO Box 677 Sheffield, IA USA 50475
Phone: 641-892-4222 Fax: 641-892-4629
E-mail: Info@sukup.com Visit us at: www.sukup.com

GRAIN HANDLING & MATERIAL HANDLING LIMITED WARRANTY

SUKUP MANUFACTURING CO. (Sukup) warrants to original retail purchaser that within time limits set forth, new equipment shall be free from defects in material and workmanship. A part will not be considered defective if it substantially fulfills performance specifications, such as cosmetic (appearance) issues that will not affect life of product. Should any part prove defective within the warranty period, the part will be replaced without charge F.O.B. Sukup Manufacturing Co., Sheffield, Iowa USA or Distribution Centers - Arcola, Illinois; Aurora, Nebraska; Defiance, Ohio; Jonesboro, Arkansas; Cameron, Missouri; Watertown, South Dakota. To obtain warranty, a copy of original invoice is required, see reverse side.

THE FOREGOING LIMITED WARRANTY IS EXCLUSIVE AND IN LIEU OF ALL OTHER WARRANTIES OF MERCHANTABILITY, FITNESS FOR PARTICULAR PURPOSE AND OF ANY OTHER TYPE, WHETHER EXPRESS OR IMPLIED. Sukup neither assumes nor authorizes anyone to assume for it any other obligation or liability in connection with said part, and will not be liable for incidental or consequential damages. **THE REMEDIES STATED HEREIN SHALL BE THE EXCLUSIVE REMEDIES AVAILABLE UNDER THIS LIMITED WARRANTY.**

Sukup reserves the right to change specifications, add improvements or discontinue manufacture of any of its equipment without notice or obligation to purchasers of its equipment. This warranty gives you specific legal rights. You may also have other rights which vary according to state or province.

WARRANTY EXCLUSIONS - Labor, transportation, or any cost related to a service call is not provided by Sukup. This Limited Warranty does not apply to damage resulting from misuse, neglect, normal wear, accident or improper installation or maintenance. **ITEMS NOT MANUFACTURED BY SUKUP (e.g. tires, belts, motors) ARE COVERED UNDER WARRANTIES OF THEIR RESPECTIVE MANUFACTURERS AND ARE EXCLUDED FROM COVERAGE UNDER THE SUKUP WARRANTY.** Since the stirring down augers are so critical to the successful operation of the stirring machine, Sukup Manufacturing Co. will not warranty any machines unless they are equipped with Sukup down augers. **SUKUP MANUFACTURING CO. MAKES NO WARRANTY, EXPRESS OR IMPLIED, WITH RESPECT TO DOWN AUGERS LONGER THAN 20', INCLUDING, WITHOUT LIMITATION, ANY WARRANTY OF MERCHANTABILITY AND WARRANTY OF FITNESS FOR A PARTICULAR PURPOSE.**

Upon taking delivery of product, purchaser (dealer and/or end user) assumes responsibility for proper storage of all materials. Proper storage includes dry, temperature and humidity controlled facilities, which eliminate the potential of moisture, including condensation, from causing white rust and/or corrosion of any sort. Warranty does not extend to defects, damage or cosmetic (appearance) issues caused by improper storage, handling or erection.

BASIC WARRANTY - All Sukup manufactured products are warranted for one year from date of purchase. Part(s) must be returned to Sukup within 30 days in event of failure.

EXTENDED STIRRING MACHINE WARRANTY - Sukup warrants stirring machines for two years from date of purchase.

EXTENDED STIRRING AUGER WARRANTY - Sukup warrants stirring down augers for two years from date of purchase. Must return top 18" of down auger to obtain credit.

EXTENDED FAN WARRANTY - Sukup warrants fans for two years from date of purchase.

EXTENDED HEATER CIRCUIT BOARD WARRANTY - Sukup warrants heater circuit boards for three years from date of purchase. Rebuilt circuit boards are warranted for one year from date of purchase.

EXTENDED MATERIAL HANDLING WARRANTY - Sukup warrants Material Handling, excluding structural support systems, for two years from date of purchase.

REPLACEMENT PARTS WARRANTY PERIOD - Sukup warrants replacement parts (e.g. belts, sensors, rotating contacts, gearmotors, switches) purchased from Sukup for one (1) full drying season following purchase.

ELECTRIC MOTOR WARRANTY - The manufacturers of electric motors warranty their motors through authorized service centers for a 2 year period from motor date code. Contact motor manufacturer for nearest location. If motor warranty is refused by a service center based upon date of manufacture, use the following procedure: Have motor repair shop fill out warranty report form as if they were providing warranty service. State on report reason for refusal. Send report, motor nameplate, and proof of purchase date (invoice from Sukup and invoice for your customer) to Sukup. If electric motor warranty is not satisfactorily handled by motor service center, contact Sukup for assistance. Sukup will attempt to obtain warranty from motor manufacturer, any credit obtained will be passed on. Warranty may also be obtained by returning motor to Sukup Manufacturing Co. or Distribution Centers with prior authorization. **NOTE:** Sukup will not be responsible for unauthorized motor replacement or repair. Labor for removal of motor from fan not included.

WARRANTY CERTIFICATION - Warranty registration card should be mailed within one month of product delivery to certify warranty coverage.

UNAPPROVED PARTS OR MODIFICATION - All obligations of Sukup under this warranty are terminated if unapproved parts such as stirring augers longer than 20' are used, or if equipment is modified or altered in any way not approved by Sukup.

Safety



Read manual before installing or using product. Failure to follow instructions and safety precautions in manual can result in death or serious injury. Keep manual in a safe location for future reference.



On safety decals, this symbol and the signal words Danger, Warning, Caution and Notice draw your attention to important instructions regarding safety.

They indicate potential hazards and levels of intensity.



RED - DANGER indicates an imminently hazardous situation which, if not avoided, will result in death or serious injury.



ORANGE - WARNING indicates a potentially hazardous situation which, if not avoided, could result in death or serious injury.



YELLOW - CAUTION indicates a potentially hazardous situation which, if not avoided, may result in minor or moderate injury.



BLUE - NOTICE alerts you to practices unrelated to personal injury, such as messages related to property damage.

IMPORTANT: To prevent serious injury or death to you or your family, it is essential that safety decals are clearly visible, in good condition, and applied to the appropriate equipment.

FOLLOW MANUAL & SAFETY DECAL MESSAGES

Carefully read this manual and all safety decals on your equipment. Safety decals must be kept in good condition. Replace missing or damaged safety decals by contacting Sukup Manufacturing Co. via mail at PO Box 677, Sheffield, Iowa USA, 50475; by phone at 641-892-4222; or by e-mail at info@sukup.com.

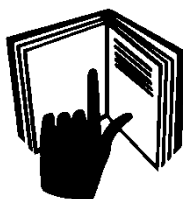

It is the responsibility of the owner/operator to know what specific requirements, precautions, and work hazards exist. It is also the responsibility of the owner/operator to inform anyone operating or working in the area of this equipment of hazards and safety precautions that need to be taken to avoid personal injury or death. Always keep children away from bins and vehicles with flowing grain.

Make no unauthorized modifications to machine. Modifications may endanger function and/or safety of unit. Keep unit in good working condition. Keep shields in place. Replace worn or missing shields free of charge by contacting Sukup Manufacturing Co.

GRAIN BIN SAFETY

Owners/operators are responsible for developing site-specific confined space entry procedures. OSHA's confined space entry procedures (29CFR 1910.146) can be found at www.osha.gov.

If you must enter bin for repair or maintenance:

- Use a safety harness, safety line and respirator
- Station another person outside of bin
- Avoid the center of the bin
- Wear appropriate personal protective equipment
- Keep clear of all augers and moving parts



DANGER: Never enter bin unless all power is locked out and another person is present.



Rotating augers can kill or dismember!

NEVER enter bin when augers are running!

When bin is nearly empty, sweep auger will travel at an increasingly fast speed. Keep away from sweep and sump augers to avoid entanglement.

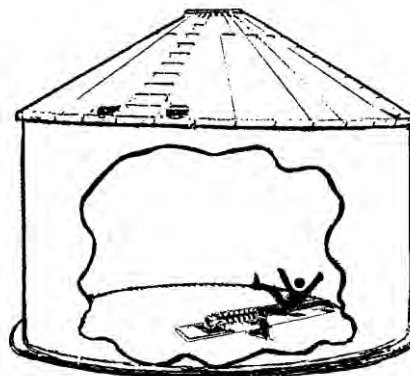

Failure to follow precautions above will result in death or serious injury.



DANGER: Flowing grain may trap and suffocate. If you enter a bin of flowing grain you can be completely submerged in grain in about 8 seconds.



Failure to heed this warning will result in death or serious injury.

Safety

To avoid electric shock or electrocution, all equipment must be properly wired and grounded according to electrical codes. Have unit wired by qualified electrician.



Have an electrician install a main power disconnect switch capable of being locked only in OFF position.

Mark disconnect clearly as to equipment it operates. Always lock out main power disconnect switch whenever equipment is not in use.

Service Disconnect

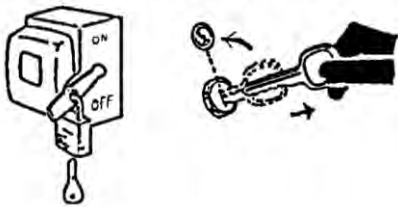

WARNING: When servicing equipment, never enter bin unless all power is locked out and another person is present. Always LOCK OUT all power and always check with voltage meter before servicing.

Failure to do so could result in death or serious injury.

Owners/operators are responsible for developing site-specific Lockout/Tagout procedures based on equipment at their work site. See OSHA's typical minimal lockout procedures (29CFR 1910.147 App A) at www.osha.gov.

WARNING: KEEP CLEAR OF ALL MOVING PARTS.

Keep people (ESPECIALLY YOUTH) away from equipment, particularly during operation.

Keep away from all moving parts. Keep all shields in place. **SHUT OFF AND LOCK OUT** all power before servicing.

Failure to follow precautions above could result in death or serious injury.



WARNING: Metal is slippery when wet. To avoid falls, never carry items if climbing on bin. Maintain secure hand and foothold if climbing on bin. Failure to do so could result in death or serious injury.

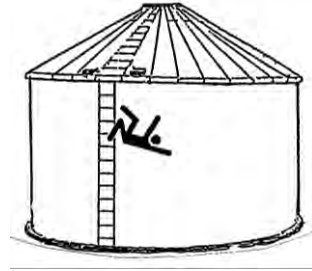

CAUTION: Metal edges are sharp. To avoid injury, wear protective clothing and handle equipment and parts with care.

Failure to do so may result in minor or moderate injury.

PERSONAL PROTECTIVE EQUIPMENT



Refer to OSHA 1910.132 (Personal Prot. Equip.)

Owners/Operators are responsible for developing site-specific personal protective equipment standards. OSHA's personal protective equipment standards (29CFR 1910.132) can be found at www.osha.gov.

EMERGENCIES – KNOW WHAT TO DO

Have emergency numbers and written directions to work site readily available in case of emergency. An area for emergency phone numbers to be recorded is provided below and at end of this manual.

Ambulance • Fire • Police: 9-1-1

Bin rescue team: _____

Emergency medical squad: _____

Address of work site: _____

Directions to work site: _____

Safety Decals for Sweepway

Safety decals should be mounted on your equipment as shown in this safety section. Yearly and prior to equipment use, check that all decals and shields are in place and legible.

To order a replacement decal or shield at no charge, contact your dealer or Sukup Manufacturing Co., Box 677, Sheffield, IA USA 50475. If replacement is necessary, make sure location for decal is free from grease, oil and dirt. Remove backing from decal and place in proper position.

Decals 1-5 are factory-mounted. Additional copies of decals 1 and 4 are shipped with this manual in separate packet #A3399 and have mounting instructions inside packet.

IMPORTANT: If suggested locations are not clearly visible, place safety decals in a more suitable area. Never cover up any existing safety decals.

- DECAL L0281 – WARNING:** To avoid serious injury or death. Mount this decal on bin sheet near door handle.

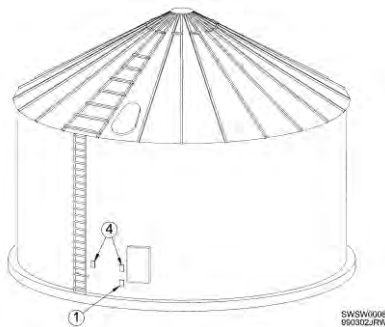

- DECAL L0271 - DANGER:** Shield missing. Do not operate!



- DECAL L0284 – WARNING:** Keep away from all moving parts.



- DECAL L0258A – DANGER:** Do not enter this bin! Keep clear of all augers. Mount this decal on bin sheet near door handle and near ladder leading to roof.



- DECAL L03061 – DANGER:** Keep away when auger is running!



- DECAL L0328 – Sweepway Operation.** Mount this decal on bin sidewall near sump openers.



Safety Decals Placement for Sweepway

HORIZONTAL

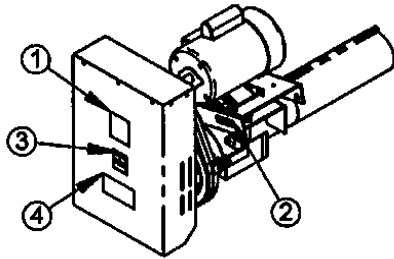

STANDARD ONE MOTOR DRIVE

VERTICAL BOOT

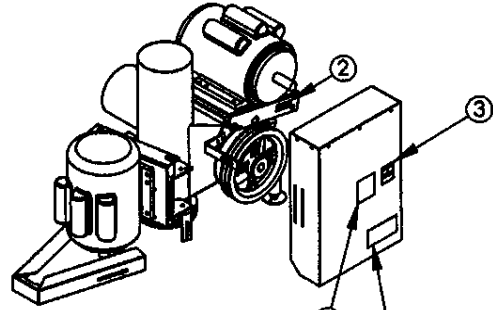

TWO MOTOR DRIVE (STANDARD)

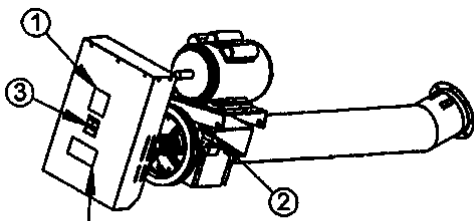

INCLINE HORIZONTAL DRIVE

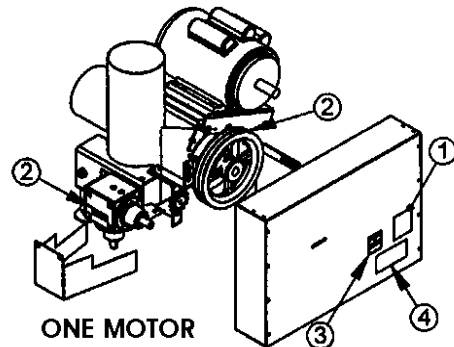

ONE MOTOR DRIVE OPTION

SWEEP BACKBOARD

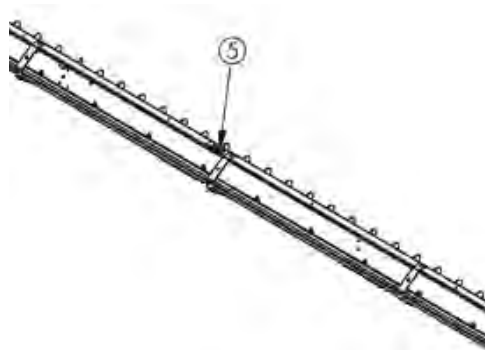

SWEEPWAY DIMENSIONS

See Fig. 1 and Table 1 for Sweepway dimensions.

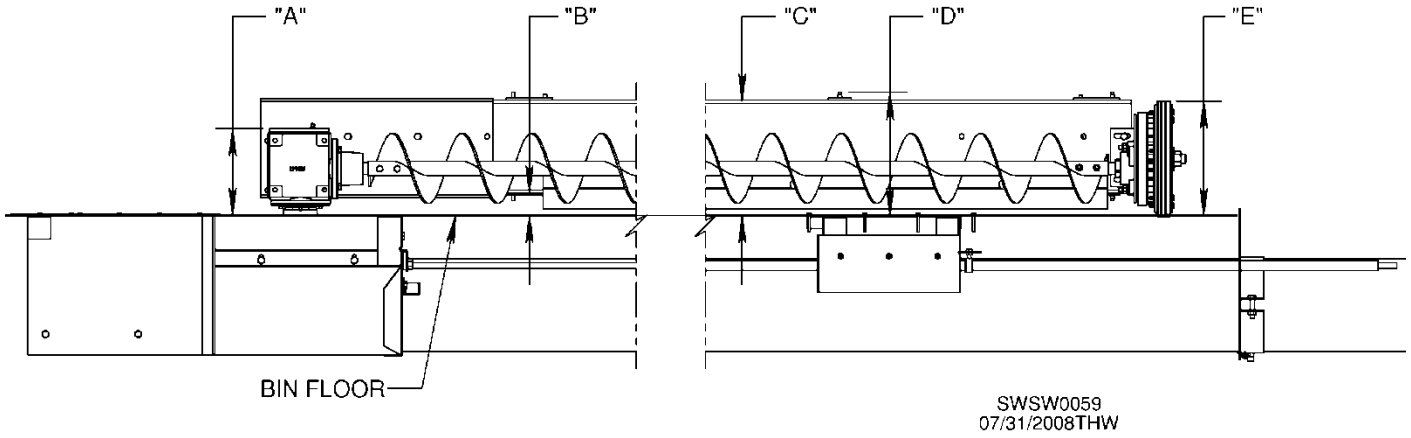

Fig. 1 & Table 1 – Sweepway dimensions

DIMENSION	DISTANCE FROM BIN FLOOR	6"	8"	10"
A	Top of gearbox	7-1/2"	7-1/2"	8-1/2"
B	Bottom of backboard	3"	2"	2-5/8"
C	Top of backboard	11-1/4"	9-7/8"	12-5/8"
D	Top of huckbolt sleeve	11-3/4"	10-3/8"	13-1/8"
E	Top of reduction wheel	10"	10" *	10" *

*Dimension E will be 17" if 17" wheel is used on 8" or 10" Sweepway

Dimensions

UNLOAD SYSTEM DIMENSIONS

See Fig. 2 and Tables 2-6 for approximate dimensions of unload systems.

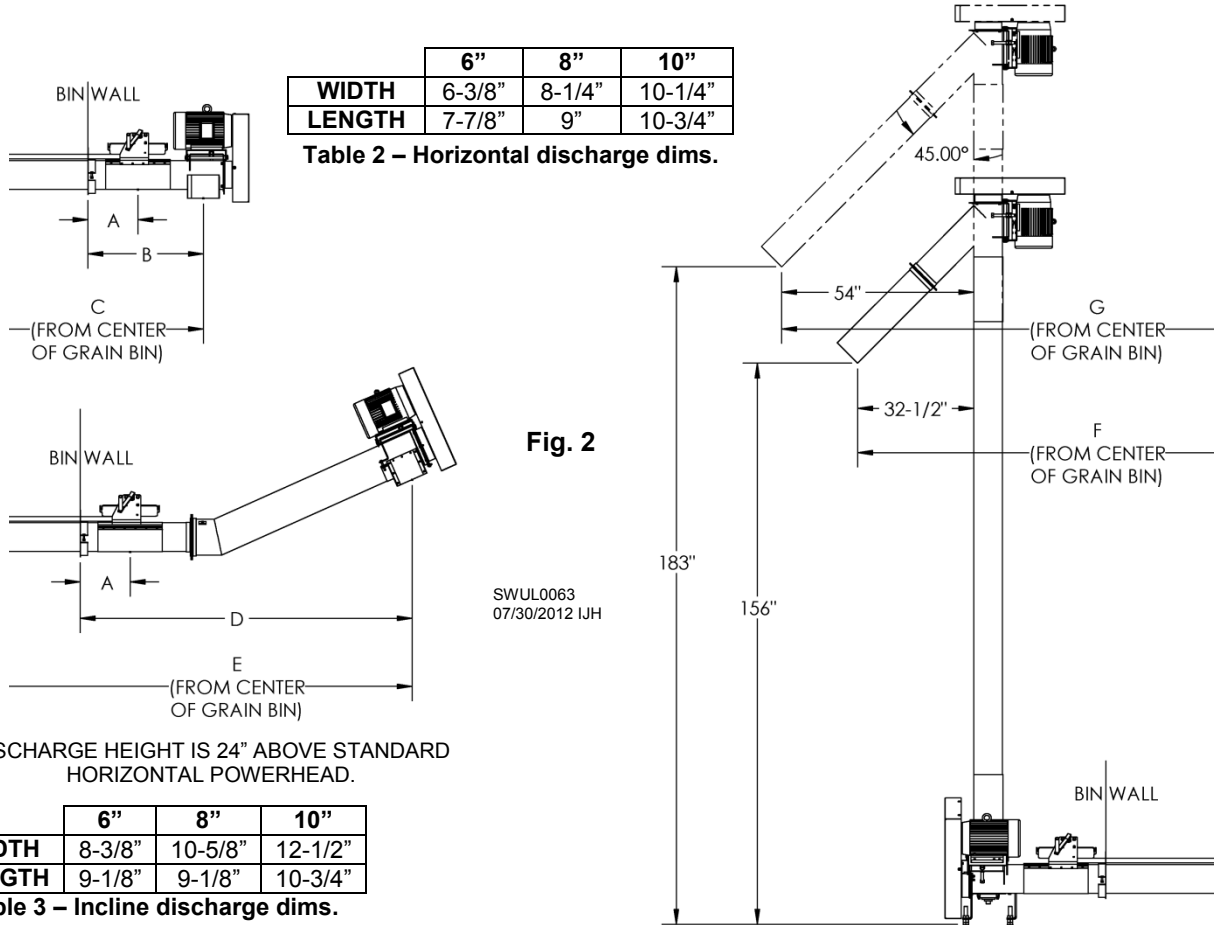

Table 4 – Unload system dimensions for 6" Sweepway

BIN DIA.	6" SWEEPWAY DIMENSIONS						
	A	B	C	D	E	F	G
15'	17	35	125	99	189	163	184.5
15' 6"	14	32	125	96	189	163	184.5
16' 5" (5M)	12	30	128.5	94	192.5	166.5	188
18'	17.5	35.5	143.5	99.5	207.5	181.5	203
18' 7"	14	32	143.5	96	207.5	181.5	203
19' 8" (6M)	14	32	150	96	214	188	209.5
21'	18	36	162	100	226	200	221.5
21' 8"	14	32	162	96	226	200	221.5
22' 11" (7M)	14.5	32.5	170	96.5	234	208	229.5
24'	18	36	180	100	244	218	239.5
24' 9"	13.5	31.5	180	95.5	244	218	239.5
26' 3" (8M)	14.5	32.5	190	96.5	254	228	249.5
27'	19	37	199	101	263	237	258.5
27' 10"	14	32	199	96	263	237	258.5
29' 6" (9M)	14	32	209	96	273	247	268.5
30'	20	38	218	102	282	256	277.5
31'	14	32	218	96	282	256	277.5
33'	20	38	236	102	300	274	295.5
34'	14	32	236	96	300	274	295.5
36' (11M)	20	38	254	102	318	292	313.5
37' 1"	13.5	31.5	254	95.5	318	292	313.5

IMPORTANT:
Dimensions are based on nominal bin diameters listed and provide approximate measurements for planning and layout purposes.

Dimensions

Table 5 – Unload system dimensions for 8” Sweepway

BIN DIA.	8” SWEEPWAY DIMENSIONS						
	A	B	C	D	E	F	G
15'	17	35	125	95	185	162.5	184
15' 6"	14	32	125	95	185	162.5	184
16" 5" (5M)	14.5	32.5	131	92.5	191	168.5	190
18'	17.5	35.5	143.5	95.5	203.5	181	202.5
18' 7"	14	32	143.5	92	203.5	181	202.5
19' 8" (6M)	14	32	150	92	210	187.5	209
21'	18	36	162	96	222	199.5	221
21' 8"	14	32	162	92	222	199.5	221
22" 11" (7M)	14.5	32.5	170	92.5	230	207.5	229
24'	18	36	180	96	240	217.5	239
24' 9"	13.5	31.5	180	91.5	240	217.5	239
26' 3" (8M)	14.5	32.5	190	92.5	250	227.5	249
27'	19	37	199	97	259	236.5	258
27' 10"	14	32	199	92	259	236.5	258
29' 6" (9M)	14	32	209	92	269	246.5	268
30'	20	38	218	98	278	255.5	277
31'	14	32	218	92	278	255.5	277
33'	20	38	236	98	296	273.5	295
34'	14	32	236	92	296	273.5	295
36' (11M)	20	38	254	98	314	291.5	313
37' 1"	13.5	31.5	254	91.5	314	291.5	313
42'	14	32	284	92	344	321.5	343
42' 8" (13M)	14	32	288	92	348	325.5	347
43' 3"	14	32	291.5	92	351.5	329	350.5
48'	14	32	320	92	380	357.5	379
49' 3" (15M)	15	33	328.5	93	388.5	366	387.5
54'	14	32	356	92	416	393.5	415
55' 8"	14	32	366	92	426	403.5	425
60'	14	32	392	91	452	429.5	451
61' 10"	14	32	403	92	463	440.5	462

IMPORTANT:
Dimensions are based on nominal bin diameters listed and provide approximate measurements for planning and layout purposes.

Table 6 – Unload system dimensions for 10” Sweepway

BIN DIA.	10” SWEEPWAY DIMENSIONS						
	A	B	C	D	E	F	G
24'	30	48	192	137	281	236.5	258
24' 9"	25.5	43.5	192	132.5	281	236.5	258
26' 3" (8M)	24	42	199.5	131	288.5	244	265.5
27'	31	49	211	138	300	255.5	277
27' 10"	26	44	211	133	300	255.5	277
29' 6" (9M)	26	44	221	133	310	265.5	287
30'	32	50	230	139	319	274.5	296
31'	26	44	230	133	319	274.5	296
33'	32	50	248	139	337	292.5	314
34'	26	44	248	133	337	292.5	314
36' (11M)	32	50	266	139	355	310.5	332
37' 1"	25.5	43.5	266	132.5	355	310.5	332
42'	26	44	296	133	385	340.5	362
42' 8" (13M)	24	42	298	131	387	342.5	364
43' 3"	26	44	303.5	133	392.5	348	369.5
48'	26	44	332	133	421	376.5	398
49' 3" (15M)	27.5	45.5	341	134.5	430	385.5	407
54'	26	44	368	133	457	412.5	434
55' 8"	26	44	378	133	467	422.5	444
60'	26	44	404	133	493	448.5	470
61' 10"	26	44	415	133	504	459.5	481

PREPARATION / UNLOAD INSTALLATION

Unload tube can either be placed in a bin with a steel aeration floor as shown in Fig. 3 or a concrete trench as shown in Fig. 7. Instructions are provided for both types of floor. In either case, the first step is to determine from which side of bin grain will be unloaded.

Unloading tube must have unobstructed path to center sump, and center of top gearbox must be in exact center of bin as shown in Figs. 3 and 7. Locate center of bin by taking several measurements.

For installation in full aeration floor:

NOTE: Instructions are written for installation prior to floor installation, and for when floor is arranged as shown in Fig. 3. Ensure there are adequate floor supports used around unload tube.

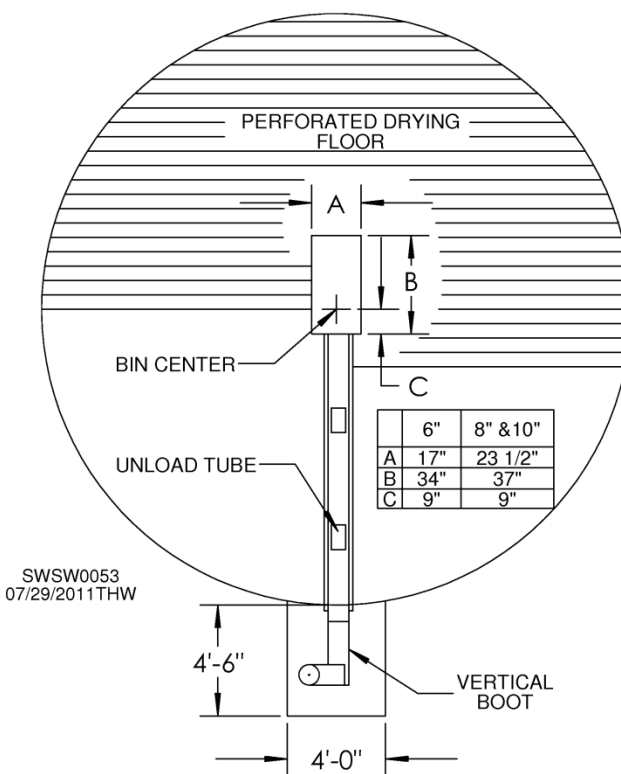

Fig. 3 & Table 7

NOTE: If installing in existing bin with a full aeration floor, it may be necessary to remove about half of floor.

Before installation, check floor height.

Minimum plenum height required for installation of sweep is:

- 6" sweep ----- 12"
- 8" and 10" - 13-1/4"

Maximum floor thickness is:

- 6" and 8" ----- 2-3/4"
- 10" ----- 1-3/4"

Preparation / Installation

Cut hole in bin wall at desired unloading location, with center of hole located as shown in Fig. 4, depending on size of unload tube.

- 6" Sweep, cut 6-1/4" U-shaped opening
- 8" Sweep, cut 8-1/4" U-shaped opening
- 10" Sweep, cut 10-1/4" U-shaped opening

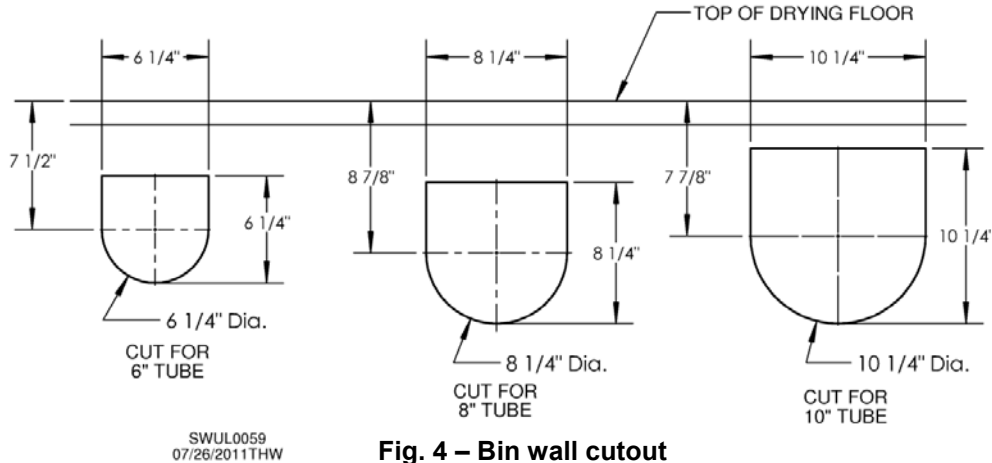

Fig. 4 – Bin wall cutout

If floor has not previously been installed, install half of bin floor on side opposite of unload, plus two planks past center of bin. **NOTE:** Floor planks must run perpendicular to unload tube.

Position center sump so that center of top gearbox is at exact center of bin. Align center sump with bin wall opening. With spray paint, mark pattern around sump on floor planks. Cut appropriate size hole for sump. See Fig. 3.

Position center sump so unloading tube attachment points toward bin wall opening. Support center sump at bottom, if necessary, using non-flammable material. Place extra floor supports around sump for additional support.

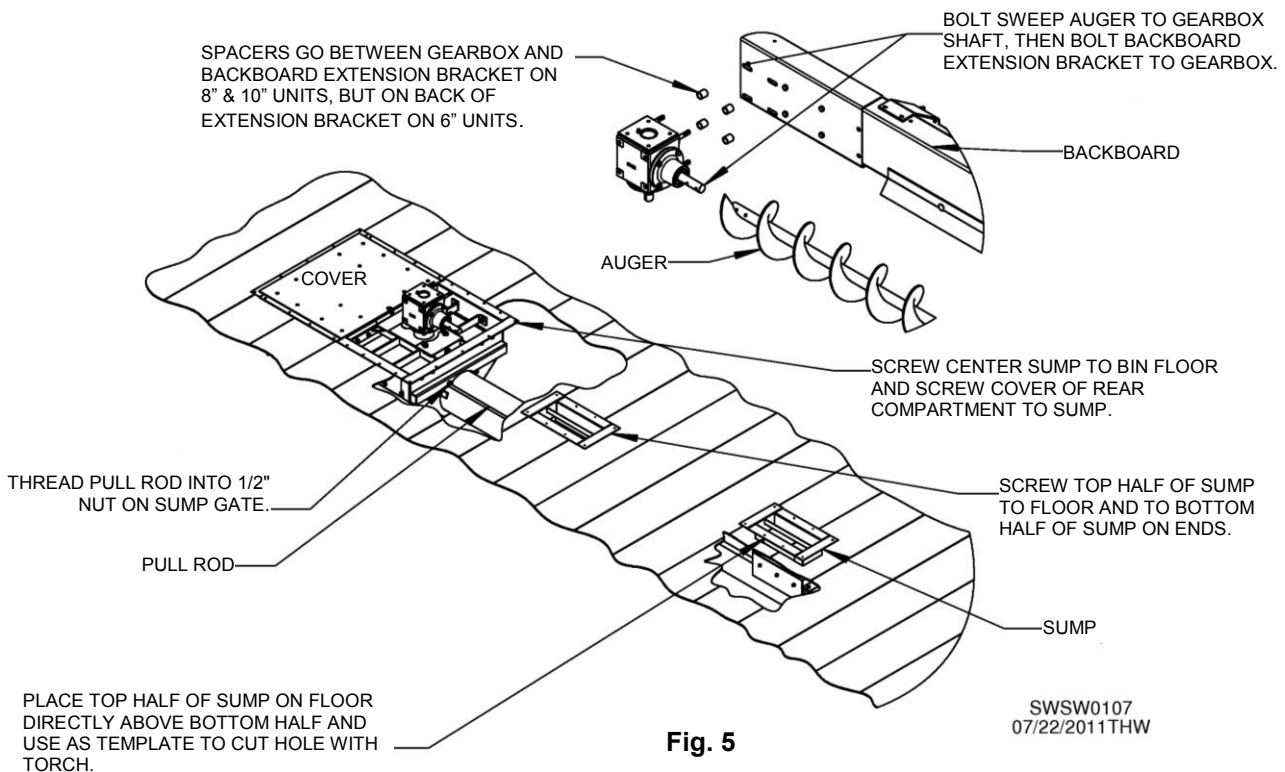

Fig. 5

Installation

In addition to floor supports specified in flooring installation instructions, supports such as Sukup Double Super Supports must be placed between unload tube and clutch rod as shown in Fig. 6 to provide adequate floor support above tube. **NOTE:** Drawing shows Hawk Cut flooring but also applies to Heavy-Duty Perforated flooring.

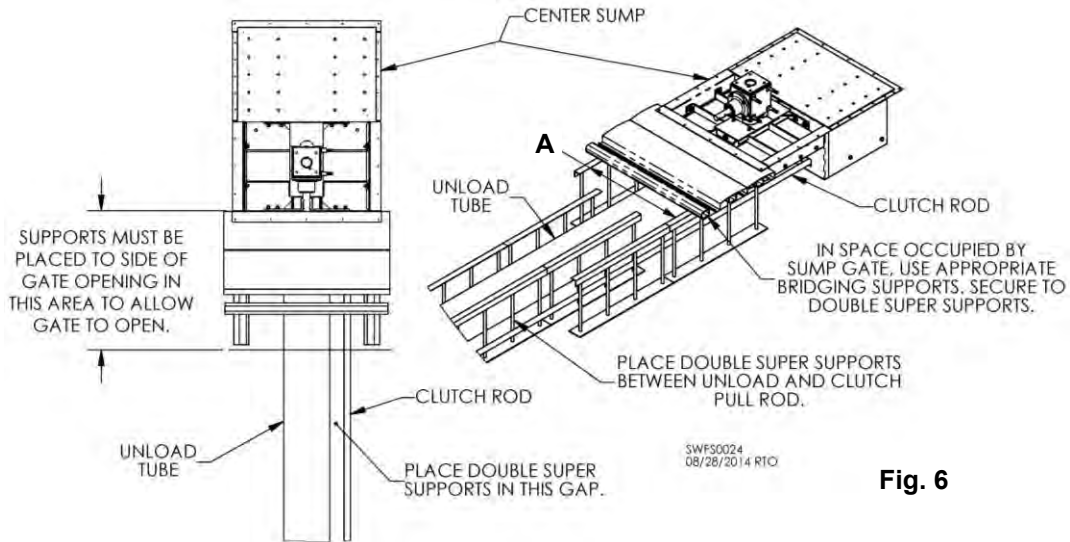

Fig. 6

If flooring manual says floor supports should be placed closer than Dimension A in Table 8, then bridging is needed to support floor planks over void left for sump gate when it is open, as shown in Fig. 6.

UNLOAD TUBE DIA.	DIMENSION A	FLOORING/BIN DIA./EAVE HEIGHT					
		HAWK CUT		20ga HD PERF		18ga HD PERF	
6"	16"	≤48'	54'-78'	≤48'	54'-78'	≤48'	54'-78'
8"-10"	26"	68'	64'	76' 6"	72'	78' 2"	73' 7"
		26'	20'	31'	25'	38'	32'

If bridging is used, it should be at center of each floor plank over unload tube. If two-channel planks are used, bridging should be in same channel of each plank (7" spacing on bridging). Bridging should at minimum be made of 1-1/4 x 1-1/4" high-strength steel tube with a thickness of 1/8", or material of similar strength. Bridging tubes must be kept from sliding off of supports using tabs, screws or other means.

IMPORTANT: Floor supports used for bridging do not count as part of floor support system. See Sukup Channel-Lok Bin Floors & Supports manual for floor support requirements.

If using Double Super Supports, place on each side of sump and unload tube as shown in Fig. 6, making sure to anchor Double Super Support bases to concrete using concrete screws or wedge anchors.

Two bridging tubes must be used under each plank if eave height of bin is greater than applicable height listed in Table 8. Also, two Double Super Supports must be placed on each side of sump and unload tube if using two floor support tubes under each plank. Values in Table 8 are based on 15-7/8" floor supports and assume unload is not in a trench.

Installation

For installation in concrete trench:

Ensure trench meets dimensions shown in Fig. 7 and Table 9. Trench will need to be formed when foundation is poured. Because of moving slide gates and pull rods, concrete CANNOT be poured over sweep tube. After tube installation, cover trench with Channel-Lok flooring or other suitable material.

Position center sump as shown in Fig. 7 so top of gearbox is at exact center.

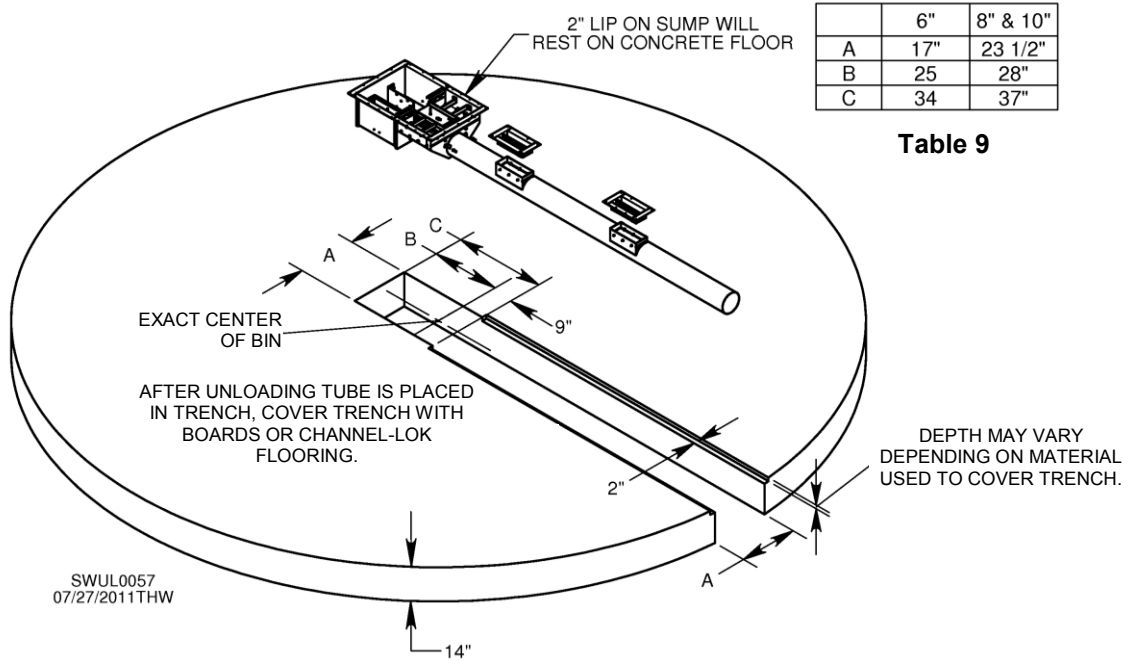

	6"	8" & 10"
A	17"	23 1/2"
B	25	28"
C	34	37"

Table 9

Fig. 7

SWUL0057
07/27/2011THW

For installation in either application:

A concrete pad, 4' 6" x 4' measured from bin foundation, is required for unload systems using vertical boot drive. Pad should be poured below level of concrete floor of bin, as shown in Fig. 8. Use Plenum Height table to determine pad offset (B) from bin floor. **NOTICE:** In northern locations, frost can lift pad, causing damage to unload system. Loosen threaded support legs in winter and re-tighten in spring.

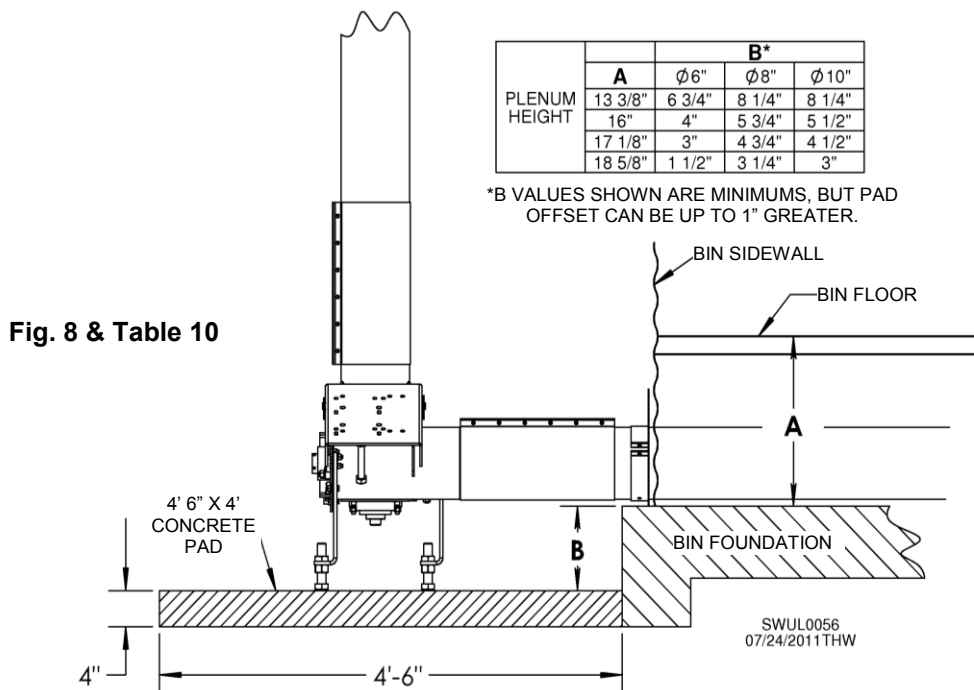

PLENUM HEIGHT	A	B*		
		Ø6"	Ø8"	Ø10"
13 3/8"	6 3/4"	8 1/4"	8 1/4"	8 1/4"
16"	4"	5 3/4"	5 1/2"	5 1/2"
17 1/8"	3"	4 3/4"	4 1/2"	4 1/2"
18 5/8"	1 1/2"	3 1/4"	3"	3"

*B VALUES SHOWN ARE MINIMUMS, BUT PAD OFFSET CAN BE UP TO 1" GREATER.

Fig. 8 & Table 10

SWUL0056
07/24/2011THW

Installation

For installation in both floor types:

With tabs on unloading tube closest to center sump, slide unloading tube out slightly through bin wall and then back **into sump**. Position tube so intermediate sumps are straight up. Bolt tube to sump using attachment tabs welded onto tube, and holes provided in sump.

Connect extension sections of auger, if applicable, as shown in Fig. 9.

WITH OVERLAP

When adding an extension, flighting overlap needs to be on backside of grain flow. This will limit wear problems and put least amount of stress on flighting.

Fig. 9

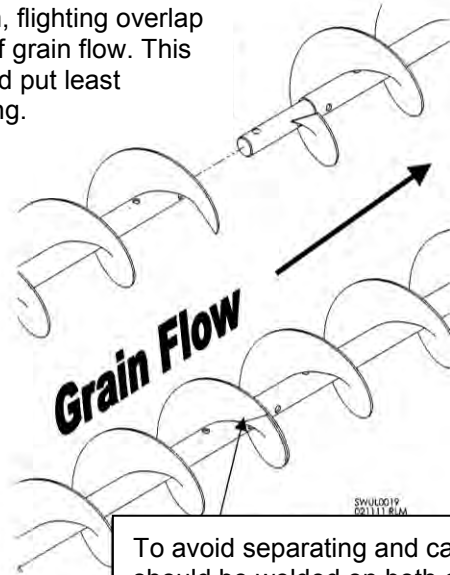

WITHOUT OVERLAP

Using bolts and turning flighting 180°, extension should be lagging, not leading inside section of flighting. If working in rice or other small grains, bolts may be omitted and shaft can be welded into place to match flights. Leave a slight gap between tubes to get a good weld on connecting shaft and tube.

Slide unloading auger, square end first, through unloading tube and over stub shaft in sump. See Fig. 10.

Fig. 10

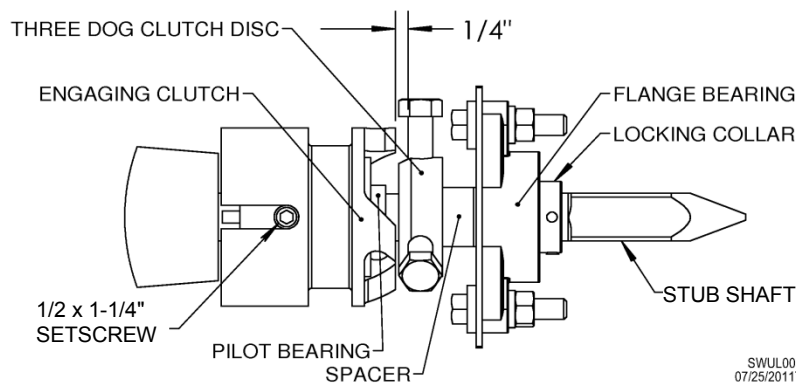

CLUTCH SHOWN IN DISENGAGED POSITION

Installation

Slide bin collar over tube protruding from bin. Position bin collar so clutch pull rod hole and lock assembly are on lower right side as shown in Fig. 11. Collar clamp tabs will be horizontal as shown. Mark clutch rod hole and drill through bin wall. Using metal screws, fasten bin collar to bin wall. Caulk around collar. Do not tighten bin collar clamps at this time. If unload system has an independent intermediate sump, remove knockout for pull rod.

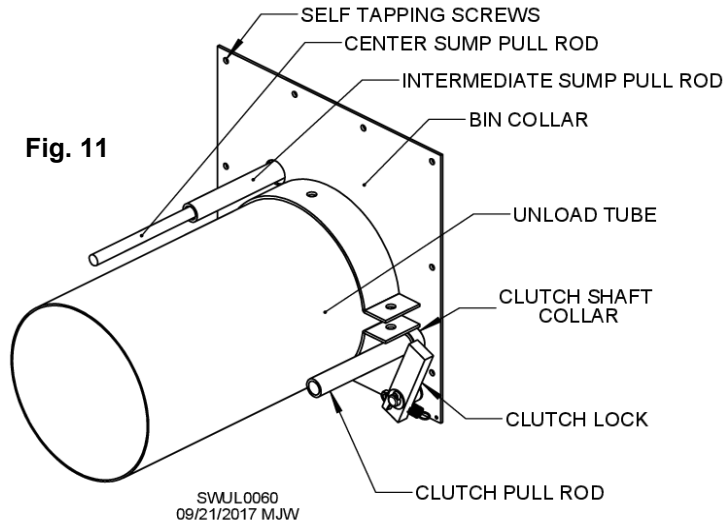

INDEPENDENT INTERMEDIATE SUMP PULL ROD INSTALLATION

Sweepways with 8" or 10" diameter unload tubes manufactured on or after June 1, 2018, are equipped with an independent intermediate sump. Follow these steps to attach pull rod:

1. Remove four (4) shaft collars from pull rod.
2. Attach a pull rod support clamp about 15" from independent intermediate sump. Be sure to leave at least 11" clearance for sump gate opening.
3. In bins more than 31' diameter, attach a second pull rod support clamp about halfway between first clamp and bin wall.
4. Slide pull rod through support clamps and into gate bracket as shown in Fig. 12, simultaneously attaching shaft collars to rod as shown.
5. With gate fully closed, push sump rod against sump.
6. Adjust shaft collars so they are tight against gate bracket. Tighten shaft collars.
7. On outside of bin, attach E5404 handle to pull rod using setscrew.
8. Ensure sump gate opens and closes completely.

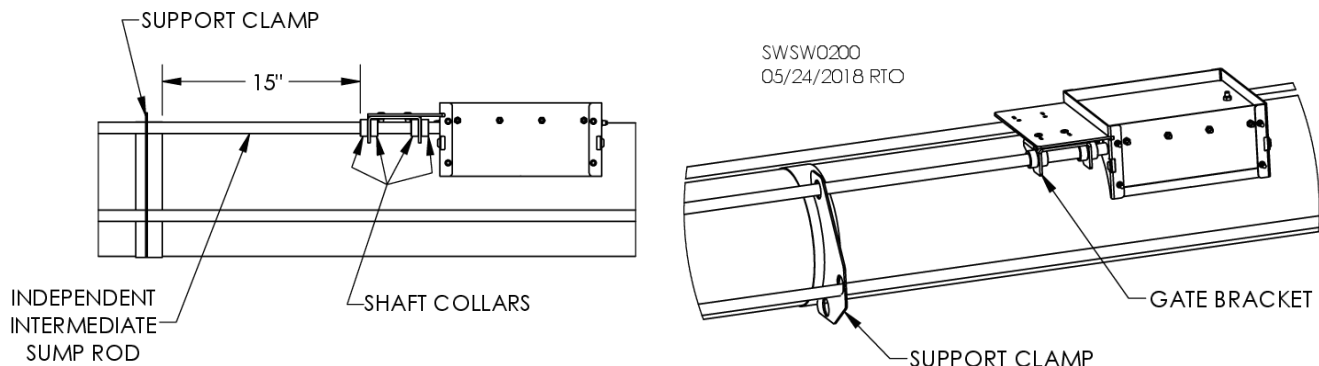

Fig. 12

Installation

Slide clutch pull rod through bin collar and into rear compartment of center sump. If not already installed on unload tube in bin 31' dia. or larger, bolt clutch rod support clamp midway on unload tube and slide clutch pull rod through support (support not needed in smaller bins).

Attach clutch pull rod to clutch shifter arm with 3/8 x 1-1/2" picker pin and hairpin clip. Use hole closest to end of shifter arm for 10" unit. Use other hole for 6" or 8" unit. See Fig. 13. See Fig. 14 for overview of center sump and clutch assembly.

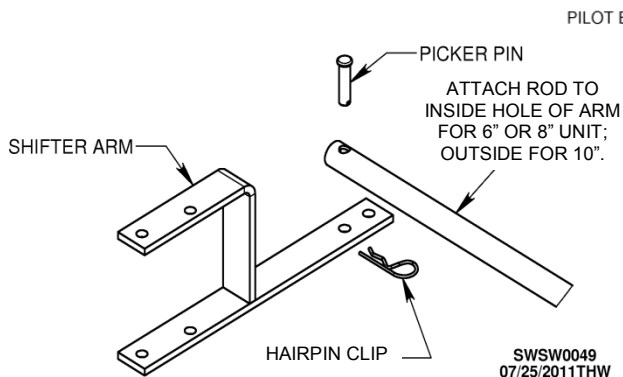

Fig. 13 – Connecting clutch pull rod to shifter arm

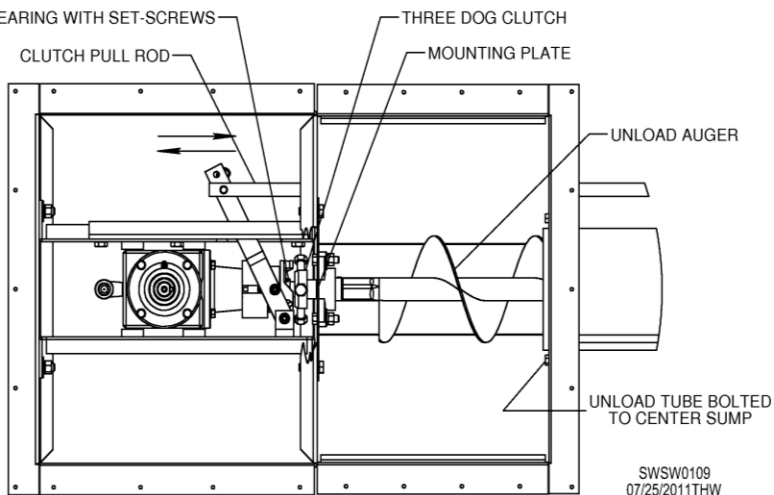

Fig. 14 – Overview of sump w/ pull rod connected

Guide center sump gate pull rod up to 1/2" nut rivet on center sump slide gate. See Fig. 5. Thread pull rod into nut rivet until tight. Turn nut on pull rod until it is tight against slide gate.

As floor installation or re-installation continues, cut floor planks where intermediate sumps will be located. Number of sumps varies with diameter of bin.

Put top half of each intermediate sump into hole cut into bin flooring. Secure flanges to flooring with self-drilling screws. See Fig. 5. Also, ensure bottoms of sump covers extend into intermediate sumps. Sump covers may have to be trimmed so they do not interfere with sump gate operation.

With all intermediate sumps in position and all sump slide gates operating freely, tighten clamps on bin collar. See Fig. 11.

Installation

Slide 1" lock collar onto clutch pull rod with clutch disengaged (rod pushed in). Push latch down and slide 1" lock collar against bin collar so that when latch is released, lock collar is sandwiched between latch and bin collar. See Fig. 15. Tighten 1" lock collar setscrew. Latch will keep clutch disengaged. When latch is pushed down, rod can be pulled for engagement of clutch.

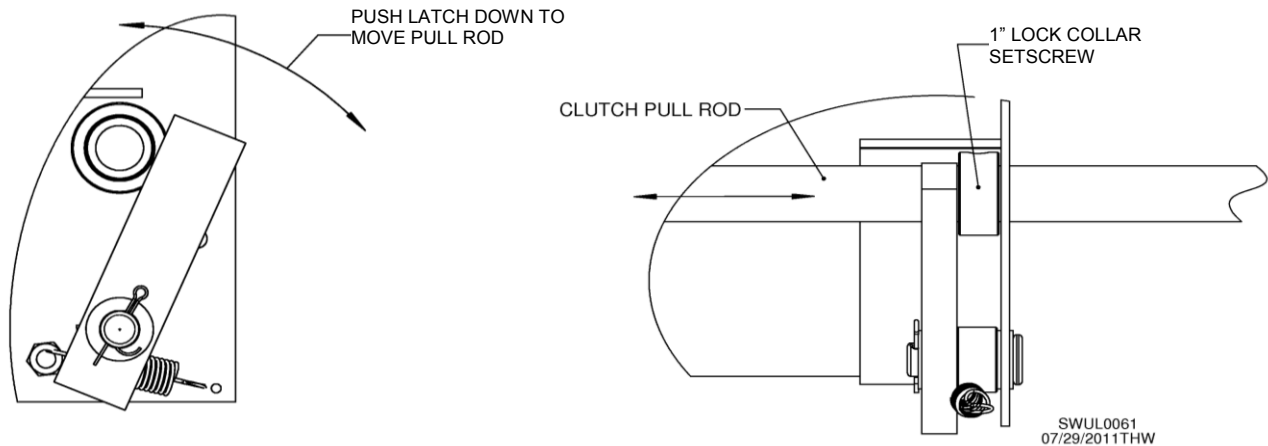

Fig. 15 – Front and side views of clutch lock assembly

NOTE: Clutch is factory-set. However, make sure teeth engage and disengage properly. There should be about 1/4" clearance when clutch is disengaged. See Fig. 10. Clutch disc may be adjusted by loosening bolts.

COMPLETING FLOOR INSTALLATION

Complete installation of bin floor, making sure to provide adequate support along unload tube and near sump. This applies to full-aeration steel floors and flooring over concrete trench.

NOTE: If small, easy-flowing grain will be stored in bin, it is best to seal sumps with silicone or a rubber membrane (not provided) to avoid leaking.

IMPORTANT: Ensure supports do not interfere with sump gate operation.

NOTICE: Floor flashing must be installed over steel aeration floor as shown in Fig. 16 to prevent excessive wear on drive wheel. Sweep moves clockwise. Ensure that flashing is overlaid so sweep wheel "steps up."

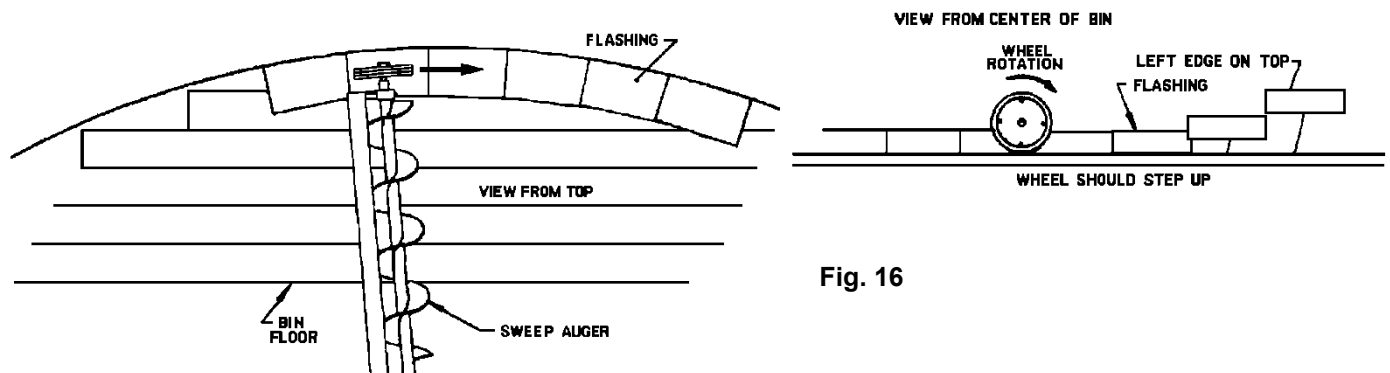

Fig. 16

ASSEMBLING BIN SWEEP

Bring sweep auger and backboard into bin. Bolt sweep auger to gearbox output shaft. See Image 1.

Place spacers on stud bolts in gearbox as shown in Fig. 5 and Image 1. **NOTE:** On units with 6" unload tube, gearbox should be flush with backboard extension; spacers must be installed on backside of backboard extension.

Position backboard extension bracket slots over stud bolts on gearbox and fasten loosely with 7/16" flat washers, lock washers and nuts. See Image 1. Bolt backboard extension bracket to backboard with 3/8" bolts, flat washers, lock washers and nuts, using holes in backboard extension bracket that will position sweep wheel so it will be as close to bin wall as possible without hitting retracted sweep stop.

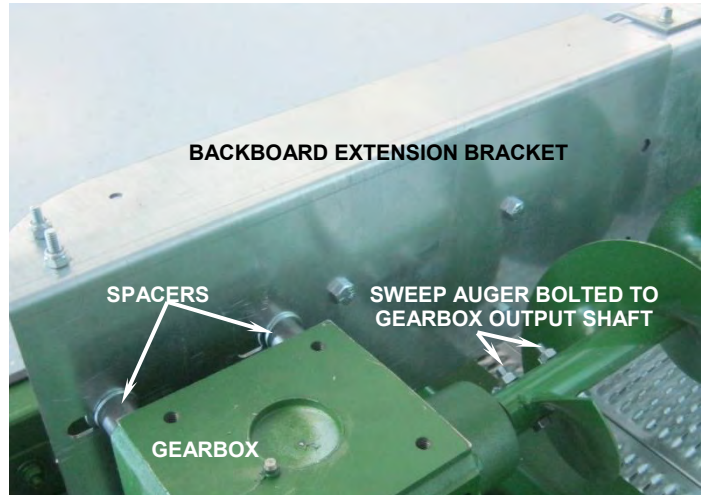
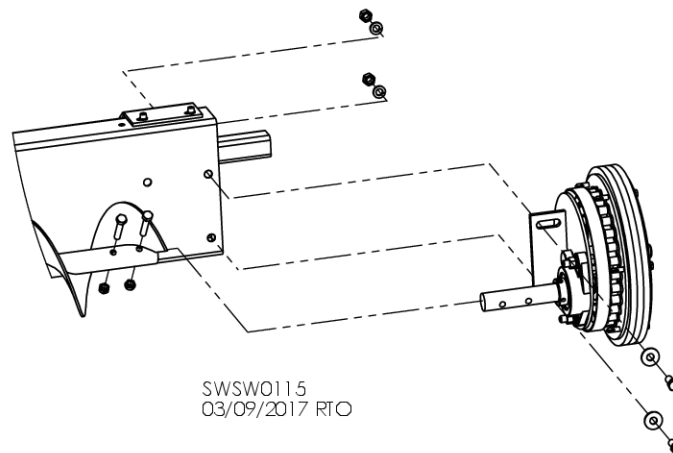

Image 1 – Backboard extension mounted to gearbox, backboard (Gearbox for 8" unload system shown.)

Tighten backboard extension bracket securely to gearbox. **IMPORTANT:** See Fig. 1, Dimension B, to verify approximate distance between floor and backboard.

Size of drive wheel used on sweep depends on size of bin and unload system. A 10" wheel with 4:1 reducer comes standard for all 6" systems and for 8" & 10" systems in bins up to 34' dia. A 17" wheel with 16:1 reducer comes standard for 8" and 10" systems for bins 36' dia. and larger.

For attachment of 10" wheel, see Fig. 17. Loosely bolt sweep auger to reduction wheel input shaft using two 5/16 x 1-3/4" screws (J0570) and two 5/16" lock nuts (J1010). Loosely bolt mounting bracket to sweep backboard using two 3/8 x 1" screws (J0606), 3/8" split lock washers (J1205) and 3/8" hex nuts (J1020) as shown. Position wheel so it is perpendicular with backboard and straight up and down. Tighten bolts connecting shaft to auger, and bolts connecting mounting bracket to backboard.



SWSW0115
03/09/2017 RTO

Fig. 17

Installation

Start attachment of 17" wheel by loosely bolting gearbox input shaft to sweep auger using two 5/16 x 1-3/4" screws (J0570) and two 5/16" lock nuts (J1010). Simultaneously bolt gearbox mounting bracket and backboard reclaim shield to sweep backboard using three 3/8 x 1" screws (J0606), 3/8" split lock washers (J1205) and 3/8" hex nuts (J1020). See Fig. 18.

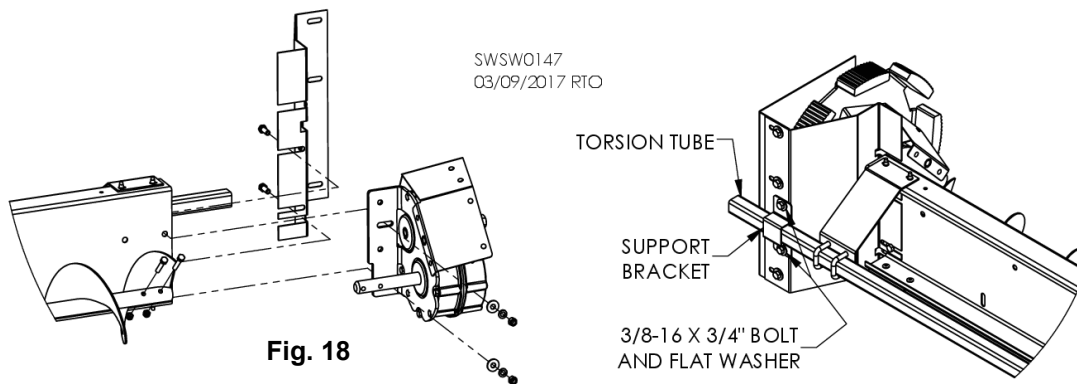

Fig. 18

Remove wheel bolt from gearbox and use it to attach wheel. Adjust gearbox so wheel is not slanted or pitched. Position should be perpendicular to backboard and straight up and down. Tighten bolts connecting gearbox shaft to auger, and bolts connecting gearbox bracket to backboard.

Attach reclaim shield to torsion tube using bracket and 3/8" bolts. See Fig. 18 (Not applicable to 6" units).

Attach backboard reclaim shield extension plate using 3/8" bolts and flat washers as shown in Fig. 18. Adjust in slots so plate is about 1/4" from drive wheel.

Attach rear carrier wheel(s) to backboard as shown on Page 77. In bins 40' dia. and larger, attach one wheel about 3' from center of bin and one about 3' from drive wheel. In smaller bins, attach a single wheel near middle of backboard. **Ensure sumps will be missed by carrier wheel(s).**

ATTACHING SWEEP STOP

Bolt sweep stop to bin wall near door so it can be positioned without entering bin. Bottom of stop must be 1-1/2" from floor. For Sweepway with 17" drive wheel, add sweep stop extension (E5515) as shown in Image 2 using two (2) 5/16" bolts and 5/16" flange nuts.

Mount sweep stop bracket to wall with four (4) 5/16 bolts w/ polyurethane washers, 5/16" fender washers and 5/16" flange nuts. **NOTE:** Flashing bolts can be used to mount bottom of bracket. Holes for top of bracket will have to be field-drilled.

Image 3 shows sweep stop retracted to let sweep pass.

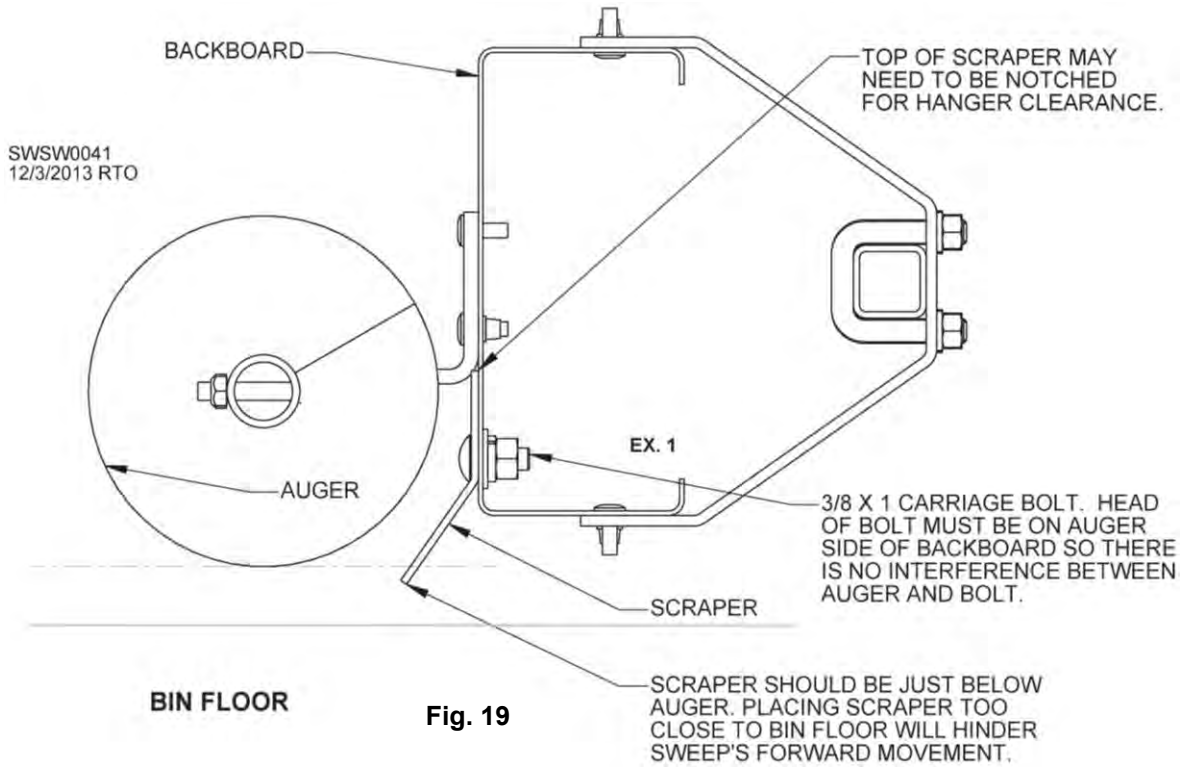

Image 2 – Sweep stop extension added for use with 17" drive wheel



Image 3 – Sweep stop retracted

BACKBOARD SCRAPER INSTALLATION



1. Start at drive wheel end of backboard. See Fig. 20, EX. 3. Place scraper's short side flat against backboard. See Fig. 19. Align scraper holes with slots in backboard. See Fig. 20, EX. 3. Attach using 3/8 x 1" carriage bolts, flat washers, lock washers and nuts. See Fig. 19. **NOTE:** Top of scraper may need to be notched to avoid interference with auger bracket.

NOTE: SCRAPERS HAVE TWO SETS OF HOLES. ATTACH EACH SCRAPER USING HOLES THAT PROVIDE DESIRED CLEARANCE FROM FLOOR.

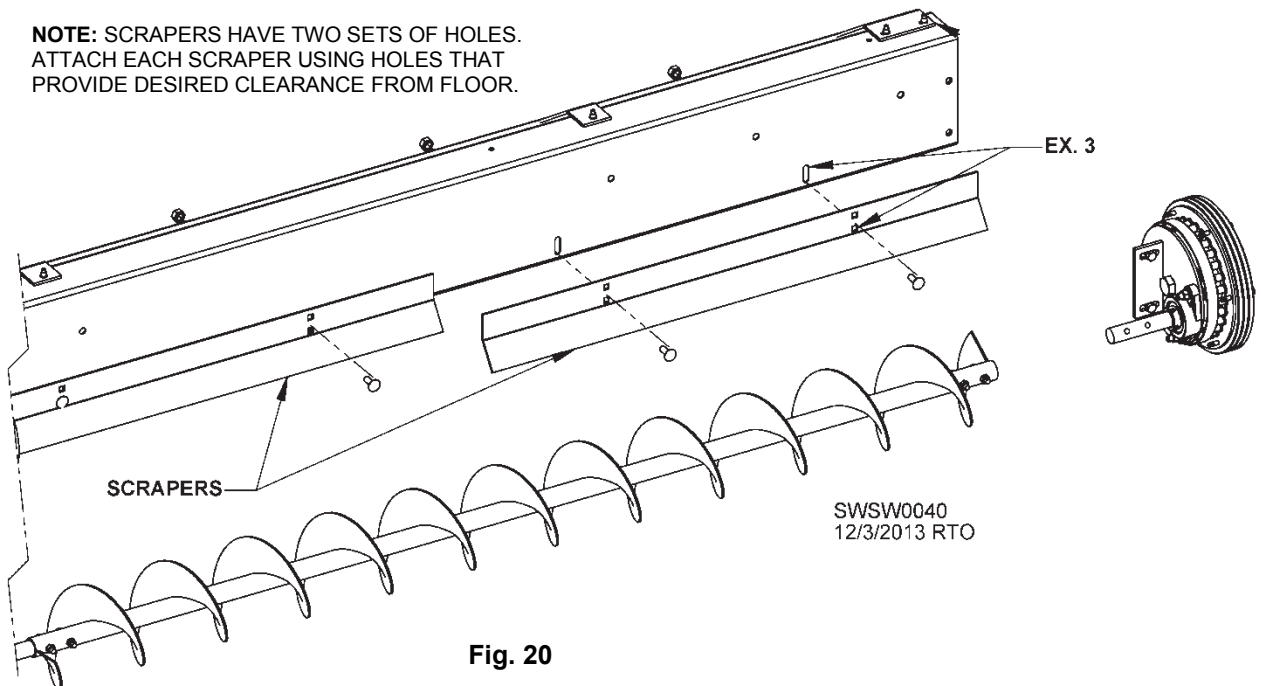

Installation

2. Attach scrapers to backboard using 3/8 x 1" carriage bolts, with heads of bolts on auger side of backboard See Fig. 19. Use flat washers, lock washers and nuts on backside of backboard. Adjust scraper sections so bottoms are just below auger as shown in Fig. 19. Tighten bolts. **NOTE:** Setting scraper too low will limit forward travel of sweep auger and reduce unload capacity.
3. Continue attaching scraper sections on backboard until all are installed or until all visible slots in backboard have been filled. If scraper hits center attachment bracket, scraper will need to be cut. **DO NOT CUT BACKBOARD ATTACHMENT BRACKET.** Scraper closest to gearbox may only be 18" long depending on bin diameter. All scraper sections provided may not be used.
4. Once all scrapers and all other equipment for bin have been installed, exit bin and engage sweep auger. Start unload system and allow sweep to make one complete revolution in bin to make sure there is nothing on floor that will catch on scrapers.



DANGER: KEEP AWAY when auger is running. Entanglement with rotating auger will cause death or serious injury.

5. If scrapers catch on anything, stop unload system and remove obstacle. If it cannot be removed, raise scraper section that was hitting obstacle until it clears. Back auger up a couple feet, **exit bin** and resume test.
6. Once scrapers are adjusted so auger can make its revolution in bin freely, shut power off and make sure scrapers sections are tight. Once bin has been filled, floor and sweep may flex due to weight of grain. It may be necessary to adjust scrapers again. Make sure sweep auger is positioned just behind intermediate sumps.

CLUSTER BUSTER INSTALLATION



Image 4 – Cluster Buster installed

Cluster Buster kits are available for bins 15' to 61' 10" in diameter. Kit E7975 is for sweeps in bins with a 6" or 8" diameter unload tube. Kit E7976 is for sweeps in bins with a 10" diameter unload tube. Installation process is same for both kits.

Determine location for hole in side of bin. Position sweep auger just behind outermost intermediate sump (to left of sump when looking toward bin wall). Note location of backboard torsion bar and drill 1" dia. hole in bin wall that will line up with torsion bar. See Image 5.

Insert end of 1" OD bent conduit (E7968 or E7969) into torsion bar and attach other end to backboard using U-bolt (J08107). See Images 4 and 6 and Fig. 22. Ensure end of conduit is even with end of backboard. Holes for U-bolt may need to be field-drilled.

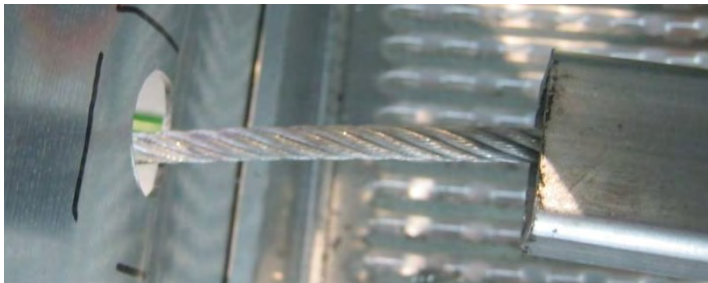

Image 5 – Hole aligned with torsion bar



Image 6 – Conduit mounted on sweep backboard

Insert 1/4" cable (not provided) through hole in bin and push through torsion bar and conduit so cable extends about 15" from conduit. See sticker L0913 for recommended cable length. Leave enough cable outside of bin to attach drill. Mark cable at bin wall to serve as a guide for when other end is over sump. Use torch to weld end strands of cable together to prevent fraying. See Image 7. Welding cable will help ease its transition from torsion bar to conduit.

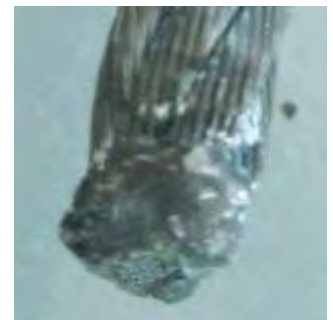

Image 7 – Welded cable

Installation



Image 8 – Alignment rod in torsion bar

Remove cable from bin and insert rod through bin wall hole and into torsion bar. See Image 8. Press down on handle as shown in Image 9 to seal rubber grommet in hole. If seal is not tight, remove rod and turn rubber grommet counterclockwise while holding handle stationary to increase grommet diameter. Reinsert and check seal again. Repeat as needed.



Image 9 – Rod/plug handle outside of bin



Image 10 – Rod kept inside of bin door

Affix Cluster Buster operation sticker to inside of bin door near bolt where rod will hang when not in use.

TO OPERATE: From outside of bin, remove alignment rod and insert 1/4" cable through torsion bar and conduit. Push cable until it comes into contact with grain over sump.

Attach variable-speed drill to cable and turn drill on. Push spinning cable in and out until clog is broken up and grain is moving. **NOTE:** If cable does not turn when drill is activated, pull back slightly.

NOTICE: Before engaging sweep, make sure neither cable nor rod is in torsion bar.

When bin is empty, line up torsion bar with hole in bin wall. Slide rod into torsion bar from outside of bin and snap down handle to plug hole.

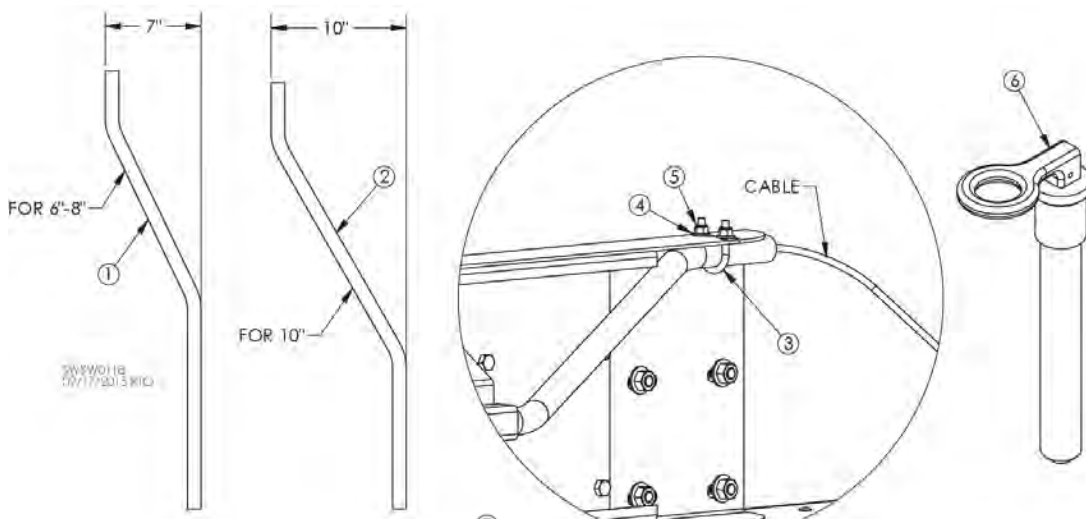

Fig. 22 & Table 11

BIN DIAMETER	1/4" DIAMETER CABLE LENGTH
24'	13' 8"
24' 9"	14' 1"
26' 3" (8M)	14' 10"
27'	15' 2"
27' 10"	15' 7"
29' 6" (9M)	16' 5"
30'	16' 8"
31'	17' 2"
33'	18' 2"
34'	18' 8"
36' (11M)	19' 8"
37' 1"	20' 3"
42'	22' 8"
42' 8" (13M)	23'
43' 3"	13' 4"
48'	25' 8"
49' 3" (15M)	26' 4"
54'	28' 8"
55' 8"	29' 6"
60'	31' 8"
61' 10"	32' 7"

CLUSTER BUSTER

PRIOR TO OPERATION: Obtain 1/4" diameter cable at approximate length shown in table. (For other bin sizes approximate length can be obtained by bin radius +20") Using a torch, fuse ends of cable into a solid ball.

TO OPERATE: From outside of bin, remove alignment rod and insert 1/4" cable through torsion bar and conduit. Push cable until it comes into contact with grain over sump. Attach variable-speed drill and turn it on. Push spinning cable in and out until clog is broken up and grain is moving. **NOTE:** If cable does not turn when drill is activated, pull back slightly.

IMPORTANT: Before engaging sweep, make sure neither cable nor rod are in torsion bar.

When bin is empty, line up torsion bar with hole in bin wall and slide rod into torsion bar from outside of bin.

ITEM #	DESCRIPTION	QTY.	COMP. #
1	Conduit for 6" or 8" Sweepway	1	E7968
2	Conduit for 10" Sweepway	1	E7969
3	U-bolt	1	J08107
4	Flat washer, 1/4"	2	J1105
5	Nut, 1/4" – 20	2	J0992
6	Alignment rod	1	E7985
7	Sticker	1	L0913

Sukup Manufacturing Co., Sheffield, IA, USA 50475 L0913

SWEEPWAY POWERHEAD OPTIONS

See Page 32 to determine which knockouts to remove from inner belt shield.

Horizontal with Single Motor Drive

To aid in part identification during assembly, please see Pages 44-45.

1. Slide connector sleeve onto unloading tube and loosely attach with 3/8 x 3" bolts, lock washers and nuts. See Pages 34-36 for instructions on installation of sump openers.
2. Remove safety shield sections (6, 8) and brackets (7) from powerhead assembly. Slide powerhead tube into connector sleeve so unload auger shaft protrudes through flange bearing (9). Slide powerhead on completely so that it contacts unloading tube.
3. Rotate powerhead assembly to level position and tighten bolts on connector sleeve.
4. Slide locking collar (26) over auger shaft protruding from unloading tube and lock onto flange bearing. Tighten setscrew on locking collar.
5. Mount 3.4" motor pulley onto motor shaft. Secure with key and setscrew.
6. Mount motor onto motor mount plate (4) with 3/8 x 1-1/2" bolts, nuts, lock washers and flat washers.
7. Re-attach brackets (7) and inner shield (8).
8. Attach pulley (25) to shaft extending from unload tube. Place 1/4" key (27) in slot on pulley and align with motor pulley. Tighten setscrew.
9. Place belts (28) on pulleys. Tension may be adjusted by tightening bolt on bottom motor mount plate. See belt-adjusting instructions on Page 33.
10. Place outer safety shield (6) over pulley and tighten bolts. **KEEP SHIELD IN PLACE AT ALL TIMES!**

Installation

Basic Vertical Auger

To aid in part identification during assembly, please see Pages 46-47.

1. Slide connector sleeve (13) halfway onto unloading tube. Loosely bolt with 3/8 x 3" bolts, lock washers and nuts. See Pages 34-36 for instructions on installation of sump openers.
2. Remove safety shield assembly from vertical auger boot.
3. Slide boot into sleeve (13) positioned on under-bin unloading tube so it contacts under-bin unloading tube. Slide unloading auger shaft through flange bearing of boot while sliding tube together. Boot should be tight against under-bin unload tube. Rotate boot to right for assembly of vertical auger.
4. Slide second connector sleeve (13) halfway up vertical tube of boot. Loosely bolt in place with 3/8 x 3" bolts, nuts and lock washers.
5. Slide vertical auger flighting (23) (double flighting at bottom) through boot so that bottom shaft extends through bearing on bottom of boot.
6. Slide tube (15) over flighting into second connector sleeve so that tube contacts boot. Tighten connector sleeve.
7. Attach third connector sleeve (13) to top half of tube (15). Loosely bolt in place.
8. Slide top spout (11) over flighting while sliding top auger shaft (2) through top bearing (4) into connector sleeve so that top spout contacts tube. Rotate spout to desired unloading direction and tighten connector sleeve.
9. Place locking collar (22) over top shaft (2). Drive 5/16 x 1-3/4" rollpin (1) through hole in shaft just above bearing and collar. Check to be sure rollpin rests against locking collar. Lock locking collar on flange bearing and tighten setscrew on locking collar.
10. Slide second locking collar onto shaft protruding from bearing end plate (Not shown) at bottom of vertical auger and lock in place on flange bearing. Tighten setscrew.
11. Bolt 2-1/2' truck spout (12) onto top spout (11) using 3/8 x 1-1/2" bolts, nuts and lock washers.
12. Using crane, raise vertical auger into position. Provide temporary blocking under boot. Clamp support bracket(s) around vertical auger.
13. Tighten bottom, horizontal connector sleeve.
14. Adjust threaded support jack bolt on boot to carry load of vertical auger. Remove temporary blocking under auger. Check to see that tube and auger are aligned.
15. Using existing bin bolts, attach support brackets (14) to bin wall about 10' up on vertical tube. If bin has outside stiffeners, attach brackets to stiffeners (holes may need to be drilled). Adjust and secure legs of support brackets.
16. Slide locking collar over unloading shaft from horizontal auger. Lock in place on flange bearing. Tighten setscrew.
17. Ensure all safety shields are in place and bolts are tight. **NOTE:** Safety shield brackets and inner shields must be installed before pulleys.

Installation

Two Motor Drive (Standard Equipment)

To aid in part identification during assembly, please see Pages 48-49.

1. Follow Steps 1-17 in Basic Vertical Auger Assembly Instructions.
2. Mount motor (motor and motor pulley not included) onto horizontal motor mount using four 3/8 x 1-1/2" bolts, lock washers, flat washers and nuts. Motor uses 3.4" motor pulley.
3. Reinstall brackets and inner shield section.
4. Mount large pulley onto horizontal shaft. Place 1/4" key in slot of pulley. Align pulley with motor pulley. Tighten setscrews.
5. Install belts provided and tighten to proper tension by adjusting bolt under horizontal motor mount. See belt-adjusting instructions on Page 33.
6. Mount 3.4" motor pulley onto vertical motor. Mount motor to vertical motor mount plate, using four 3/8 x 1-1/2" bolts, nuts, washers and flat washers.

NOTE: Shields for vertical auger are attached upside-down at factory to avoid damage during shipping. They must be rotated 180° during field installation.

7. Mount 9" pulley onto bottom vertical shaft. Place 1/4" key in slot of pulley. Align with motor pulley and tighten setscrews.
8. Install belt(s) onto pulleys and adjust to proper tension. See belt-adjusting instructions on Page 33.
9. Ensure all safety shields are in place and bolts are tight.

One Motor Drive (Optional Equipment)

To aid in part identification during assembly, please see Pages 49-50.

1. Follow Steps 1-17 in Basic Vertical Auger Assembly Instructions.
2. Slide large pulley (35) onto shaft extending from horizontal unload tube with hub side of pulley out. Place 1/4" key (36) in slot on pulley.
3. Slide 50B15 sprocket (62) on shaft protruding from horizontal unload tube with hub side away from pulley.
4. Slide 50B15 sprockets (56) on each shaft of gearbox and on bottom shaft of vertical auger. Place 1/4" key in slots of all sprockets and align. Tighten setscrews.
5. Place short #50 chain and connector link on sprocket on bottom of gearbox and sprocket on bottom of vertical auger. Chain can be tightened by adjusting gearbox mounting bolts. Align.
6. Mount motor onto mounting plate (11) with 3/8 x 1-1/4" bolts, nuts, washers, and flat washers. Mount 3.4" motor pulley. Align pulleys and tighten setscrews. Place belts (39) on pulleys and adjust tension by adjusting under motor mount plate. See belt-adjusting instructions on Page 33.
7. Place long #60 chain and connector link on sprocket on front of gearbox and on sprocket on end of horizontal unload tube. Adjust tension by raising or lowering idler sprocket (64). Align.
8. Ensure all safety shields are in place and bolts are tight.

Installation

Top Drive

To aid in part identification during assembly, please see Pages 52-53.

1. Slide first of three connector sleeves (40) halfway onto horizontal unloading tube. Loosely bolt connector sleeve with 3/8 x 3" bolts, nuts and lock washers.
2. Remove safety shields (48, 47) and shield brackets (46) from vertical auger boot.
3. Slide boot into sleeve (40), positioning on unloading tube so it contacts under-bin unload auger. Slide unloading auger shaft through flange bearing of boot while sliding tube together. Boot should be tight against under-bin unload tube. Rotate boot to right for assembly of vertical auger.
4. Slide second connector sleeve halfway up vertical tube of boot. Loosely bolt in place with 3/8 x 3" bolts, nuts and lock washers.
5. Slide vertical flighting (double flighting at bottom) through boot so that bottom shaft extends through bearing on bottom of boot.
6. Slide tube (39) over flighting into second connector sleeve so tube contacts boot. Tighten sleeve.
7. Attach third connector sleeve (40) to top half of tube in same manner as previous connector sleeves. Loosely bolt in place.
8. Slide top spout (1) over flighting while sliding auger shaft through top bearing (4) into connector sleeve so that top spout is against tube. Rotate spout to desired unloading direction and tighten third connector sleeve.
9. Place locking collar (5) over top shaft (31). Add spacer (37). Mount pulley (9) on shaft. Drive 5/16 x 1-3/4" rollpin (11) through hole in shaft just above pulley. Check to be sure rollpin rests against pulley. Lock locking collar in place on flange bearing (4). Tighten setscrew.
10. Slide second locking collar (5) onto shaft protruding from bottom bearing end plate (Not shown) of vertical auger and lock in place on flange bearing. Tighten setscrew.
11. Bolt 2-1/2' truck spout (43) onto top spout using 3/8 x 1-1/2" bolts, nuts and lock washers.
12. Using existing bin bolts, attach support bracket (42) to bin wall about 10' up on vertical tube.
13. Using crane, raise vertical auger into position. Provide temporary blocking under boot. Clamp support bracket around vertical auger.
14. Tighten bottom, horizontal connector sleeve.
15. Adjust threaded support jack bolt on boot to carry load of vertical auger. Remove temporary blocking under auger. Check to see that tube and auger are aligned.
16. Adjust and secure legs of support bracket.
17. Slide third locking collar over unloading shaft from bearing. Tighten setscrew.
18. Remove motor mount and bolt to motor using four 3/8 x 1-1/2" bolts, flat washers and lock washers. Re-attach motor mount.
19. Re-attach safety shield brackets and inner shields.
20. Align pulley (9) with motor pulley. Insert 1/4" key in key slot and tighten setscrew.
21. Place belts (23) onto pulleys and tighten using motor mount adjustment bolt. Belt tension should be as low as possible without allowing belts to slip. See belt-adjusting instructions on Page 33.
22. Recheck belt tension before operation. Replace outer section of safety shields. NEVER OPERATE UNIT WITHOUT SAFETY SHIELDS SECURELY IN PLACE. Make sure all safety decals have been installed and are legible. See safety section for correct locations and descriptions of safety decals.

Installation

Incline

To aid in part identification during assembly, please see Pages 54-55.

NOTE: Instructions below use part reference numbers for 25° incline. Follow same steps to install 20° incline. Reference numbers will be different. See Pages 56-57 for drawings and parts list for 20° incline.

1. Remove motor mount (6), shield sections (13, 14) and shield brackets (15) from top of incline.

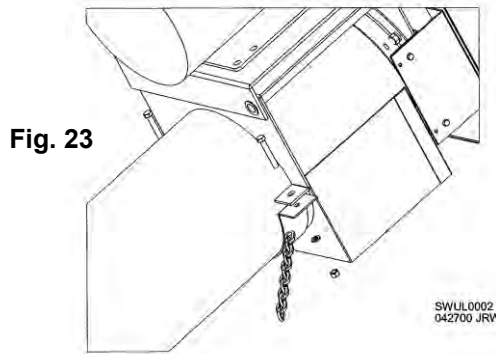

INSTALL EYEBOLT WITH ONE NUT COMPLETELY THREADED BEFORE PUTTING IN BIN WALL. START SECOND NUT ON EYEBOLT. LEAVING ROOM TO TAKE UP SLACK IN CHAIN

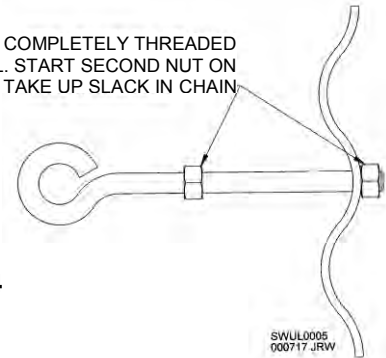

2. Remove bolts holding tube mount (10) to incline tube (1). Connect one end of each support chain to each side of tube mount. See Fig. 23. Tighten bolts.

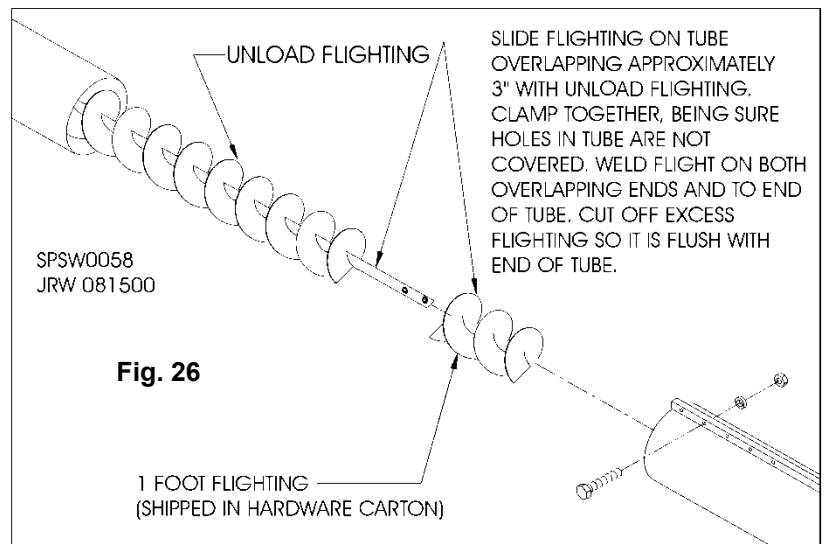
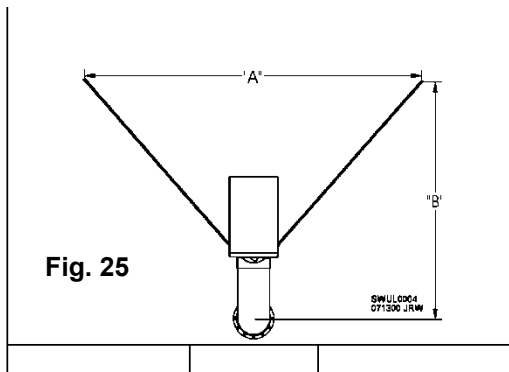

3. Remove two bin bolts spaced equidistant from unload tube ("A" = 80-100") along seam between second and third rings of bin sheets ("B" = 60-80"). See Fig. 26.
4. Remove shaft and corn flipper from end of unload auger. **NOTE:** Keep fasteners. They will be used later. Weld a 1' piece of flighting to unload flighting. See Fig. 26.
5. Slide connector sleeve (19) halfway over end of unload tube.
6. Slide adapter sleeve (17) into open end of connector sleeve.
7. Loosely install six 3/8 x 3" bolts (29) and nuts (34) on connector sleeve.
8. Rotate adapter sleeve to match hole pattern of angle ring on incline (1).
9. Tighten all bolts on connector sleeve.

Installation

10. Attach adapter plate (16) to adapter sleeve using 5/16 x 1-1/4" bolts (26), flat washers (39), lock washers (40) and nuts (33).
11. After sliding horizontal unload flighting out to attach to incline, temporarily support incline. Slide horizontal shaft (3) into horizontal flighting and bolt into place using two 7/16 x 2" bolts. Use bolts from Step 4. Slide unload auger back into under-bin tube along with incline tube and flighting. If installing with a powersweep, make sure unload auger slides onto drive shaft in center sump.
12. Bolt incline (1) to adapter plate (16) using 5/16 x 1-1/4" bolts (26), flat washers (39), lock washers (40), and nuts (33).
13. Attach chain to eyebolts and tighten nuts on inside of bin to tighten chains. See Fig. 24.
14. Bolt motor to motor mount (6) using four 3/8 x 1-1/2" bolts, flat washers, and lock washers. Re-attach motor mount to tube mount (10).
15. Re-attach shield brackets (15) and inner shield (14) to tube mount (10).
16. Attach 14" pulley (23) to power shaft (4) extending from top of powerhead. Align pulley with motor pulley. Insert 1/4" key (18) in key slot and tighten setscrew in pulley (23).
17. Place belts (22) onto pulleys and tighten using motor mount adjustment bolt (32). Belt tension should be as low as possible without allowing belts to slip. See belt-adjusting instructions on Page 33.
18. Recheck belt tension before operation. Re-attach outer section of safety shield (13). **NEVER OPERATE UNIT WITHOUT SAFETY SHIELDS SECURELY IN PLACE.** Make sure all safety decals have been installed and are legible. See safety section in this manual for correct locations and descriptions of safety decals.

INNER BELT SHIELD INSTALLATION GUIDE

Use drawing and table below to determine which knockout panel(s) must be removed from inner section of belt shield to accommodate motor shaft, depending on discharge powerhead and motor size.

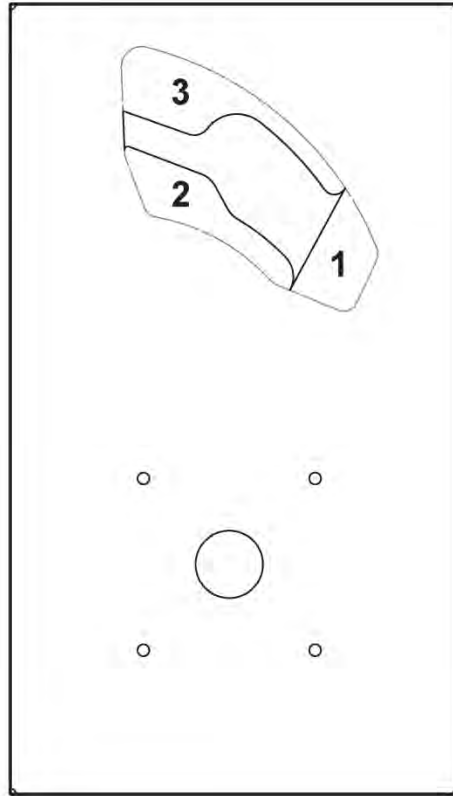

Fig. 27 & Table 11

POWERHEAD	MOTOR SIZE (HP)								
	1	2 (F145T)	2 (E182T)	3	5	7.5	10	15	20
HORZ. 6"	1	1	2	2	2	2	2	N/A	N/A
HORZ. 8"	1	1	2	2	2	2	2	2	2
HORZ. 10"	1	1	2	2	2	2	2	2	2
INCLINE 6"-8"	1	1	2	2	2	2	2	N/A	N/A
INCLINE 8"-10"	1	1	2	2	2	2	2	3	3
INCLINE, 10"-12"	None	None	3	3	3	3	3	3	3
VERT. 6" (2 MTR)	1	1	2	2	2	2	2	2	2
VERT. 8" (2 MTR)	1	1	2	2	2	2	2	2	2
VERT. 10" (2 MTR)	1	1	2	2	2	2	2	3	3
TRANSFER 6"	1	1	2	2	2	2	2	N/A	N/A
TRANSFER 8"	1	1	2	2	2	2	2	N/A	N/A
TRANSFER 10"	1	1	2	2	2	2	2	N/A	N/A
TOP DRIVE 6"	1	1	2	2	2	2	2	N/A	N/A
TOP DRIVE 8"	1	1	2	2	2	2	2	N/A	N/A

ADJUSTING BELT TENSION

Place belt(s) in sheave grooves and tighten by adjusting motor mount. Follow these steps to tension belt.

1. Measure span length. See Fig. 28.
2. At center of span, apply enough force to deflect belt 1/64" for every 1" of belt span. If span is 32", deflection amount should be 32/64", or 1/2".
3. Use Table 12 to determine amount of force to apply to gauge proper deflection per belt.

Belt Cross Section	Smallest Pulley Diameter Range	RPM Range	Belt Deflection Setting			
			Deflection = 1/64 of belt span			
			Uncogged Single V-Belts & Uncogged Banded V-Belts		Cogged V-Belts & Cogged Banded V-Belts	
			Used Belt	New Belt	Used Belt	New Belt
A, AX	3.0 – 3.6"	1,000 – 2,500	3.6	5.4	4.0	6.0
		2,501 – 4,000	2.8	4.1	3.3	4.9
	3.8 – 4.8"	1,000 – 2,500	4.4	6.6	4.9	7.3
		2,501 – 4,000	3.7	5.7	4.3	6.4
	5.0 – 7.0"	1,000 – 2,500	5.3	7.8	5.7	9.2
		2,501 – 4,000	4.6	6.8	5.1	7.6
B, BX	3.4 – 4.2"	860 – 2,500	---	---	4.8	7.2
		2,501 – 4,000	---	---	4.1	6.2
	4.4 – 5.6"	860 – 2,500	5.2	7.9	7.1	10.5
		2,501 – 4,000	4.5	6.6	7.1	9.1
	5.8 – 8.6"	860 – 2,500	6.2	9.4	8.4	12.4
		2,501 – 4,000	6.0	6.8	7.3	10.7
5V, 5VX	4.4 – 6.7"	500 – 1,749	---	---	10	15.2
		1,750 – 3,000	---	---	8.9	13.2
		3001 – 4000	---	---	5.6	8.5
	7.1 – 10.9"	500 – 1,740	12.6	18.9	14.8	22.1
		1,741 – 3,000	11.2	16.5	13.7	20.1
	11.8 – 16.0"	500 – 1,740	15.5	23.4	17.1	25.5
1,741 – 3,000		14.5	21.8	16.8	25	

Table 12 – Belt deflection settings for Bestorq belts

Sukup products use belts made by Bestorq. Sukup recommends using a Bestorq tension meter to measure belt deflection. Go to www.bestorq.com or call (402) 423-3077 for more information.

After adjusting tension to desired level by adjusting motor mount, remove any foreign material from inside of belt guard. Check that all fasteners are tightly secured. Close and latch belt guard.

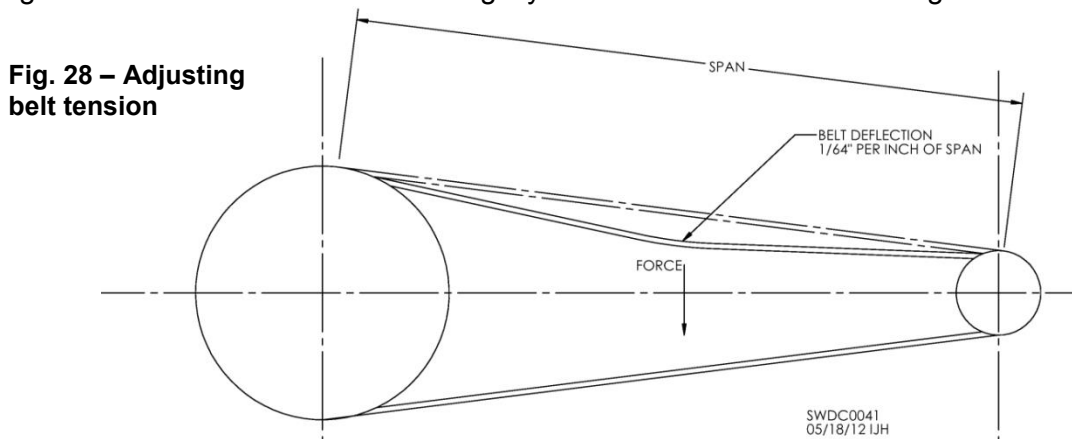

IMPORTANT: Check and adjust belt tension after first five (5) and 24 hours of operation, then during regular maintenance (at least twice yearly).

SUMP OPENER FOR 6" SWEEPWAY

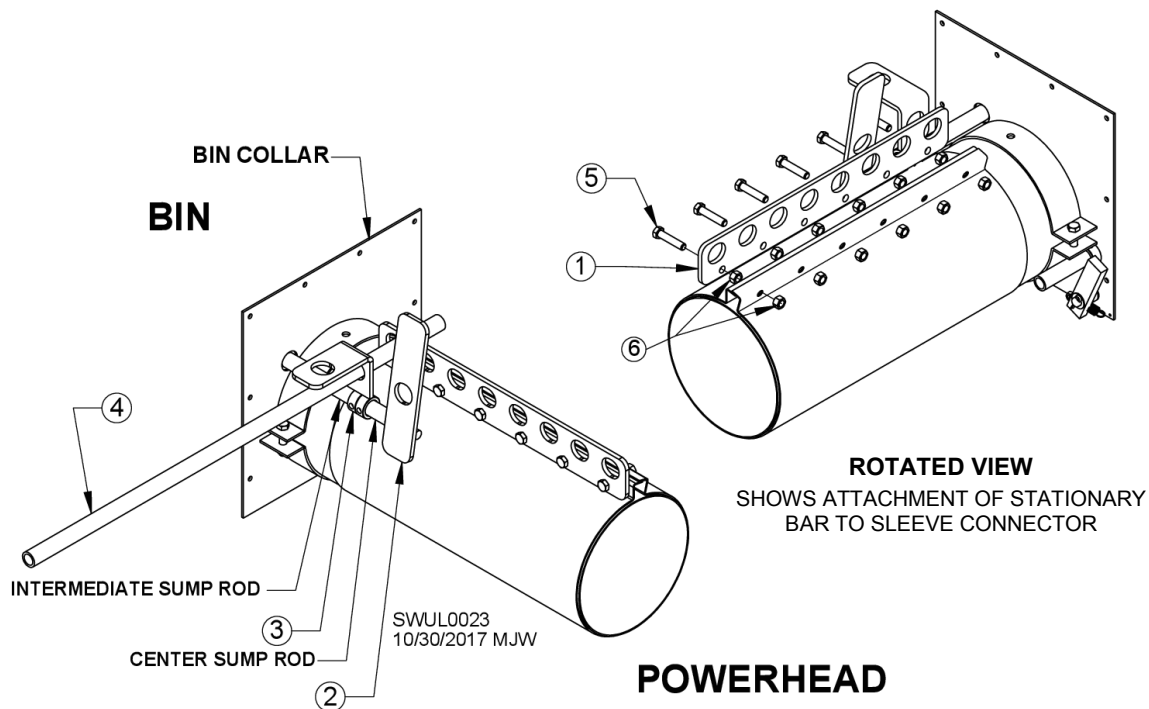

Fig. 29 & Table 13

REF. #	DESCRIPTION	QTY.	6" COMP. #
	Complete pull rod opener assembly	1	E5432
1	Stationary bar	1	E5884
2	Center sump opener handle	1	E5889
3	Intermediate sump opener L handle	1	E5888
4	Lever arm	1	E5885
5	Bolt, 3/8 - 16 x 3", PLT, GR5	6	J0660
6	Hex nut, 3/8" -16, PLT	12	J1020

Installation instructions:

1. With sumps fully closed, attach center sump opener "L" handle (2) to center sump pull rod using setscrews in shaft collars, and attach intermediate sump opener "L" handle (3) to intermediate sump pull rod using setscrews in shaft collars.
2. Attach stationary bar (1) to connector sleeve using 3/8" bolts (5) and two rows of 3/8" nuts (6) as shown in Fig. 29.
3. Slide connector sleeve as needed to line up innermost hole in stationary bar with hole in intermediate sump opener "L" handle (3). Tighten hardware.

Open sump gates by sliding lever arm (4) through hole in opener handle and hole in stationary bar. Pull arm away from bin to open sump(s) and push arm toward bin to close sump(s). Use other pry holes in stationary bar as needed.

IMPORTANT: Always open and unload from center sump first. Never open intermediate sumps until grain stops flowing from center sump.

SUMP OPENER FOR 8" SWEEPWAY

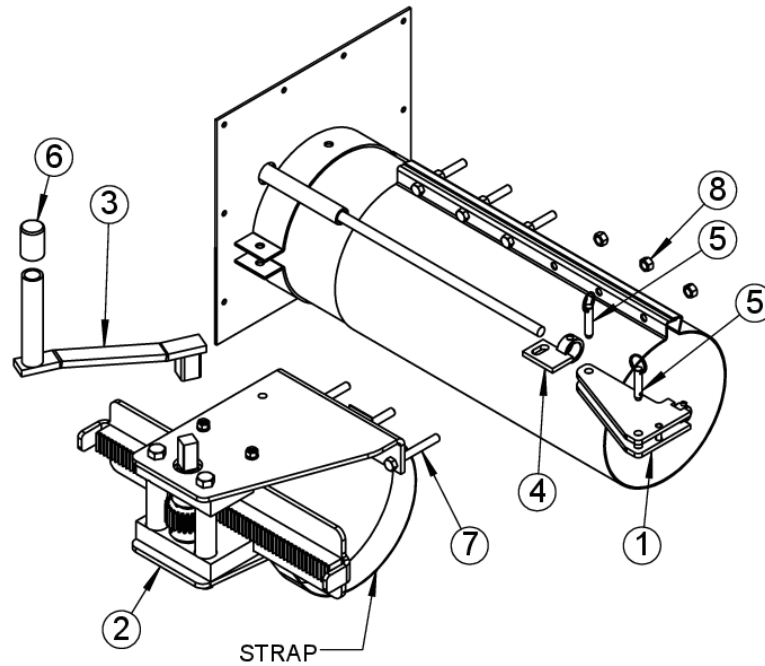

Fig. 30 & Table 14

SWUL0042
09/21/2017 MJW

REF. #	DESCRIPTION	QTY.	8" COMP. #
	Complete rack & pinion opener assembly	1	E5443
1	Center sump connector	1	E5914
2	Rack & pinion opener assy., 8"	1	E5919
3	Opener handle	1	E5967
4	Intermediate sump connector	1	E5998
5	Quick-release pin, 3/8 x 1"	2	J1554
6	Rubber cap, 1"	1	J2232
7	Screw, 3/8 - 16 x 3", PLT, GR5	6	J0660
8	Hex nut, 3/8" - 16, PLT	6	J1020

Installation instructions:

1. With sumps fully closed, loosely attach intermediate sump and center sump connectors (4 & 1) to proper pull rod.
2. Bolt rack and pinion opener assembly (2) to sleeve connector using three bolt holes farthest from bin wall.
3. Attach center sump connector (1) to rack & pinion opener using a 3/8 x 1" quick release pin (5).
4. Attach rubber cap (6) to handle (3) and attach handle to opener.
5. Make sure sump gates are completely closed and then attach connectors to one another using a 3/8" x 1" quick-release pin (5).
6. Tighten setscrews in shaft collars.

Open sump gates by rotating handle clockwise. Sump gates should open and close fully.

IMPORTANT: Always open and unload from center sump first. Never open intermediate sumps until grain stops flowing from center sump.

SUMP OPENER FOR 10" SWEEPWAY

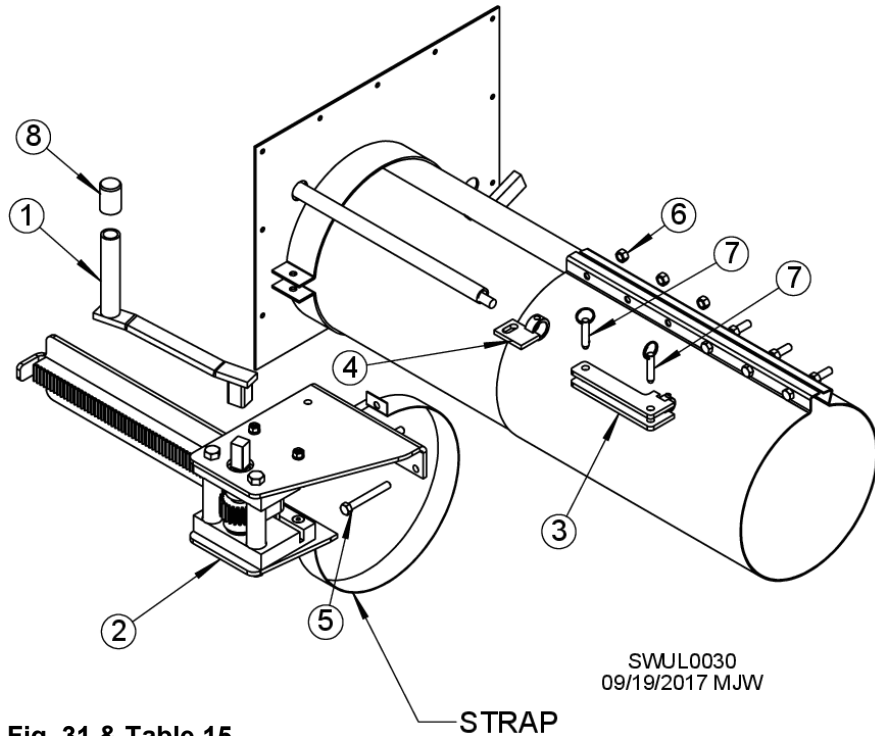

Fig. 31 & Table 15

REF. #	DESCRIPTION	QTY.	10" COMP. #
	Complete rack & pinion opener assembly	1	E5444
1	Opener handle	1	E5967
2	Rack & pinion opener assembly, 10"	1	E5969
3	Center sump connector	1	E5997
4	Intermediate sump connector	1	E5998
5	Bolt, 3/8 - 16 x 3", PLT, GR5	6	J0660
6	Hex nut, 3/8" - 16, PLT	6	J1020
7	Quick-release pin, 3/8 x 1"	2	J1554
8	Rubber cap, 1"	1	J2232

Installation instructions:

1. With sumps fully closed, loosely attach intermediate sump and center sump connectors (4 & 3) to proper pull rod.
2. Bolt rack and pinion opener assembly (2) to sleeve connector using three bolt holes closest to bin wall.
3. Attach center sump connector (3) to opener using a 3/8 x 1" quick-release pin (7).
4. Attach rubber cap (8) to handle (1) and attach handle to opener.
5. Make sure sump gates are completely closed and then attach connectors to one another using a 3/8" x 1" quick-release pin (7).
6. Tighten setscrews in shaft collars.

Open sump gates by rotating handle clockwise. Sump gates should open and close fully.

IMPORTANT: Always open and unload from center sump first. Never open intermediate sumps until grain stops flowing from center sump.

OPERATING INSTRUCTIONS

IMPORTANT: This sweep is designed for single-stage sweeping only. Verify that bin is designed for single-stage sweeping.

Standard Sukup grain bins are designed with anchors that allow sweeping of entire diameter of bin in one stage. However, older Sukup bins 72' dia. and larger that do not have two anchors per stiffener should be swept in multiple stages beginning with inner section of floor, and then outer section after sweep extension is added. Additional anchor brackets can be purchased from Sukup Manufacturing Co. and retrofitted to enable single-stage sweeping.

For single-stage sweeping of Sukup bins 54' to 105' in diameter, bin must have 1" Grade 5 anchor bolts (17" deep for "Inverted T" foundation, or deep into stemwall ring rebar zone for "T-Cap"), with a minimum of 7-1/2" from anchor to outside edge of stemwall. Check bin anchor specifications prior to using sweep.

Bins by other manufacturers that are 60' dia. or less may be swept in one stage provided anchors have been inspected and found suitable for single-stage sweeping. (Contact bin manufacturer for further information). For larger bins by others, sweep in multiple stages: Use only inner section of sweep on first pass, making one revolution around bin, then connect outer section and sweep remainder of bin.



DANGER: KEEP AWAY when auger is running. Entanglement with rotating auger will cause death or serious injury.

NOTICE: If bin is equipped with a Cluster Buster, ensure neither rod nor cable is in torsion bar. If bin is equipped with a sidedraw, do not use at same time sumps are being used to unload grain.

1. Start horizontal (and vertical if applicable) unload auger(s). Open center sump. Unload grain from center sump until gravity flow stops.
2. Open intermediate sumps, allowing additional gravity flow into unloading auger. If bin has an independent intermediate sump, open it by pulling rod shown in Fig. 32.

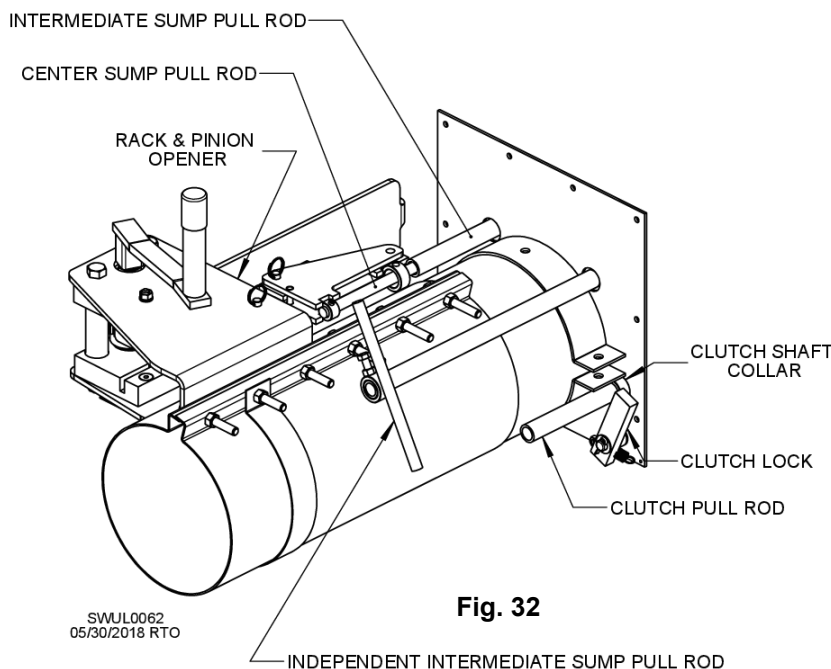

3. When grain flow stops, shut off power to system. Engage sweep auger by pulling clutch rod.
NOTICE: Power must be shut off before engaging sweep auger to prevent damage to clutch assembly.

Operation

4. Turn on power. Center sump slide gate must remain **FULLY** open and sweep stop must be deployed while sweep auger is operating. Remove remaining grain, making sure to reposition stop before each revolution. **NOTICE:** Leave bottom panel of inner bin door closed when running sweep to avoid possible damage to sweep wheel and/or door.



DANGER: When bin is nearly empty, sweep auger will travel at an increasingly fast speed. Keep away from auger to avoid entanglement, which will result in death or serious injury.

5. Close sumps and place sweep just behind intermediate sumps.

NOTE: If a slower flow of grain is desired, (e.g., grinding) a larger driven pulley (12" comes standard) should be used on unload auger. (14" pulley available from Sukup Manufacturing Co.)

NOTE: If grain starts to pile up in center of bin when power sweep is engaged and center sump is fully open, sweep may need to be slowed down. To do so, sprocket on lower gearbox should be changed. On 8" unit, replace standard 15-tooth sprocket with a 12-tooth sprocket (Comp. # J1660). On 10" unit, replace standard 20-tooth sprocket with an 18-tooth sprocket (Comp. # J1690). See Service Bulletin L1838. **NOTE:** When changing sprockets, chain links may need to be removed.

TROUBLESHOOTING GUIDE

PROBLEM	REASON	SOLUTION
1. Sweep is not moving around bin.	Scraper too close to floor.	Raise scrapers up.
	Bent edge is down by floor.	Turn scraper around so sharp edge is at bottom.
	Obstacles may be hindering forward movement.	Check for any obstacles that scraper could be catching on. May need to raise scraper.
	Grain is keeping sweep from moving into pile.	Remove front carrier wheels (on sweeps larger than 39') to allow easier forward movement.
2. Sweep is not filling unload auger to capacity. (10" Sweepway)	Sweep is not going fast enough.	Increase sweep auger capacity by increasing size of lower gearbox 20-tooth sprocket to a 24-tooth sprocket, (Part #J16957). May have to lengthen chain with 24-tooth sprocket. It will increase speed by 20%.
3. Drive chain breaking. (8" & 10" Sweepway)	Grain piling in center of bin.	Make sure center sump gate is fully open.
		Sweep can be slowed down by decreasing size of sprocket on lower gearbox from a 15-tooth to a 12-tooth (Part #J1660) for 8"; or from a 20-tooth to an 18-tooth (Part #J1690) for 10". See Service Bulletin L1838. May have to shorten chain if using smaller sprocket. It will decrease speed by 20% for 8"; 10% for 10".
4. When using an incline auger, capacity is cut dramatically.	Moving very small grains or hard flowing grains. Example: rice, wheat, soybeans, etc.	Weld a piece of flighting, (6-8" incline use Part #E5638, 8-10" incline use Part #E5639) onto end of unload auger to get flighting extended fully to U-joint. This will decrease amount of gap grain has to flow through, increasing capacity.
5. Connector link coming off.	Chain is too high & rubbing on top of sump.	On units built prior to 2003, chain can be lowered by replacing old sprocket on top gearbox with a new sprocket (E5837). Old spacer (E60041) on lower gearbox must also be replaced with a new spacer (E60042).
	Connector link is on backwards.	Connector link clip needs to have closed end leading chain around.

LUBRICATION

Use 140-weight gear oil in gearboxes. Gearboxes should be checked every time bin is empty. Check plugs are on back of gearboxes. Gearboxes should be about half full. Add grease to top bearing through zerk on top of each sump gearbox. On single-motor vertical drive, add oil through fill plug. Grease roller chain in sump every time bin is empty. Factory oil used in gearboxes is Mobil Gear 636, 140-weight.

PARTS ASSEMBLIES

SWEEPWAY ASSEMBLY

6", 8" & 10"

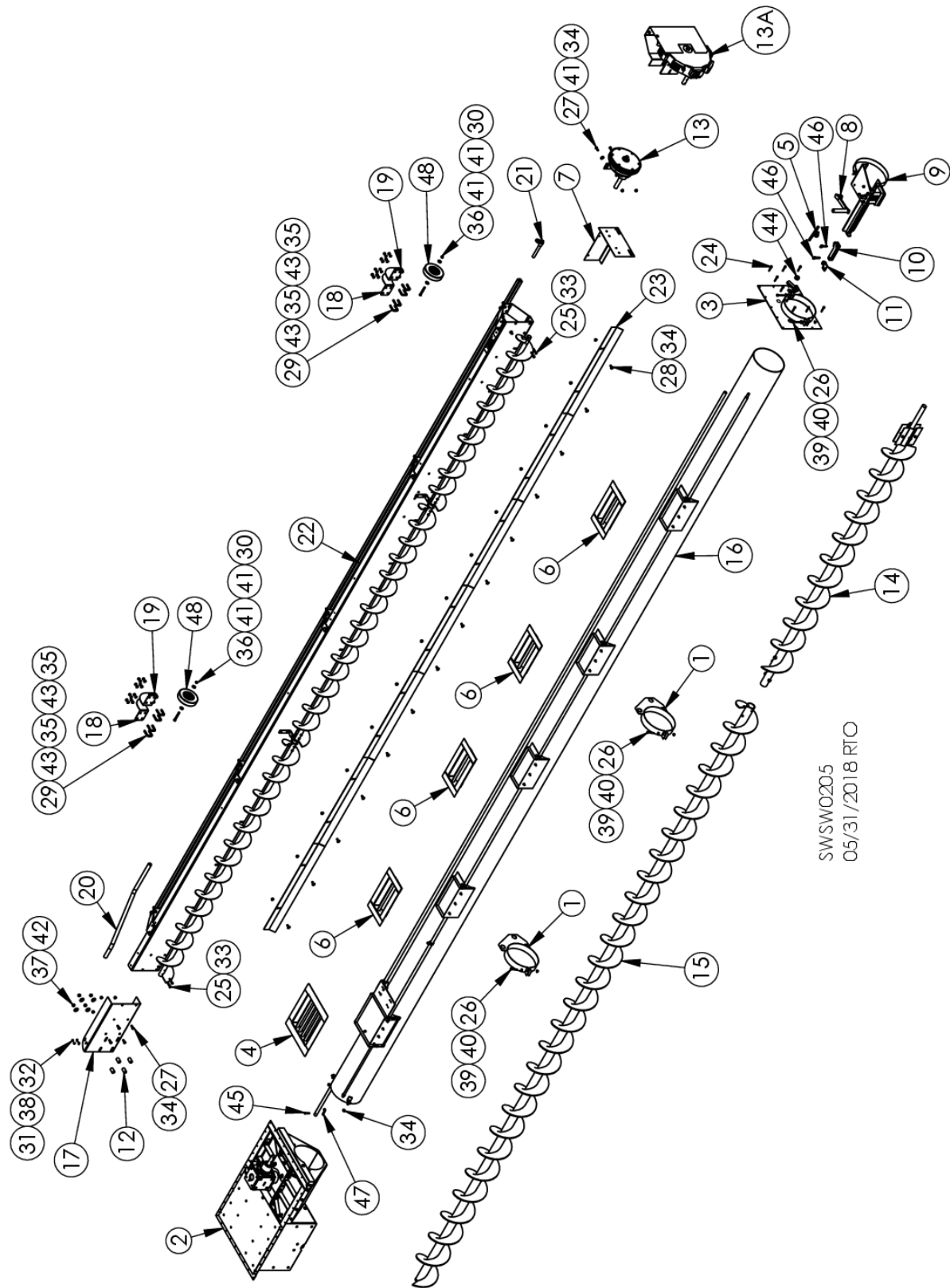

SWSW0205
05/31/2018 RTO

SWEEPWAY ASSEMBLY PARTS LIST

*

REF. #	DESCRIPTION	QTY.	6" COMP. #	8" COMP. #	10" COMP. #
1	Clutch rod support clamp	*	E5314	E5364	E53162
2	Sump & gearbox, complete	1	E5332	E5387	E5334
3	Bin collar	1	E5405	E5406	E5362
4	Independent intermediate sump top	1	---	E53989	E53964
5	Sump pull rod handle	1	---	E5404	E5404
6	Top half of intermediate sump	*	E5410	E5410	E5411
7	Sweep stop	1	E5514	E5514	E5514
8	Opener handle	1	E5967	E5967	E5967
9	Sump opener assy.	1	E5432	E5919	E5969
10	Center sump connector	1	E5889	E5914	E5997
11	Intermediate sump connector	1	E5888	E5998	E5998
12	Spacer, 1/2" ID	4	E6014	E6014	E6013
13	Reduction drive wheel, 4:1	1	E6094	E6092	E6093
13A	Reduction drive wheel, 16:1	1	E7336	E7338	E7340
14	Unload auger	*	*	*	*
15	Unload auger, 20', inside section	*	---	E6472	E6497
16	Unload tube	1	*	*	*
17	Backboard extension bracket	1	E6976	E6977	E6979
18	Rear carrier wheel bracket, right	*	E7740	E7740	E7740
19	Rear carrier wheel bracket, left	*	E7741	E7741	E7741
20	Cluster Buster tube	1	E7968	E7968	E7969
21	Cluster Buster plug rod assy.	1	E7985	E7985	E7985
22	Auger/backboard	1	*	*	*
23	Scraper, 36"	*	E8430	E8430	E8430
24	Screw, 1/4 – 14 x 1-3/4", self-drilling	*	J04981	J04981	J04981
25	Screw, 5/16 – 18 x 1-3/4"	*	J0570	J0570	J0570
26	Screw, 5/16 – 18 x 2"	*	J0584	J0584	J0584
27	Screw, 3/8 – 16 x 1"	*	J0606	J0606	J0606
28	Carriage bolt, 3/8 x 1"	*	J06064	J06064	J06064
29	Square U-bolt, 3/8" - 16	*	J0644	J0644	J0644
30	Screw, 3/8 - 16 x 3"	*	J0661	J0661	J0661
31	U-bolt, 1/4 – 20 x 1-1/8" ID, 2" deep	*	J08107	J08107	J08107
32	Lock nut, 1/4 – 20	*	J0992	J0992	J0992
33	Lock nut, 5/16" – 18	*	J1010	J1010	J1010
34	Flange lock nut, 3/8" - 16	*	J1017	J1017	J1017
35	Hex nut, 3/8" - 16	*	J1020	J1020	J1020
36	Lock nut, 3/8" – 16	*	J1025	J1025	J1025
37	Lock nut, 7/16" - 14	*	J1034	J1034	J1034
38	Flat washer, 1/4"	*	J1105	J1105	J1105
39	Whiz nut, 5/16" - 18	*	J1110	J1110	J1110
40	Flat washer, 5/16", PLT	*	J1111	J1111	J1111
41	Flat washer, 3/8", PLT	*	J1117	J1117	J1117
42	Flat washer, 7/16"	*	J1120	J1120	J1120
43	Split lock washer, 3/8"	*	J1205	J1205	J1205
44	Shaft collar, 7/8"	1	J1330	J1330	J1330
45	Picker pin, 3/8 x 1-1/2"	1	J1541	J1541	J1541
46	Quick-release pin, 3/8 x 1"	2	J1554	J1554	J1554
47	Hairpin clip, .09 x 2	1	J5410	J5410	J5410
48	Rubber wheel, 6", 3/8" ID, w/ bushing	*	J7271	J7271	J7271

*Varies with bin size

TUBE ASSEMBLY & PARTS LIST

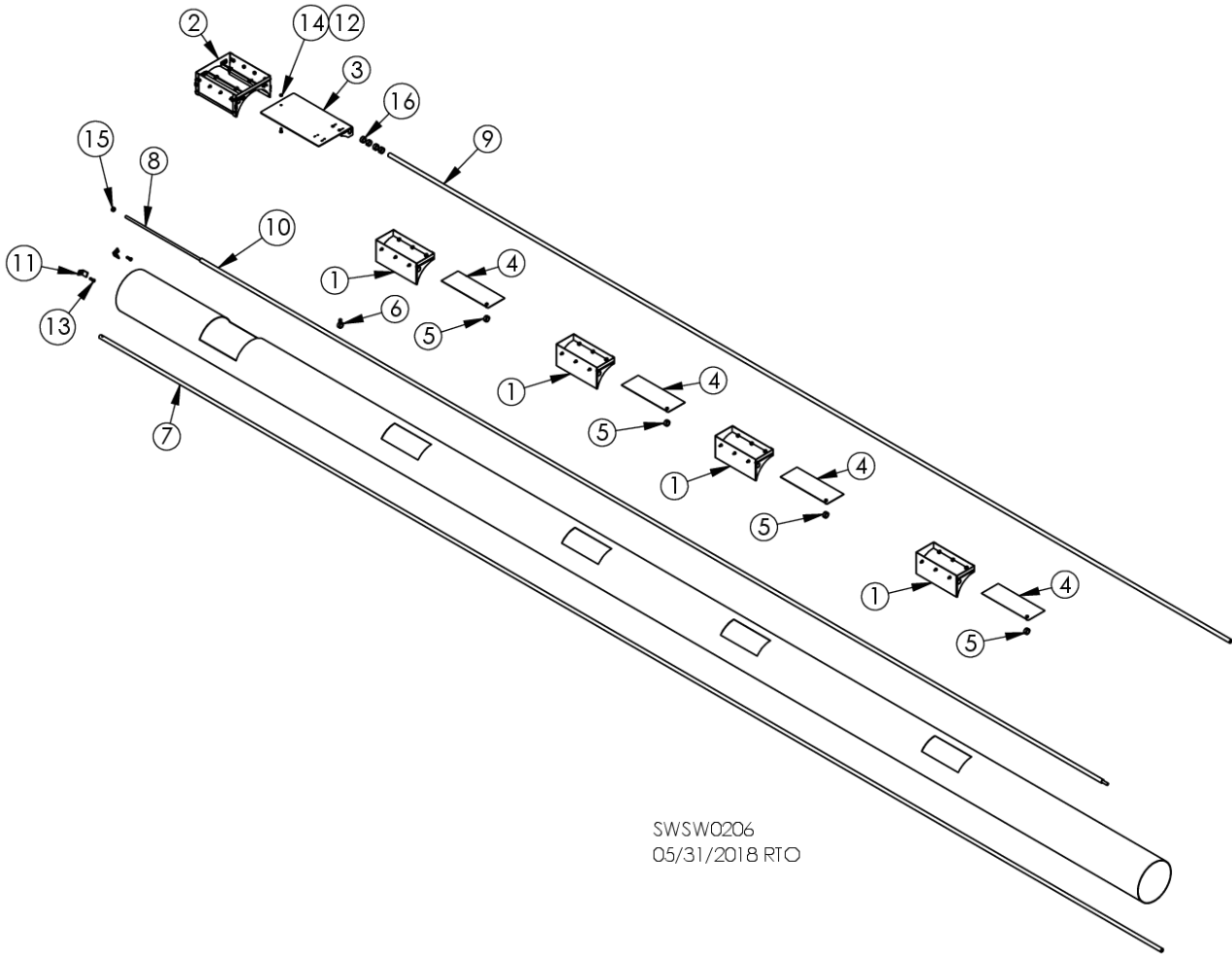

SWSW0206
05/31/2018 RTO

REF. #	DESCRIPTION	QTY.	6" COMP. #	8" COMP. #	10" COMP. #
1	Intermediate sump, w/ rollers	*	E5390	E5398	E5395
2	Independent int. sump, 10", 2018	1	---	E53981	E53951
3	Independent int. sump slide gate assy., 10"	1	---	E53987	E53963
4	Intermediate sump slide gate assy., 6" & 8"	*	E5409	E5409	E5409
5	Shaft collar, 7/8", no set screw	*	E5448	E5448	E5448
6	Shaft collar, 7/8", w/ bolt	1	E5449	E5449	E5449
7	Clutch rod	1	*	*	*
8	Center sump pull rod	1	*	*	*
9	Independent intermediate sump pull rod	1	---	*	*
10	Intermediate sump pull rod	1	*	*	*
11	Tab, 1-1/2" x 1"	2	F4415-01	F4415-01	F4415-01
12	Screw, 5/16 – 18 x 3/4"	*	J0520	J0520	J0520
13	Screw, 3/8 – 16 x 1"	*	J0606	J0606	J0606
14	Lock nut, 5/16" – 18	*	J1010	J1010	J1010
15	Hex nut, 1/2" – 13	*	J1040	J1040	J1040
16	Shaft collar, 7/8"	*	J1330	J1330	J1330

*Varies with bin size

BACKBOARD ASSEMBLY & PARTS LIST

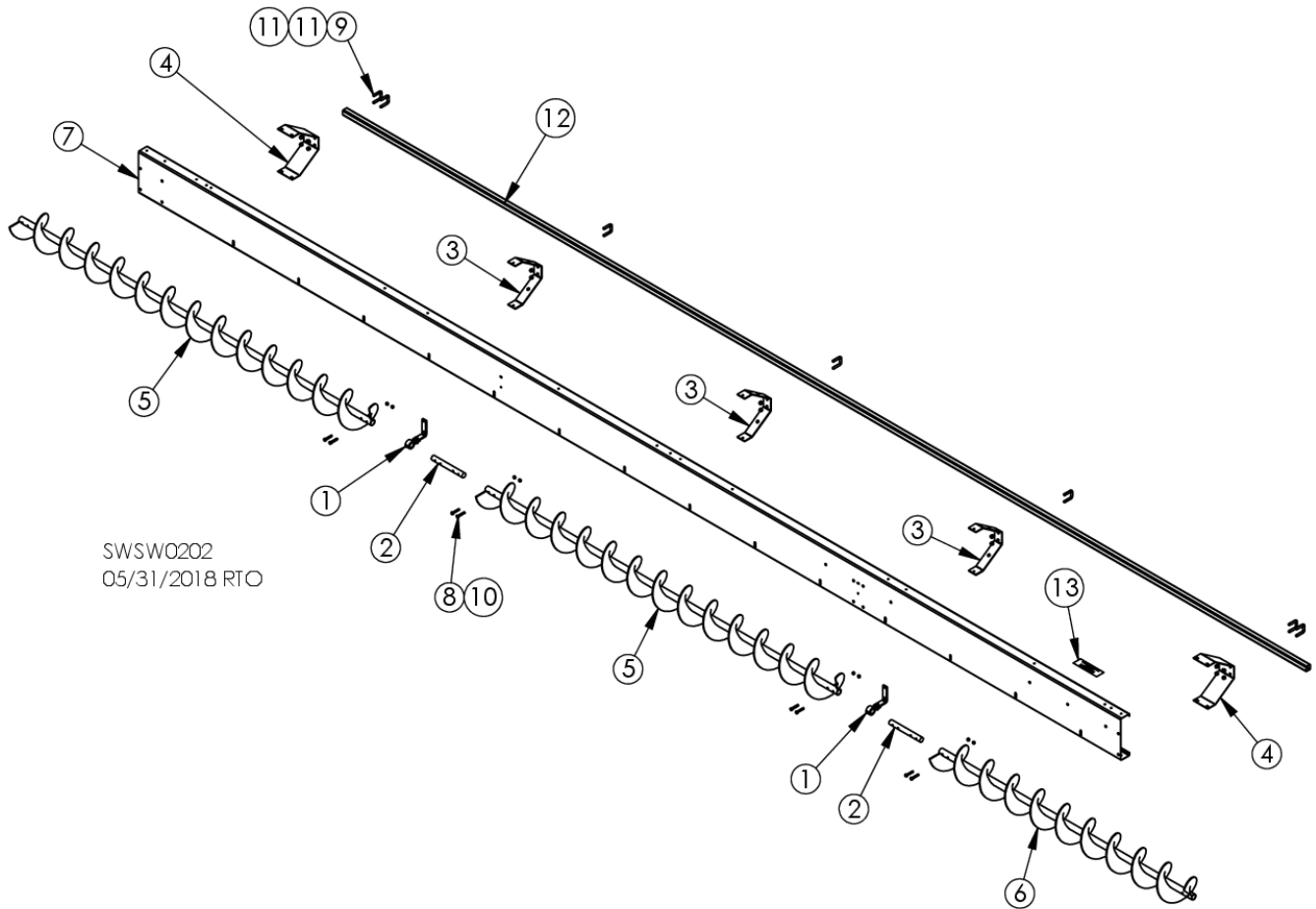

SWSW0202
05/31/2018 RTO

REF. #	DESCRIPTION	QTY.	6" COMP. #	8" COMP. #	10" COMP. #
1	Auger support bushing assy.	*	E6089	E6090	E6091
2	Auger connector shaft, 1" OD, 8-1/2" long	*	E6704-03	E6704-03	E6704-03
3	Torsion bar bracket	*	E6791	E6791	E6788
4	Torsion bar bracket, split	*	E6792	E6792	E6789
5	Auger	*	*	*	*
6	Auger extension	*	*	*	*
7	Backboard	1	*	*	*
8	Screw, 5/16 – 18 x 1-3/4"	*	J0570	J0570	J0570
9	Square U-bolt, 3/8" - 16	*	J0644	J0644	J0644
10	Lock nut, 5/16" – 18	*	J1010	J1010	J1010
11	Lock nut, 3/8" – 16	*	J1024	J1024	J1024
12	Square tubing	*	*	*	*
13	Decal, Danger, Auger Running	1	L03061	L03061	L03061

*Varies with bin size

HORIZONTAL POWERHEAD MOTOR DRIVE

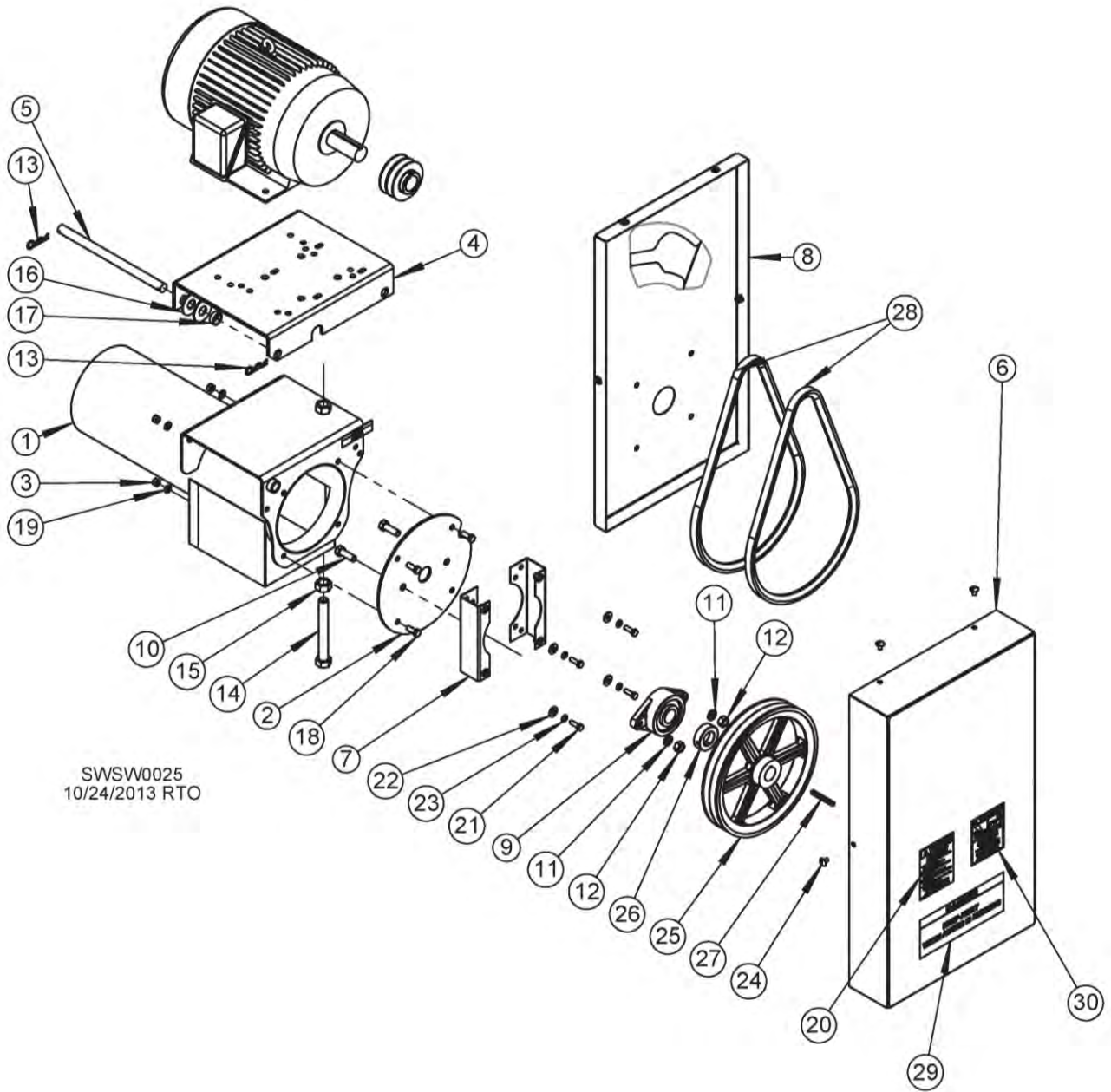

HORIZONTAL POWERHEAD MOTOR DRIVE PARTS LIST

REF.#	DESCRIPTION	QTY.	6" COMP. #	8" COMP. #	10" COMP. #
	Powerhead w/ shield & bearing	1	E5600	E5601	E5602
	HPH w/ bearing, shield, lg. motor mount.	1	-----	E5599	E5611
1	STD powerhead housing	1	E5567	E5568	E5569
2	6" bearing plate	1	E5676	-----	-----
	8" bearing plate	1	-----	E5776	-----
	10" bearing plate	1	-----	-----	E5659
3	Nut, 3/8 – 16, PLT	8-12	J1020	J1020	J1020
4	Hinged motor mount, small	1	E5746	E5746	E5746
	Hinged motor mount, large	1	-----	E5765	E5765
5	Small pivot rod	1	E5744	E5744	E5744
	Large pivot rod	1	-----	E57441	E57441
6	Outer shield	1	E5973	E5973	E5973
7	Shield bracket	2	E9316	E9316	E5974
8	Inner shield	1	E5972	E5972	E5972
9	1" flange bearing w/ locking collar	2	J0003	-----	-----
	1-1/4" flange bearing w/ locking collar	2	-----	J0010	J0010
	Bearing spacer (Not shown)	1	E5791	E5792	E5792
10	Bearing bolt w/ tab	2	E5570	-----	-----
	Bolt, 1/2 - 13 x 1-1/2", PLT	2	-----	J0730	J0730
11	Split lock washer, 7/16", PLT	2	J1210	-----	-----
	Split lock washer, 1/2", PLT	2	-----	J1215	J1215
12	Nut, 7/16 - 14, PLT	2	J1035	-----	-----
	Nut, 1/2" - 13, PLT	2	-----	J1040	J1040
13	Hairpin clip, .120 x 2.5	2	J5412	J5412	J5412
14	Tap bolt, 3/4 - 10 x 6", PLT	1	J0824	J0824	J0824
15	Nut, 3/4 - 10, PLT	1	J1051	J1051	J1051
16	Machine bushing, 3/4 x 1-1/4", 14ga	1-20	J1260	J1260	J1260
17	Long spacer, 3/8"	1	E5739	E5739	E5739
	Longer spacer, 2-7/16"	1	-----	E5740	E5740
18	Bolt, 3/8 – 16 x 1", PLT	4-6	J0606	J0606	J0606
19	Split lock washer, 3/8", PLT	4-6	J1205	J1205	J1205
20	Decal, Safe Operation	1	L0281	L0281	L0281
21	Bolt, 5/16 – 18 x 1", PLT	8	J0527	J0527	J0527
22	Flat washer, 5/16", PLT	4	J1111	J1111	J1111
23	Split lock washer, 5/16", PLT	8	J1200	J1200	J1200
24	Screw, 3/16 – 18 x 1/2", PLT, SL	4	J0519	J0519	J0519
25	Pulley, 12 x 1", single groove A-B	1	J0375	-----	-----
	Pulley, 12 x 1", DBL groove B	1	J0380	-----	-----
	Pulley, 12 x 1-1/4", DBL groove B	1	-----	J0385	-----
	Pulley, 12 x 1-1/4", triple groove B	1	-----	J0379*	J0379*
	Pulley, 12 x 1-1/4", single groove A-B	1	-----	J0388	-----
26	Locking collar, 1"	1	J0067	-----	-----
	Locking collar, 1-1/4"	1	-----	J0068	J0068
27	Key, 1/4" x 2-1/2"	1	E5720	E5720	E5720
28	Belt, BX48 BX50	1-2	J0220	J0220	J0224
	Belt, B52 "3 drive belt"	3	-----	-----	J0227
29	Decal, Do Not Enter Bin, Avoid Augers	1	L0258A	L0258A	L0258A
30	Decal, Keep Away From Moving Parts	1	L0284	L0284	L0284

*J0379 pulley requires J0410 bushing

BASIC VERTICAL AUGER

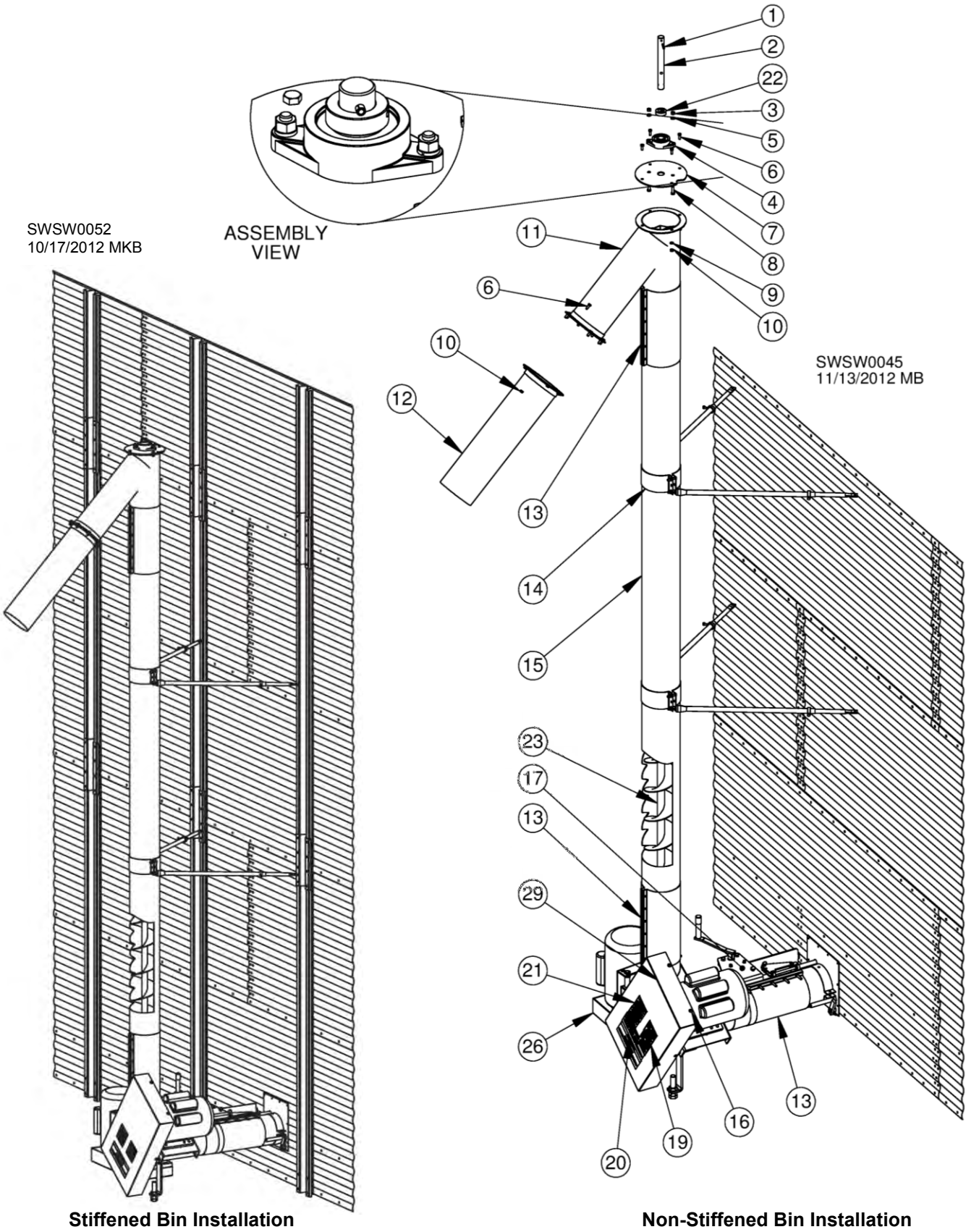

Parts Assemblies

BASIC VERTICAL AUGER PARTS LIST

REF. #	DESCRIPTION	QTY.	6" COMP. #	8" COMP. #	10" COMP. #
1	Rollpin, 5/16" x 1-3/4"	1	J1495	J1495	J1495
2	Top shaft	1	E58091	E97711	E58243
3	Hex nut, 7/16" -14, PLT	2	J1035	-----	-----
	Hex nut, 1/2" - 13, PLT	2	-----	J1040	J1040
4	1" flange bearing w/ lock collar	1	J0003	-----	-----
	1-1/4" flange bearing, w/ lock collar	1	-----	J0010	J0010
5	Split lock washer, 7/16", PLT	2	J1210	J1210	-----
	Split lock washer, 1/2", PLT	2	-----	-----	J1215
6	Bolt, 3/8 - 16 x 1", GR 5, PLT	12	J0606	J0606	-----
	Bolt, 7/16" - 14 x 1", GR5, PLT	12	-----	-----	J0695
7	Bearing end plate	1	E5676	E5776	E5659
8	Bolt, 7/16 - 14 x 1.25" GR5, PLT	2	J0700	-----	-----
	Bolt, 1/2 - 13 x 1.5", GR5, PLT	2	-----	J0730	J0730
9	Split lock washer, 3/8", PLT	2	J1205	J1205	-----
	Split lock washer, 7/16", PLT	2	-----	-----	J1210
10	Hex nut, 3/8" - 16, PLT	12	J1020	J1020	-----
	Hex nut, 7/16" - 14, PLT	12	-----	-----	J1035
11	Top outlet spout	1	E5812	E5813	E5785
12	2-1/2' truck spout	1	E5814	E5815	E5787
13	Connector sleeve	3	E5423	E5424	E5425
14	30" support bracket (bipod)	2	E5800	E5801	E5786
15	12' galvanized auger tube	1	E5842	E5843	E57842
16	Screw, 5/16 - 18 x 1/2", PLT, SL	8	J0519	J0519	J0519
17	Rack & pinion opener	1	-----	E5919	E5969
18	Hex nut, 5/16" - 18, PLT (Not shown)	2	J1002	J1002	J1002
19	Decal, Keep Away from Moving Parts	1	L0284	L0284	L0284
20	Decal, Do Not Enter Bin, Keep clear of augers	1	L0258A	L0258A	L0258A
21	Decal, Safe Operation	1	L0281	L0281	L0281
22	Locking collar, 1"	1	J0067	-----	-----
	Locking collar, 1-1/4"	1	-----	J0068	J0068
23	16' vertical auger w/ flinger & shafts (See page 80 for flighting, shafts & tubes)	1	E5846	E5847	E57833
24	Bottom shaft, w/ keyway (Not shown)	1	E58081	E9751	E58252
25	Decal, Shield Missing (Not shown)	1	L0271	L0271	L0271
26	Outer vertical shield	1	E5977	E5977	E5977
27	Inner vertical shield (Not shown)	1	E5976	E5976	E5976
28	Vertical shield bracket (Not shown)	2	E5978	E5978	E5978
29	Outer horizontal shield	1	E5973	E5973	E5973
30	Inner horizontal shield (Not shown)	1	E5972	E5972	E5972
31	Horizontal shield bracket (Not shown)	2	E9316	E9316	E5974
32	Screw, 5/16 - 18 x 1", PLT, GR5 (Not shown)	6	J0527	J0527	J0527
33	Split lock washer, 5/16", PLT (Not shown)	6	J1200	J1200	J1200
34	Flat washer, 5/16", PLT, (Not shown)	6	J1111	J1111	J1111

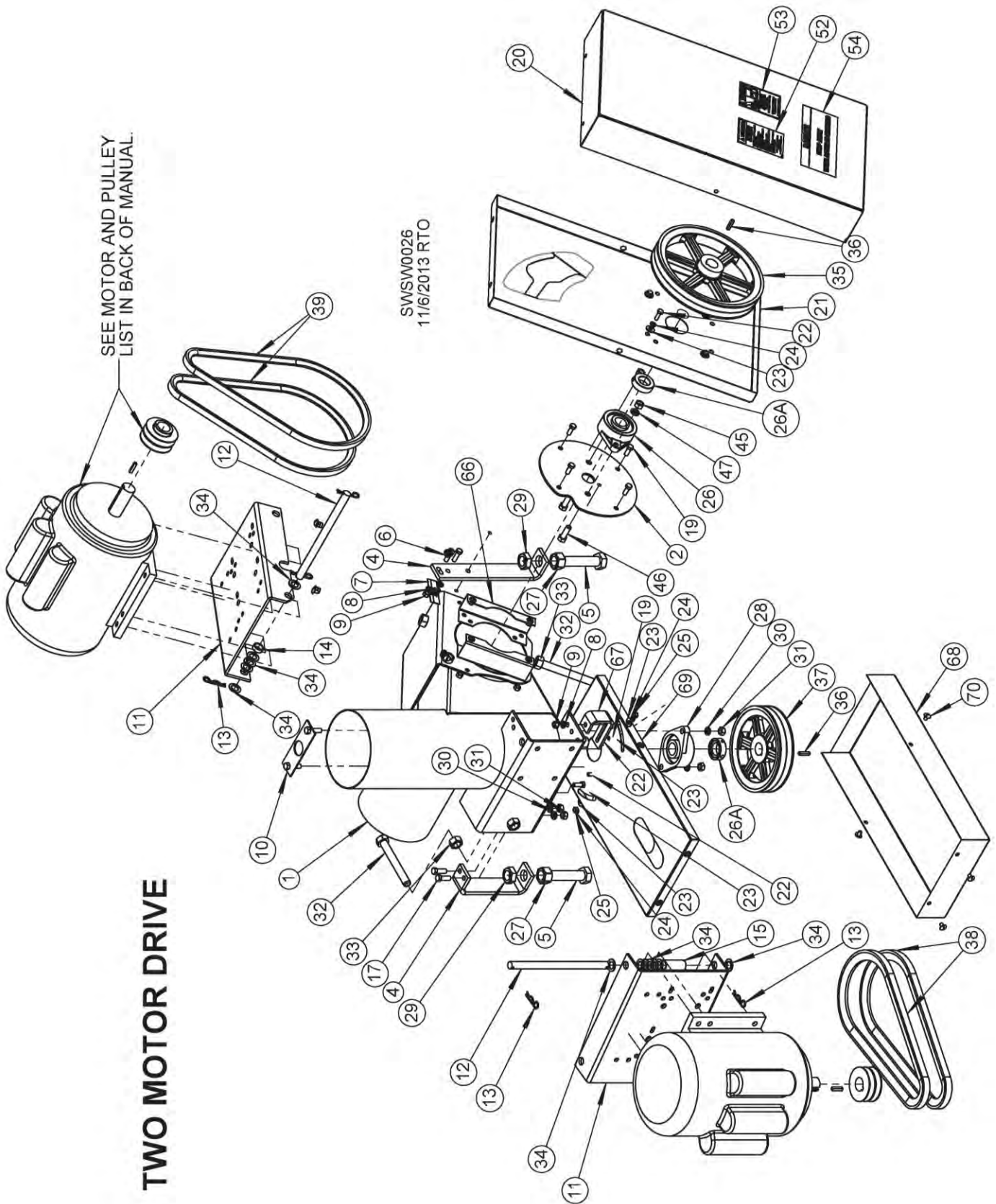

Table applies to two-motor drive and one-motor drive units

VERTICAL BOOT OPTIONS

REF. #	DESCRIPTION	6"	8"	10"
	Vertical boot drive, 2 motor	E5816	E5817	E5782
	Vertical boot drive, 1 motor	E5820	E5821	-----
1	Vertical boot housing	E5767	E5768	E5769
2	Bearing plate	E5676	E5776	E5659
3	Sliding door (Not shown)	E5771	E5771	E5771
	Bolt-on leg bracket (front)	E5869	E5869	E5869
4	Bolt-on leg bracket (front) +6, Euro	E5879	E5879	E5879
	Bolt-on leg bracket (back)	E5868	E5868	E5868
	Bolt-on leg bracket (back) +6, Euro	E5878	E5878	E5878
5	Adjustable leveling foot	F4564	F4564	F4564
6	Bolt, 3/8-16 x 1-1/4", PLT, GR5	J0616	J0616	J0616
7	Flat washer, 3/8", PLT	J1117	J1117	J1117
8	Split lock washer, 3/8", PLT	J1205	J1205	J1205
9	Nut, 3/8" - 16, PLT	J1020	J1020	J1020
10	Bearing holder	E5840	E5731	E5731
11	Hinged motor mount plate, small	E5746	E5746	E5746
	Hinged motor mount, 3-belt drive	-----	-----	E5765
12	Pivot rod, small	E5744	E5744	E5744
	Pivot rod, 3-belt drive	-----	E57441	E57441
13	Hairpin clip	J5412	J5412	J5412
14	Spacer, small, 3/8" long	E5739	E5739	E5739
15	Spacer, large, 2-5/8" long	E5740	E5740	E5740
16	Shield bracket	E5870	E5870	E5870
17	Screw, 7/16 - 14 x 1-1/4", PLT	J0700	J0700	J0700
18	Vertical shield bracket (Not shown)	E5571	E5571	E5571
19	Bolt, 3/8 - 16 x 1", PLT, GR5	J0606	J0606	J0606
20	Outer shield, horizontal	E5973	E5973	E5973
21	Inner shield, horizontal	E5972	E5972	E5972
22	Bolt, 5/16 - 18 x 1", PLT	J0527	J0527	J0527
23	Flat washer, 5/16", PLT	J1111	J1111	J1111
24	Split lock washer, 5/16", PLT	J1200	J1200	J1200
25	Nut, 5/16" - 18, PLT	J1002	J1002	J1002
26	Flange bearing, 1", w/ lock collar	J0003	-----	-----
	Flange bearing, 1-1/4", w/ lock collar	-----	J0010	J0010
26A	Locking collar, 1"	J0067	-----	-----
	Locking collar, 1-1/4"	-----	J0068	J0068
27	Hex nut, 1" - 8, PLT	J1060	J1060	J1060
28	Flange bearing, 1", w/ LC for 2 bolt	J00031	-----	-----
	Flange bearing, 1-1/4", w/ LC for 2 bolt	-----	J00102	J00102
29	Jam nut, 1" - 8	J1063	J1063	J1063
30	Split lock washer, 7/16", PLT	J1210	J1210	J1210
31	Nut, 7/16" - 14 PLT	J1035	J1035	J1035
32	Bolt, 3/4 - 10 x 6", PLT, GR5	J0824	J0824	J0824
33	Nut, 3/4 - 10, PLT, GR5	J1051	J1051	J1050
34	Flat washer, 3/4", PLT	J1130	J1130	J1130
	Pulley, 12" OD x 1", B, single groove	J0375	-----	-----
35	Pulley, 12" OD x 1-1/4", B, double grv.	-----	J0385	J0385
	Pulley, 12" OD x 1-1/4", B, 3-belt drive	-----	J03865*	J03865*

REF. #	DESCRIPTION	6"	8"	10"
36	Key, 1/4" x 1-1/4"	G7499	G7499	G7499
	Key, 1/4" x 2-3/4", 3-belt drive	-----	-----	E5721
37	Pulley, 9" OD x 1", double groove	J0365	-----	-----
	Pulley, 9" OD x 1-1/4", double groove	-----	J0366	J0366
38	Belt, BX42	J0200	J0200	J0200
	Belt, BX46	-----	-----	J0215
39	Belt, BX48 - BX50	J0220	J0220	J0224
	Belt, BX52 - BX54, 3-belt drive	-----	J0227	J0222
40	Nut, 5/16" - 18	J1009	J1009	J1009
41	Carriage bolt, 5/16 - 18 x 1"	J0535	J0535	J0535
42	Split lock washer, 1/2", PLT	J1215	J1215	J1215
43	Machine bushing, 1/2", 18ga.	J1250	J1250	J1250
44	Nut, 1/2" - 13, PLT	J1040	J1040	J1040
45	Nut, 1/2" - 13, PLT	J1040	J1040	J1040
	Nut, 7/16" - 14, PLT	J1035	-----	-----
46	Bolt, 1/2 - 13 x 1-1/2", PLT, GR5	-----	J0730	J0730
	Bolt, 7/16 - 14 x 1-1/2", PLT, GR5	-----	J0710	-----
47	Split lock washer, 1/2", PLT	-----	J1215	J1215
	Split lock washer, 7/16", PLT	-----	J1210	-----
48	Bolt, 1/2 - 13 x 2", PLT, GR5	J0737	J0737	J0737
49	Flat washer, 1/2", PLT	J1125	J1125	J1125
50	Bolt, 7/16 - 14 x 1" PLT	J0695	J0695	J0695
51	Shield bracket, 11-3/4"	E9786	E9786	E9786
52	Decal, Safe Operation	L0281	L0281	L0281
53	Decal, Keep Away From Moving Parts	L0284	L0284	L0284
54	Decal, Do Not Enter Bin, Avoid Augers	L0258A	L0258A	L0258A
55	Key, 1-1/4 x 2-3/4"	E5721	E5721	E5721
	Sprocket, 50B15, 1" bore	J1665	J1665	J1665
56	Sprocket, 60B15, 1" bore	J1694	J1694	J1694
	Sprocket, 60B15, 1-1/4" bore	-----	J16941	-----
57	Gearbox	E5822	E5822	-----
58	Gearbox shield	E5576	E5576	-----
	Chain, #50, 71 links	-----	E58311	-----
	Chain, #50, 65 links	E5832	-----	-----
59	Chain, #60, 55 links	G90460	-----	-----
	Chain, #60, 61 links	-----	E58310	-----
60	Chain, #50, 43 links	F4492	F4492	-----
61	Idler bracket - (Single motor)	E5779	E5779	-----
62	Sprocket, 50B15, 1-1/4" bore	-----	J1664	-----
	Sprocket, 50B15, 1" bore	J1665	-----	-----
63	Large shield, horizontal	E5826	E5826	-----
64	Sprocket idler, 50-13	J1685	J1685	-----
	Sprocket idler, 60-13	J1687	J1687	-----
65	Idler bracket	E5742	E5742	-----
66	Shield bracket, horizontal drive	E9316	E9316	E5974
67	Shield bracket, vertical drive	E5978	E5978	E5978
68	Outer shield, vertical	E5977	E5977	E5977
69	Inner shield, vertical	E5976	E5976	E5976
70	Screw, 5/16 - 18 x 1/2", PLT	J0519	J0519	J0519

10/12/2016

*Use J0410 bushing with J03865 pulley

SEE MOTOR AND PULLEY LIST IN BACK OF MANUAL.

SWSW0027
01/08/2008THW

ONE MOTOR DRIVE

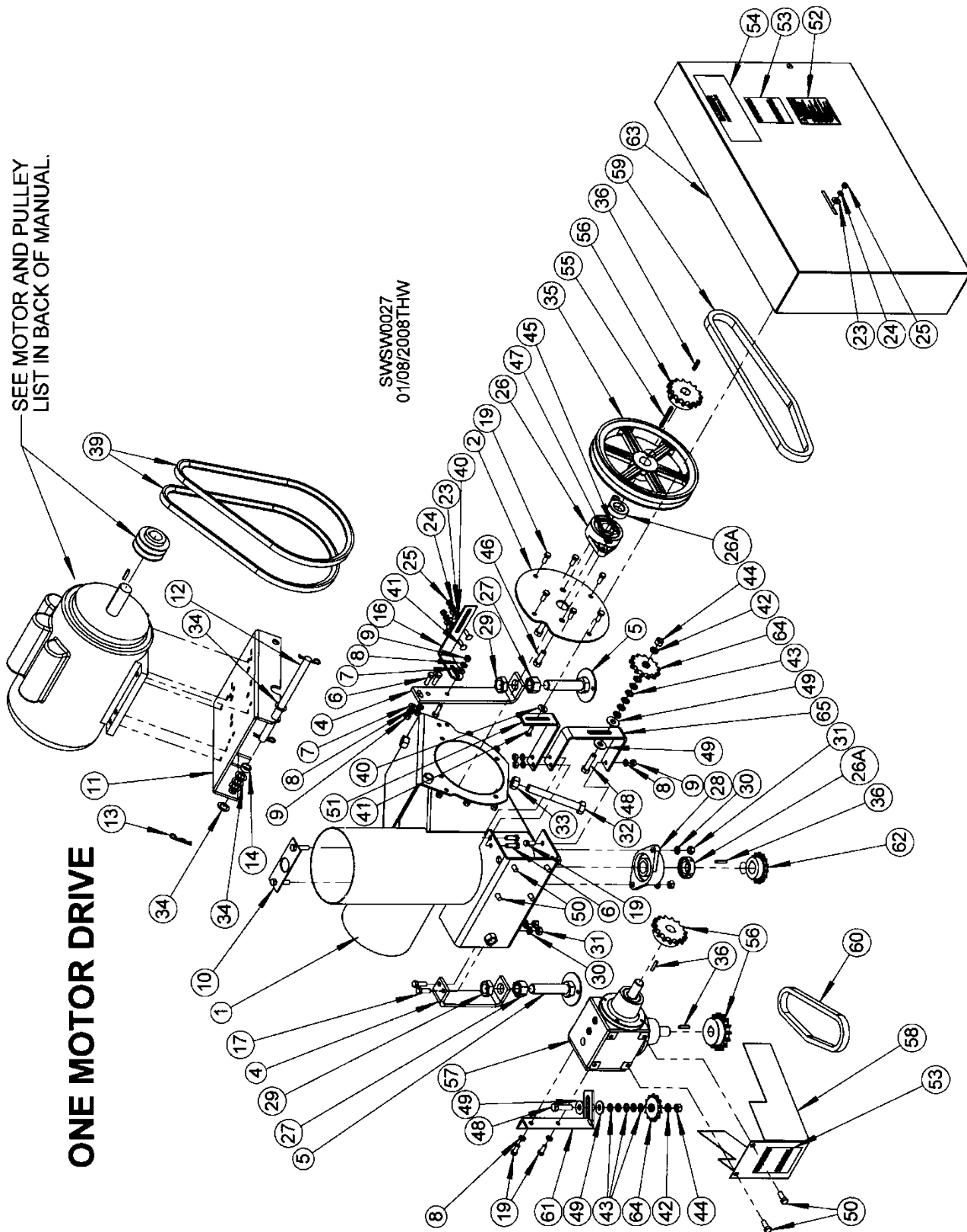

CONNECTOR SLEEVE & UNLOAD AUGER ASSEMBLY, PARTS LIST

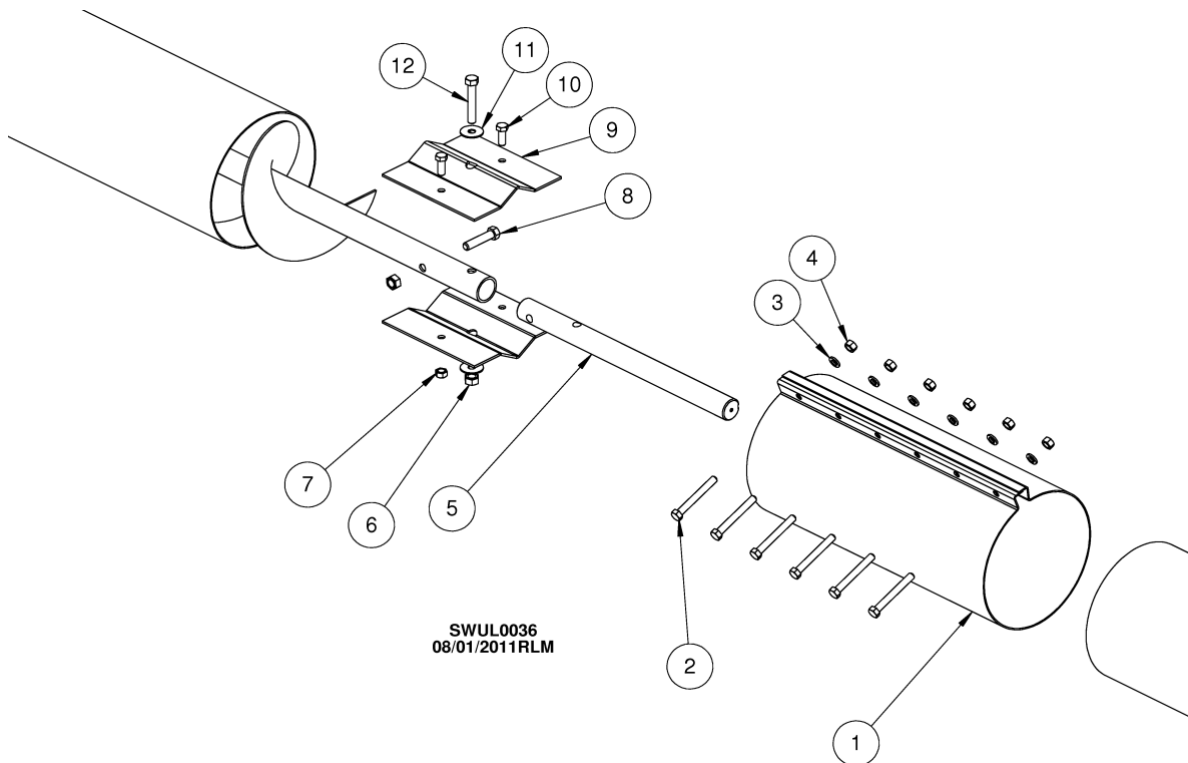

SWUL0036
08/01/2011RLM

REF. #	DESCRIPTION	QTY.	6" COMP. #	8" COMP. #	10" COMP. #
1	Connector sleeve, 6 x 18"	1	E5423	--	--
	Connector sleeve, 8 x 18"	1	--	E5424	--
	Connector sleeve, 10 x 18"	1	--	--	E5425
2	Screw, 3/8 - 16 x 3", PLT	6	J0660	J0660	J0660
3	Lock washer, 3/8", PLT	6	J1205	J1205	J1205
4	Hex nut, 3/8 - 16, PLT	6	J1020	J1020	J1020
5	Shaft, 1" x 15-1/4", w/ key	1	E90061	--	--
	Shaft, 1-1/4 x 15-3/4", w/ key	1	--	E54151	--
	Shaft, 2 x 18", w/ key	1	--	--	E54142
6	Lock nut, 5/16" - 18, PLT	2	J1010	--	--
	Lock nut, 7/16" - 14, PLT	2	--	J1034	--
	Lock nut, 1/2" - 13, PLT	2	--	--	J1042
7	Lock nut, 3/8" - 16	2	J1025	J1025	J1025
8	Screw, 5/16 - 18 x 1-3/4", PLT	1	J0570	--	--
	Screw, 7/16 - 14 x 2", PLT	1	--	J0718	--
	Screw, 1/2 - 13 x 3", PLT	1	--	--	J0750
9	Flinger, 3 x 5-3/8, 6"	2	E5416	--	--
	Flinger, 5 x 6-1/2, 8"	2	--	E54161	--
	Flinger, 7 x 7-1/2, 10"	2	--	--	E5689
10	Screw, 3/8 - 16 x 1", PLT	2	J0606	--	--
	Screw, 3/8 - 16 x 1", PLT	2	--	J0606	--
	Screw, 3/8 - 16 x 1-3/4", PLT	2	--	--	J0645
11	Flat washer, 3/8", PLT	2	--	J1117	--
12	Screw, 5/16 - 18 x 2", PLT	1	J0585	--	--
	Screw, 7/16 - 14 x 2-1/2", PLT	1	--	J0720	--
	Screw, 1/2 - 13 x 3-1/2", PLT	1	--	--	J0754

Shaft (not shown) for connecting inner & outer auger sections: 6" – E5416 -; 8" – E54151 10" – F48412

TOP DRIVE ASSEMBLY

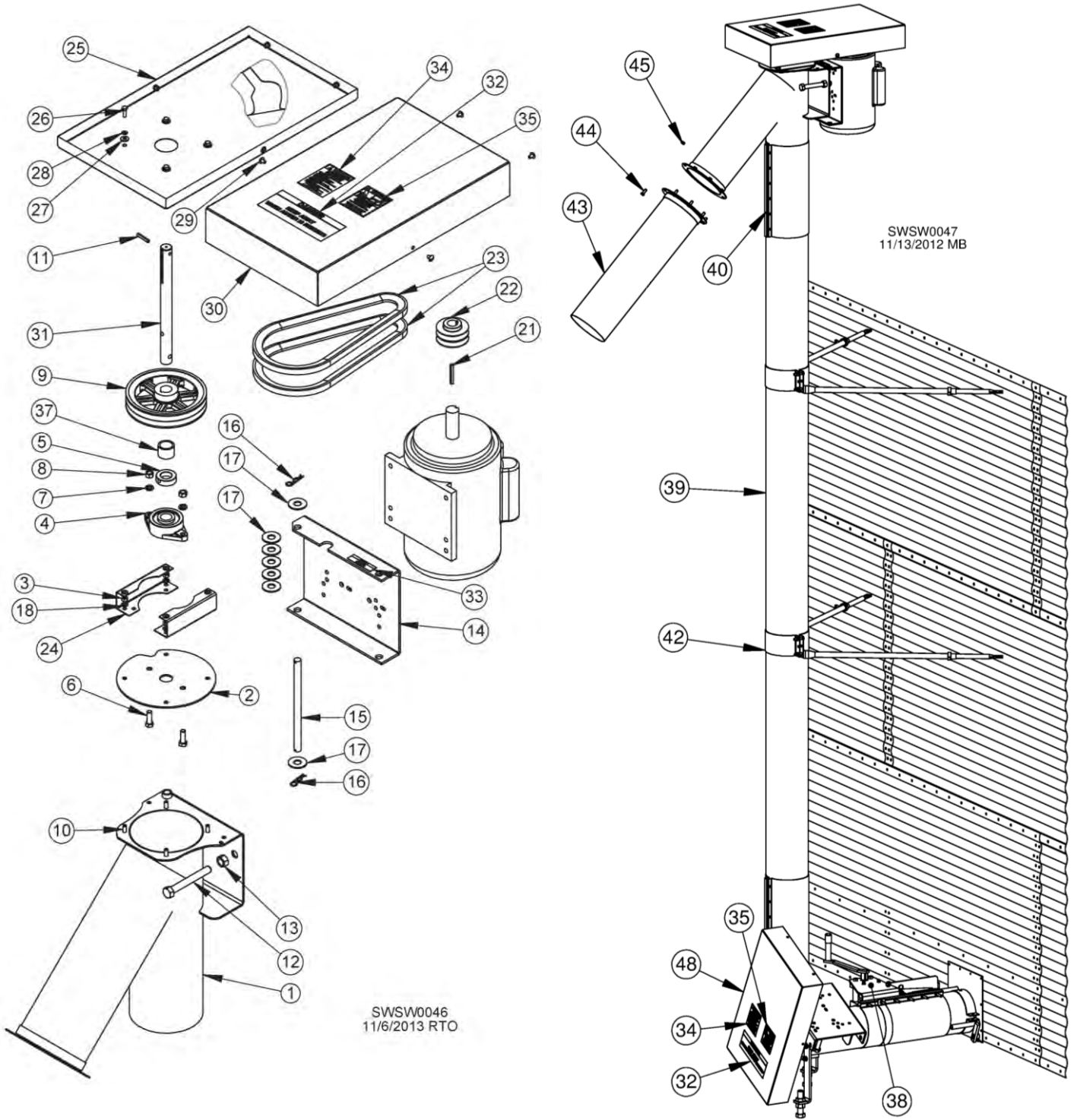

Parts Assemblies

TOP DRIVE ASSEMBLY PARTS LIST

REF. #	DESCRIPTION	QTY.	6" COMP. #	8" COMP. #	10" COMP. #
1	Top power housing spout	1	E5929	E5933	E57851
2	Bearing plate	1	E5676	E5776	E5659
3	Hex nut, 3/8" - 16, PLT	4	J1020	J1020	----
	Hex nut, 7/16" - 14, PLT	4	----	----	J1035
4	Flange bearing	2	J0003	J0010	J0010
5	Locking collar	3	J0067	J0068	J0068
6	Bolt, 7/16 - 14 x 1-1/4", GR5, PLT	2	J0700	----	----
	Bolt, 1/2 - 13 x 1-1/2", GR5, PLT	2	----	J0730	J0730
7	Split lock washer, 7/16", PLT	2	J1210	----	----
	Split lock washer, 1/2", PLT	2	----	J1215	J1215
8	Hex nut, 7/16" - 14, PLT	2	J1035	----	----
	Hex nut, 1/2" - 13, PLT	2	----	J1040	J1040
9	Pulley, 9" OD 2 groove	1	J0365	J0366	J0366
10	Bolt, 3/8 - 16 x 1", GR5, PLT	4	J0606	J0606	----
	Bolt, 7/16 - 14 x 1", GR5, PLT	4	----	----	J0695
11	Rollpin, 5/16 x 1-3/4", PLT	1	J1495	J1495	J1495
12	Bolt, 3/4 - 10 x 6", GR5, PLT	1	J0824	J0824	J0824
13	Hex nut, 3/4" - 10, PLT	1	J1051	J1051	J1051
14	Hinged motor mount, small	1	E5746	E5746	E5746
15	Pivot rod, small	1	E5744	E5744	E5744
16	Hairpin clip, .120 x 2.5	1	J5412	J5412	J5412
17	Flat washer, 3/4", PLT	2	J1130	J1130	J1130
18	Split lock washer, 3/8", PLT	4	J1205	J1205	----
	Split lock washer, 7/16", PLT	4	----	----	J1210
19	Split lock washer, 3/8", PLT	4	J1205	J1205	J1205
20	Hex nut, 3/8" - 16, GR5, PLT	5	J1020	J1020	J1020
21	Square key, 1/4 x 2-1/2"	1	E5720	E5720	E5721
22	Pulley, 3/2 P.D., 1-1/8 DBL, cast	1	J0317	J0317	J0317
23	Belt, BX42 (6 & 8") - BX46 (10")	2	J0200	J0200	J0215
24	Vertical shield bracket	2	E9316	E9316	E5974
25	Inner vertical shield	1	E5972	E5972	E5972
26	Bolt, 5/16 - 18 x 1", GR5, PLT	8	J0527	J0527	J0527
27	Flat washer, 5/16", PLT	8	J1111	J1111	J1111
28	Split lock washer, 5/16" PLT	4	J1200	J1200	J1200
29	Screw, 5/16 - 18 x 1/2", PLT, SL	8	J0519	J0519	J0519
30	Outer vertical shield	1	E5973	E5973	E5973
31	Top power shaft	1	E58092	E54153	E58244
32	Decal, Do Not Enter Bin, Keep Clear of Augers	1	L0258A	L0258A	L0258A
33	Decal, Danger, Replace Missing Shield	2	L0271	L0271	L0271
34	Decal, Safe Operation	2	L0281	L0281	L0281
35	Decal, Keep Away From Moving Parts	2	L0284	L0284	L0284
36	Decal, Sukup logo (Not shown)	1	L0317	L0317	L0317
37	Top drive spacer	1	E57415	E57415	E57415
38	Rack & pinion opener	1	----	E5919	E5969
39	Auger tube for 16' vertical	1	E5842	E5843	E57842
40	Connector sleeve	3	E5423	E5424	E5425
41	16' vert. auger w/ flinger & shafts (Not shown)	1	F4750	E58471	E57836
42	Support bracket, 30" (bipod)	1	E5800	E5801	E5786
43	Truck spout, 2-1/2'	1	E5814	E5815	E5787
44	Bolt, 3/8 - 16 x 1", GR5	6-8	J0606	J0606	J0606
45	Hex nut, 3/8" - 16	6-8	J1020	J1020	J1020
46	Horizontal shield bracket (Not shown)	2	E9316	E9316	E5974
47	Inner horizontal shield (Not shown)	1	E5972	E5972	E5972
48	Outer horizontal shield	1	E5973	E5973	E5973
49	Bottom shaft (Not shown)	1	F48101	G73291	F48342

25° INCLINE AUGER
6" to 8" & 8" to 10"

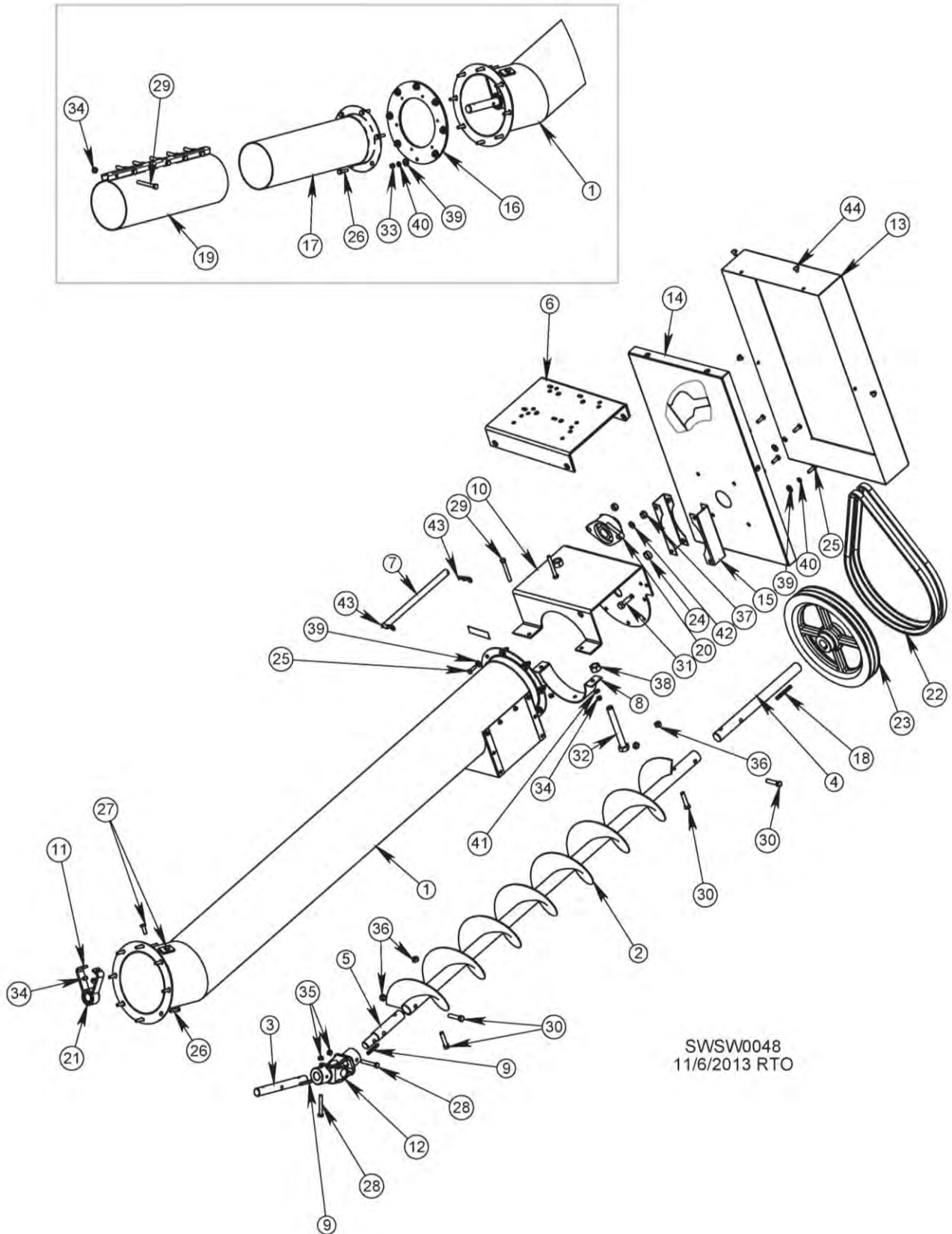

SWSW0048
11/6/2013 RTO

25° INCLINE AUGER PARTS LIST

REF. #	DESCRIPTION	QTY.	6-8" COMP. #	8-10" COMP. #
1	5' basic incline	1	E5950	E5940
2	Flighting & auger tube	1	E5622	E5623
3	Incline shaft	1	E56421	E5624
4	Shaft	1	E54151	E54142
5	Shaft, auger to knuckle	1	E56411	E56571
6	Hinged motor mount	1	E5746	E5746
7	Small pivot rod, PLT	1	E5744	E5744
8	10" clamp band, narrow	1	E97161	E5797
9	Key, 1/4"	2	F4499	E5915
10	Tube mount	1	E5958	E5948
11	Bushing support	1	E5956	E5947
12	Knuckle	1	E5980	E5980
13	Outer shield	1	E5973	E5973
14	Inner shield	1	E5972	E5972
15	Shield bracket	2	E9316	E9316
16	Adapter plate	1	E5953	E5943
17	Adapter sleeve mount	1	E5954	E5944
18	Key, 1/4" x 2-3/4"	1	E5721	E5721
19	Connector sleeve	1	E5423	E5424
20	Flange bearing w/ locking collar, 1-1/4"	1	J0010	J0010
21	Bushing, 1" x 1-1/4" x 1-1/4"	1	J00811	J00811
22	Belt, BX54	2	J0227	J0222
23	Pulley, 14 x 1-1/4", double "B" groove	1	J03951	J03951
24	Spacer, 3/8"	1	E5739	E5739
25	Bolt, 5/16 - 18 x 1", PLT, GR5	10	J0527	J0527
26	Bolt, 5/16 - 18 x 1-1/4", PLT, GR5	16	J0550	J0550
27	Bolt, 3/8 - 16 x 1", PLT, GR5	2	J0606	J0606
28	Screw, 3/8 - 16 x 2-1/2", PLT, GR5	2	J0655	J0655
29	Bolt, 3/8 - 16 x 3", PLT, GR5	6	J0660	J0660
30	Bolt, 7/16 - 14 x 2", PLT, GR5	4	J0718	---
	Bolt, 1/2 - 13 x 3", PLT, GR5	4	---	J0750
31	Bolt, 1/2 - 13 x 1-1/2", PLT, GR5	2	J0730	J0730
32	Bolt, 3/4 - 10 x 6", PLT, GR5	1	J0824	J0824
33	Hex nut, 5/16" - 18, PLT	20	J1002	J1002
34	Hex nut, 3/8" - 16, PLT	8	J1020	J1020
35	Lock nut, 3/8" - 16	4	J1025	J1025
36	Lock nut, 7/16" - 14, PLT	4	J1034	---
	Lock nut, 1/2" - 13, PLT	4	---	J1042
37	Nut, 1/2" - 13, PLT	2	J1040	J1040
38	Nut, 3/4" - 10, PLT	1	J1051	J1051
39	Flat washer, 5/16", PLT	12	J1111	J1111
40	Split lock washer, 5/16", PLT	12	J1200	J1200
41	Split lock washer, 3/8", PLT	2	J1205	J1205
42	Split lock washer, 1/2", PLT	2	J1215	J1215
43	Hairpin clip, .120 x 2.5	2	J5412	J5412
44	Screw, 5/16 - 18 x 1/2", PLT, SL	4	J0519	J0519

20° INCLINE AUGER
10" to 12"

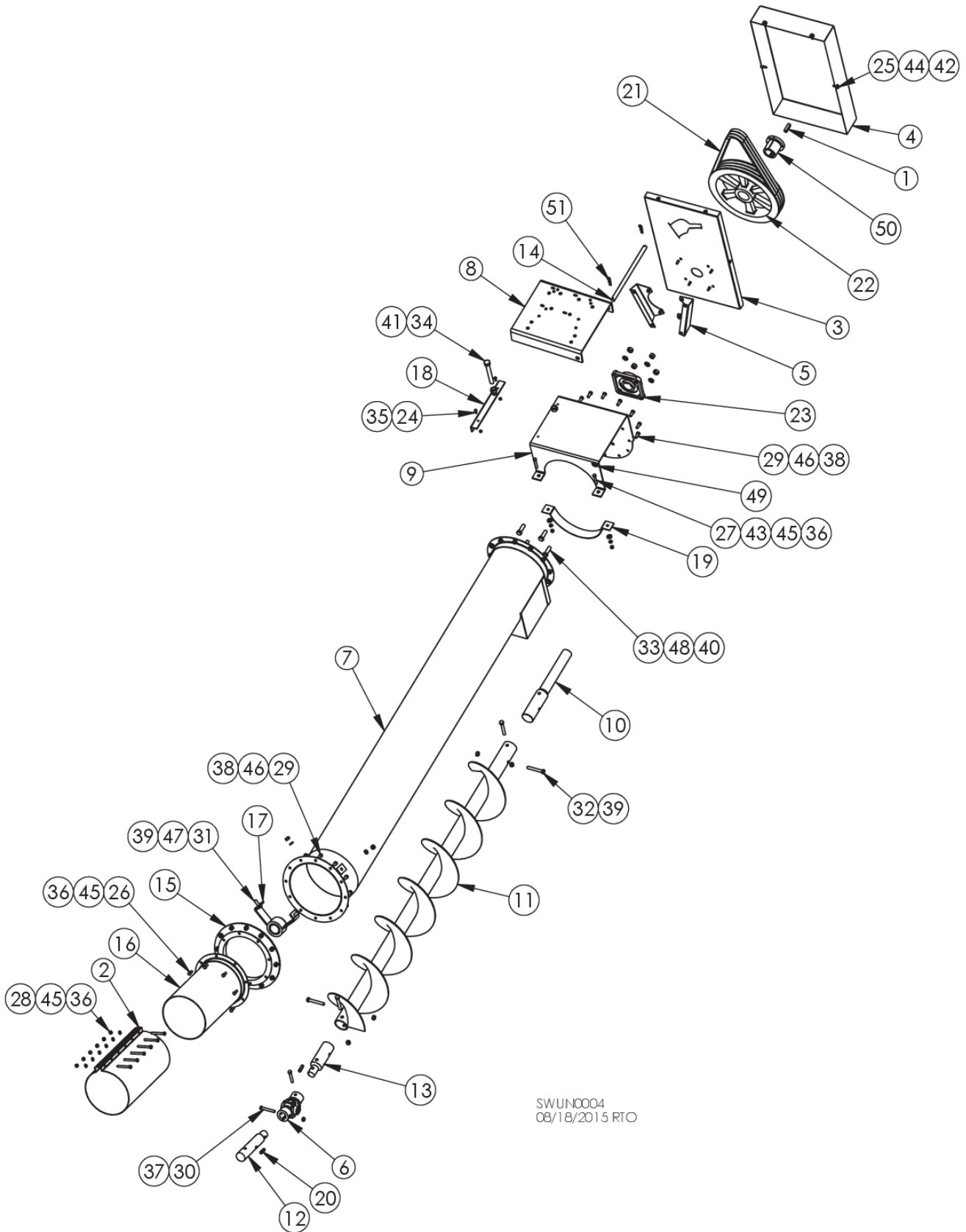

SWUN0004
08/18/2015 RTO

20° INCLINE AUGER PARTS LIST

REF. #	DESCRIPTION	QTY.	COMP. #
1	Key, 1/2 x 2"	1	D1682
2	Connector sleeve, 10 x 18"	1	E5425
3	Inner shield	1	E5972
4	Outer shield	1	E5973
5	Shield bracket	2	E5975
6	U-joint	1	E5985
7	12" horizontal tube weldment	1	E5991-01
8	Motor mount	1	E5992
9	Tube mount	1	E5993
10	Unload shaft	1	E54143
11	Flighting, 12"	1	E56231
12	Support shaft	1	E56241
13	Auger to knuckle shaft	1	E56572
14	Pivot rod	1	E57441
15	Adapter ring	1	E59431
16	Connector sleeve	1	E59441
17	Bushing support	1	E59471
18	Motor mount brace	1	E59921
19	Half band, 12"	1	EE412
20	Key, 3/8 x 1-5/8"	2	G5316
21	Belt, BX63, COG	3	J0239
22	Pulley, 15.4", triple "B" groove	1	J0396
23	Flange bearing, 2", 4-bolt	1	J00493
24	Bolt, 1/4 - 20 x 3/4"	2	J0505
25	Bolt, 5/16 - 18 x 1", PLT, GR5	8	J0527
26	Screw, 3/8 - 16 x 1", PLT	8	J0606
27	Hex screw, 3/8 - 16 x 2-1/2", PLT	2	J0655
28	Bolt, 3/8 - 16 x 3", PLT, GR5	6	J0660
29	Screw, 7/16 - 14 x 1", GR5, PLT	24	J0695
30	Bolt, 7/16 - 14 x 3"	2	J0722
31	Screw, 1/2 - 13 x 1-1/2", PLT	2	J0730
32	Screw, 1/2 - 13 x 3-1/2, GR5	4	J0754
33	Screw, 5/8 - 11 x 2", PLT, GR5	4	J0791
34	Screw, 3/4-10 x 6", PLT, GR5, tap	1	J0824
35	Lock nut, 1/4 - 20, PLT	2	J0992
36	Hex nut, 3/8" - 16, PLT	16	J1020
37	Lock nut, 7/16" - 14, PLT	2	J1034
38	Hex nut, 7/16" - 14, PLT	24	J1035
39	Lock nut, 1/2" - 13, PLT	6	J1042
40	Nut, 5/8" - 11	4	J1046
41	Nut, 3/4" - 10, PLT	1	J1051
42	Flat washer, 5/16", PLT	8	J1111
43	Flat washer, 3/8", PLT	2	J1117
44	Split lock washer, 5/16", PLT	8	J1200
45	Lock washer, 3/8", PLT	16	J1205
46	Split lock washer, 7/16", PLT	24	J1210
47	Lock washer, 1/2", PLT	2	J1215
48	Split lock washer, 5/8"	4	J1218
49	Machine bushing, 3/4 x 1-1/4", 14ga	2	J1260
50	Taper lock bushing, 2"	1	J04310
51	Hairpin clip	2	J5412

6" SWEEPWAY CENTER SUMP

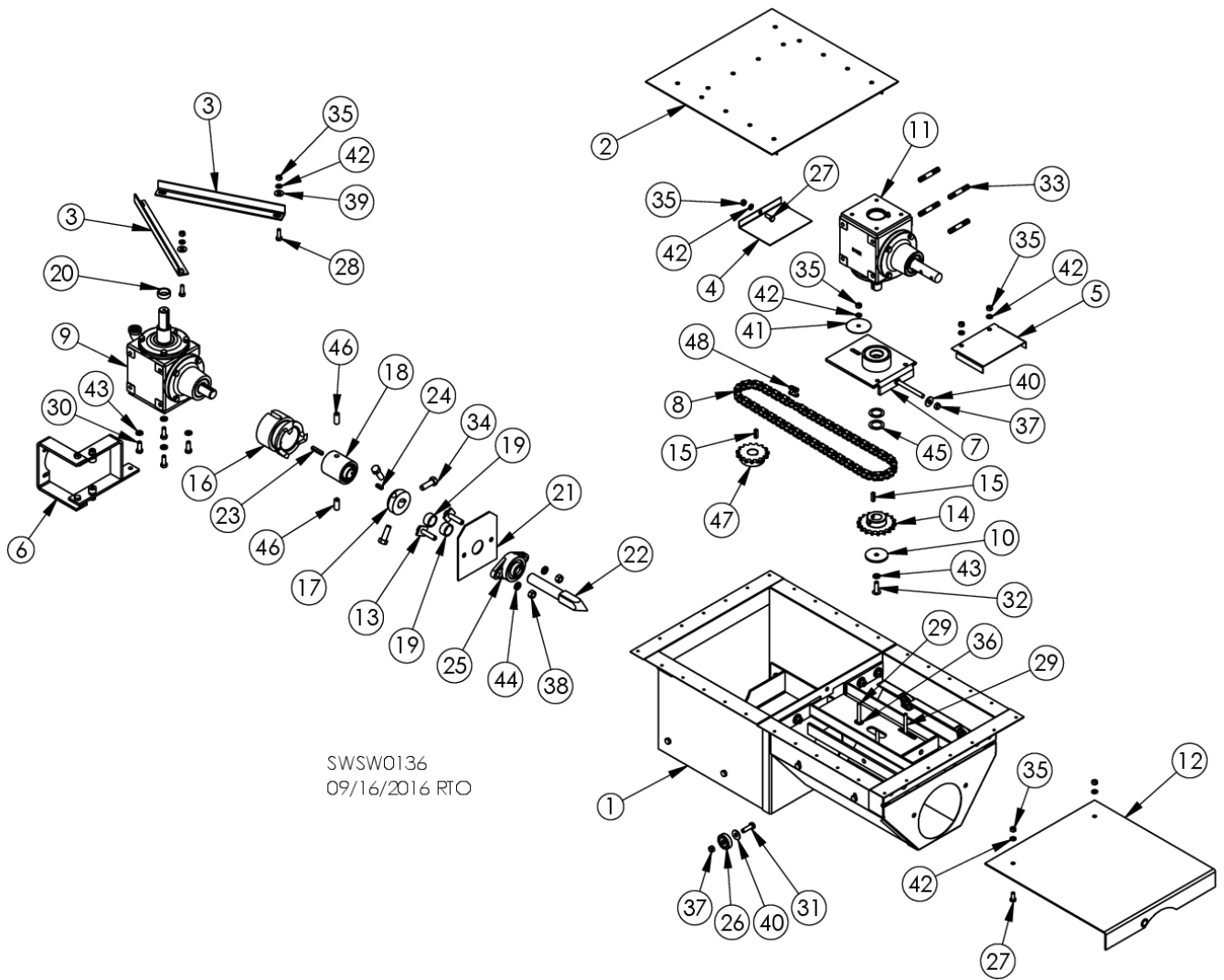

SWSW0136
09/16/2016 RTO

6" SWEEPWAY CENTER SUMP PARTS LIST

REF. #	DESCRIPTION	QTY.	6" COMP. #
1	Center sump shell	1	E5300
2	Center sump cover	1	E5306
3	Center sump brace	2	E5308
4	Chain cover	1	E5309
5	Gearbox support cover	1	E5312
6	Clutch shifter arm assembly	1	E5313
7	Top gearbox bearing support slide plate w/ bearings	1	E5317
8	#50 chain, 73 links & 1 connector link	1	E5319
9	Lower gearbox	1	E5320
10	Spacer washer, 3/8" ID, 2-1/4" OD	1	E5324
11	Top gearbox	1	E5325**
12	Slide gate	1	E5476
13	Bolt, 7/16 - 14 x 2"	2	E5570
14	Sprocket, 1" bore, 50B18	1	E5837*
15	Key, 1/4" sq. x 1"	2	E5915
16	Three-tooth engaging clutch	1	E60011
17	3-bolt clutch base	1	E6002-01
18	Clutch base w/ set & pilot bearing, 2 bolt	1	E60031
19	Clutch spacer, 5/8" long	2	E60041
20	Clutch spacer, 7/16" long	1	E60042
21	Mounting plate	1	E6005
22	Square-end shaft	1	E6006
23	Key, 1/4" x 1-1/2"	1	E9007
24	Key, 1/4" x 3/4"	1	G7508
25	1" flange bearing	1	J0003
26	Roller bearing 1-1/2", 3/8" bore	6	J0045
27	Bolt, 5/16 - 18 x 3/4"	3	J0520
28	Screw, 5/16 - 18 x 1"	2	J0527
29	Carriage bolt, 5/16 - 18 x 2-1/2"	3	J0589
30	Bolt, 3/8 - 16 x 1"	4	J0606
31	Bolt, 3/8 - 16 x 1-1/4"	2	J0616
32	Bolt, 3/8 - 16 x 1-1/4", zinc plated	1	J06161
33	Stud bolt, 7/16 - 14 x 2-3/4"	4	J07211
34	Bolt, 1-1/2 x 1/2"	3	J0730
35	Hex nut, 5/16" - 18	8	J1002
36	Flat nut, 5/16" - 18	1	J1009
37	Lock nut, 3/8" - 16	7	J1025
38	Hex nut, 7/16" - 14	2	J1035
39	Flat washer, 5/16"	2	J1111
40	Flat washer, 3/8"	7	J1117
41	Washer, 2-1/2" OD, 3/8" ID, 14ga	1	J1140
42	Split lock washer, 5/16"	8	J1200
43	Split lock washer, 3/8"	5	J1205
44	Split lock washer, 7/16"	2	J1210
45	Machine bushing, 1", 18ga	2	J1266
46	Allen-head setscrew, 1/2 x 1-1/4"	2	J1390
47	Sprocket, 50B15H, 1" bore w/ keyway	1	J1665
48	Chain connector link, #50	1	J1760

*Order E58371 to receive setscrews with sprocket

**Order E53393 to receive assembled gearbox, bearing plate & sprocket

8" SWEEPWAY CENTER SUMP

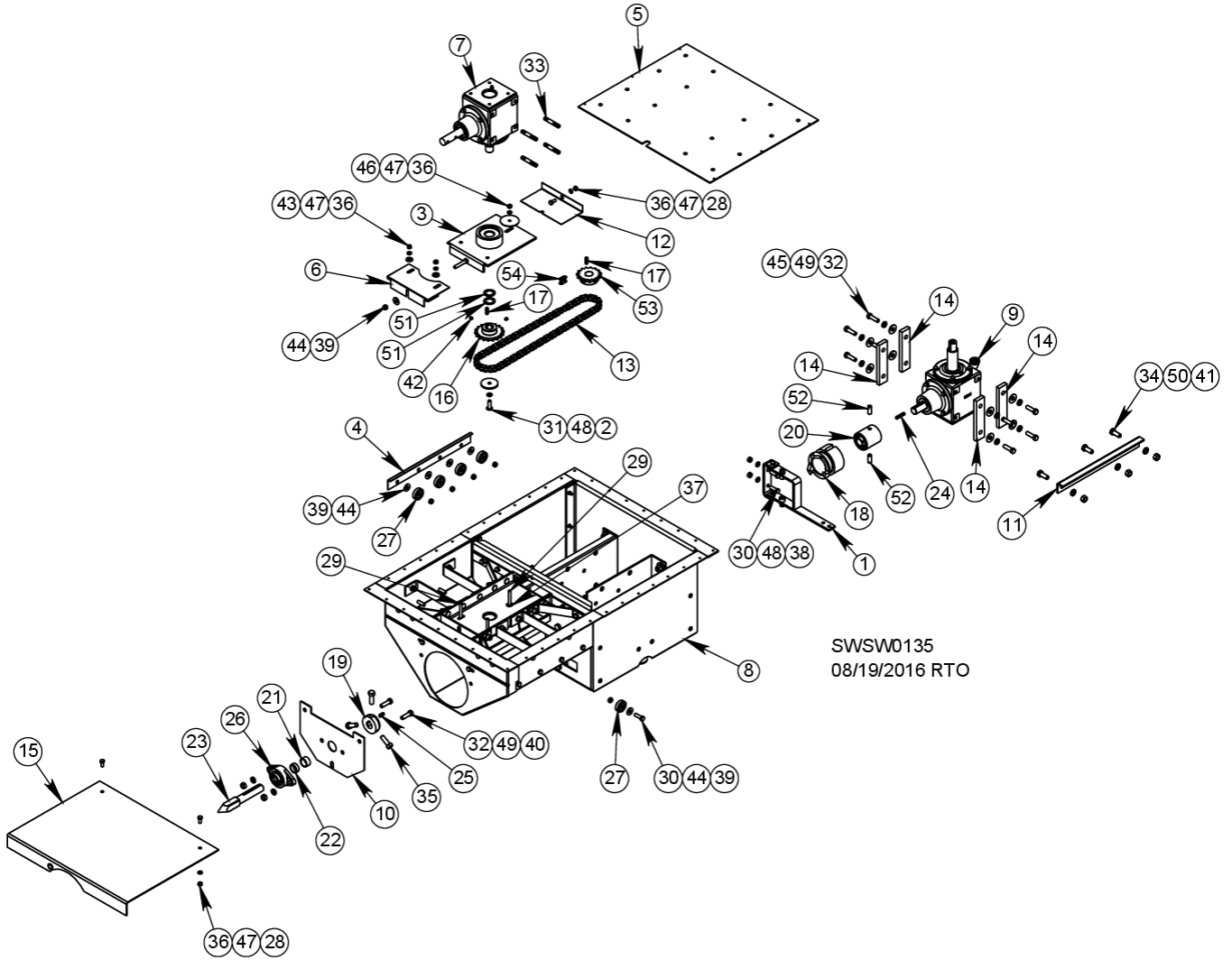

SWSW0135
08/19/2016 RTO

8" SWEEPWAY CENTER SUMP PARTS LIST

REF. #	DESCRIPTION	QTY.	8" COMP. #
1	Clutch shifter arm assembly	1	E53132
2	Spacer washer, 3/8" ID, 2-1/4" OD	1	E5324
3	Weld support plate w/ snap ring, 10"	1	E5339
4	Side gate rail	2	E5350-14
5	Sump cover	1	E5354
6	Gearbox support cover	1	E5357
7	Top gearbox	1	E5374**
8	Center sump shell	1	E5376
9	Lower gearbox	1	E5378
10	Mounting plate	1	E53871
11	Gearbox support angle brace	1	E53874
12	Chain cover	1	E53875
13	#50 chain, 75 links	1	E53876
14	Lower gearbox spacer bar	4	E53877
15	Slide gate	1	E5477
16	Sprocket, 50B18, 1" bore	1	E5837*
17	Key, 1/4 sq. x 1"	2	E5915
18	Three-tooth engaging clutch	1	E60011
19	3-bolt clutch base	1	E6002-01
20	Clutch base w/ set & pilot bearing, 2 bolt	1	E60031
21	Clutch spacer, 5/8" long	1	E60041
22	Clutch spacer, 7/16" long	1	E60042
23	Square-end shaft	1	E6006
24	Key, 1/4 x 1-1/2"	1	E9007
25	Key, 1/4" x 3/4"	1	G7508
26	1" flange bearing	1	J0003
27	Roller bearing 1-1/2", 3/8" bore	10	J0045
28	Bolt, 5/16 - 18 x 3/4"	3	J0520
29	Carriage bolt, 5/16 - 18 x 2-1/2"	3	J0589
30	Bolt, 3/8 - 16 x 1-1/4"	4	J0616
31	Bolt, 3/8 - 16 x 1-1/4", zinc plated	1	J06161
32	Screw, 7/16 - 14 x 1-1/2"	10	J0710
33	Stud bolt, 7/16 - 14 x 2-3/4"	4	J07211
34	Screw, 1/2 - 13 x 1-1/4"	3	J0728
35	Bolt, 1-1/2 x 1/2"	3	J0730
36	Hex nut, 5/16" - 18	6	J1002
37	Flat nut, 5/16" - 18	1	J1009
38	Hex nut, 3/8" - 16	2	J1020
39	Lock nut, 3/8" - 16	11	J1025
40	Hex nut, 7/16" - 14	2	J1035
41	Hex nut, 1/2" - 13	3	J1040
42	Setscrew, 5/16" - 18	2	J1080
43	Flat washer, 5/16"	2	J1111
44	Flat washer, 3/8"	11	J1117
45	Flat washer, 7/16"	8	J1120
46	Washer, 2-1/2" OD, 3/8" ID, 14ga	1	J1140
47	Split lock washer, 5/16"	6	J1200
48	Split lock washer, 3/8"	3	J1205
49	Split lock washer, 7/16"	10	J1210
50	Lock washer, 1/2"	3	J1215
51	Machine bushing, 1", 18ga	2	J1266
52	Allen-head setscrew, 1/2 x 1-1/4"	2	J1390
53	Sprocket, 50B15H, 1" bore w/ keyway	1	J1665
54	#50 chain connector link	1	J1760

*Order E58371 to receive setscrews with sprocket

**Order E53392 to receive assembled gearbox, bearing plate & sprocket

10" SWEEPWAY CENTER SUMP

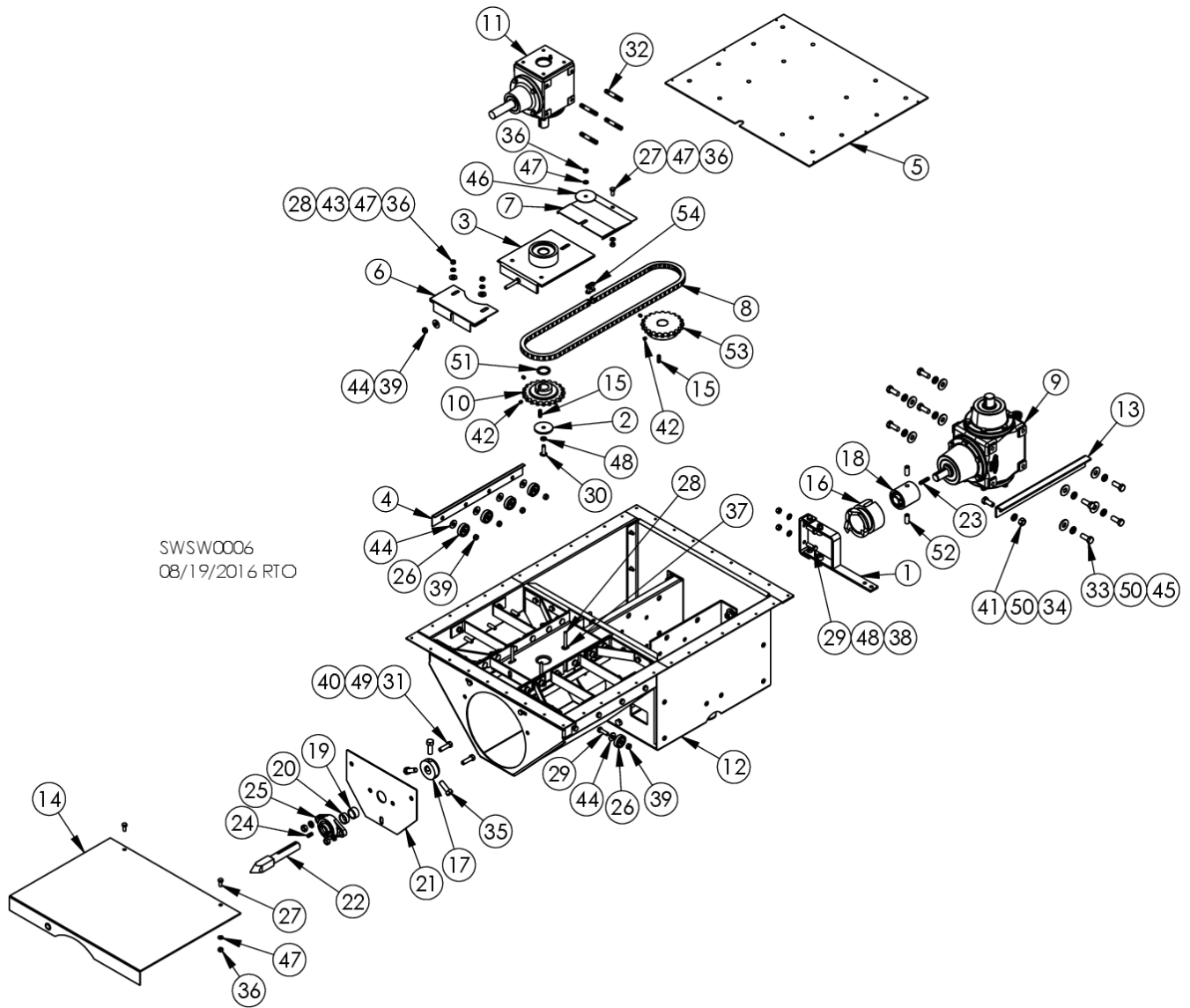

SWSW0006
08/19/2016 RTO

10" SWEEPWAY CENTER SUMP PARTS LIST

REF. #	DESCRIPTION	QTY.	8" COMP. #
1	Clutch shifter arm assembly	1	E53132
2	Spacer washer, 3/8" ID, 2-1/4" OD	1	E5324
3	Weld support plate w/ snap ring, 10"	1	E5339
4	Side gate rail	2	E5350-14
5	Sump cover	1	E5354
6	Gearbox support cover	1	E5357
7	Chain cover	1	E5358
8	#60 chain, 73 links	1	E5359-01
9	Lower gearbox	1	E5360
10	Sprocket, 60B20, 1.1811" bore	1	E5373*
11	Top gearbox	1	E5375**
12	Center sump shell	1	E5377
13	Gearbox support angle brace	1	E53874
14	Slide gate	1	E5478
15	Key, 1/4 sq. x 1"	2	E5915
16	Three-tooth engaging clutch	1	E60011
17	3-bolt clutch base	1	E6002-01
18	Clutch base w/ set & pilot bearing, 2 bolt	1	E60031
19	Clutch spacer, 5/8" long	1	E60041
20	Clutch spacer, 7/16" long	1	E60042
21	Mounting plate	1	E60051
22	Square-end shaft	1	E6018
23	Key, 1/4 x 1-1/2"	1	E9007
24	Key, 1/4" x 3/4"	1	G7508
25	1" flange bearing	1	J0003
26	Roller bearing 1-1/2", 3/8" bore	10	J0045
27	Bolt, 5/16 - 18 x 3/4"	3	J0520
28	Carriage bolt, 5/16 - 18 x 2-1/2"	3	J0589
29	Bolt, 3/8 - 16 x 1-1/4"	4	J0616
30	Bolt, 3/8 - 16 x 1-1/4", zinc plated	1	J06161
31	Screw, 7/16 - 14 x 1-1/2"	2	J0710
32	Stud bolt, 7/16 - 14 x 2-3/4"	4	J07211
33	Screw, 1/2 - 20 x 1-1/4"	8	J0724
34	Screw, 1/2 - 13 x 1-1/4"	1	J0728
35	Bolt, 1-1/2 x 1/2"	3	J0730
36	Hex nut, 5/16" - 18	6	J1002
37	Flat nut, 5/16" - 18	1	J1009
38	Hex nut, 3/8" - 16	2	J1020
39	Lock nut, 3/8" - 16	11	J1025
40	Hex nut, 7/16" - 14	2	J1035
41	Hex nut, 1/2" - 13	1	J1040
42	Setscrew, 5/16" - 18	4	J1080
43	Flat washer, 5/16"	2	J1111
44	Flat washer, 3/8"	11	J1117
45	Flat washer, 1/2"	8	J1125
46	Washer, 2-1/2" OD, 3/8" ID, 14ga	1	J1140
47	Split lock washer, 5/16"	6	J1200
48	Split lock washer, 3/8"	3	J1205
49	Split lock washer, 7/16"	2	J1210
50	Lock washer, 1/2"	9	J1215
51	Machine bushing, 30mm ID x 4mm OD	1	J1268
52	Allen-head setscrew, 1/2 x 1-1/4"	2	J1390
53	Sprocket, 60B20, 1-1/4" bore	1	J1695
54	#60 chain connector link	1	J1775

*Order E53731 to receive setscrews with sprocket

**Order E53391 to receive assembled gearbox, bearing plate & sprocket

INDEPENDENT INTERMEDIATE SUMP, PARTS LIST
8" & 10"

SWSW0201
 05/24/2018 RTO

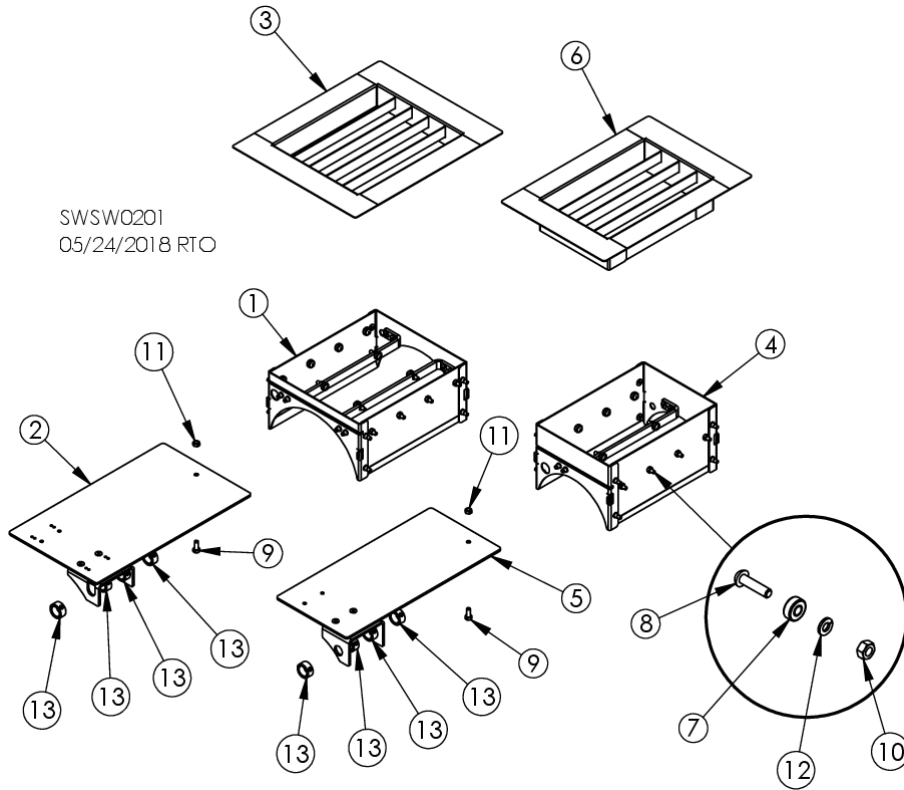

REF. #	DESCRIPTION	QTY.	COMP. #
1	Sump bottom, 10"	1	E53951
2	Slide gate, 10" sump	1	E53963
3	Sump top, 10"	1	E53964
4	Sump bottom, 8"	1	E53981
5	Slide gate, 8" sump	1	E53987
6	Sump top, 8"	1	E53989
7	Bearing, 1/4" ID, 5/8" OD	10	J0016
8	Screw, 1/4 – 20 x 1"	10	J05081
9	Screw, 5/16 – 18 x 3/4"	1	J0520
10	Hex nut, 1/4" – 20	10	J0990
11	Lock nut, 5/16" – 18	1	J1010
12	Lock washer, 1/4",	10	J1195
13	Shaft collar, 7/8"	4	J1330

6", 8" & 10" SWEEPWAY INTERMEDIATE SUMPS, PARTS LIST

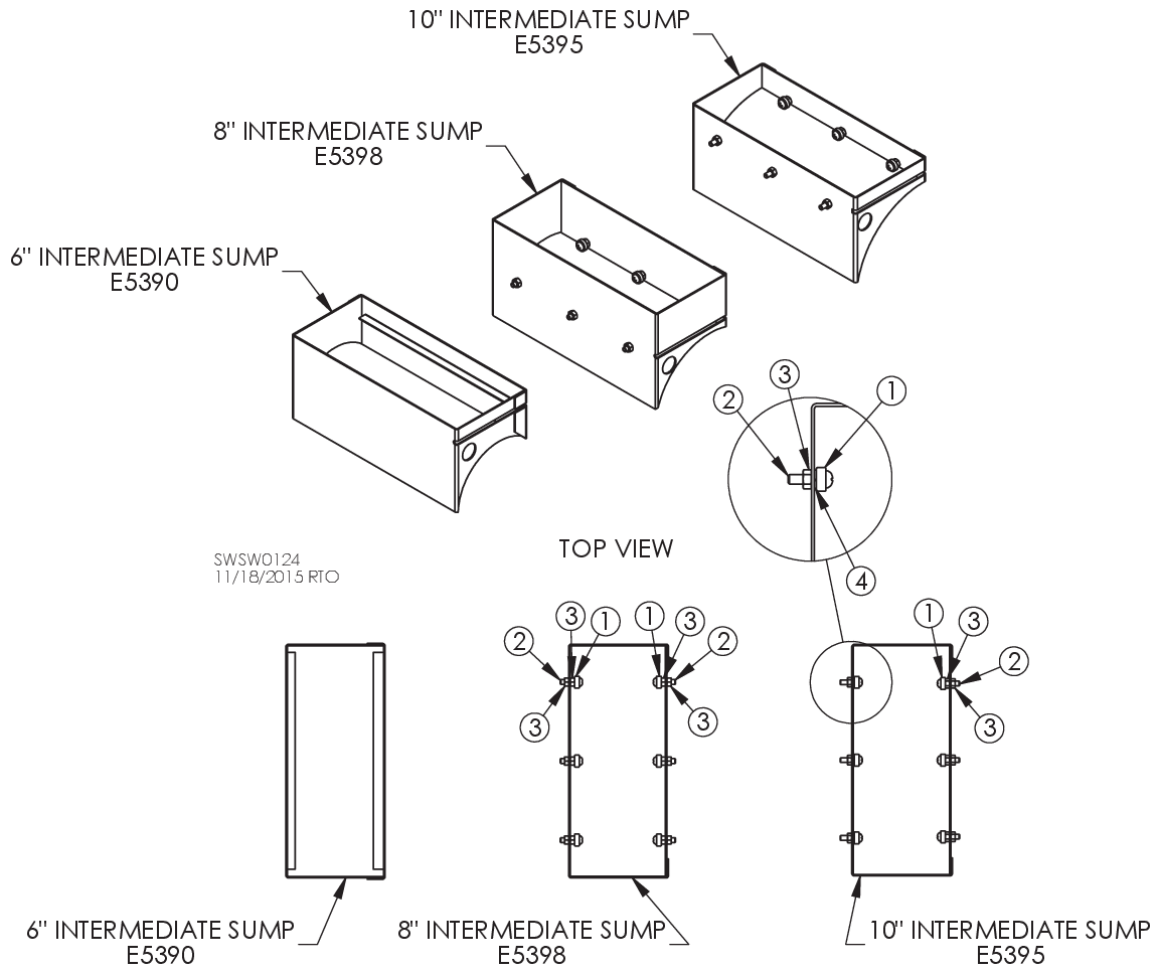

REF. #	DESCRIPTION	QTY.	COMP. #
1	Bearing, 1/4" ID, 5/8" OD	*	J0016
2	Screw, 1/4 - 20 x 1"	*	J05081
3	Hex nut, 1/4" - 20	*	J0990
4	Lock washer, 1/4"	*	J1195

* QTY. varies with sump size

6" & 8" SWEEPWAY TOP GEARBOX, PARTS LIST

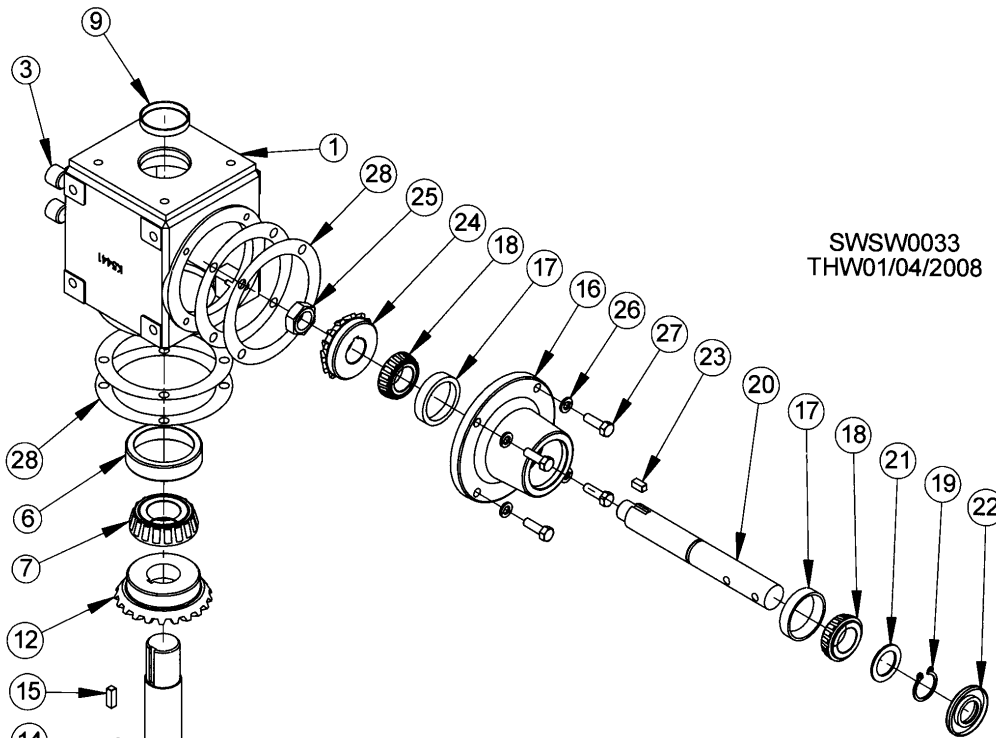

REF. #	DESCRIPTION	QTY.	COMP. #
	Complete gearbox, sump, top 6", 8" (prior to 2011)		E5325
	Complete gearbox, sump, top 8", 2011		E5374
1	Gearbox case, two hole	1	F9004
2	Snap ring, 1.37, 5160-137	1	J3589
3	Plug, sunk head, 1/2" hex center	2	J2615
4	Cup, 2-23/32" OD, 14276	1	J0115
5	Tapered bearing, 14137A, Timken, 1-3/8"	1	J0120
6	Bearing cup, Timken, 02820	1	J0125
7	Tapered bearing, 1-1/4", .94, 02875	1	J0130
8	Seal, 1-3/8 x 2.129, R/C, 13650	1	J7010
9	Soft plug, 1-7/8", PC	1	J6980
10	Machine bushing, 1-3/8", 10ga, N rim	1	J1275
11	Open end plate w/ grease zerk cup & SI	1	E59021
12	Gear, 21-tooth w/ 1-1/4" bore	1	F4742
13	Drive-in grease zerk, 1/4"	1	J3605
14	Shaft, 8-3/8 x 1-3/8" w/ keyway, 6", 8" (prior to 2011)	1	E5901
	Shaft, 8.601, 1-3/8" w/ keyway, 8", 2011	1	E5908
15	Square key, 1/4" x 13/16"	1	J3619
16	Gear box hub	1	F9007
17	Bearing cup, L-44610	2	J0105
18	Tapered bearing, 14137A, Timken, 1-3/8"	2	J0111
19	Snap ring, 1.00, 329, Eaton	1	J3584
20	Upper gearbox connector shaft, 1 x 8"	1	E5903
21	Machine bushing, 1", 1ga, N rim	1	J1265
22	Seal, 1.000 x 2.004, R/C, 10124	1	J6993
23	Square key, 1/4 x 9/16"	1	J3618
24	Small gear, (14 teeth)	1	F4740
25	Thin nylon lock nut, 3/4" - 16, PLT	1	J1055
26	Split lock washer, 5/16", PLT	8	J1200
27	Screw, 5/16 - 18 X 1", PLT, GR5	8	J0527
28	Shim, 3.88 x 5.12 x 0.003	As needed	J7090
	Shim, 3.88 x 5.12 x 0.010	As needed	J70901

6" & 8" SWEEPWAY LOWER GEARBOX, PARTS LIST

REF. #	DESCRIPTION	QTY.	COMP. #
	Complete gearbox, lower sump, 6", 8" (prior to 2011)		E5320
	Complete gearbox, lower sump, 8", 2011		E5378
1	Shaft, 1-3/8" main, lower sump, 6", 8" (prior to 2011)	1	E5900
	Shaft, 10-7/16", 13/8" w/ keyway, 8", 2011	1	E5927
2	Open end plate w/ grease zerk & cup	1	E59021
3	Lower hub, 6" & 8" complete	1	F9015
	Hub only		F9007
4	Seal, 1-3/8"	1	J7010
5	1" keyway shaft x 6-1/2", lower	1	F4738
6	Machine bushing, 1-3/8", 10ga	1	J1275
7	Bearing, 14137A	1	J0120
8	Bearing, 02875	1	J0130
9	Bearing, L44643	2	J0110
10	Bearing cup, L44610	2	J0105
11	Bearing cup, 02820	1	J0125
12	Bearing cup, 14276	1	J0115
13	Machine bushing, 1", 14ga	1	J1265
14	Street elbow, 1/2 x 90°, upper sump	1	J2520
15	Lock nut, 3/4" - 16 thin nylon	1	J1055
16	Gear, 21 teeth 1-1/4" bore	1	F4742
17	Gear, 14 teeth	1	F4740
18	Snap ring, 1"	1	J3584
20	Gearbox case, complete w/ grease zerk	1	F90041
	Gearbox case only		F9004
21	Grease zerk	1	J3605
22	1" seal	1	J6993
23	Soft plug, 1-7/8"	1	J6980
24	Square key, 1/4 x 13/16"	2	J3619
25	Black plug, 1/2"	1	J2615
26	1/2" center sunk head vented plug	1	J2616
27	Plastic shims, .003 thick	As needed	J7090
	Plastic shims, .010 thick	As needed	J70901
28	Snap ring, 1-3/8"	1	J3589
29	Screw, 5/16 - 18 x 1", GR5 (Not shown)	6	J0527
30	Screw, 5/16 - 18 x 1-1/4", GR5 (Not shown)	2	J0550
31	Lock washer, 5/16 (Not shown)	8	J1200
32	Square key, 1/4 x 9/16"	1	J3618

SWSW0002
THW01/07/2007

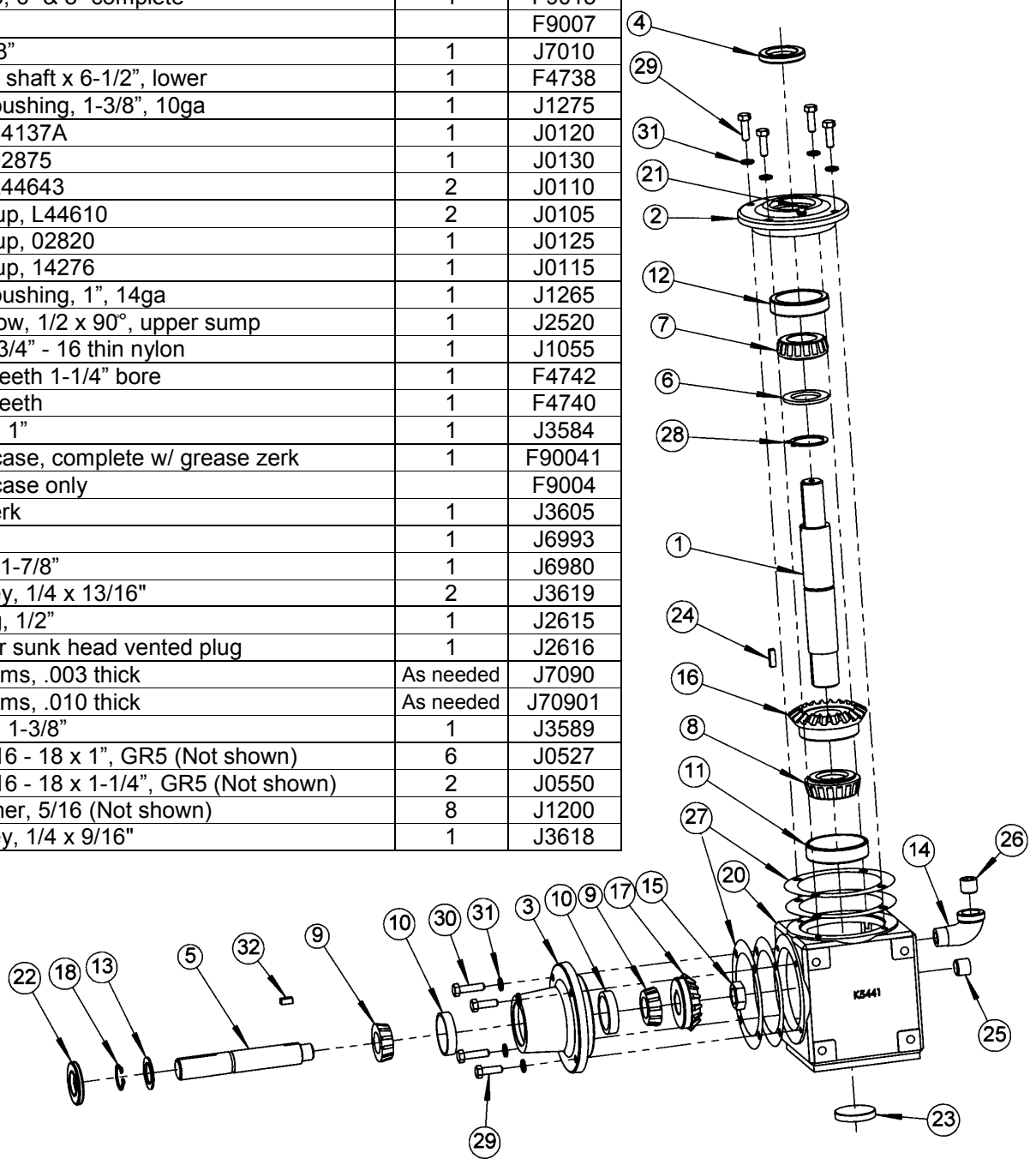

10" SWEEPWAY TOP GEARBOX, PARTS LIST

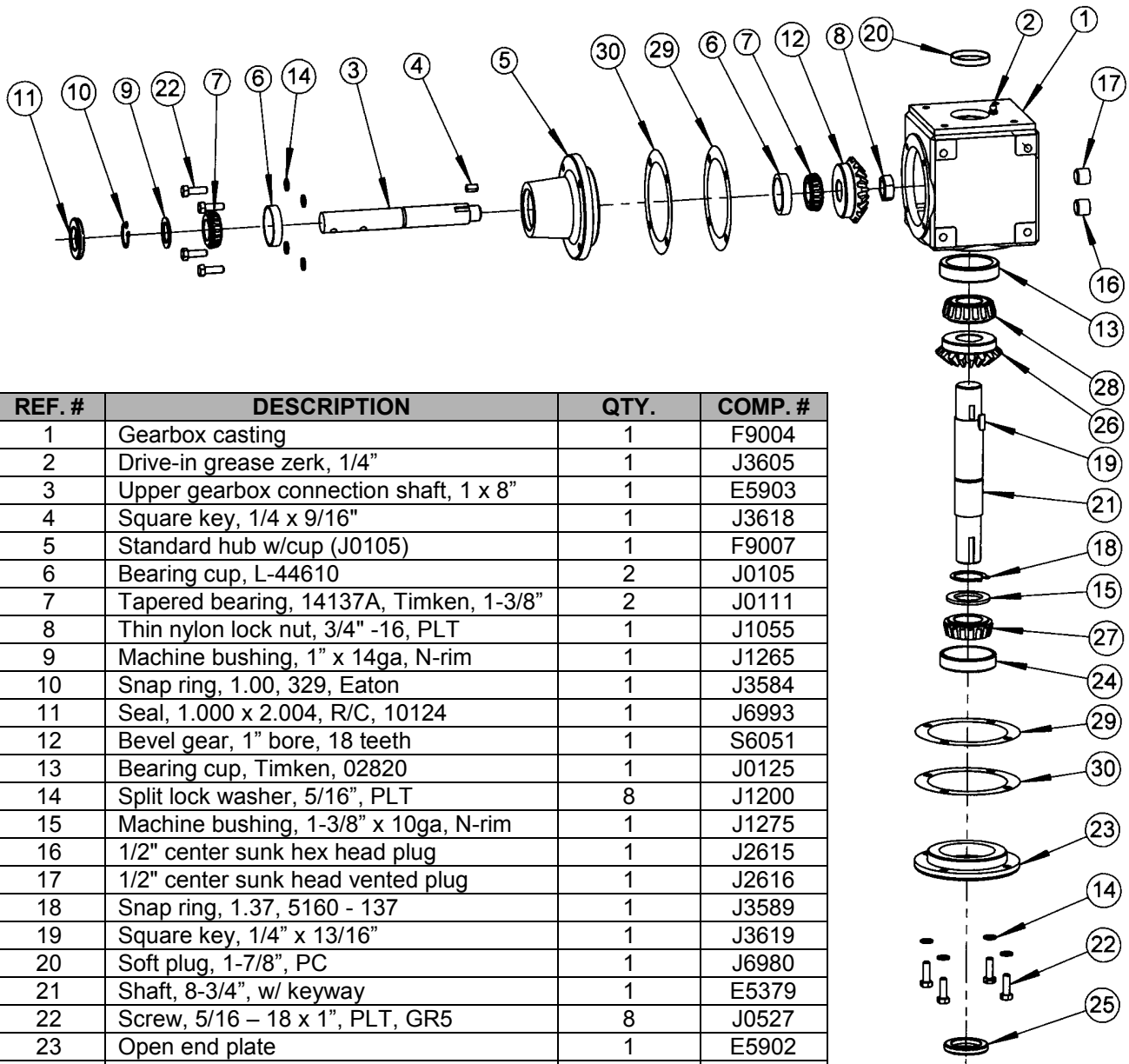

REF. #	DESCRIPTION	QTY.	COMP. #
1	Gearbox casting	1	F9004
2	Drive-in grease zerk, 1/4"	1	J3605
3	Upper gearbox connection shaft, 1 x 8"	1	E5903
4	Square key, 1/4 x 9/16"	1	J3618
5	Standard hub w/cup (J0105)	1	F9007
6	Bearing cup, L-44610	2	J0105
7	Tapered bearing, 14137A, Timken, 1-3/8"	2	J0111
8	Thin nylon lock nut, 3/4" -16, PLT	1	J1055
9	Machine bushing, 1" x 14ga, N-rim	1	J1265
10	Snap ring, 1.00, 329, Eaton	1	J3584
11	Seal, 1.000 x 2.004, R/C, 10124	1	J6993
12	Bevel gear, 1" bore, 18 teeth	1	S6051
13	Bearing cup, Timken, 02820	1	J0125
14	Split lock washer, 5/16", PLT	8	J1200
15	Machine bushing, 1-3/8" x 10ga, N-rim	1	J1275
16	1/2" center sunk hex head plug	1	J2615
17	1/2" center sunk head vented plug	1	J2616
18	Snap ring, 1.37, 5160 - 137	1	J3589
19	Square key, 1/4" x 13/16"	1	J3619
20	Soft plug, 1-7/8", PC	1	J6980
21	Shaft, 8-3/4", w/ keyway	1	E5379
22	Screw, 5/16 - 18 x 1", PLT, GR5	8	J0527
23	Open end plate	1	E5902
24	Cup, 2-23/32" OD 14276	1	J0115
25	Seal, 1.375 x 2.129, R/C, 13650	1	J7010
26	Bevel gear, 1-1/4" bore, 18 teeth	1	E5372
27	Tapered brng, 14137 A, Timken, 1-3/8"	1	J0120
28	Tapered bearing, 1-1/4", .94, 02875	1	J0130
29	Shim, 3.88 x 5.12 x 0.003	As needed	J7090
30	Shim, 3.88 x 5.12 x 0.010	As needed	J70901

SWSW0050
THW01/04/2008

10" SWEEPWAY LOWER GEARBOX, PARTS LIST

REF. #	DESCRIPTION	QTY.	COMP. #
1	Hub casting, HD, 1-3/8", 10", 1998	1	E5365
2	Gearbox shaft, 10"	1	E5366
3	Shaft, 8-5/16"	1	E5367
4	Key, 1/4" sq. x 1"	1	E5915
5	Lower gearbox casting, HD, 3 hole	1	F9051
6	Bevel gear, 18 tooth, 1-1/4" bore	1	F9052
7	Gear, 27-tooth, 1-3/8" bore	1	F9053
8	Closed end plate	1	F9061-01
9	Gearbox hub, 1-3/8"	1	F9065-01
10	Key, 3/8 x 1-1/4"	1	G5315
11	Bearing, 1-3/8" ID, 3872, Timken	1	J0027
12	Cup, 3-3/8" OD, 3820, 3821, Timken	1	J0028
13	Cup, 2-23/32" OD, 14276	3	J0115
14	Tapered bearing, 14137A, Timken, 1-3/8"	3	J0120
15	Screw, 3/8 - 24 x 1", PLT, GR5	18	J0612
16	Thin nylon lock nut, 1-1/8" - 12, PLT	1	J1067
17	Split lock washer, 3/8"	18	J1205
18	Machine bushing, 1-3/8 x 10ga, N-rim	1	J1275
19	Street elbow, 1/2", 90°, Sch 40	1	J2520
20	1/2" center sunk hex head plug	2	J2615
21	1/2" center sunk head vented plug	1	J2616
22	Snap ring, 1.37, 5160-137	1	J3589
23	Drive-in grease zerk, 1/4"	1	J3605
24	Seal, 1.38 ID, N, 472658	2	J7061
25	Shim, 4.625 x 6.010 x 0.003	1	J7085
26	Shim, 4.625 x 6.010 x .010	4	J7088

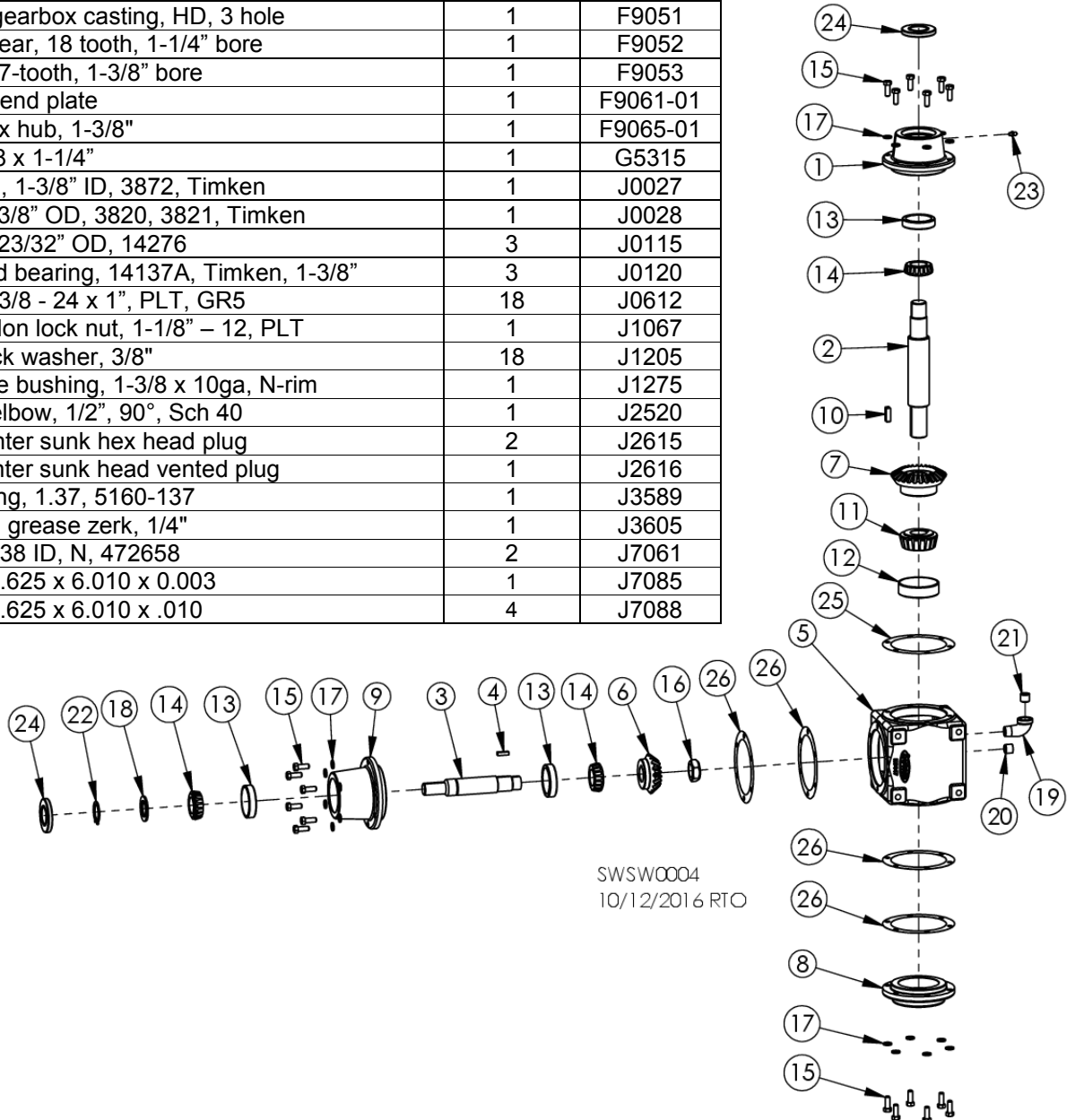

TOP GEARBOX BEARING SUPPORT SLIDE PLATE ASSY., PARTS LIST

E5317 (6")*

E5339 (8" & 10")

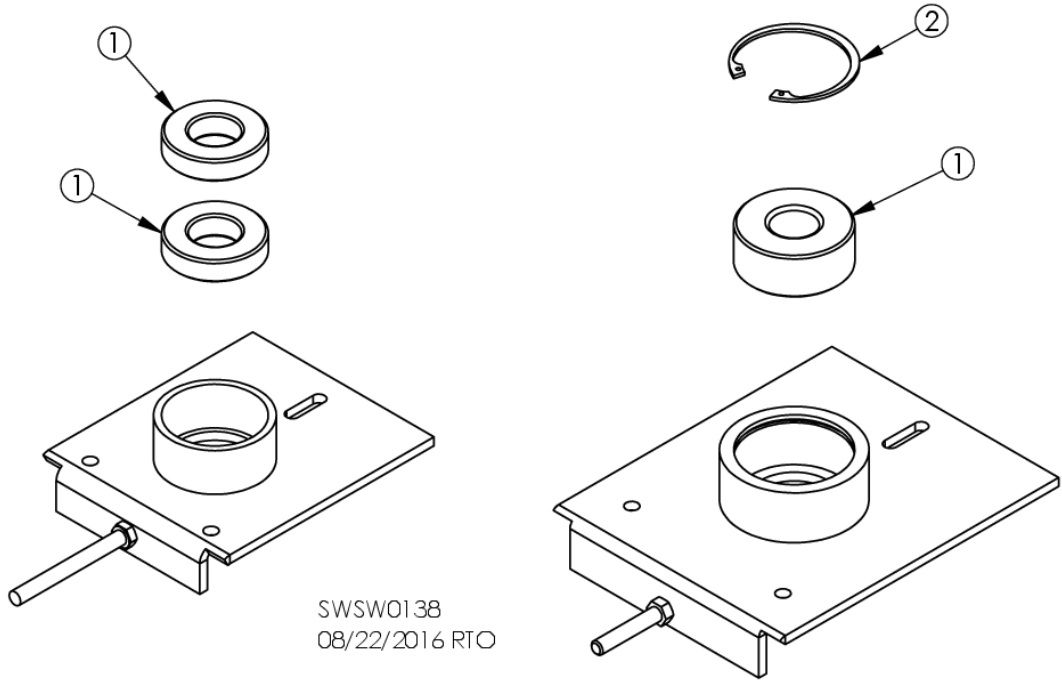

SWSW0138
08/22/2016 RTO

REF. #	DESCRIPTION	QTY.	6" COMP. #	8" & 10" COMP. #
1	Bearing, 1-1/4" ID, 2-1/2" OD	2	J0060	NA
	Bearing, 1.1811 ID, 2.8346 OD	1	NA	J00599
2	Snap ring, 2.047"	1	NA	J35991

*Also 8" prior to 2011

CLUTCH SHIFTER ARM ASSEMBLY, PARTS LIST

E5313 (6")

E53132 (8" & 10")

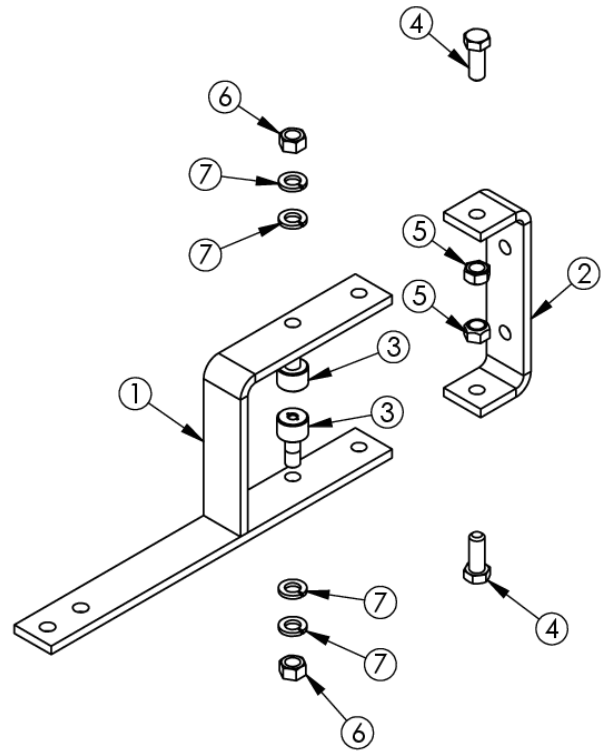
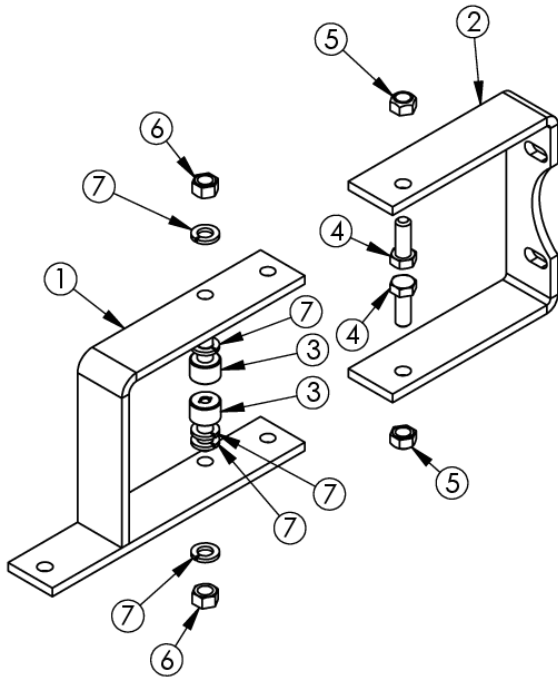

SWSW0137
08/22/2016 RTO

REF. #	DESCRIPTION	QTY.	6" COMP. #	8" & 10" COMP. #
1	Clutch arm weldment	1	E53131	NA
			NA	E5351
2	Clutch shifter support bracket	1	E5311	NA
			NA	E5352
3	Bearing, 3/4",cam follower	2	J0035	J0035
4	Screw, 3/8 -16 x 1"	2	J0606	J0606
5	Lock nut, 3/8" – 16	2	J1025	J1025
6	Hex nut, 3/8" – 24	2	J1030	J1030
7	Split lock washer, 3/8"	4	J1205	J1205

8" SWEEPWAY RACK & PINION OPENER ASSEMBLY (E5919), PARTS LIST

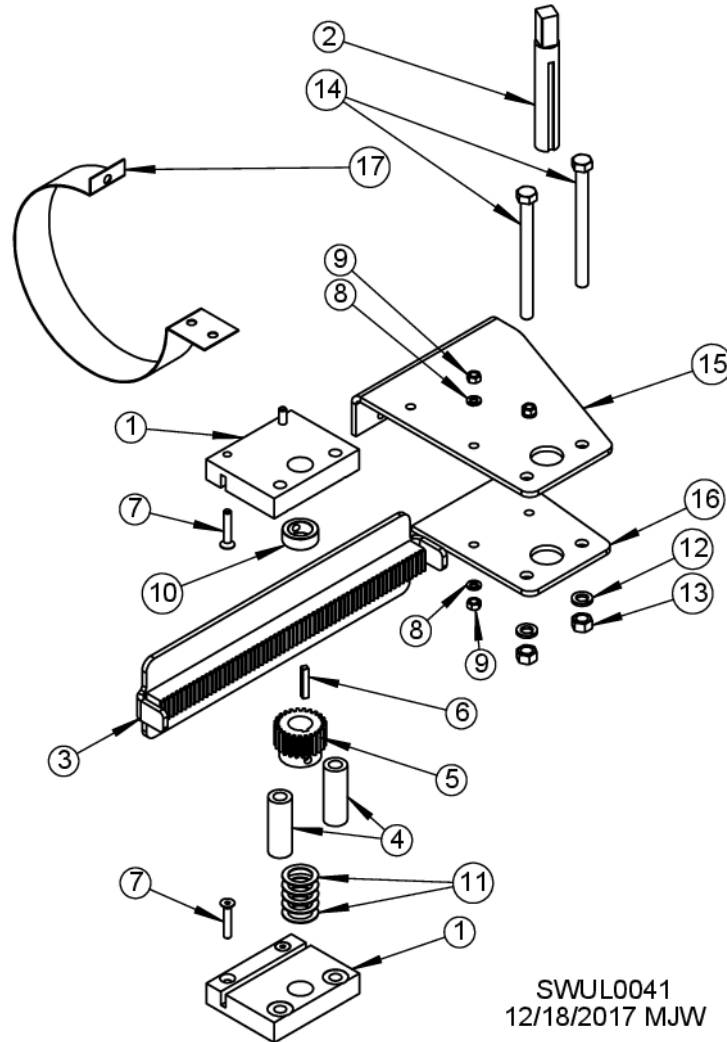

SWUL0041
12/18/2017 MJW

REF. #	DESCRIPTION	QTY.	COMP. #
1	Slide guide	2	E5962
2	Opener crank shaft	1	E5964
3	Slide plate rack weldment	1	E5916
4	Spacer	2	E5966
5	Pinion gear	1	E5961
6	Key, 1/4 x 1-1/2"	1	E9007
7	Screw, 5/16 – 18 x 1-3/4"	8	J0579
8	Split lock washer, 5/16"	8	J1200
9	Hex nut, 5/16" – 18	8	J1002
10	Shaft collar, 1"	1	J1335
11	Machine bushing, 1", 18ga	5	J1266
12	Lock washer, 1/2"	2	J1215
13	Hex nut, 1/2" – 13	2	J1040
14	Screw, 1/2 - 13 x 6"	2	J0762
15	Top frame	1	E5918
16	Bottom frame	1	E5917
17	Support strap	1	E5913

10" SWEEPWAY RACK & PINION OPENER ASSEMBLY (E5969), PARTS LIST

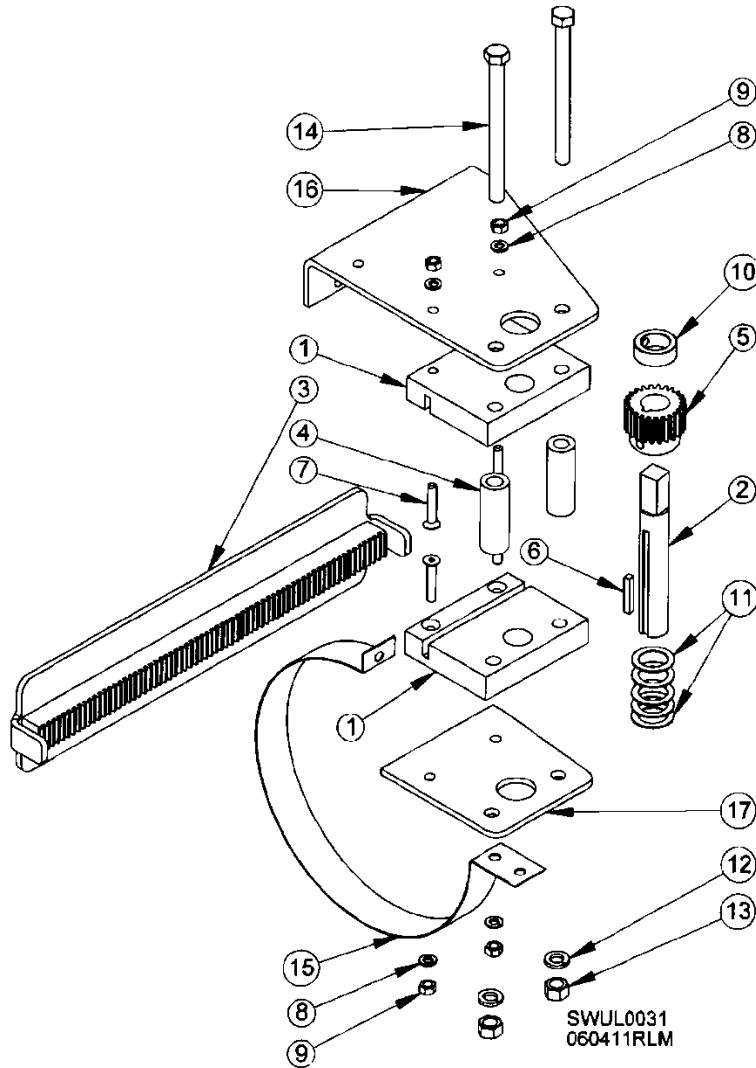

REF. #	DESCRIPTION	QTY.	COMP. #
1	Slide guide	2	E5962
2	Opener crank shaft	1	E5964
3	Slide plate rack weldment	1	E5963
4	Spacer	2	E5966
5	Pinion gear	1	E5961
6	Key, 1/4 x 1-1/2"	1	E9007
7	Screw, 5/16 – 18 x 1-3/4"	8	J0579
8	Split lock washer, 5/16"	8	J1200
9	Hex nut, 5/16" – 18	8	J1002
10	Shaft collar, 1"	1	J1335
11	Machine bushing, 1", 18ga	5	J1266
12	Lock washer, 1/2"	2	J1215
13	Hex nut, 1/2" – 13	2	J1040
14	Screw, 1/2 - 13 x 6"	2	J0762
15	Support strap	1	E5968
16	Top frame	1	E5965-02
17	Bottom frame	1	E5965-01

4-TO-1 REDUCTION DRIVE WHEEL ASSEMBLY, PARTS LIST
 Standard on all 6" sweeps and on 8" & 10" sweeps in bins up to 33' dia.

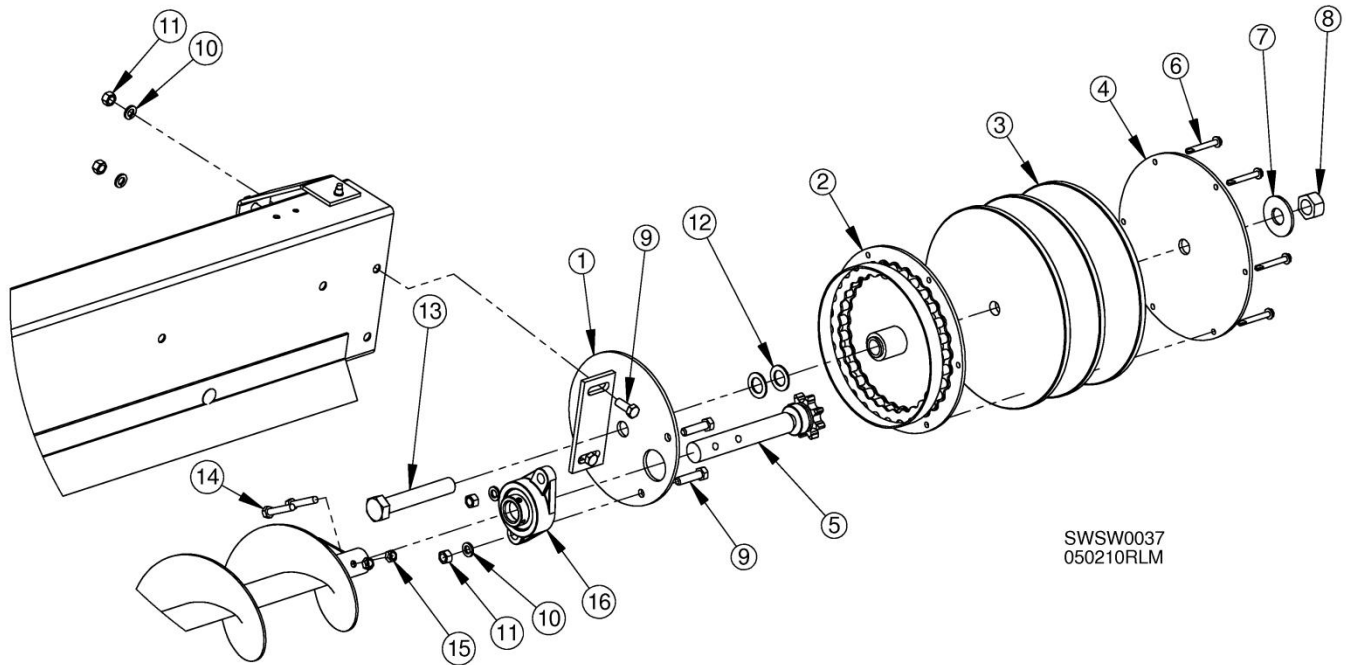

REF. #	DESCRIPTION	QTY.	6" COMP #	8" COMP. #	10" COMP. #
	Complete wheel		E6094	E6092	E6093
1	6" assembly mount, 2010	1	E6095	-	-
	8" assembly mount, split, w/ brng., 2010	1	-	E6096	-
	10" assembly mount, split, w/ brng., 2010	1	-	-	E6097
2	Back plate w/ roller, 2010	1	E6087	E6087	E6087
3	10" rubber ring, 2000	3	E60121-01	E60121-01	E60121-01
4	Back plate, 9.25" Dia., 2010	1	E6088	E6088	E6088
5	Drive shaft w/ 8-tooth sprocket	1	E6049	E6049	E6049
6	Self-drilling screw, 1/4 - 14 x 2-1/4, PLT	6	J05041	J05041	J05041
7	Flat washer, 3/4", PLT	1	J1130	J1130	J1130
8	Lock nut, 3/4" - 10, GR5	1	J1057	J1057	J1057
9	Screw, 3/8 - 16 x 1", PLT, GR5	4	J0606	J0606	J0606
10	Split lock washer, 3/8", PLT	4	J1205	J1205	J1205
11	Hex nut, 3/8" - 16, PLT	4	J1020	J1020	J1020
12	Machine bushing, 3/4 x 1-1/4", 14ga, N-rim	2	J1260	J1260	J1260
13	Screw, 3/4 - 10 x 4-1/2", PLT, GR5	1	J0817	J0817	J0817
14	Screw, 5/16 - 18 x 1-3/4", PLT, GR5	2	J0570	J0570	J0570
15	Lock nut, 5/16" - 18, PLT	2	J1010	J1010	J1010
16	1" flange bearing w/ locking collar	1	J0003	J0003	J0003

16-TO-1 REDUCTION DRIVE WHEEL ASSEMBLY, PARTS LIST

GEARBOX CROSS SECTION

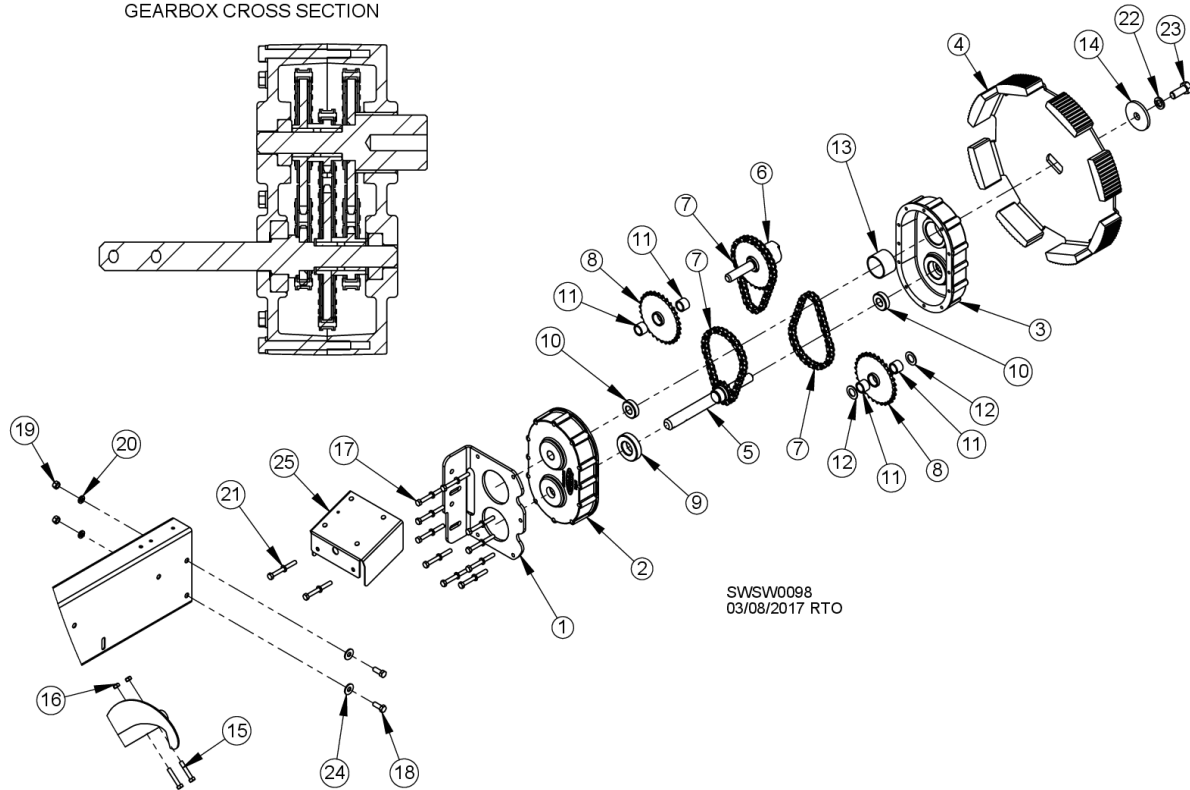

SWSW0098
03/08/2017 RTO

REF. #	DESCRIPTION	QTY.	6" COMP. #	8" COMP. #	10" COMP. #
	Complete gearbox w/ bracket	1	E7335	E7337	E7339
	Complete gearbox w/o bracket	1	E7330	E7330	E7330
1	Gearbox bracket	1	E7306	E7308	E7310
2*	Gearbox inside side cover	1	E7317	E7317	E7317
3*	Gearbox outside cover	1	E7318	E7318	E7318
4	Wheel, 17" OD	1	E7349	E7349	E7349
5	Gearbox input shaft weldment w/ sprocket	1	E7320	E7320	E7320
6	Gearbox output shaft weldment w/ sprocket	1	E7319	E7319	E7319
7	Chain, # 40, 37 links	3	E7327	E7327	E7327
8	Sprocket tree, 4A30-40A12, 1" bore	2	J7312	J7312	J7312
9	Bearing, 1-1/4" ID, 2-1/2" OD	1	J0060	J0060	J0060
10	Bearing, 3/4" ID, 1-5/8" OD	2	J00703	J00703	J00703
11	Bushing, 3/4" ID, 1-3/4" OD	4	J00745	J00745	J00745
12	Thrust washer, 3/4" ID, 1-2/4" OD	2	J00746	J00746	J00746
13	Bushing, 1-15/16" ID, 2-1/8" OD	1	J00817	J00817	J00817
14	Flat washer, 11/16"	1	E7322	E7322	E7322
15	Screw, 5/16 - 18 x 1-3/4"	2	J0570	J0570	J0570
16	Lock nut, 5/16" - 18	2	J1010	J1010	J1010
17	Screw, 5/16 - 18 x 3"	12	J05952	J05952	J05952
18	Screw, 3/8 - 16 x 1"	2	J0606	J0606	J0606
19	Hex nut, 3/8" - 16	2	J1020	J1020	J1020
20	Split lock washer, 3/8"	2	J1205	J1205	J1205
21	Split lock washer, 5/16"	12	J1200	J1200	J1200
22	Split lock washer, 5/8"	1	J1218	J1218	J1218
23	Screw, 5/8 - 11 x 1-1/2"	1	J0781	J0781	J0781
24	Flat washer, 3/8"	2	J1117	J1117	J1117
25	Gearbox reclaim shield	1	E7358	E7358	E7355

*Must be replaced together if replacement necessary

16:1 DRIVE WHEEL RECLAIM SHIELD

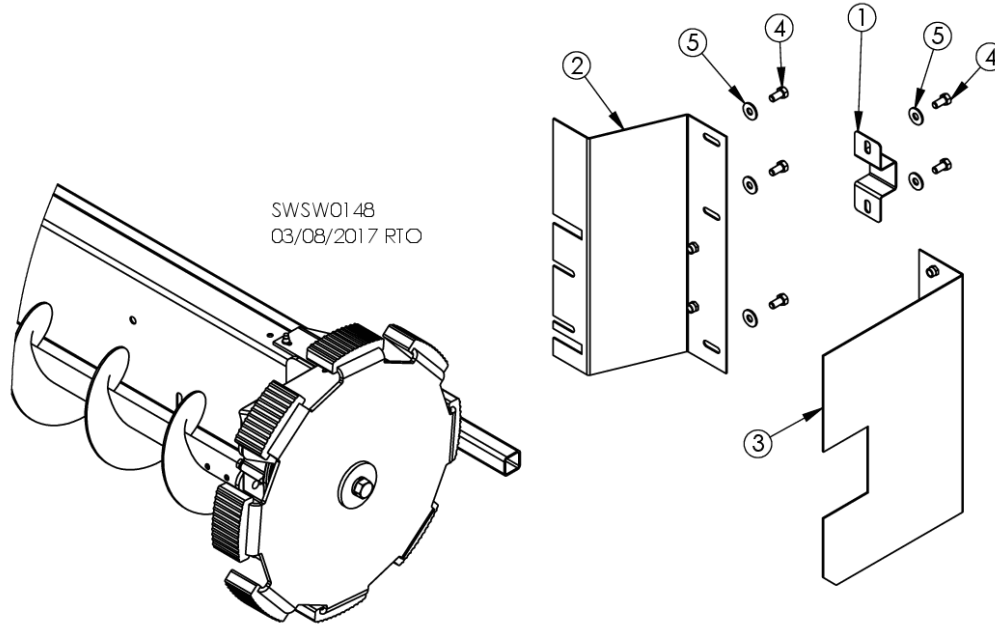

ITEM #	DESCRIPTION	6" COMP. #	8" COMP. #	10" COMP. #	QTY.
1	Reclaim shield support bracket	NA	E7381	E7381	1
2	Reclaim shield	E7398	E7382	E7380	1
3	Reclaim shield extension plate	E7397	E7397	E7397	1
4	Screw, 3/8 – 16 x 3/4"	J0605	J0605	J0605	5
5	Flat washer, 3/8"	J1117	J1117	J1117	5

REAR CARRIER WHEEL ASSEMBLY, PARTS LIST

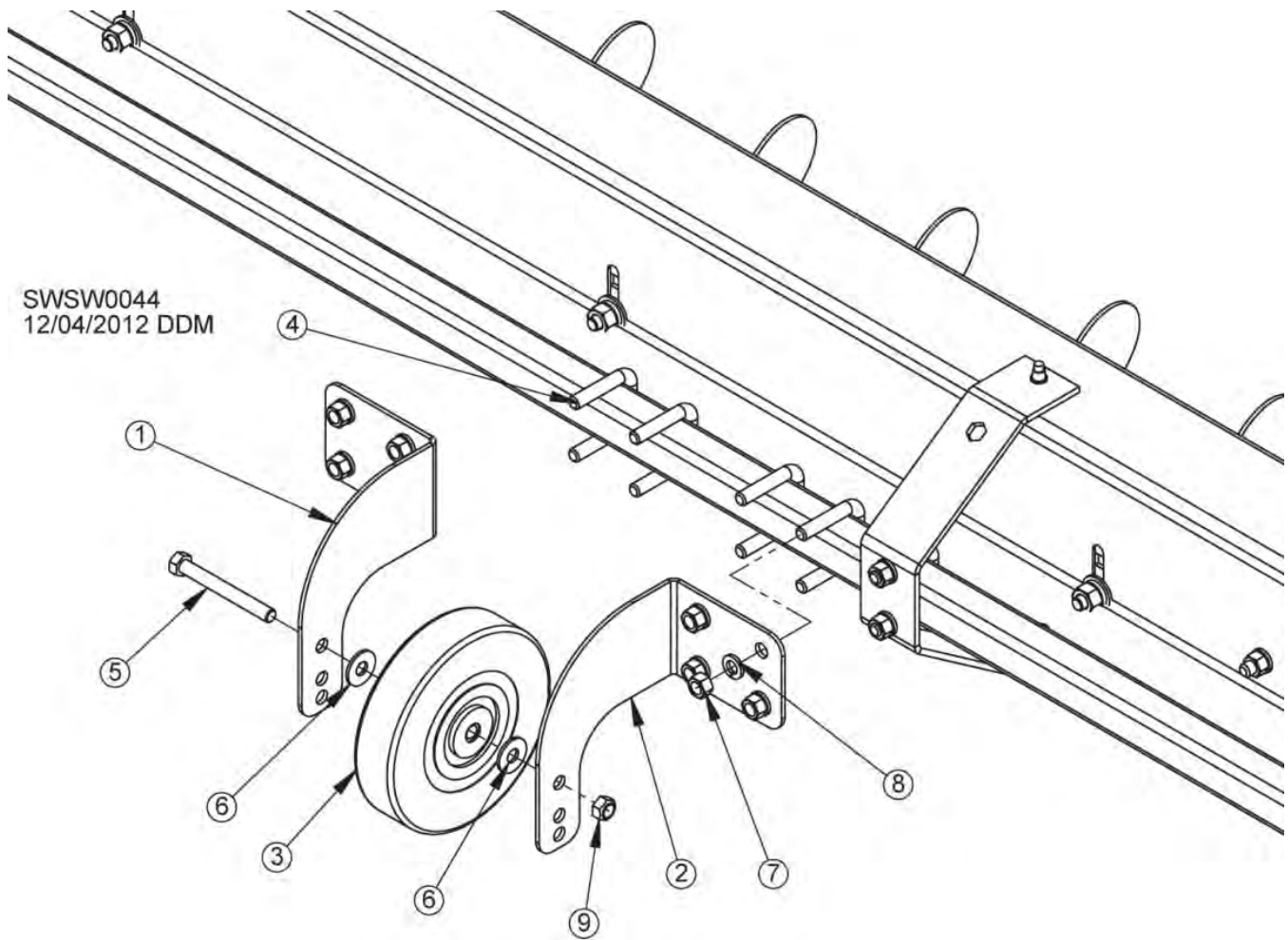

REF. #	DESCRIPTION	QTY.	COMP. #
	Rear carrier wheel kit	-	E6099
1	Left rear carrier wheel bracket	1	E7741
2	Right rear carrier wheel bracket	1	E7740
3	6" rubber wheel w/ bushing	1	J7271
4	Square U-bolt, 3/8" - 16	4	J0644
5	Bolt, 3/8 - 16 x 3-1/4", PLT	1	J0663
6	Flat washer, 3/8"	2	J1117
7	Hex nut, 3/8" -16, PLT	8	J1020
8	Split lock washer, 3/8", PLT	8	J1205
9	Lock nut, 3/8" - 16	1	J1025

SWEEP AUGER SUPPORT BUSHING ASSY.

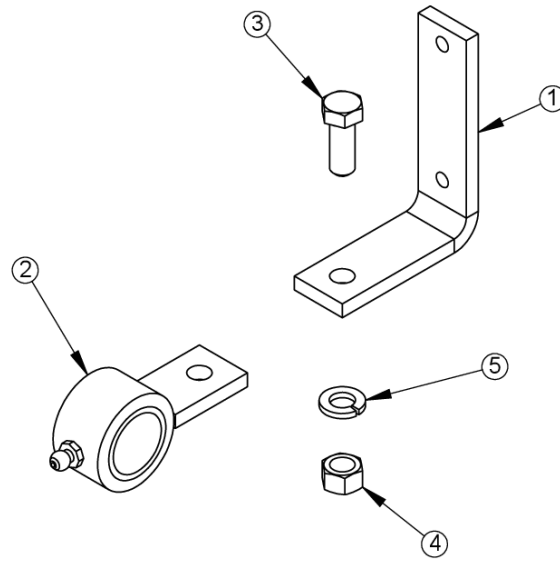

SWSW0203
05/31/2018 RTO

REF. #	DESCRIPTION	QTY.	6" COMP. #	8" COMP. #	10" COMP. #
	Complete assembly	1	E6089	E6090	E6091
1	Mounting bracket, 10"	1	E6061	E6063	E6064
2	Sweep auger bushing	1	E6065	E6065	E6065
3	Screw, 3/8 - 16 x 1"	1	J0606	J0606	J0606
4	Hex nut, 3/8" - 16	1	J1020	J1020	J1020
5	Lock washer, 3/8"	1	J1205	J1205	J1205

BIN COLLAR

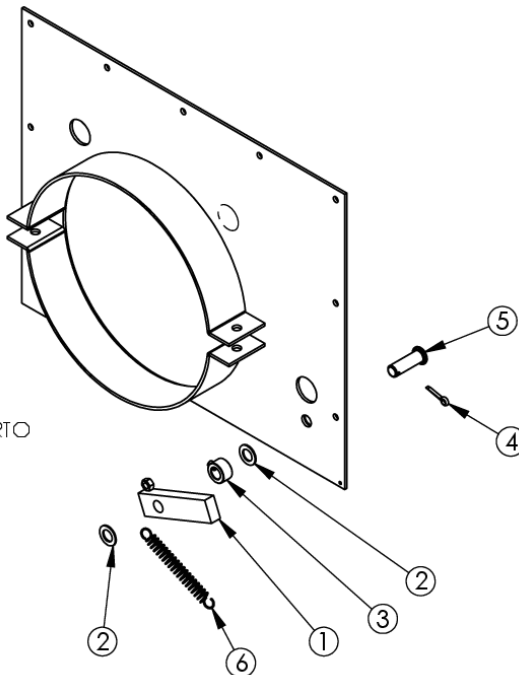

SWSW0204
06/06/2018 RTO

REF. #	DESCRIPTION	QTY.	COMP. #
1	Clutch latch	1	E5408
2	Machine bushing, 1/2" x 18ga	3	J1250
3	Shaft collar, 1/2"	1	J1320
4	Cotter pin, 1/8 x 1"	1	J1420
5	Picker pin, 1/2 x 1-1/2"	1	J1550
6	Pawl spring	1	J2360

QUICK REFERENCE PARTS LISTS

OPTIONAL - FARM-DUTY MOTORS (1750)

HP	PH	FRAME	SHAFT	LBS.	COMP. #
2	1	E182T	1-1/8"	67	H2175
	3	F145T	7/8"	50	H2475
3	1	J184T	1-1/8"	113	H2845
	3	E182T	1-1/8"	60	H3345
5	1	L184T	1-1/8"	122	H3675
	3	F184T	1-1/8"	72	H4190
7.5	1	K215T	1-3/8"	130	H4900
	3	213T	1-3/8"	84	H4910
10	1	215T	1-3/8"	143	H5300
	3	215T	1-3/8"	94	H5310
15	3	254T	1-5/8"	141	H6110
20	3	256T	1-5/8"	188	H6610

All motors are TEFC (Totally enclosed, fan cooled).

MOTOR PULLEYS

DIA.	BORE	GROOVE	SINGLE	DOUBLE	TRIPLE
3-1/2" OD	5/8"	B	J0309	---	---
	7/8"	B	J0310	J0315	---
	1-1/8"	B	J0312	J0317	---
	1-3/8"	B	J0313	J0318	J0331
3-3/4" OD	1-5/8"	B	---	J03211*	J0332*

*Requires split-taper bushing to obtain bore size. Order "SH" for 3-3/4".

SPLIT TAPER BUSHINGS

BUSHING	1-1/8" BORE	1-3/8" BORE	1-5/8" BORE	1-7/8" BORE
SD	J04191	J04264	J04263	J04284
SDS	J04194	J04241	---	---
SH	---	---	J04242	---

HORIZONTAL POWERHEAD SAFETY SHIELD KITS

UNLOAD TUBE DIA.	DESCRIPTION	COMP. #
6" & 8"	Std. enclosed shield, w/ brackets	E5982
10"	Std. enclosed shield, w/ brackets	E5983

REPLACEMENT VERTICAL FLIGHTING, SHAFTS & TUBES -- STANDARD BOTTOM DRIVE

NOTE: Vertical flight numbers include flipper and top and bottom shafts.

FLIGHTING FOR VERTICAL AUGER

DESCRIPTION	6" COMP. #	8" COMP. #	10" COMP. #
14' w/ dbl flight, 1"	E5806	-----	-----
14' w/ dbl flight, 1-1/4"	-----	E58071	E5783
16' w/ dbl flight, 1"	E5846	-----	-----
16' w/ dbl flight, 1-1/4"	-----	E5847	E57833
18' w/ dbl flight, 1"	E5848	-----	-----
18' w/ dbl flight, 1-1/4"	-----	E5849	E57832
20' w/ dbl flight, 1-1/4"	-----	E58541	E57834

VERTICAL TOP SHAFT

DESCRIPTION	6" COMP. #	8" COMP. #	10" COMP. #
1 x 12-1/8" w/ hole	E58091	-----	-----
1 x 10" w/ hole (Pre-1990)	E5809	E5809	-----
1 5/8 x 13-5/8" w/ hole (Pre-1990)	-----	-----	E58241
1-1/4 x 12-3/8" w/ hole	-----	E97711	-----
1 x 1-1/4 x 12-3/8" repl. w/ hole	-----	E9753	-----
2" x 15-5/8" w/ hole (1998)	-----	-----	E58243
Flipper	E5416	E5689	E5689

BOTTOM SHAFT

DESCRIPTION	6" COMP. #	8" COMP. #	10" COMP. #
1 x 10-7/8" w/ keyway	E58081	-----	-----
1 x 14-1/4" w/ keyway (Prior 1990)	E5808	E5808	
1-1/4 x 12-1/8" w/ keyway	-----	E9751	-----
1 x 1-1/4 x 10-1/8" repl. w/ keyway	-----	E9752	-----
2 x 1-1/4 x 13-7/8" w/ keyway (1998)	-----	-----	E58252

GALVANIZED TUBE

DESCRIPTION	6" COMP. #	8" COMP. #	10" COMP. #
10' long for 14' vertical auger	E5804	E5805	E57842
8' long for 14' vertical auger	-----	-----	E5784
12' long for 16' vertical auger	E5842	E5843	E57841
14' long for 18' vertical auger	E5844	E5845	E57843
16' long for 20' vertical auger	F4801	F4915	-----

UNLOAD AUGER FLIGHTING ASSEMBLY

6" SWEEPWAY

BIN DIAMETER	COMP. #
*15'-15' 6"	E6430
16' 5" (5M)	E64301
*18'-18' 7"	E6431
19' 8" (6M)	E64310
*21'-21' 8"	E6432
22' 11" (7M)	E64320
*24'-24' 9"	E6433
26' 3" (8M)	E64331
*27'-27' 10"	E6434
29' 6" (9M)	E64341
*30'-31'	E6435
*33'-34'	E6436
36' (11M)	E6417
37' 1"	E6437

* In larger bin dia. listed, use E5328 adapter to extend sweep.

8" SWEEPWAY

BIN DIA.	COMP. #	COMP. #
*15'-15' 6"	-	E6450
16' 5" (5M)	-	E6449
*18'-18' 7"	-	E6451
19' 8" (6M)	-	E64510
*21'-21' 8"	-	E6452
22' 11" (7M)	-	E64521
*24'-24' 9"	-	E6453
26' 3" (8M)	-	E64531
*27'-27' 10"	-	E6454
29' 6" (9M)	-	E64541
*30'-31'	-	E6455
*33'-34'	-	E6456
36' (11M)	-	E6457
37' 1"	-	E6457
42'	E6472	E64582
42' 8" (13M)	E6472	E64584
43' 3"	E6472	E64591
48'	E6472	E64602
49' 3" (15M)	E6472	E64611
54'	E6472	E64621
55' 8"	E6472	E64631
60'	E6472	E64641
61' 10"	E6472	E64651

* In larger bin dia. listed, use E5328 adapter to extend sweep.

10" SWEEPWAY

BIN DIA.	COMP. #	COMP. #
*21'-21' 8"	-	E6482
22' 11" (7M)	-	E64821
*24'-24' 9"	-	E6483
26' 3" (8M)	-	E64831
*27'-27' 10"	-	E6484
29' 6" (9M)	-	E64841
*30'-31'	-	E6485
*33'-34'	E6497	E64861
36' (11M)	E6497	E64871
37' 1"	E6497	E64871
42'	E6497	E64883
42' 8" (13M)	E6497	E64884
43' 3"	E6497	E64891
48'	E6497	E64901
49' 3" (15M)	E6497	E64911
54'	E6497	E64922
55' 8"	E6497	E64932
60'	E6497	E64941
61' 10"	E6497	E64951

* In larger bin dia. listed, use E5328 adapter to extend sweep.

SWEEP AUGER REPLACEMENT KITS

6" SWEEPWAY

BIN DIAMETER	COMP. #
15'-15' 6"	E82200
16' 5" (5M)	E82201
18'-18' 7"	E82202
19' 8" (6M)	E82203
21'-21' 8"	E82204
22' 11" (7M)	E82205
24'-24' 9"	E82206
26' 3" (8M)	E82207
27'-27' 10"	E82208
29' 6" (9M)	E82209
30'-31'	E82210
33'-34'	E82211
36' (11M)	E82212
37' 1"	E82213

8" SWEEPWAY

BIN DIAMETER	COMP. #
15'-15' 6"	E82214
16' 5" (5M)	E82215
18'-18' 7"	E82216
19' 8" (6M)	E82217
21'-21' 8"	E82218
22' 11" (7M)	E82219
24'-24' 9"	E82220
26' 3" (8M)	E82221
27'-27' 10"	E82222
29' 6" (9M)	E82223
30'-31'	E82224
33'-34'	E82225
36' (11M)	E82226
37' 1"	E82227
42'	E82228
42'8" (13M)	E82229
43'3"	E82230
48'	E82231
49'3" (15M)	E82232
54'	E82233
55'8" (17M)	E82234
60'	E82235
61'10"	E82236

10" SWEEPWAY

BIN DIAMETER	COMP. #
24'-24' 9"	E82237
26' 3" (8M)	E82238
27'-27' 10"	E82239
29' 6" (9M)	E82240
30'-31'	E82241
33'-34'	E82242
36' (11M)	E82243
37' 1"	E82244
42'	E82245
42'8"	E82246
43'3"	E82247
48'	E82248
49'3"	E82249
54'	E82250
55'8"	E82251
60'	E82252
61'10"	E82253

NOTES



Contact Information

CONTACT INFORMATION

Owner's manuals are available from Sukup and additional copies can be requested at the address, phone number or e-mail address shown below. Please indicate manual number L1435 when requesting Sweepway Owner's Installation & Operation Manual.

Sukup Dealer Information

Dealer name: _____
Address: _____
Cell phone: _____
Office phone: _____
Fax: _____

In Case of Emergency

Have emergency numbers and written directions to your location near a phone, and arrange and practice a safety plan.

Ambulance • Fire • Police: 9-1-1
Bin rescue team: _____
Local EMS team: _____
911 address of work site: _____
Directions to work site: _____

**Sukup Manufacturing Co.****1555 255th Street, Box 677****Sheffield, Iowa, USA 50475-0677****Phone: 641-892-4222****Fax: 641-892-4629****Website: www.sukup.com****Email: info@sukup.com**