

**MK AUGER
BOOT / HOPPER / LIFT CYLINDER**

Description	Page
MK100 x 36' basic auger	H2-3
MK80 - MK100 x 51' basic auger w/inset	H4-5
MK80 - MK100 x 61' basic auger w/inset	H6-7
MK80 - MK100 x 71' basic auger w/inset	H8-9
MK100 x 81' basic auger	H10-11
MK130 - MK130 ^{PLUS} x 61' basic auger	H12-13
MK130 - MK130 ^{PLUS} x 71' basic auger	H14-15
MK130 - MK130 ^{PLUS} x 81' basic auger	H16-17
MK100 - MK130 - MK130 ^{PLUS} x 91' - 111' basic tube	H18-19
MK100 - MK130 x 91' - 111' basic frame	H20-21
MK80 - MK100 - MK130 - MK130 ^{PLUS} swing hopper	H22
MK100 - MK130 low profile hopper	H23
MK80 - MK100 - MK130 - MK130 ^{PLUS} boot/hopper lift assembly	H24
Lift cylinders for 1990/1991 and later	H25
MK reverser	H26
MK Right Angle Drive	H27
MK Speed Reducer	H28

MKAUGER AUGER / BOOT / HOPPER	H
----------------------------------	---

MK100 - 36' Basic Auger

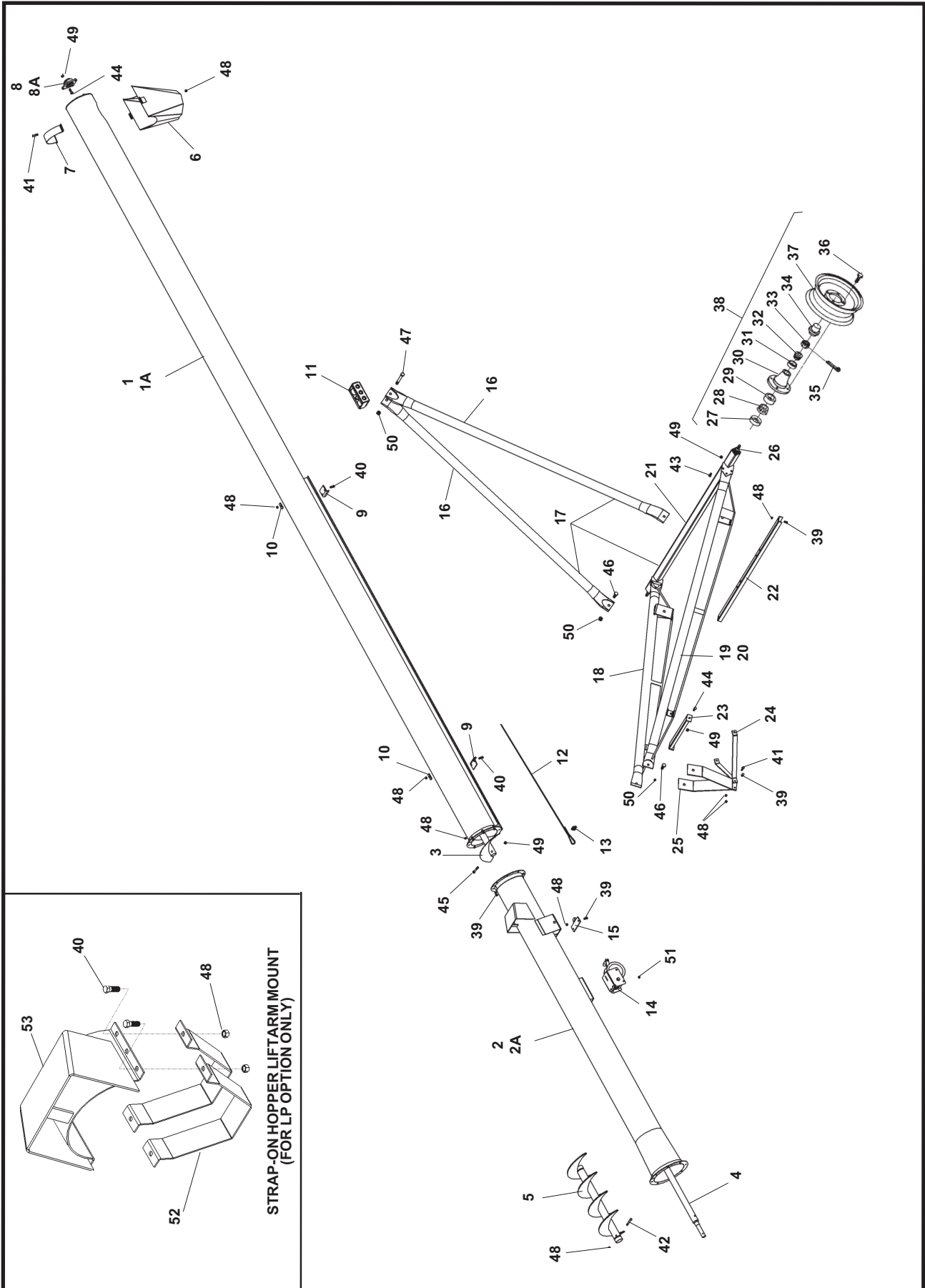

MK100 - 36' Basic Auger

REF. NO.	PART NO.	PARTS DESCRIPTION	REF. NO.	PART NO.	PARTS DESCRIPTION
1	18881	Upper tube section	46	19592	Bolt, 3/4" x 2", grade 5
1A	18883	Upper tube bundle, as shipped	47	19593	Bolt, 3/4" x 6-1/2", grade 5
2	28275	Lower tube section	48	19598	Locknut, 7/16"
2A	28274	Lower tube bundle, as shipped	49	19599	Locknut, 1/2"
3	18889	Upper flight section	50	19601	Locknut, 3/4"
4	18911	Lower flight section	51	19596	Whiznut, 3/8"
5	18921	Intake flight section			
6	18029	Spout, less halfband			
7	19801	Halfband			
8	19567	1-1/4" Bearing, 4-bolt			
8A	18852	1-1/4" Bearing, less flange			
9	18762	Track stop	52	17340	FORLPOPTION ONLY: WR100 over track clamp
10	17182	Track washer, 7/16"	53	17366	MK100 strap on lift mount
11	18763	Roller track shoe			
12	19248	1/4" Cable, 34'6" long			
13	19147	1/4" Cable clamp			
14	19152	Winch, K1500			
15	28283	Cable anchor return bracket			
16	28280	Upper lift tube, left or right			
17	28279	Upper lift bundle, as shipped			
18	28277	Lower reach tube, left			
19	28278	Lower reach tube, right			
20	28276	Lower reach frame bundle, as shipped			
21	18090	Axle, w/ spindle, nuts, cotter pin			
22	19376	Crossmember			
23	18914	Short crossmember			
24	18908	Stabilizer brace			
25	18909	Stabilizer bracket			
26	19263	Weld on spindle			
27	19264	Seal			
28	19265	Large bearing, Timken #LM 67048			
29	19266	Large cup, Timken #LM 67010			
30	19267	Hub w/cups			
31	19268	Small cup, Timken #LM 11910			
32	19269	Small bearing, Timken #LM 11949			
33	19270	Slotted nut, 3/4-16			
34	19272	Dust cap			
35	19271	Cotter pin, 1/8 x 1-1/2"			
36	19273	Wheel bolt, 1/2-20 x 1"			
37	19261	Wheel, 15", 4 bolt			
38	19467	Hub assembly, complete			
39	19542	Bolt, 7/16" x 1", grade 5			
40	18698	Bolt, 7/16" x 1-1/4", grade 5			
41	19981	Bolt, 7/16" x 1-3/4", grade 5			
42	19547	Bolt, 7/16" x 3-1/2", grade 5			
43	19588	Bolt, 1/2" x 1-1/4", grade 5			
44	19589	Bolt, 1/2" x 1-1/2", grade 2			
45	19798	Bolt, 1/2" x 2-3/4", grade 8			

MK80 / MK100 - 51 Basic Auger

NOTE: Lift system for 1990 models shown in inset

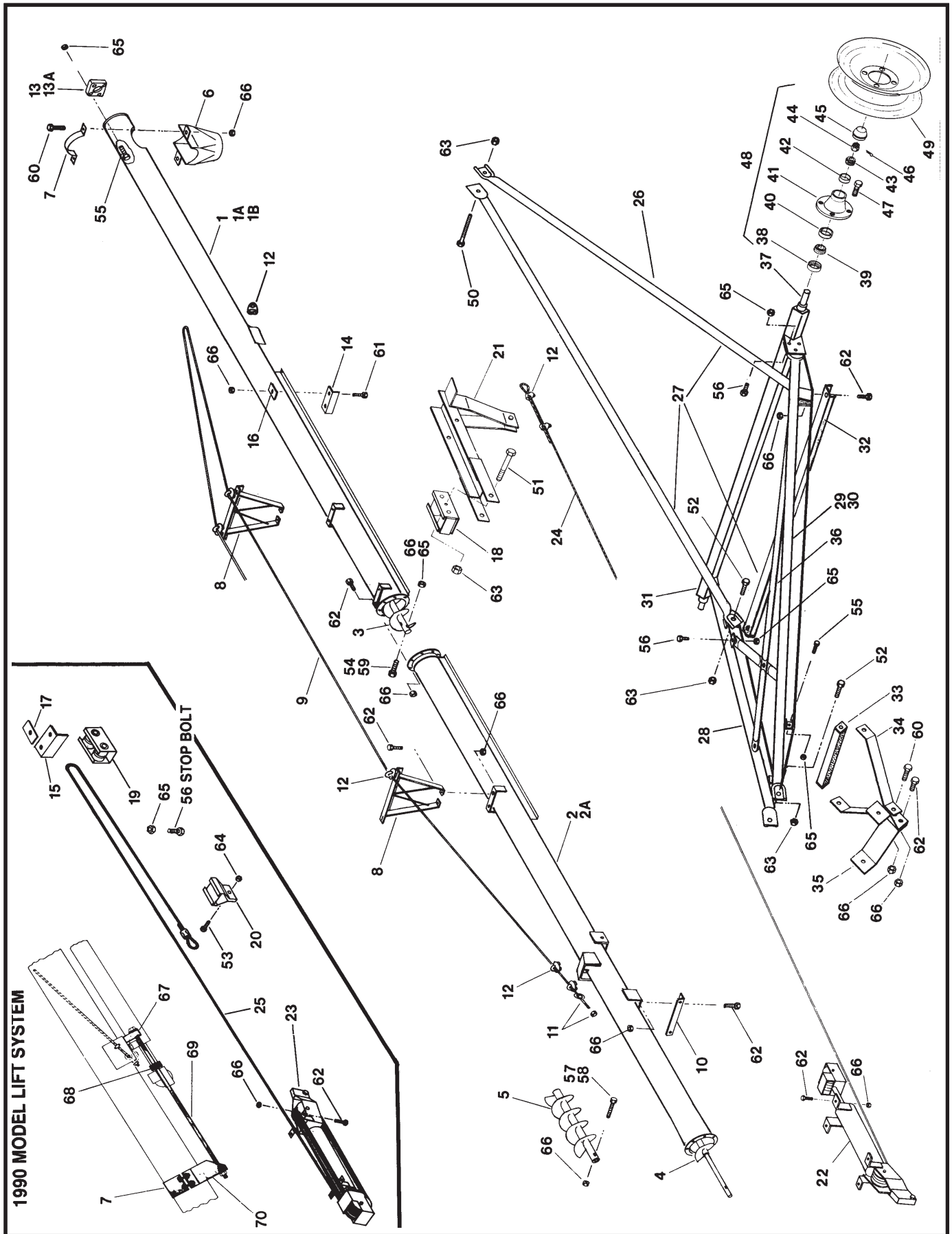

MK80 / MK100 - 51' Basic Auger

REF. NO.	PART NO.		PART DESCRIPTION
	MK80	MK100	
1	18880	18881	Upper tube section
1A	18882	18883	Upper tube bundle, as shipped
1B	18892	18893	* 1990 Upper tube section
2	18884	18885	Lower tube section
2A	18886	18887	Lower tube bundle, as shipped
3	18888	18889	Upper flight section
4	18890	18891	Lower flight section
5	18920	18921	Boot flight section
6	18028	18029	Spout, less halfband
7	19460	19801	Halfband
8	19324	19324	Truss support bracket, low
9	18826	18826	Truss cable
10	18031	18032	Truss attach angle
11	19331	19331	Eyebolt w/nut
12	19333	19333	5/16" cable clamp
13	19567	19567	1-1/4" Bearing, 4 bolt
13A	18852	18852	1-1/4" Bearing, less flange
14	18745	18745	Track stop
15	18795	18795	* 1990 Track stop
16	18917	18917	Track stop washer
17	18929	18929	* 1990 Track stop washer
18	18922	18922	Track shoe
19	18919	18919	* 1990 Track shoe
20	18918	18918	* 1990 Slider track shoe
21	18930	18930	Lift assist bracket
22	18033	18033	Hydraulic cylinder w/pulleys & cable
23	18764	18764	* 1990 Hydraulic cylinder w/pulleys & cable
24	18042	18042	5/16" Lift cable
25	18189	18189	* 1990 5/16" Lift cable
26	19792	19792	Upper lift tube, left or right
27	19793	19793	Upper lift bundle, as shipped
28	19789	19789	Lower reach tube, left
29	19790	19790	Lower reach tube, right
30	19791	19791	Lower reach frame bundle, as shipped
31	18090	18090	Axle w/spindle, nuts, cotter pin
32	19376	19376	Cross member
33	18914	18914	Short cross member
34	18908	18908	Stabilizer brace
35	18909	18909	Stabilizer bracket
36	19796	19796	Cross brace
37	19263	19263	Weld on spindle
38	19264	19264	Seal
39	19265	19265	Large bearing, Timken no. LM67048
40	19266	19266	Large cup, Timken no. LM67010
41	19267	19267	Hub w/cups
42	19268	19268	Small cup, Timken no. LM11910

REF. NO.	PART NO.		PART DESCRIPTION
	MK80	MK100	
43	19269	19269	Small bearing, Timken no. LM11949
44	19270	19270	Slotted nut, 3/4" - 16
45	19272	19272	Dust cap
46	19271	19271	Cotter pin, 1/8" x 1-1/2"
47	19273	19273	Wheel bolt, 1/2" - 20 x 1-1/4"
48	19467	19467	Hub assembly, complete
49	19261	19261	15" Wheel, 4 bolt
50	18094	18094	Bolt, 3/4" - 10 x 7-1/2", grade 5
51	19593	19593	Bolt, 3/4" - 10 x 6-1/2", grade 5
52	19592	19592	Bolt, 3/4" - 10 x 2", grade 5
53	19991	19991	Bolt, 5/8" - 11 x 2", grade 5
54	—	19798	Bolt, 1/2" - 13 x 2-3/4", grade 8
55	19589	19589	Bolt, 1/2" - 13 x 1-1/2", grade 2
56	19588	19588	Bolt, 1/2" - 13 x 1-1/4", grade 5
57	—	19547	Bolt, 7/16" - 14 x 3-1/2", grade 5
58	19546	—	Bolt, 7/16" - 14 x 3", grade 5
59	19545	—	Bolt, 7/16" - 14 x 2-1/4", grade 8
60	19981	19981	Bolt, 7/16" - 14 x 1-3/4", grade 5
61	18698	18698	Bolt, 7/16" - 14 x 1-1/4", grade 5
62	19542	19542	Bolt, 7/16" - 14 x 1", grade 5
63	19601	19601	Locknut, 3/4" - 10
64	19600	19600	Locknut, 5/8" - 11
65	19599	19599	Locknut, 1/2" - 13
66	19598	19598	Locknut, 7/16" - 14
67	18925	18925	* 1990 Upper rod guide bracket
68	18927	18927	* 1990 Ram guide clamp
69	18928	18928	* 1990 Guide rod
70	18926	18846	* 1990 Lower rod guide bracket
71	17040	17041	* 1990 Rod guide half clamp

* NOTE: SOME OF THE LIFT SYSTEM AND TUBE SECTION PARTS ARE DIFFERENT FOR THE 1990 MODEL MK AUGERS. THESE PARTS ARE IDENTIFIED WITH AN ASTERISK *

MK80 / MK100 - 61 Basic Auger

NOTE: Lift system for 1990 models shown in inset

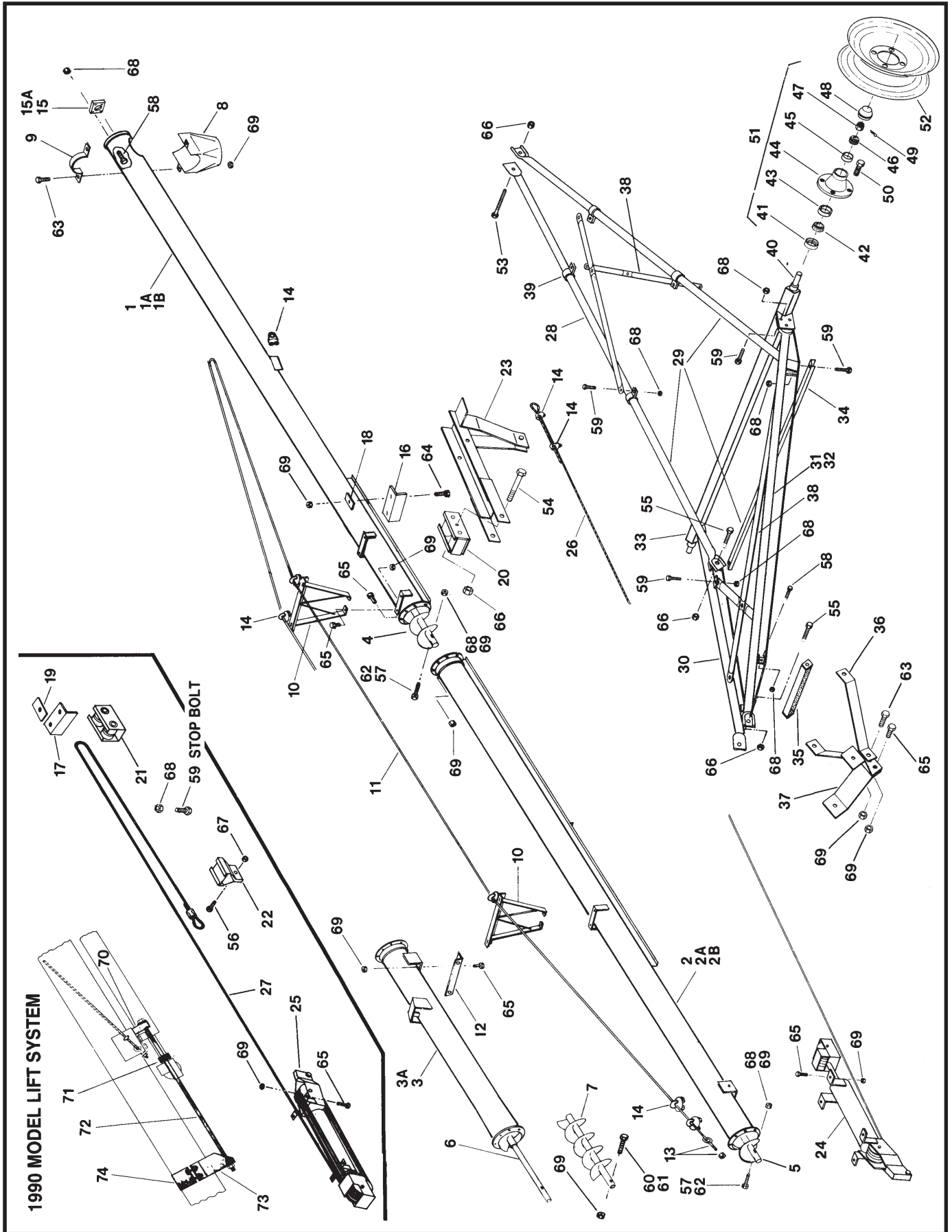

MK80 / MK100 - 61' Basic Auger

REF. NO.	PART NO.		PART DESCRIPTION
	MK80	MK100	
41	19264	19264	Seal
42	19265	19265	Large bearing, Timken no. LM67048
43	19266	19266	Large cup, Timken no. LM67010
44	19267	19267	Hub w/cups
45	19268	19268	Small cup, Timken no. LM11910
46	19269	19269	Small bearing, Timken no. LM11949
47	19270	19270	Slotted nut, 3/4" - 16
48	19272	19272	Dust cap
49	19271	19271	Cotter pin, 1/8" x 1-1/2"
50	19273	19273	Wheel bolt, 1/2" - 20 x 1-1/4"
51	19467	19467	Hub assembly, complete
52	19261	19261	15" wheel, 4 bolt
53	18094	18094	Bolt, 3/4" - 10 x 7-1/2", grade 5
54	19593	19593	Bolt, 3/4" - 10 x 6-1/2", grade 5
55	19592	19592	Bolt, 3/4" - 10 x 2", grade 5
56	19991	19991	Bolt, 5/8" - 11 x 2", grade 5
57	—	19798	Bolt, 1/2" - 13 x 2-3/4", grade 8
58	19589	19589	Bolt, 1/2" - 13 x 1-1/2", grade 2
59	19588	19588	Bolt, 1/2" - 13 x 1-1/4", grade 5
60	—	19547	Bolt, 7/16" - 14 x 3-1/2", grade 5
61	19546	—	Bolt, 7/16" - 14 x 3", grade 5
62	19545	—	Bolt, 7/16" - 14 x 2-1/4", grade 8
63	19981	19981	Bolt, 7/16" - 14 x 1-3/4", grade 5
64	18698	18698	Bolt, 7/16" - 14 x 1-1/4", grade 5
65	19542	19542	Bolt, 7/16" - 14 x 1", grade 5
66	19601	19601	Locknut, 3/4" - 10
67	19600	19600	Locknut, 5/8" - 11
68	19599	19599	Locknut, 1/2" - 13
69	19598	19598	Locknut, 7/16" - 14
70	18925	18925	* 1990 Upper rod guide bracket
71	18927	18927	* 1990 Ram guide clamp
72	18928	18928	* 1990 Guide rod
73	18926	18846	* 1990 Lower rod guide bracket
74	17040	17041	* 1990 Rod guide half clamp

* NOTE: SOME OF THE LIFT SYSTEM AND TUBE SECTION PARTS ARE DIFFERENT FOR THE 1990 MODEL MK AUGERS. THESE PARTS ARE IDENTIFIED WITH AN ASTERISK *

REF. NO.	PART NO.		PART DESCRIPTION
	MK80	MK100	
1	18880	18881	Upper tube section
1A	18882	18883	Upper tube bundle, as shipped
1B	18892	18893	* 1990 Upper tube section
2	18896	18897	Middle tube section
2A	18898	18899	Middle tube bundle, as shipped
2B	18894	18895	* 1990 Middle tube section
3	18900	18901	Lower tube section
3A	18902	18903	Lower tube bundle, as shipped
4	18888	18889	Upper flight section
5	19552	19757	Middle flight section
6	18910	18911	Lower flight section
7	18920	18921	Boot flight section
8	18028	18029	Spout less halfband
9	19460	19801	Halfband
10	19324	19324	Truss support bracket, low
11	18854	18854	Truss cable
12	18031	18032	Truss attach angle
13	19331	19331	Eye bolt w/nut
14	19333	19333	5/16" Cable clamp
15	19567	19567	1-1/4" Bearing, 4 bolt
15A	18852	18852	1-1/4" Bearing, less flange
16	18745	18745	Track stop
17	18795	18795	* 1990 Track stop
18	18917	18917	Track stop washer
19	18929	18929	* 1990 Track stop washer
20	18922	18922	Track shoe
21	18919	18919	* 1990 Track shoe
22	18918	18918	* 1990 Slider track shoe
23	18930	18930	Lift assist bracket
24	18034	18034	Hydraulic cylinder w/pulleys & cable
25	18760	18760	* 1990 Hydraulic cylinder w/pulleys & cable
26	18043	18043	5/16" Lift cable
27	18923	18923	* 1990 5/16" Lift cable
28	19524	19524	Upper lift tube, left or right
29	19534	19534	Upper lift bundle, as shipped
30	19358	19358	Lower reach tube, left
31	19359	19359	Lower reach tube, right
32	19369	19369	Lower reach frame bundle, as shipped
33	19342	19342	Axle w/spindle, nuts, cotter pin
34	19378	19378	Cross member
35	18914	18914	Short cross member
36	18916	18916	Stabilizer brace
37	18909	18909	Stabilizer bracket
38	19796	19796	Cross brace
39	19797	19797	Cross brace clamp
40	19263	19263	Weld on spindle

MK80 / MK100 - 71 Basic Auger

NOTE: Lift system for 1990 models shown in inset

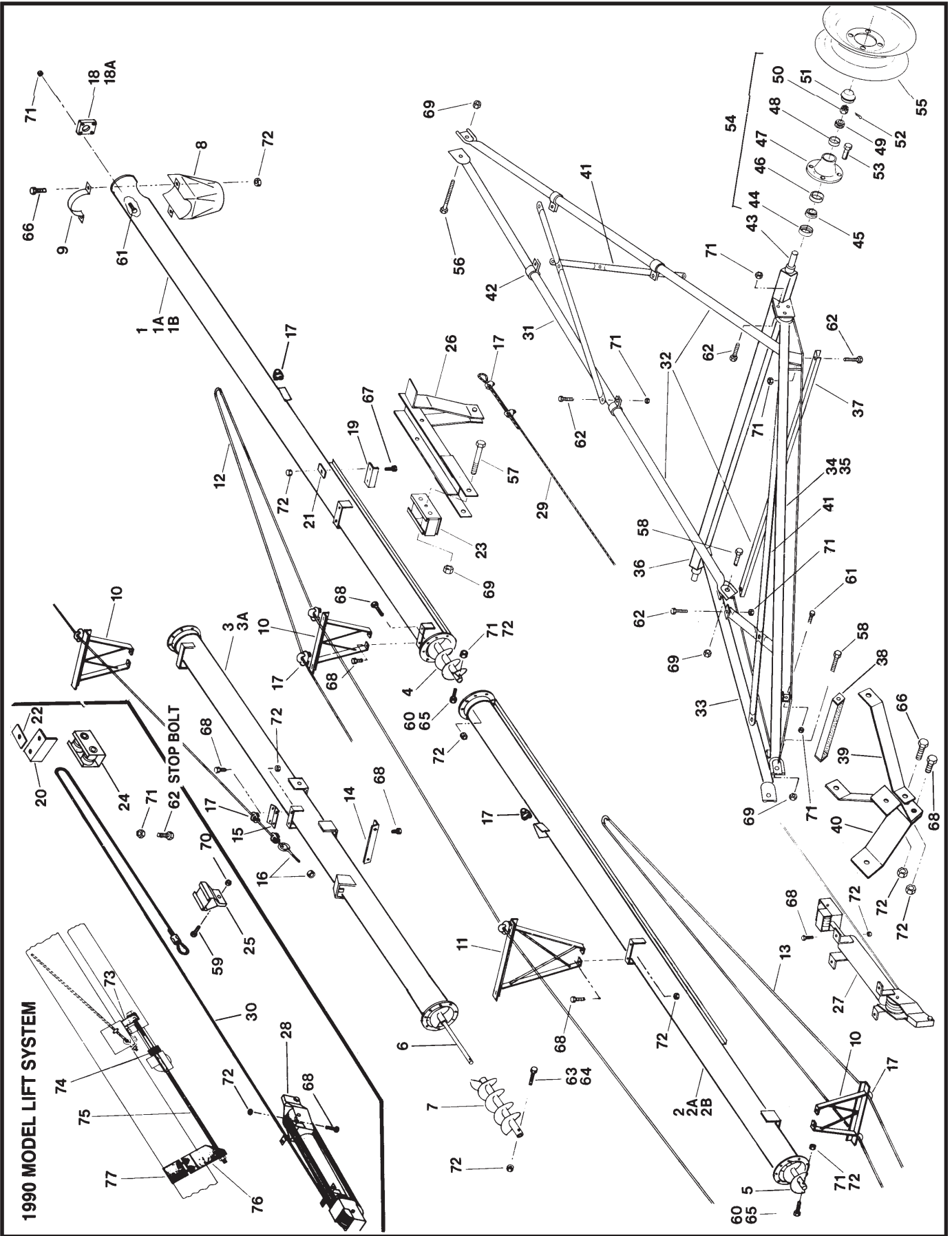

MK80 / MK100 - 71' Basic Auger

REF. NO.	PART NO.		PART DESCRIPTION
	MK80	MK100	
1	18880	18881	Upper tube section
1A	18882	18883	Upper tube bundle, as shipped
1B	18892	18893	* 1990 Upper tube section
2	18896	18897	Middle tube section
2A	18898	18899	Middle tube bundle, as shipped
2B	18894	18895	* 1990 Middle tube section
3	18904	18905	Lower tube section
3A	18906	18907	Lower tube bundle, as shipped
4	18888	18889	Upper flight section
5	19552	19757	Middle flight section
6	18912	18913	Lower flight section
7	18920	18921	Boot flight section
8	18028	18029	Spout less halfband
9	19460	19801	Halfband
10	19324	19324	Truss support bracket, low
11	19325	19325	Truss support bracket, high
12	18855	18855	Truss cable, upper
13	17042	17042	Truss cable, lower
14	18031	18032	Truss attach angle, lower
15	19332	19332	Truss attach angle, upper
16	19331	19331	Eye bolt w/nut
17	19333	19333	5/16" cable clamp
18	19567	19567	1-1/4" Bearing, 4 bolt
18A	18852	18852	1-1/4" Bearing, less flange
19	18745	18745	Track stop
20	18795	18795	* 1990 Trackstop
21	18917	18917	Track stop washer
22	18929	18929	* 1990 Track stop washer
23	18922	18922	Track shoe
24	18919	18919	* 1990 Track shoe
25	18918	18918	* 1990 Slider track shoe
26	18930	18930	Lift assist bracket
27	18035	18035	Hydraulic cylinder w/pulleys & cable
28	18761	18761	* 1990 Hydraulic cylinder w/pulleys & cable
29	18044	18044	5/16" Lift cable
30	18924	18924	* 1990 5/16" Lift cable
31	19525	19525	Upper lift tube, left or right
32	19535	19535	Upper lift bundle, as shipped
33	19360	19360	Lower reach tube, left
34	19361	19361	Lower reach tube, right
35	19370	19370	Lower reach frame bundle, as shipped
36	19343	19343	Axle w/spindle, nuts, coffer pin
37	19379	19379	Cross member
38	18914	18914	Short cross member
39	18915	18915	Stabilizer brace
40	18909	18909	Stabilizer bracket

REF. NO.	PART NO.		PART DESCRIPTION
	MK80	MK100	
41	19796	19796	Cross brace
42	19797	19797	Cross brace clamp
43	19263	19263	Weld on spindle
44	19264	19264	Seal
45	19265	19265	Large bearing, Timken no. LM67048
46	19266	19266	Large cup, Timken no. LM67010
47	19267	19267	Hub w/cups
48	19268	19268	Small cup, Timken no. LM11910
49	19269	19269	Small bearing, Timken no. LM11949
50	19270	19270	Slotted nut, 3/4" - 16
51	19272	19272	Dust cap
52	19271	19271	Cotter pin, 1/8" x 1-1/2"
53	19273	19273	Wheel bolt, 1/2" - 20 x 1-1/4"
54	19467	19467	Hub assembly, complete
55	19261	19261	15" Wheel, 4 bolt
56	18094	18094	Bolt, 3/4" - 10 x 7-1/2", grade 5
57	19593	19593	Bolt, 3/4" - 10 x 6-1/2", grade 5
58	19592	19592	Bolt, 3/4" - 10 x 2", grade 5
59	19991	19991	Bolt, 5/8" - 11 x 2", grade 5
60	—	19798	Bolt, 1/2" - 13 x 2-3/4", grade 8
61	19589	19589	Bolt, 1/2" - 13 x 1-1/2", grade 2
62	19588	19588	Bolt, 1/2" - 13 x 1-1/4", grade 5
63	—	19547	Bolt, 7/16" - 14 x 3-1/2", grade 5
64	19546	—	Bolt, 7/16" - 14 x 3", grade 5
65	19545	—	Bolt, 7/16" - 14 x 2-1/4", grade 8
66	19981	19981	Bolt, 7/16" - 14 x 1-3/4", grade 5
67	18698	18698	Bolt, 7/16" - 14 x 1-1/4", grade 5
68	19542	19542	Bolt, 7/16" - 14 x 1", grade 5
69	19601	19601	Locknut, 3/4" - 10
70	19600	19600	Locknut, 5/8" - 11
71	19599	19599	Locknut, 1/2" - 13
72	19598	19598	Locknut, 7/16" - 14
73	18925	18925	* 1990 Upper rod guide bracket
74	18927	18927	* 1990 Ram guide clamp
75	18928	18928	* 1990 Guide rod
76	18926	18846	* 1990 Lower rod guide bracket
77	17040	17041	* 1990 Rod guide half clamp

* NOTE: SOME OF THE LIFT SYSTEM AND TUBE SECTION PARTS ARE DIFFERENT FOR THE 1990 MODEL MK AUGERS. THESE PARTS ARE IDENTIFIED WITH AN ASTERISK *.

MK100 - 81' Basic Auger

REF. NO.	PART NO.	PART DESCRIPTION
1	27495	Upper tube section
1A	27510	Upper tube bundle, as shipped
2	27496	Upper middle tube section
2A	27511	Upper middle tube bundle, as shipped
3	27497	Lower middle tube section
3A	27512	Lower middle tube bundle, as shipped
4	27498	Lower tube section
4A	27513	Lower tube bundle, as shipped
5	17587	Upper flight section
6	17588	Middle flight section
7	18913	Lower flight section
8	18921	Boot flight section
9	18029	Spout less halfband
10	19801	Halfband
11	19324	Truss support bracket, low
12	19325	Truss support bracket, high
13	27501	Truss cable, upper
14	27502	Truss cable, lower
15	18032	Truss attach angle, lower
16	19332	Truss attach angle, upper
17	19331	Eye bolt w/nut
18	18990	3/8" cable clamp
19	19567	1-1/4" Bearing, 4 bolt
19A	18852	1-1/4" Bearing, less flange
20	18745	Track stop
21	18917	Track stop washer
22	27522	Lift arm extension bracket
23	27488	Lift arm extension
24	18922	Track shoe
25	27486	Ram guide
26	27487	Angle ring support
27	18930	Lift assist bracket
28	27506	Hydraulic cylinder w/pulleys & cable
28A	27505	Hydraulic cylinder only
29	27503	3/8" Lift cable
30	27499	Upper lift tube, left or right
31	27515	Upper lift bundle, as shipped
32	27492	Lower reach tube, left
33	27491	Lower reach tube, right
34	27514	Lower reach frame bundle, as shipped
35	27489	Axle base
35A	27523	Axle bundle, as shipped, including ref #40
36	27490	Axle extension
36A	27533	Weld-on spindle
37	27493	Short cross member
38	27504	Stabilizer brace

REF. NO.	PART NO.	PART DESCRIPTION
39	27494	Stabilizer bracket
40	27500	Cross brace
41	27507	Bushing, lower reach arm
42	27508	Bushing, top/bottom upper arms
43	17463	Corner brace
44	17006	Seal
45	17007	Large bearing, Timken no. LM29749
46	17008	Large cup, Timken no. LM29710
47	17009	Hub w/cups
48	19266	Small cup, Timken no. LM67010
49	19265	Small bearing, Timken no. LM67048
50	17010	Washer
51	17011	Slotted nut, 1"
52	17012	Dust cap
53	19271	Cotter pin
54	19273	Wheel bolt, 1/2" - 20 x 1-1/4"
55	17013	Hub assembly, complete
56	17014	15" Wheel, 6 bolt
57	19979	Washer, 3/4"
58	27482	Bolt, 3/4" - 10 x 8-1/2", grade 8
59	27483	Bolt, 3/4" - 10 x 7-1/2", grade 8
60	19592	Bolt, 3/4" - 10 x 2", grade 5
61	19991	Bolt, 5/8" - 11 x 2", grade 5
62	19798	Bolt, 1/2" - 13 x 2-3/4", grade 8
63	19589	Bolt, 1/2" - 13 x 1-1/2", grade 2
64	19588	Bolt, 1/2" - 13 x 1-1/4", grade 5
65	19547	Bolt, 7/16" - 14 x 3-1/2", grade 5
66	19981	Bolt, 7/16" - 14 x 1-3/4", grade 5
67	18698	Bolt, 7/16" - 14 x 1-1/4", grade 5
68	19542	Bolt, 7/16" - 14 x 1", grade 5
69	19601	Locknut, 3/4" - 10
70	19600	Locknut, 5/8" - 11
71	19599	Locknut, 1/2" - 13
72	19598	Locknut, 7/16" - 14
73	19648	Saddle pin
74	18079	Roll pin, 5/16" x 2"
75	19333	5/16" Cable clamp

MK130/ MK130^{PLUS} - 61 Basic Auger

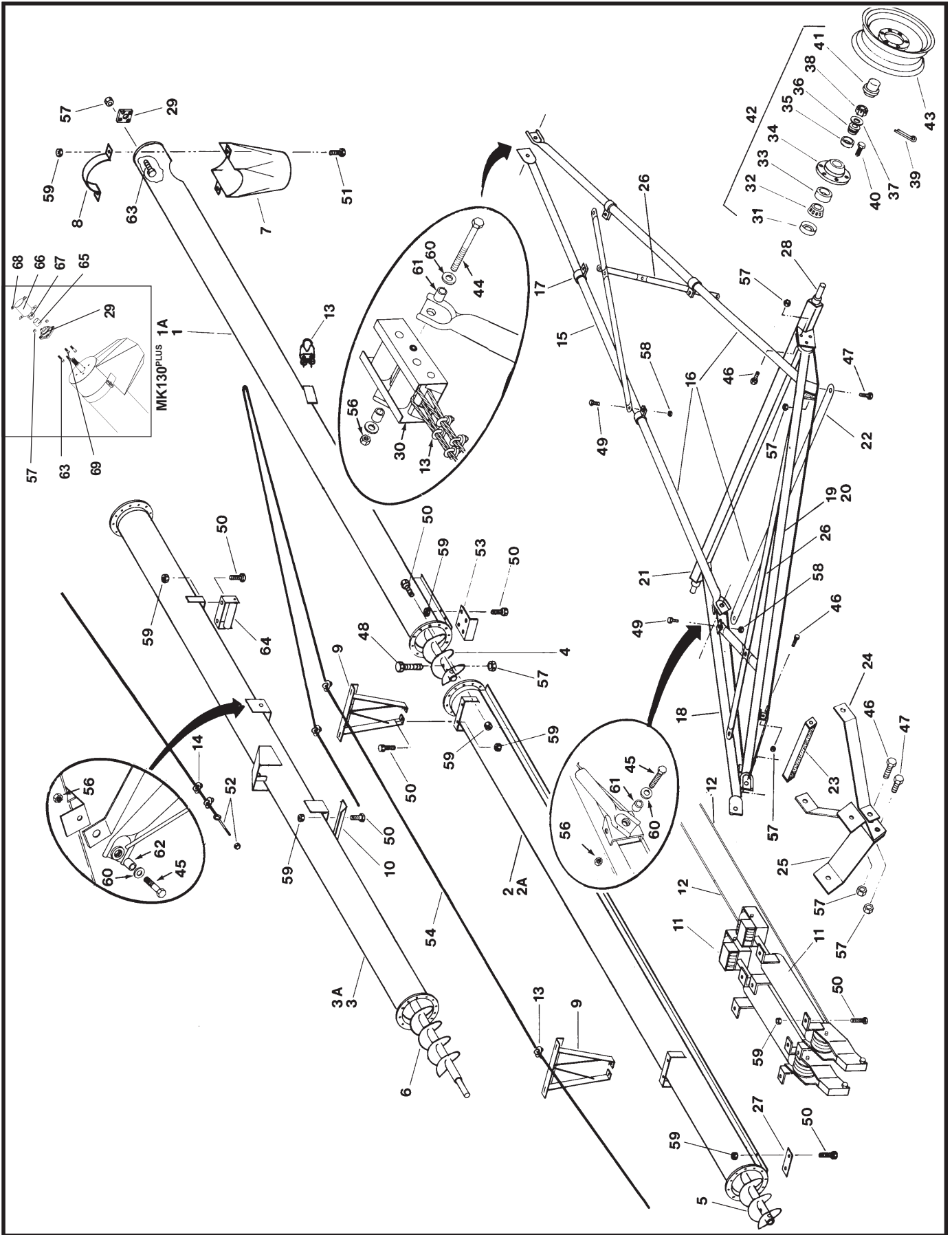

MK130 /MK130^{PLUS} - 61' Basic Auger

REF. NO.	PART NO.		PART DESCRIPTION
	MK130-61	MK130 ^{PLUS} -61	
44	17015	17015	Bolt, 1" - 8 x 10", grade 8
45	17016	17016	Bolt, 1" - 8 x 3-1/2", grade 8
46	19991	19991	Bolt, 5/8" - 11 x 2", grade 5
47	19590	19590	Bolt, 5/8" - 11 x 1-1/2", grade 5
48	18545	18545	Bolt, 5/8" - 11 x 4-1/2", grade 8
49	19588	19588	Bolt, 1/2" - 13 x 1-1/4", grade 5
50	18698	18698	Bolt, 7/16" - 14 x 1-1/4", grade 5
51	19981	19981	Bolt, 7/16" - 14 x 1-3/4", grade 5
52	19331	19331	Eyebolt, 1/2" - 13 x 5" w/locknut
53	17017	17017	Trackstop
54	17018	17018	Truss cable
56	17019	17019	Locknut, 1" - 8
57	19600	19600	Locknut, 5/8" - 11
58	19599	19599	Locknut, 1/2" - 13
59	19598	19598	Locknut, 7/16" - 14
60	17020	17020	Flatwasher, 1"
61	17021	17021	Short spacer bushing
62	17022	17022	Long spacer bushing
63	18544	18544	Bolt, 5/8" - 11 x 1-3/4", grade 5
64	17024	17024	Cable roller
65	---	27575	Bushing, Thrust adjuster
66	---	27576	Thrust adjuster cover
67	---	27587	NF hex nut, 1-1/2"
68	---	27588	5/8" washer locknut
69	---	27589	Bolt, 5/8" - 11 x 2-1/2", grade 5

REF. NO.	PART NO.		PART DESCRIPTION
	MK130-61	MK130 ^{PLUS} -61	
1	18977	18977	Upper tube section
1A	18978	18978	Upper tube bundle, as shipped
2	18979	18979	Middle tube section
2A	18980	18980	Middle tube bundle, as shipped
3	18981	18981	Lower tube section
3A	18982	18982	Lower tube bundle, as shipped
4	18983	27591	Upper flight section
5	18984	18984	Middle flight section
6	18985	18985	Lower flight section
7	18986	18986	Spout, less halfband
8	18987	18987	Tube halfband
9	18988	18988	Truss support bracket, low
10	18989	18989	Truss attach angle
11	18034	18034	Hydraulic cylinder, w/pulleys & cable
12	18043	18043	5/16" Lift cable
13	19333	19333	5/16" Cable clamp
14	18990	18990	3/8" Cable clamp
15	18991	18991	Upper lift tube, left or right
16	18992	18992	Upper lift bundle, as shipped
17	18993	18993	Brace clamp
18	18994	18994	Lower reach tube, left
19	18995	18995	Lower reach tube, right
20	18996	18996	Lower reach frame bundle, as shipped
21	18997	18997	Axle w/spindle, nuts, cotter pin
22	18998	18998	Cross member
23	18999	18999	Short cross member
24	17000	17000	Stabilizer brace
25	27546	27546	Stabilizer bracket
26	17002	17002	Cross brace
27	17003	17003	Lower track stop
28	17004	17004	Weild on spindle
29	18518	18518	1-3/4" bearing, 4 bolt
30	17005	17005	Track shoe
31	17006	17006	Seal
32	17007	17007	Large bearing, Timken no. LM29749
33	17008	17008	Large cup, Timken no. LM29710
34	17009	17009	Hub w/cups
35	19266	19266	Small cup, Timken no. LM67010
36	19265	19265	Small bearing, Timken No. LM67048
37	17010	17010	Washer
38	17011	17011	Slotted nut, 1"
39	19271	19271	Cotter pin, 1/8" x 1-1/2"
40	19273	19273	Wheel bolt, 1/2" - 20 x 1-1/4"
41	17012	17012	Dust cap
42	17013	17013	Hub assembly, complete
43	17014	17014	15" Wheel, 6 bolt

MK130 / MK130^{PLUS} - 71 Basic Auger

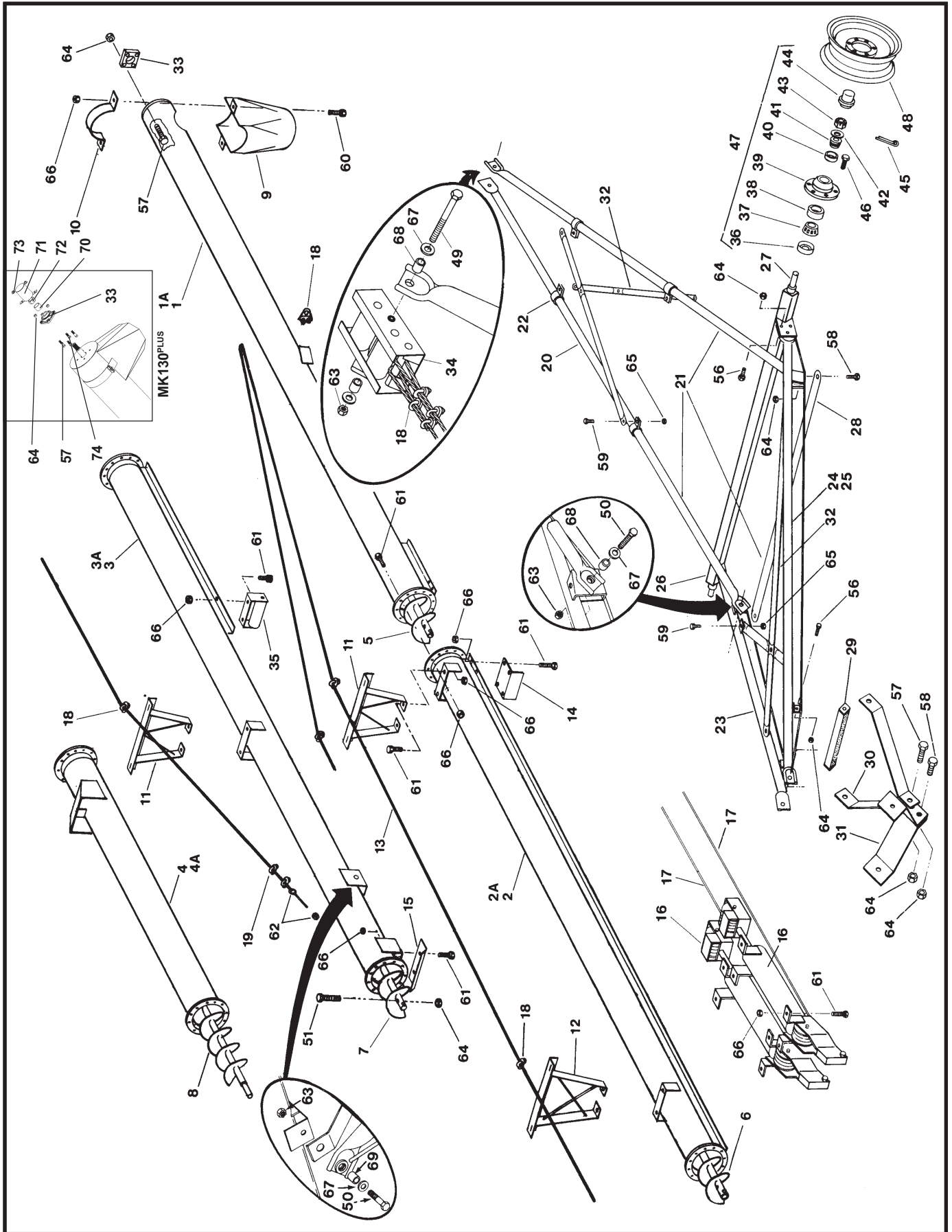

MK130 / MK130^{PLUS} - 71' Basic Auger

REF. NO.	PART NO.		PART DESCRIPTION
	MK130-71	MK130 ^{PLUS} -71	
43	17011	17011	Slotted nut, 1"
44	17012	17012	Dust cap
45	19271	19271	Cotter pin
46	19273	19273	Wheel bolt 1/2" - 20 x 1-1/4"
47	17013	17013	Hub assembly, complete
48	17014	17014	15" Wheel, 6 bolt
49	17015	17015	Bolt, 1" - 8 x 10", grade 8
50	17016	17016	Bolt, 1" - 8 x 3-1/2", grade 8
51	18545	18545	Bolt, 5/8" - 11 x 4-1/2", grade 8
56	19991	19991	Bolt, 5/8" - 11 x 2", grade 5
57	18544	18544	Bolt, 5/8" - 11 x 1-3/4", grade 5
58	19590	19590	Bolt, 5/8" - 11 x 1-1/2", grade 5
59	19588	19588	Bolt, 1/2" - 13 x 1-1/4", grade 5
60	19981	19981	Bolt, 7/16" - 14 x 1-3/4", grade 5
61	18698	18698	Bolt, 7/16" - 14 x 1-1/4", grade 5
62	19331	19331	Eye bolt, 1/2" - 13 x 5", w/locknut
63	17019	17019	Locknut, 1" - 8
64	19600	19600	Locknut, 5/8" - 11
65	19599	19599	Locknut, 1/2" - 13
66	19598	19598	Locknut, 7/16" - 14
67	17020	17020	Flatwasher, 1"
68	17021	17021	Short spacer bushing
69	17022	17022	Long spacer bushing
70	---	27575	Bushing, Thrust adjuster
71	---	27576	Thrust adjuster cover
72	---	27587	NF hex nut, 1-1/2"
73	---	27588	5/8" Washer locknut
74	---	27589	Bolt, 5/8" - 11 x 2-1/2", grade 5

REF. NO.	PART NO.		PART DESCRIPTION
	MK130-71	MK130 ^{PLUS} -71	
1	18977	18977	Upper tube section
1A	18978	18978	Upper tube bundle, as shipped
2	18979	18979	Middle tube section
2A	18980	18980	Middle tube bundle, as shipped
3	17025	17025	Lower middle tube section
3A	17026	17026	Lower middle tube bundle, as shipped
4	17027	17027	Lower tube section
4A	17028	17028	Lower tube bundle, as shipped
5	18983	27591	Upper flight section
6	18984	18984	Middle flight section
7	18984	18984	Middle flight section
8	17030	17030	Lower flight section
9	18986	18986	Spout, less halfband
10	18987	18987	Tube halfband
11	18988	18988	Truss support bracket, low
12	27534	27534	Truss support bracket, high
13	17032	17032	Truss cable
14	17017	17017	Track stop
15	18989	18989	Truss attach angle
16	18035	18035	Hydraulic cylinder, w/pulleys & cable
17	18044	18044	5/16" Lift cable
18	19333	19333	5/16" Cable clamp
19	18990	18990	3/8" Cable clamp
20	17033	17033	Upper lift tube, left or right
21	17034	17034	Upper lift bundle, as shipped
22	18993	18993	Brace clamp
23	17035	17035	Lower reach tube, left
24	17036	17036	Lower reach tube, right
25	17037	17037	Lower reach frame bundle, as shipped
26	17038	17038	Axle, w/spindles, nuts, cotter pins
27	17004	17004	Weld on spindle
28	17039	17039	Crossmember
29	18999	18999	Short crossmember
30	17000	17000	Stabilizer brace
31	27546	27546	Stabilizer bracket
32	17002	17002	Cross brace
33	18518	18518	1-3/4" Bearing, 4 bolt
34	17005	17005	Track shoe
35	17024	17024	Cable roller
36	17006	17006	Seal
37	17007	17007	Large bearing, Timken no. LM29749
38	17008	17008	Large cup, Timken no. LM29710
39	17009	17009	Hub w/cups
40	19266	19266	Small cup, Timken no. LM67010
41	19265	19265	Small bearing, Timken no. LM67048
42	17010	17010	Washer

MK130/MK130^{PLUS} - 81' Basic Auger

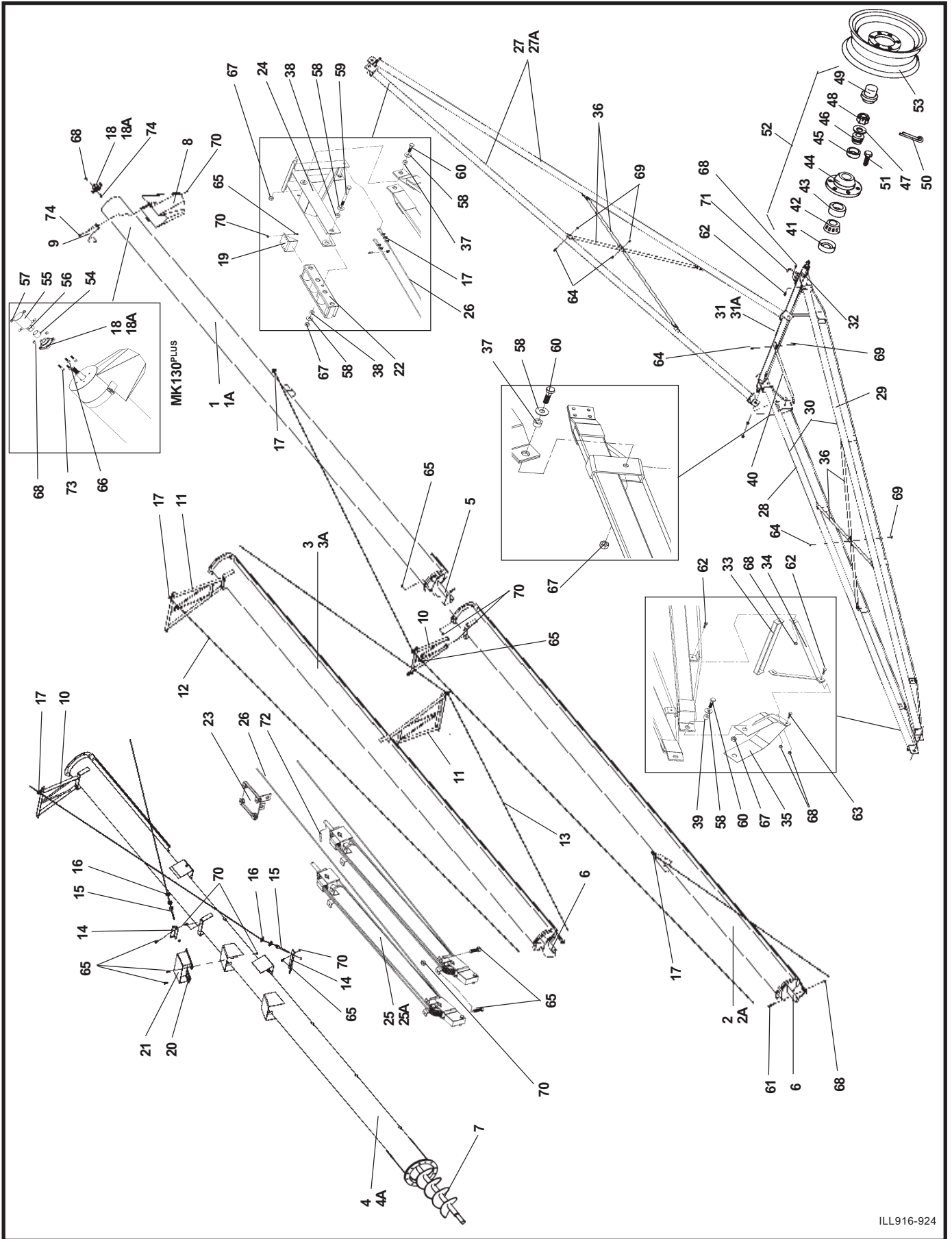

ILL916-924

MK130/MK130^{PLUS} - 81' Basic Auger

REF. NO.	PART NO.		PART DESCRIPTION
	MK130-81	MK130 ^{PLUS} -81	
39	17563	17563	Spacer bushing, 1-1/8" long
40	17463	17463	Corner brace
41	17006	17006	Seal
42	17007	17007	Large bearing, Timken no. LM29749
43	17008	17008	Large cup, Timken no. LM29710
44	17009	17009	Hub w/cups
45	19266	19266	Small cup, Timken no. LM67010
46	19265	19265	Small bearing, Timken no. LM67048
47	17010	17010	Washer
48	17011	17011	Slotted nut, 1"
49	17012	17012	Dust cap
50	19271	19271	Cotter pin, 1/8" x 1-1/2"
51	17561	17561	Wheel bolt, 1/2" - 20 x 1-5/8"
52	17013	17013	Hub assembly, complete
53	17560	17560	15" Wheel, 6 bolt
54	---	27575	Bushing, Thrust adjuster
55	---	27576	Thrust adjuster cover
56	---	27587	NF hex nut, 1-1/2"
57	---	27588	Washer locknut, 5/8"
58	17020	17020	Washer, 1"
59	17015	17015	Bolt, 1" - 8 x 10", grade 8
60	17016	17016	Bolt, 1" - 8 x 3-1/2", grade 8
61	18545	18545	Bolt, 5/8" - 11 x 4-1/2", grade 8
62	19991	19991	Bolt, 5/8" - 11 x 2", grade 8
63	19590	19590	Bolt, 5/8" - 11 x 1-1/2", grade 8
64	19588	19588	Bolt, 1/2" - 13 x 1-1/4", grade 5
65	18698	18698	Bolt, 7/16" - 14 x 1-1/4", grade 5
66	18544	18544	Bolt, 5/8" - 11 x 1-3/4", grade 5
67	17019	17019	Locknut, 1" - 8
68	19600	19600	Locknut, 5/8" - 11
69	19599	19599	Locknut, 1/2" - 13
70	19598	19598	Locknut, 7/16" - 14
71	19648	19648	Saddle pin
72	18079	18079	Roll pin, 5/16" x 2"
73	---	27589	Bolt, 5/8" - 11 x 2-1/2", grade 5
74	19981	19981	Bolt, 7/16" - 14 x 1-3/4", grade 5

REF. NO.	PART NO.		PART DESCRIPTION
	MK130-81	MK130 ^{PLUS} -81	
1	18977	18977	Upper tube section
1A	18978	18978	Upper tube bundle, as shipped
2	18979	18979	Upper middle tube section
2A	18980	18980	Upper middle tube bundle, as shipped
3	27527	27527	Lower middle tube section
3A	27536	27536	Lower middle tube bundle, as shipped
4	27526	27526	Lower tube section
4A	27537	27537	Lower tube bundle, as shipped
5	18983	27591	Upper flight section
6	18984	18984	Middle flight section
7	18985	18985	Lower flight section
8	18986	18986	Spout less halfband
9	18987	18987	Halfband
10	18988	18988	Truss support bracket, low
11	27534	27534	Truss support bracket, high
12	27501	27501	Truss cable, upper
13	27502	27502	Truss cable, lower
14	18989	18989	Truss attach angle, lower
15	19331	19331	Eye bolt w/nut
16	18990	18990	3/8" cable clamp
17	19333	19333	5/16" cable clamp
18	18518	18518	1-3/4" Bearing, 4 bolt
18A	17527	17527	1-3/4" Bearing, less flange
19	17462	17462	Track stop
20	27522	27522	Lift arm extension bracket
21	27488	27488	Lift arm extension
22	17461	17461	Track shoe
23	27562	27562	Ram guide
24	17455	17455	Lift assist bracket
25	27535	27535	Hydraulic cylinder w/pulleys & cable
25A	27541	27541	Hydraulic cylinder only
26	17380	17380	5/16" Lift cable, 86' 6" long
27	27531	27531	Upper lift arm, left or right
27A	27539	27539	Upper lift bundle, as shipped
28	27529	27529	Lower reach arm, left
29	27528	27528	Lower reach arm, right
30	27538	27538	Lower reach frame bundle, as shipped
31	27530	27530	Axle base
31A	27540	27540	Axle bundle, as shipped, including ref #36
32	27490	27490	Axle extension
33	27532	27532	Short cross member
34	27525	27525	Stabilizer brace
35	27546	27546	Stabilizer bracket
36	27500	27500	Cross brace
37	27507	27507	Spacer bushing, 7/8" long
38	27508	27508	Spacer bushing, 5/8" long

MK100/MK130/MK130^{PLUS}-91' & MK130/MK130^{PLUS}-111' Basic Tubes

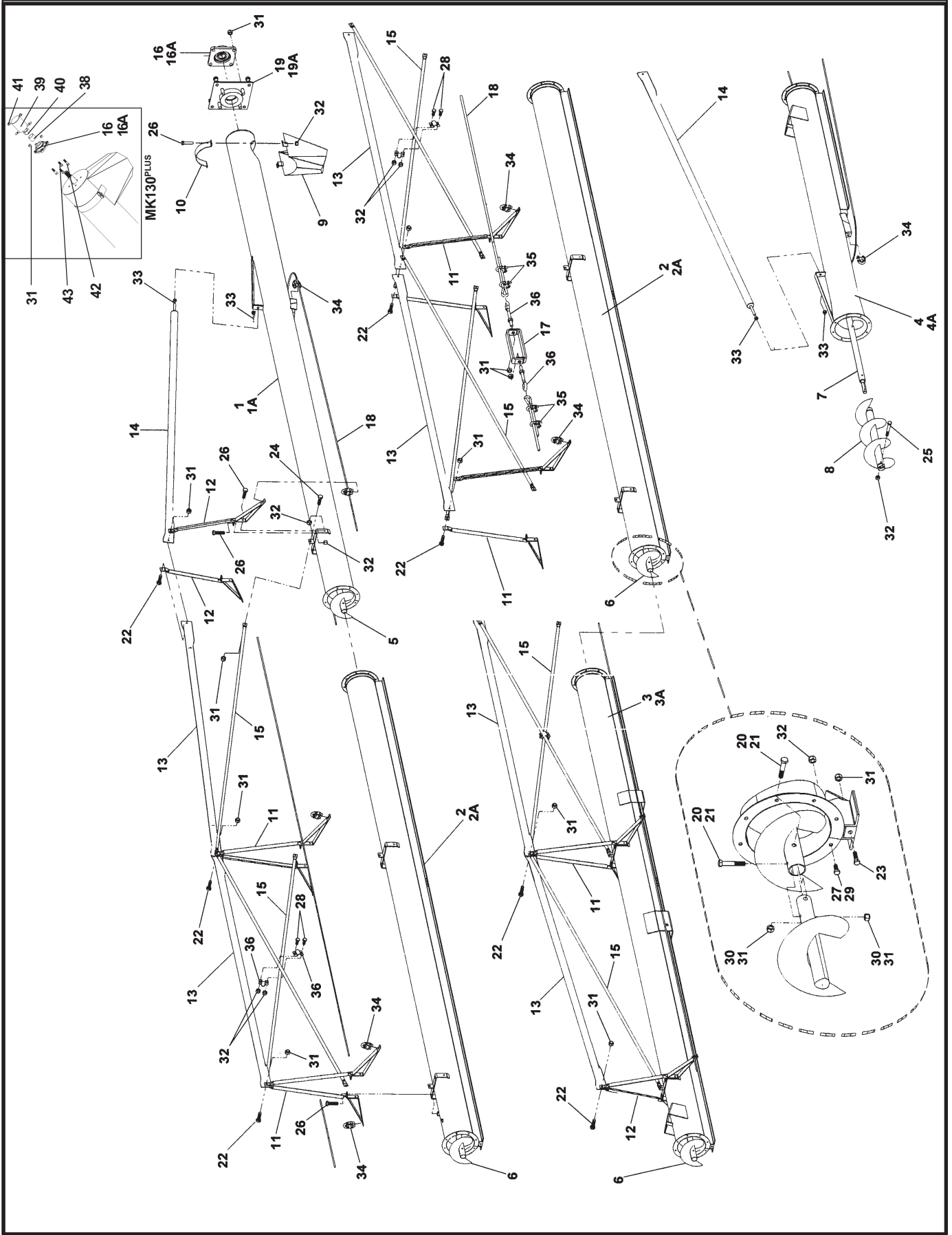

MK100/MK130/MK130^{PLUS}-91' & MK130/MK130^{PLUS}-111' Basic Tubes

REF NO.	PART NO.				PARTS DESCRIPTION
	MK100-91	MK130-91	MK130 ^{PLUS} -91	MK130-111	
1	17564	17565	17565	17565	Upper tube section
1A	17505	17506	17506	17506	Upper tube bundle, as shipped
2	17566	17567	17567	17567	Upper middle tube section
2A	17507	17508	17508	17508	Upper middle tube bundle, as shipped
3	17568	17569	17569	17654	Lower middle tube section
3A	17509	17510	17510	17673	Lower middle tube bundle, as shipped
4	17570	17571	17571	17571	Lower tube section
4A	17511	17512	17512	17512	Lower tube bundle, as shipped
5	17587	18983	27591	18983	Upper flight section
6	17588	18984	18984	18984	Middle flight section
7	17575	17030	17030	17030	Lower flight
8	18921	—	—	—	Intake flight section
9	18029	18986	18986	18986	Spout, less halfband
10	19801	18987	18987	18987	Tube halfband
11	17460	17460	17460	17460	Truss support bracket, high
12	17459	17459	17459	17459	Truss support bracket, low
13	17572	17572	17572	17658	Truss tube
14	17573	17573	17573	17660	Truss adjust tube
15	17574	17574	17574	17659	Truss cross brace
16	19567	—	—	—	1-1/4" Bearing w/4-bolt flange
16	—	18518	18518	18518	1-3/4" Bearing w/4-bolt flange
16A	18852	—	—	—	1-1/4" Bearing, less flange
16A	—	17527	17527	17527	1-3/4" Bearing, less flange
17	17464	17464	17464	17464	Turn buckle (2 required per set)
18	17576	17576	17576	—	3/8" Truss cable, single 80' 0"
18	—	—	—	17653	3/8" Truss cable, single 106' 0"
19	17385	—	—	—	Thrust adjuster assembly, less bearing
19A	17577	—	—	—	Foam gasket only
20	—	18545	18545	18545	Bolt, 5/8" - 11 x 4-1/2", grade 8
21	19798	—	—	—	Bolt, 1/2" - 13 x 2-3/4", grade 8
22	17403	17403	17403	17403	Bolt, 1/2" - 13 x 2-1/2", grade 5
23	19589	19589	19589	19589	Bolt, 1/2" - 13 x 1-1/2", grade 5
24	19588	19588	19588	19588	Bolt, 1/2" - 13 x 1-1/4", grade 5
25	19547	—	—	—	Bolt, 7/16" - 14 x 3-1/2", grade 5
26	18698	18698	18698	18698	Bolt, 7/16" - 14 x 1-1/4", grade 5
27	—	18698	18698	18698	Bolt, 7/16" - 14 x 1-1/4", grade 5
28	19542	19542	19542	19542	Bolt, 7/16" - 14 x 1", grade 5
29	19542	—	—	—	Bolt, 7/16" - 14 x 1", grade 5
30	19600	19600	19600	19600	Locknut, 5/8" - 11
31	19599	19599	19599	19599	Locknut, 1/2" - 13
32	19598	19598	19598	19598	Locknut, 7/16" - 14
33	19997	19997	19997	19997	Hexnut, 3/4" - 10
34	19333	19333	19333	19333	Cable clamp, 5/16"
35	18990	18990	18990	18990	Cable clamp, 3/8"
36	17405	17405	17405	17655	Cross brace clamp, single

REF NO.	PART NO.				PARTS DESCRIPTION
	MK100-91	MK130-91	MK130 ^{PLUS} -91	MK130-111	
37	19331	19331	19331	19331	Eyebolt, 1/2" - 13 x 5" w/locknut
38	—	—	27575	27575	Bushing, Thrust adjuster
39	—	—	27576	27576	Thrust adjuster cover
40	—	—	27587	27587	NF hex nut, 1-1/2"
41	—	—	27588	27588	Washer locknut, 5/8"
42	—	—	27589	27589	Bolt, 5/8" - 11 x 2-1/2", grade 5
43	—	—	18544	18544	Bolt, 5/8" - 11 x 1-3/4", grade 5

MK100 / MK130 - 91' & MK130 - 111' Basic Frame

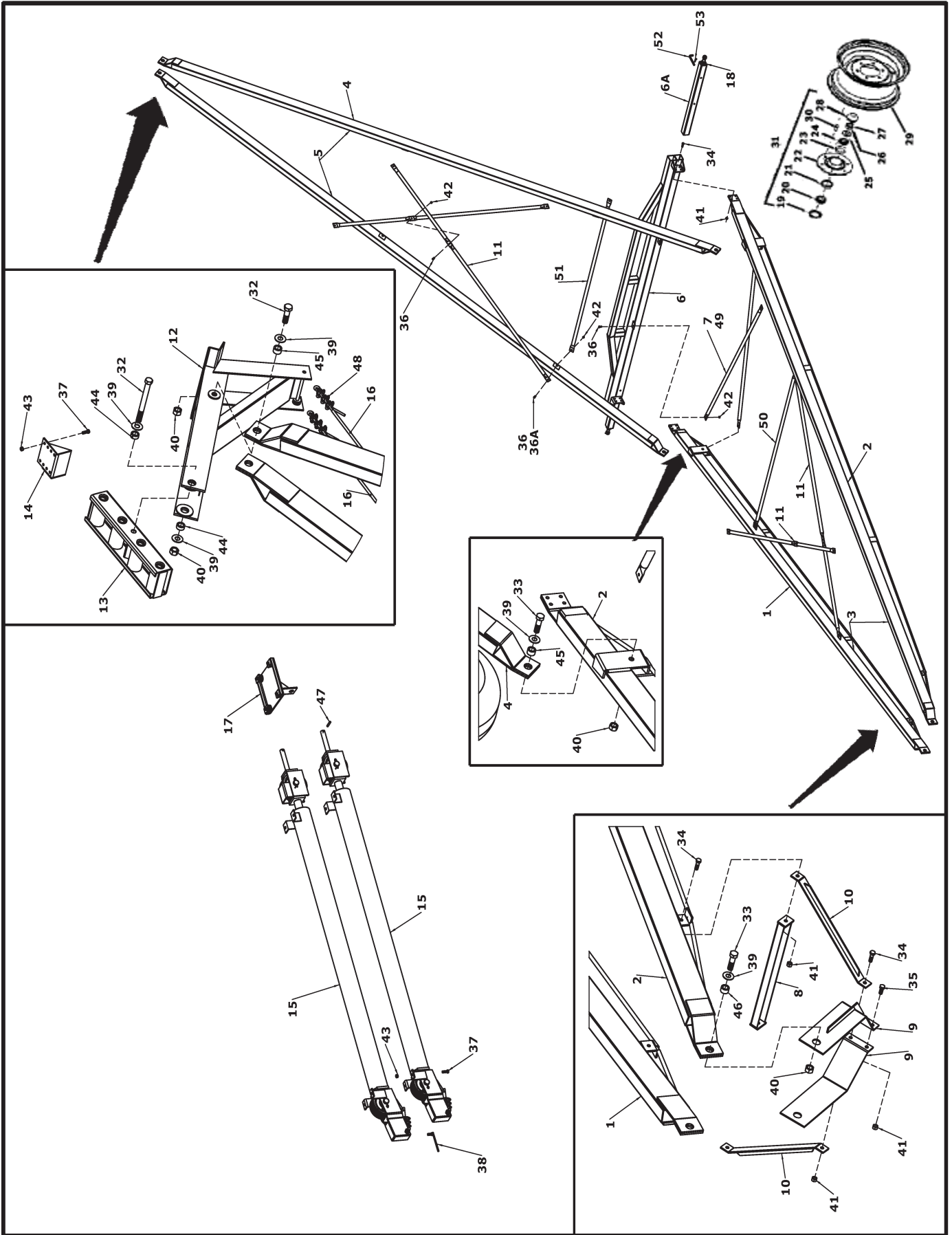

MK100 / MK130 - 91' & MK130 - 111' Basic Frame

REF. NO.	PART NO.		PARTS DESCRIPTION
	MK91	MK111	
39	17020	17020	Flat washer, 1"
40	17019	17019	Locknut, 1" - 8
41	19600	19600	Locknut, 5/8" - 11
42	19599	19599	Locknut, 1/2" - 13
43	19598	19598	Locknut, 7/16" - 14
44	17021	17021	Spacer bushing, 11/16" long
45	17022	17022	Spacer bushing, 15/16" long
46	17563	17563	Spacer bushing, 1-1/8" long
47	18079	18079	Roll pin, 5/16" x 2"
48	19333	--	Cable clamp, 5/16"
48A	--	18990	Cable clamp, 3/8"
49	--	28439	Axle brace (111' only)
50	--	28438	Lower tie tube (111' only)
51	--	28439	Upper tie tube (111' only)
52	19648	19648	Saddle Pin
53	19463	19463	Hitch Pin
1	17555	17643	Before July 2008: Lower reach tube, left
2	17556	17644	Lower reach tube, right
3	17515	17666	Lower reach frame bundle, as shipped
4	17557	17645	Upper lift tube, left or right
5	17514	17665	Upper lift bundle, as shipped
6	17513	17642	Axle w/spindle, nuts, cotter pins
8	18999	18999	Short crossmember
10	17000	17000	Stabilizer brace
49	--	17647	Axle brace (111' only)
50	--	17647	Lower tie tube (111' only)
51	--	17648	Upper tie tube (111' only)

REF. NO.	PART NO.		PARTS DESCRIPTION
	MK91	MK111	
1	28307	28435	Lower reach tube, left
2	28306	28434	Lower reach tube, right
3	28327	28590	Lower reach frame bundle, as shipped
4	28308	28436	Upper lift tube, left or right
5	28328	28591	Upper lift bundle, as shipped
6	28310	28433	Axle Weldment
6A	28311	28311	Axle Extension
7	17463	--	Corner brace (91' only)
8	28325	28325	Short cross member
9	27546	27546	Stabilizer bracket
10	28326	28326	Stabilizer brace
11	17558	17646	Cross brace
12	17455	17455	Lift assist bracket
13	17461	17461	Track shoe
14	17462	17462	Track stop
15	17466	17650	Hydraulic cylinder w/pulleys and cables
16	17380	--	5/16" Lift cable, 86'6" long
16A	--	17653	3/8" Lift cable, 106' long
17	27562	27562	Cylinder ram guide
18	17004	17004	Weld on spindle
19	17006	17006	Seal
20	17007	17007	Large bearing, Timken no. LM29749
21	17008	17008	Large cup, Timken no. LM29710
22	17009	17009	Hub w/cups
23	19266	19266	Small cup, Timken no. LM67010
24	19265	19265	Small bearing, Timken no. LM67048
25	17010	17010	Washer
26	19271	19271	Cotter pin, 1/8" x 1-1/2"
27	17011	17011	Slotted nut, 1"
28	17012	17012	Dust cap
29	17560	17560	15" Wheel, 6 bolt
30	17561	17561	Wheel bolt, 1/2" - 20 x 1-5/8"
31	17013	17013	Hub assembly, complete
32	17015	17015	Bolt, 1" - 8 x 10", grade 8
33	17016	17016	Bolt, 1" - 8 x 3-1/2", grade 8
34	19991	19991	Bolt, 5/8" - 11 x 2", grade 8
35	19590	19590	Bolt, 5/8" - 11 x 1-1/2", grade 8
36	19588	--	Bolt, 1/2" - 13 x 1-1/4", grade 5
36A	--	19974	Bolt, 1/2" - 13 x 1-3/4", grade 5
37	18698	18698	Bolt, 7/16" - 14 x 1-1/4", grade 5
38	17562	17562	Bolt, 7/16" - 14 x 1-1/4", grade 5 w/handle

Swing Hopper

MK80 / MK100 / MK130 / MK130^{PLUS}

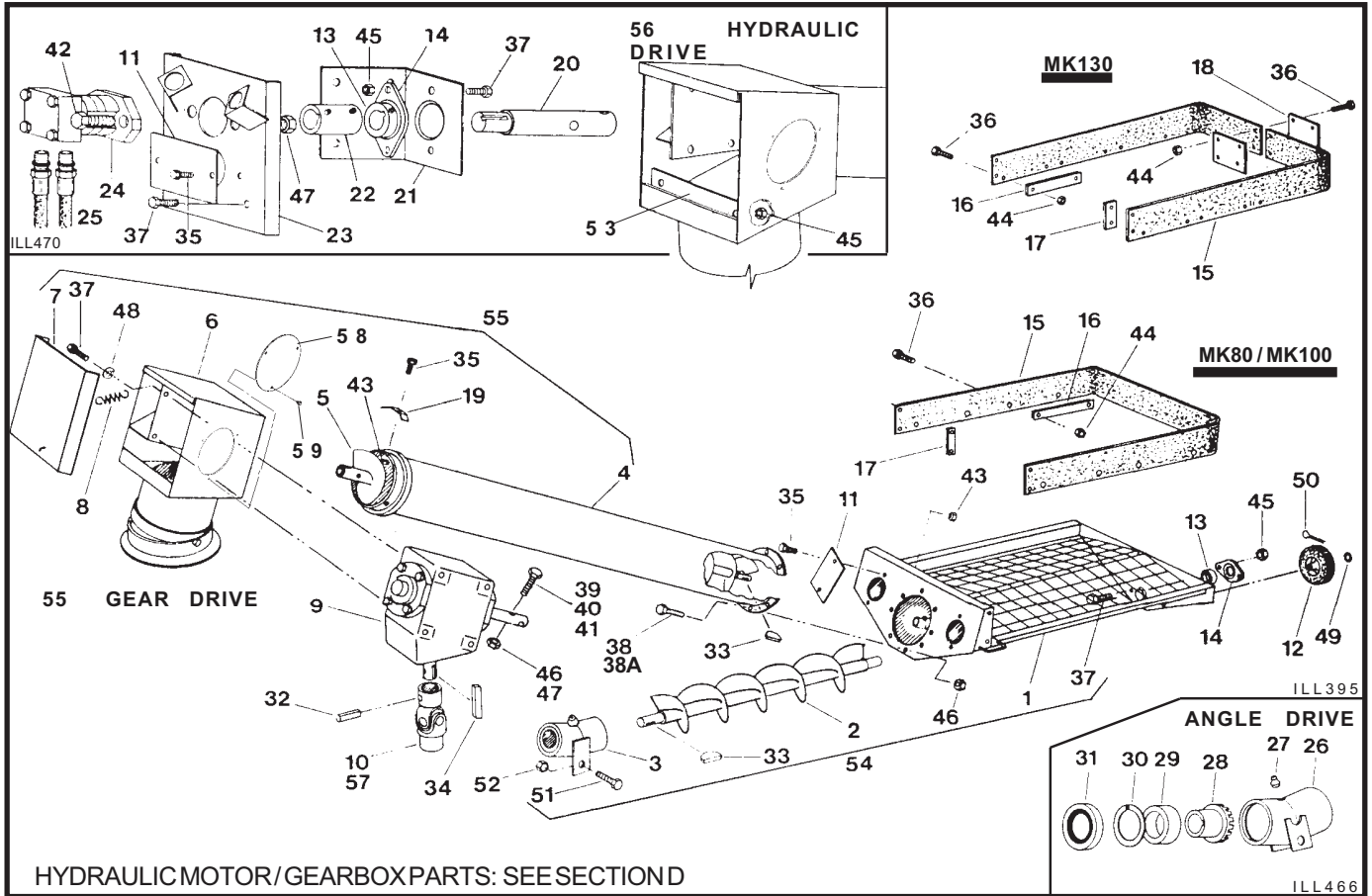

HYDRAULIC MOTOR/GEARBOX PARTS: SEE SECTION D

REF NO.	PART NO.				PARTS DESCRIPTION
	MK80	MK100	MK130	MK130 ^{PLUS}	
1	18861	18862	18590	18590	Intake hopper
2	18869	18870	18591	18591	Hopper flighting
3	18860	18860	18860	18860	Angle drive
4	18865	18866	18931	18931	Tube section
5	18871	18872	18932	18932	Tube flighting
6	18867	18868	18933	27565	Spout head
7	18875	18876	18934	27567	Spout door
8	18728	18728	18728	18728	Door spring
9	18848	18849	18789	27560	Upper gearbox
10	18727	18727	18727	18727	Universal joint
11	18874	18874	18874	18874	Access plate
12	18056	18056	18935	18935	Wheel
13	18853	18853	18853	18853	1-1/4" Bearing, less flanges
14	18695	18695	18695	18695	1-1/4" Flangette
15	18873	18873	18936	18936	Rubber extension
16	18054	18054	18054	18054	Attach strap, 13"
17	18878	18878	18878	18878	Attach strap, 4-1/2"
18	--	--	18055	18055	Connector plate
19	18877	18877	18877	18877	Stop plate
20	18937	18938	--	--	Shaft
21	18939	18939	--	--	Bracket
22	19119	19119	--	--	Drive connector
23	18940	18941	--	--	Mount plate
24	18065	18066	--	--	Hydraulic motor
25	18067	18067	--	--	1/2" Hydraulic hose
26	18942	18942	18942	18942	Housing
27	19222	19222	19222	19222	Grease fitting
28	18943	18943	18943	18943	Gear
29	18944	18944	18944	18944	Bushing
30	18945	18945	18945	18945	Retaining ring

REF NO.	PART NO.				PARTS DESCRIPTION
	MK80	MK100	MK130	MK130 ^{PLUS}	
31	18946	18946	18946	18946	Angle drive seal
32	18079	18079	18079	18079	Roll pin, 5/16" x 2"
33	19224	19224	19224	19224	Woodruff key, 1/4" x 1"
34	19606	19606	19606	19606	Square key, 1/4" x 1-1/2"
35	19537	19537	19537	19537	Bolt, 1/4" - 20 x 1/2", grade 5
36	19538	19538	19538	19538	Bolt, 5/16" - 18 x 3/4", grade 2
37	19540	19540	19540	19540	Bolt, 3/8" - 16 x 3/4", grade 2
38	19542	19542	--	--	Bolt, 7/16" - 14 x 1", grade 5
38A	--	--	18698	18698	Bolt, 7/16" - 14 x 1-1/4", grade 5
39	19545	--	--	--	Bolt, 7/16" - 14 x 2-1/4", grade 8
40	--	17747	--	--	Bolt, 7/16" - 14 x 2-1/2", grade 8
41	--	--	18947	18947	Bolt, 1/2" - 13 x 4", grade 8
42	19589	19589	--	--	Bolt, 1/2" - 13 x 1-1/2", grade 2
43	19594	19594	--	--	Washer locknut, 1/4" - 20
44	19595	19595	19595	19595	Washer locknut, 5/16" - 18
45	19596	19596	19596	19596	Washer locknut, 3/8" - 16
46	19598	19598	19598	19598	Locknut, 7/16" - 14
47	19599	19599	19599	19599	Locknut, 1/2" - 13
48	19604	19604	19604	19604	Lockwasher, 3/8"
49	18096	18096	18948	18948	Rim washer
50	19271	19271	19271	19271	Cotter pin, 1/8" x 1-1/2"
51	18955	18955	18955	18955	Bolt, 3/8" - 16 x 1", grade 2
52	18956	18956	18956	18956	Locknut, 3/8"
53	18957	18958	--	--	Attach strap
54	18863	18864	18949	18949	Hopper assembly, as shipped
55	18950	18951	18952	27568	Tube assm, gear dr, as shipped
56	18953	18954	--	--	Tube assm, hyd. dr, as shipped
57	17029	17029	17029	17029	Repair kit, universal joint
58	17374	17374	17374	17374	Gearbox access cover
59	19274	19274	19274	19274	Flat tip selftapping screw
60	17140	--	--	--	S08/10-6/9 carton

MK100 / MK130

Low Profile Hopper

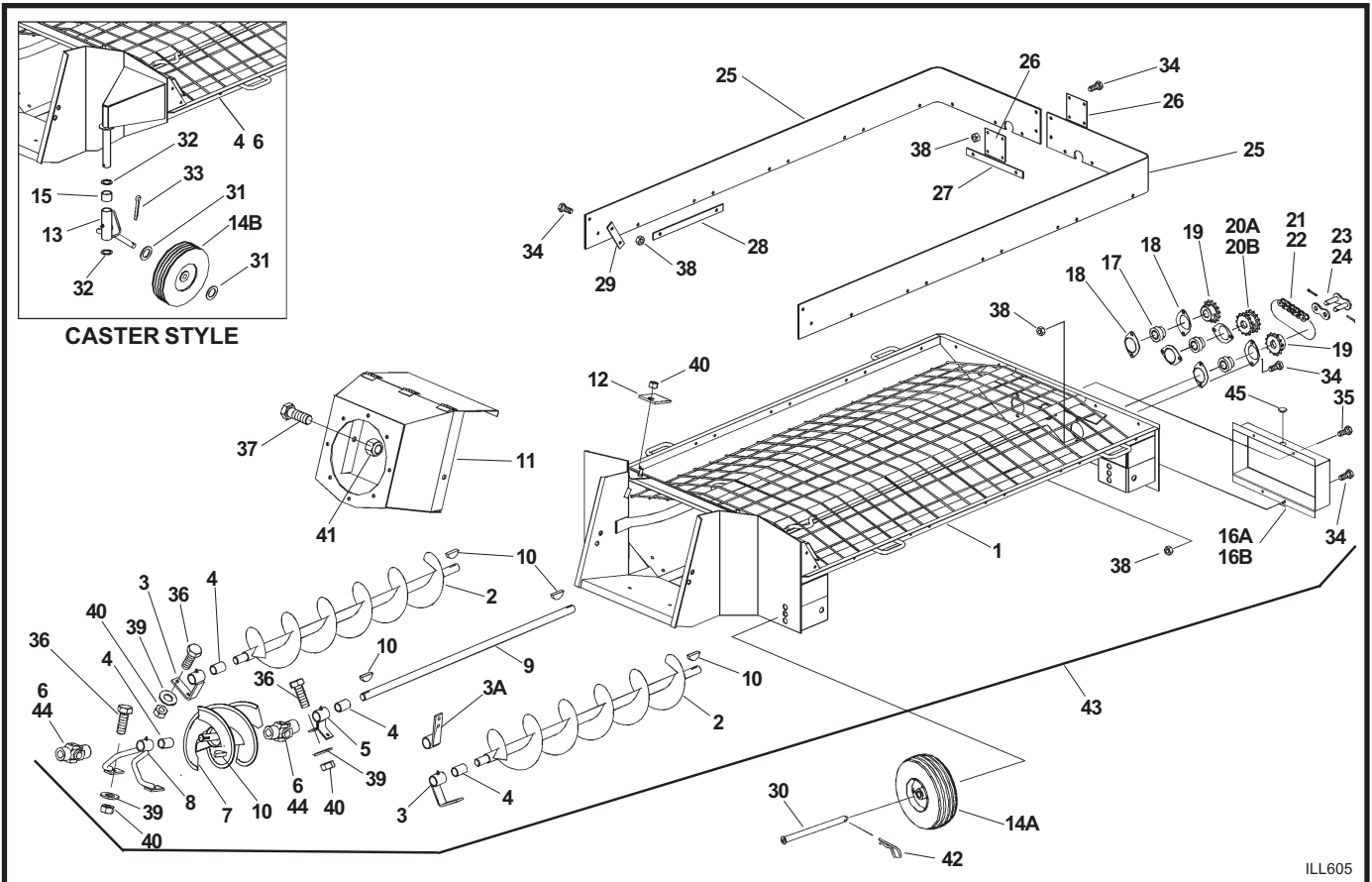

ILL605

REF. NO.	PART NO.		PARTS DESCRIPTION	NO. REQD
	10"	13"		
1	17393	17393	Intake hopper	1
2	17345	17345	Hopper flighting	2
3	17351	17351	Bottom mount bushing support, w/bushing	2
3A	17583	17583	Top mount bushing support, w/bushing	2
4	19149	19149	Bushing only	4
5	17352	17352	Center shaft bushing support, w/bushing	1
6	19290	19290	Universal joint	2
7	17356	17355	Pivot connector flighting	1
8	17354	17353	Center flighting bushing support, w/bushing	1
9	17346	17347	Center drive shaft	1
10	19224	19224	Woodruff key, 1/4" x 1"	6
11	17360	17361	Pivot connector	1
12	17362	17362	Latch	2
13	17359	17359	Caster weldment	3
14A	17522	17522	Wheel c/w tire	4
14B	18056	18056	Wheel (caster style)	6
15	17387	17387	Spacer	3
16A	17350	17350	Chain guard (caster style)	1
16B	17397	17397	Chain guard	1
17	18817	18817	Bearing	3
18	18694	18694	Flangette, single	6
19	19131	19131	Sprocket #50-14t, single	2
20A	17348	--	Sprocket #50-14t, double	1
20B	--	17349	Sprocket #50-20t, double	1
21	17368	--	Roller chain w/conn. link (32 pitches)	2
22	--	17369	Roller chain w/half & conn. links (35 pitches)	2

REF. NO.	PART NO.		PARTS DESCRIPTION	NO. REQD
	10"	13"		
23	19134	19134	Roller chain connector only	2
24	--	17389	Roller chain half link only	2
25	17357	17357	Rubber extension	2
26	18055	18055	Connector plate, single	2
27	17358	17358	Attach strap, 10-1/2"	3
28	18054	18054	Attach strap, 13"	8
29	18878	18878	Attach strap, 4-1/2"	2
30	17394	17394	Axle	4
31	18096	18096	Rim washer, 5/8"	12
32	18097	18097	Rim washer, 1"	6
33	19271	19271	Cotter pin, 1/8" x 1-1/2"	9
34	19538	19538	Bolt, 5/16" - 18 x 3/4", grade 2	36
35	18091	18091	Bolt, 5/16" - 18 x 1", grade 2	2
36	19955	19955	Bolt, 3/8" - 16 x 1", grade 2	8
37	19590	19590	Bolt, 5/8" - 11 x 1-1/2"	2
38	19595	19595	Washer locknut, 5/16" - 18	38
39	17392	17392	Flat washer, 3/8" SAE	8
40	18956	18956	Locknut, 3/8" - 16	10
41	19600	19600	Locknut, 5/8" - 11	2
42	19463	19463	Hairpin	4
43	17518	17519	Hopper assembly, as shipped	X
44	19235	19235	Repair kit, universal joint	X
45	17584	17584	Plastic plug	1
46	17344	17344	Hopper only (caster style)	1
47	17896	17896	LP innertube	
48	17862	17862	LP hopper tire only	

MK80 / MK100 / MK130 / MK130^{PLUS} Boot & Hopper Lift Assembly

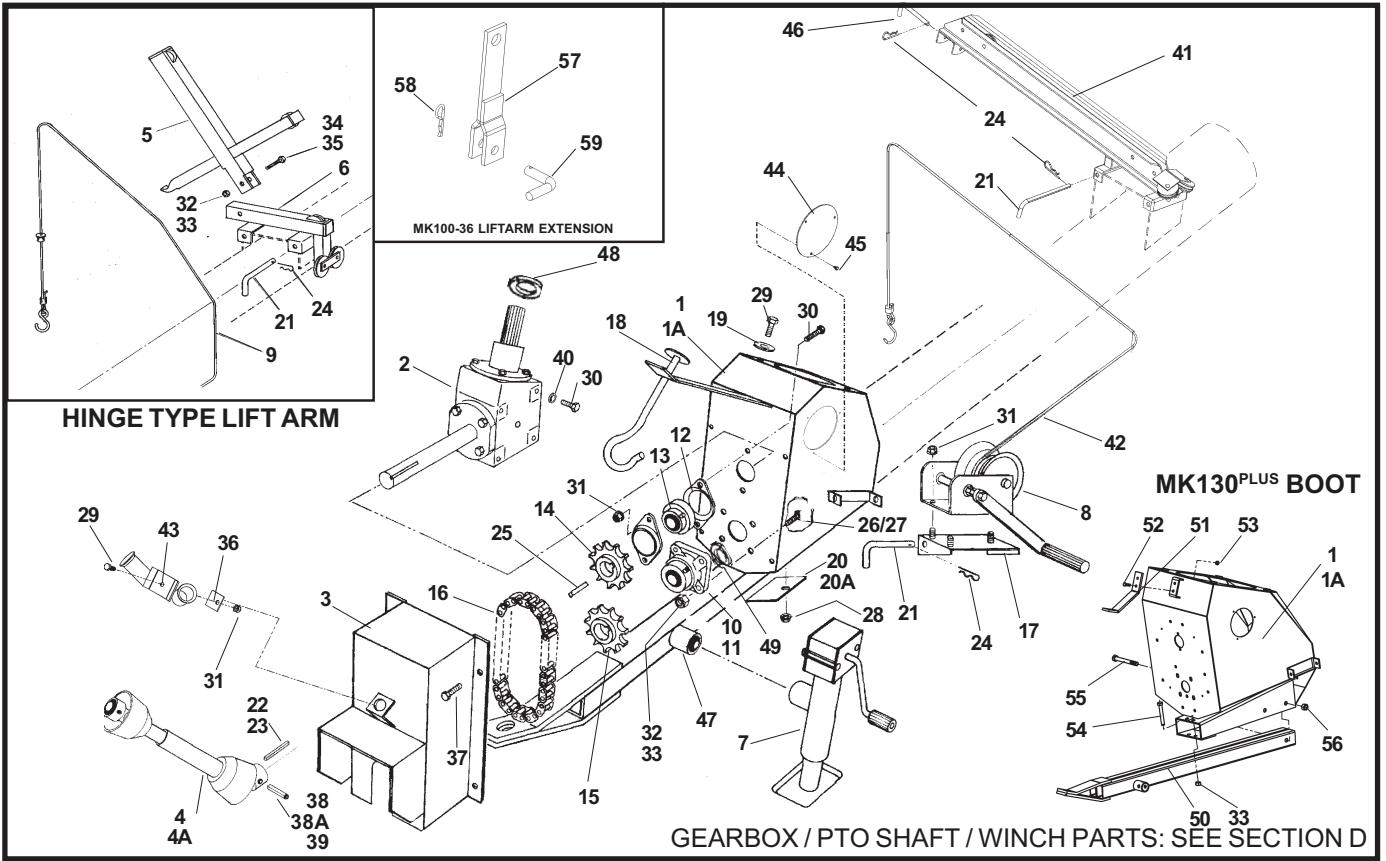

REF NO.	PART NO.				PARTS DESCRIPTION
	8"	10"	13"	13" ^{PLUS}	
1	18742	18743	18488	27563	Boot, less bearings
1A	17450	17451	17452	27566	Boot assembly, as shipped
2	18850	18851	18790	27561	Lower gearbox
3	18744	18744	18540	18540	Sprocket cover
4	18484	18484	18455	18455	PTO shaft
4A	--	27481	17542	17542	PTO shaft MK91' only
5	18746	18746	18506	--	Hopper liftarm Hinge type
6	18750	18750	18507	--	Hopper lift base Hinge type
7	18080	18080	18080	18080	Sidewinderjack
8	19141	19141	19152	19152	Winch
9	18491	18491	18502	--	Hopper lift cable Hinge type
10	19567	19567	18518	18518	Bearing assembly
11	18852	18852	17527	17527	Bearing insert only
12	18695	18695	18695	18695	1-1/4" Flangette
13	18853	18853	18853	18853	1-1/4" Bearing, less flanges
14	18710	18713	19779	19779	Upper sprocket
15	18710	18713	18525	18525	Lower sprocket
16	18725	18726	19781	19781	Roller chain (MK130 with reverser add one 17400 - half link)
17	18076	18076	18536	18536	Winch mount
18	18754	18754	18537	18537	Transport saddle
19	18792	18792	18792	18792	Hold down washer
20	18757	18757	18757	18757	Clean out plate - 4" x 4-1/2"
20A	17373	17372	17372	17372	Clean out plate - full length
21	18074	18074	18074	18074	Mount pin
22	19607	19607	--	--	Square key, 1/4" x 3"
23	--	--	18541	18541	Square key, 3/8" x 3-1/2"
24	19463	19463	19463	19463	Hair pin
25	19606	19606	19606	19606	Square key, 1/4" x 1-1/2"
26	19589	19589	--	--	Bolt, 1/2" - 13 x 1-1/2", grade 5
27	--	--	18544	18544	Bolt, 5/8" - 11 x 1-3/4", grade 5
28	19595	19595	19595	19595	Washer locknut, 5/16"

REF NO.	PART NO.				PARTS DESCRIPTION
	8"	10"	13"	13" ^{PLUS}	
29	18184	18184	18184	18184	Bolt, 3/8" - 16 x 3/4", grade 5
30	19540	19540	19540	19540	Bolt, 3/8" - 16 x 3/4", grade 2
31	19596	19596	19596	19596	Washer locknut, 3/8" - 16
32	19599	19599	--	--	Locknut, 1/2" - 13
33	--	--	19600	19600	Locknut, 5/8" - 11
34	18092	18092	--	--	Bolt, 1/2" - 13 x 3-1/2", grade 5
35	--	--	18545	18545	Bolt, 5/8" - 11 x 4", grade 5
36	--	17362	17362	17362	Square washer MK91' only
37	19538	19538	19538	19538	Bolt, 5/16" - 11 x 3/4", grade 2
38	18079	18079	--	--	Roll pin, 5/16" x 2"
38A	--	28584	--	--	Roll pin, 5/16" x 2-1/2" (MK81-91 only)
39	--	--	18546	18546	Roll pin, 3/8" x 2-1/2"
40	19604	19604	19604	19604	Lock washer, 3/8"
41	17363	17363	17363	17363	Hopper liftarm
42	17376	17376	17376	17376	Cable 1/4" dia x 31' long
43	--	17467	17467	17467	Double hose holder MK91' only
44	17374	17374	17374	17374	Gearbox access cover
45	17543	17543	17543	17543	Flat tip selftapping screw
46	19648	19648	19648	19648	Saddle pin
47	18116	18116	18116	18116	Pipe mount, weld-on
48	17370	17370	17370	--	Rim washer
49	17370	17370	17371	17371	Rim washer
50	--	--	--	27564	Tow bar
51	--	--	--	27569	PTO bar
52	--	--	--	18698	Bolt, 7/16" - 14 x 1-1/4", grade 8
53	--	--	--	17753	Locknut, 7/16" - 14
54	--	--	--	17065	Bolt, 5/8" - 11 x 4-1/2", grade 5
55	--	--	--	19593	Bolt, 3/4" - 10 x 6-1/2", grade 5
56	--	--	--	19601	Locknut, 3/4" - 10
57	--	28293	--	--	Hopper lock
58	19463	19463	19463	19463	Hair pin
59	27192	27192	--	--	Shifter lock pin

MK80, MK100, MK130, W130

Hydraulic Lift Cylinder

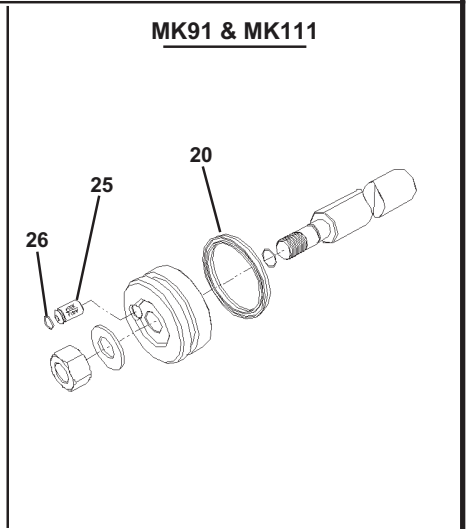
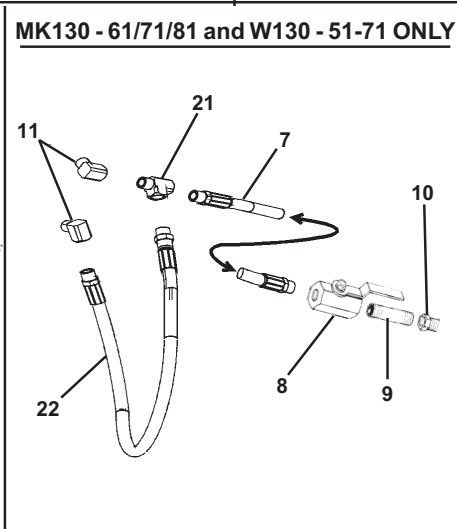
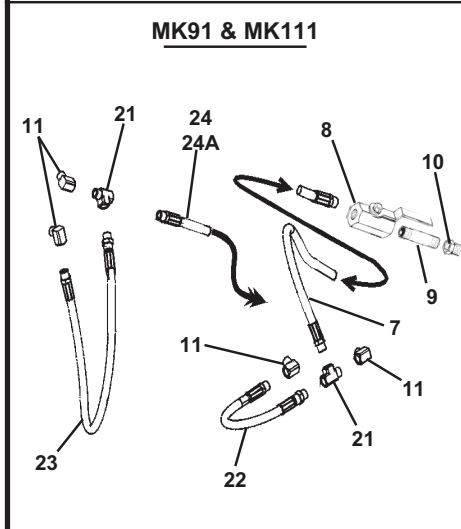
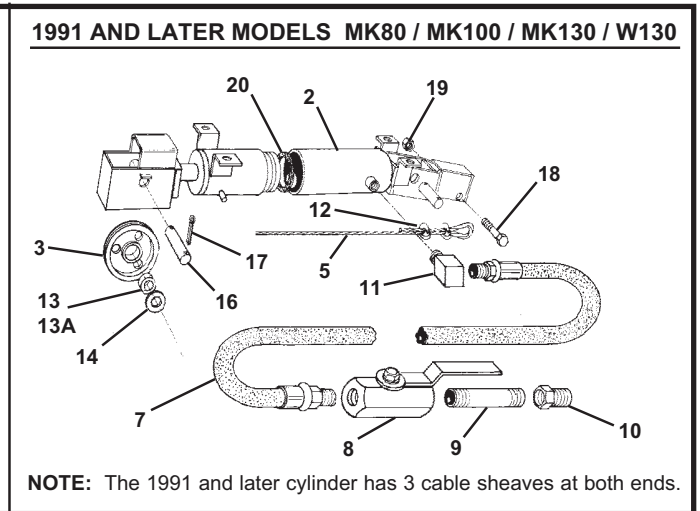
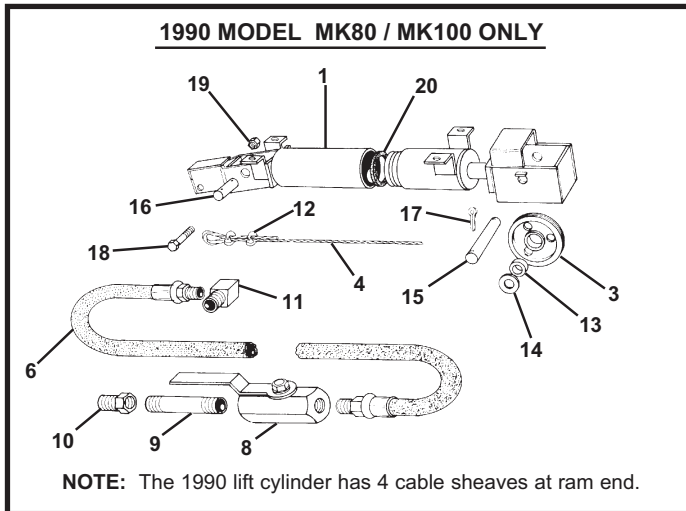

REF. NO.	PART NO.						PARTS DESCRIPTION
	MK51	MK61	MK71	MK81	MK91	MK111	
1	18547	18548	18549	--	--	--	Hydraulic cylinder 1990 models only
2	19915	19916	19917	27505	17388	17649	Hydraulic cylinder only (FOR MK1381, USE 27541)
3	19918	19918	19918	17640	19918	17640	Pulley, 5-1/2" dia. w/bushing (MK111 & MK81: 6" dia.)
4	18189	18923	18924	--	--	--	Cable, 5/16" dia. 1990 models only
5	18042	18043	18044	27503	17380	17653	Cable, 5/16" dia. (MK111 & MK81: 3/8" dia.)
6	18082	18550	18701	--	--	--	Hydraulic hose 1990 models only
7	18081	18082	18083	18083	17559	17656	Hydraulic hose
8	18084	18084	18084	18084	18084	18084	Shut-off valve, 3/8"
9	18085	18085	18085	18085	18085	18085	Pipe nipple, 3/8" x 4-3/4"
10	18086	18086	18086	18086	18086	18086	Reducer bushing, 3/8" x 1/2"
11	18087	18087	18087	18087	18087	18087	Street elbow, 3/8"
12	19333	19333	19333	18990	19333	17653	Cable clamp, 5/16" (MK111 & MK81: 3/8")
13	18088	18088	18088	--	18088	--	Bushing, 1" x 3/4" long
13A	--	--	--	17687	--	17687	Bushing, 1" x 7/8" long
14	18097	18097	18097	18097	18097	17651	Rim washer, 1" (MK111: 1-1/4")
15	18732	18732	18732	--	--	--	Pulley Pin, 1" x 5" 1990 models only
16	18089	18089	18089	18089	18089	17652	Pulley Pin, 1" x 4-1/4" (MK111: 1-1/4" x 4-1/2")
17	18098	18098	18098	18098	18098	18098	Cotter pin, 1/4" x 1-3/4"
18	18093	18093	18093	18093	18093	18093	Bolt, 5/8" - 11 x 3-1/2", grade 5
19	19600	19600	19600	19600	19600	19600	Locknut, 5/8" - 11
20	18542	18542	18542	18542	18542	17657	Cylinder cup, 4" nom. (MK111: 4-1/2" nom.)
21	18736	18736	18736	18736	18736	18736	Street tee, 3/8"
22	18739	18739	18739	18739	18739	18739	Hydraulic hose, 3/8" x 17" long
23	--	--	--	--	17468	17468	Hydraulic hose, 3/8" x 32" long
24	--	--	--	--	17457	--	Hydraulic hose, 3/8" x 390" long
24A	--	--	--	--	--	17672	Hydraulic hose, 3/8" x 473" long
24B	--	--	--	27480	--	--	Hydraulic hose, 3/8" x 273" long
25	--	--	--	17381	17381	17381	Check valve
26	--	--	--	17382	17382	17382	O-ring, 5/8" OD x 1/2" ID x 1/16" CS
	18033	18034	18035	27535	17466	17650	Cylinder assembly

MK Reverser

MK80, MK100, MK130

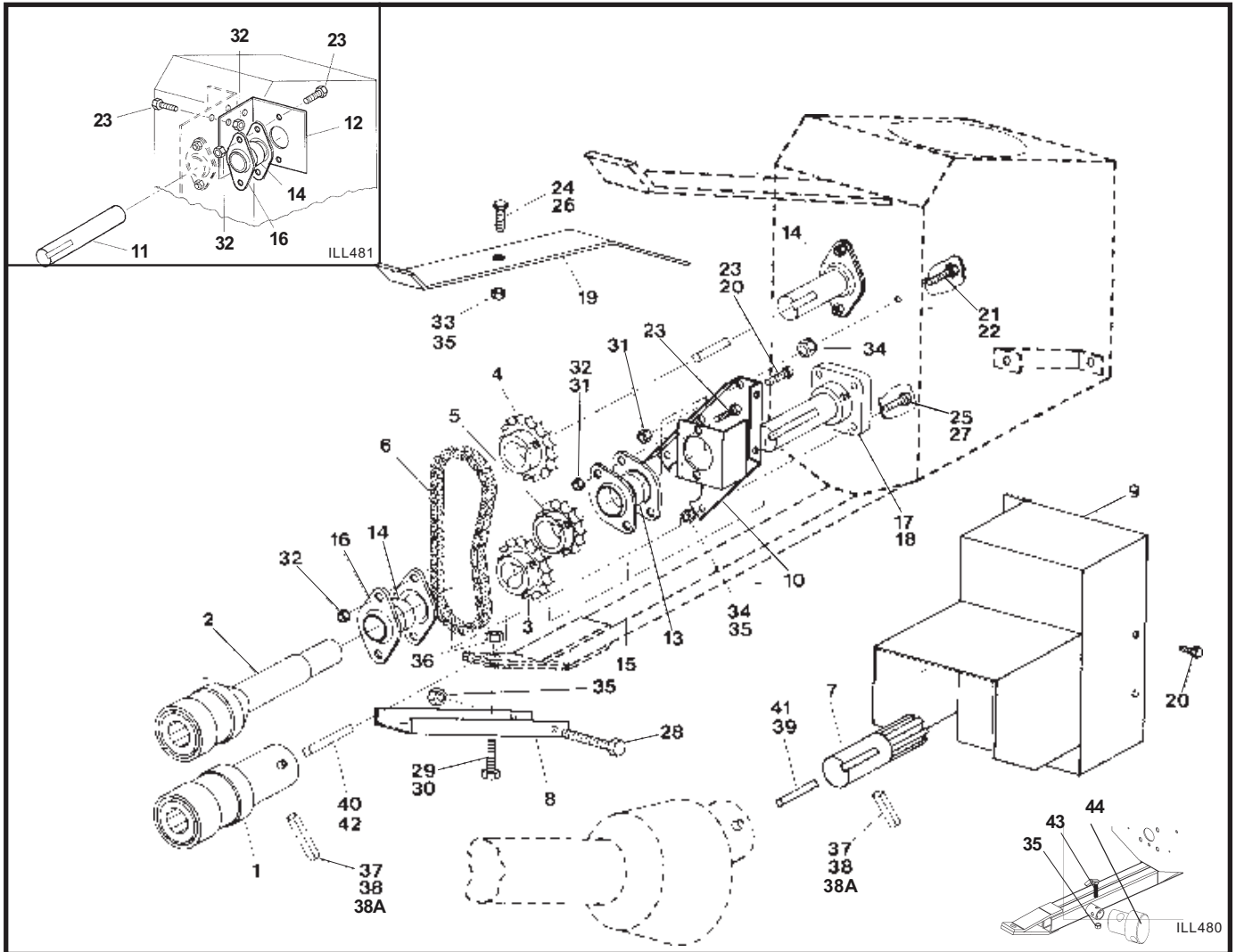

REF. NO.	PART NO.			PARTS DESCRIPTION
	MK80	MK100	MK130	
1	17051	17051	17052	Lower coupler
2	17053	17053	17054	Reverser coupler
3	18710	18713	18525	Lower sprocket
4	18710	18713	19779	Upper sprocket
5	18710	17067	17068	Reverser sprocket
6	18725	18726	19781	Roller chain (MK130 add one 17400 - half link)
7	18176	18176	17023	Spline shaft
8	17055	17055	17056	Hitch extension
9	17057	17057	17058	Shield
10	17059	17059	17060	Bracket (MK130 not as shown)
11	17061	17061	--	Stub shaft (hyd. drive only)
12	17062	17062	--	Bearing bracket (hyd. drive only)
13	18817	18817	18853	Bearing, less flanges
14	18853	18853	18853	Bearing, less flanges
15	18694	18694	18695	Flangette
16	18695	18695	18695	Flangette
17	19567	19567	18518	Bearing assembly
18	18852	18852	--	Bearing insert only
19	17063	17063	17064	Saddle extension
20	19538	19538	--	Bolt, 5/16" - 18 x 3/4", grade 2
21	--	--	18091	Bolt, 5/16" - 18 x 1", grade 2
22	18106	18106	--	Bolt, 5/16" - 18 x 1-1/4", shear grade 2

REF. NO.	PART NO.			PARTS DESCRIPTION
	MK80	MK100	MK130	
23	19540	19540	19540	Bolt, 3/8" - 16 x 3/4", grade 2
24	19542	19542	--	Bolt, 7/16" - 14 x 1", grade 5
25	19589	19589	--	Bolt, 1/2" - 13 x 1-1/2", grade 5
26	--	--	19590	Bolt, 5/8" - 11 x 1-1/2", grade 5
27	--	--	18544	Bolt, 5/8" - 11 x 1-3/4", grade 5
28	18545	18545	18545	Bolt, 5/8" - 11 x 4-1/2", grade 5
29	19592	19592	--	Bolt, 3/4" - 10 x 2", grade 5
30	--	--	19978	Bolt, 3/4" - 10 x 3", grade 5
31	19595	19595	19595	Washer locknut, 5/16" - 18
32	19596	19596	19596	Washer locknut, 3/8" - 16
33	19598	19598	--	Locknut, 7/16" - 14
34	19599	19599	19599	Locknut, 1/2" - 13
35	19600	19600	19600	Locknut, 5/8" - 11
36	19601	19601	19601	Locknut, 3/4" - 10
37	18079	18079	--	Roll pin, 5/16" x 2"
38A	--	28584	--	Roll pin, 5/16" x 2-1/2" (MK81-91 only)
38	--	--	18546	Roll pin, 3/8" x 2-1/2"
39	19606	19606	--	Square key, 1/4" x 1-1/2"
40	19607	19607	--	Square key, 1/4" x 3"
41	--	--	17066	Square key, 3/8" x 1-3/4"
42	--	--	18541	Square key, 3/8" x 3-1/2"
43	--	--	17607	Jack extension bolt, 5/8"
44	--	--	17606	Jack mount extension

A199, A200, A201

MK Right Angle Drive

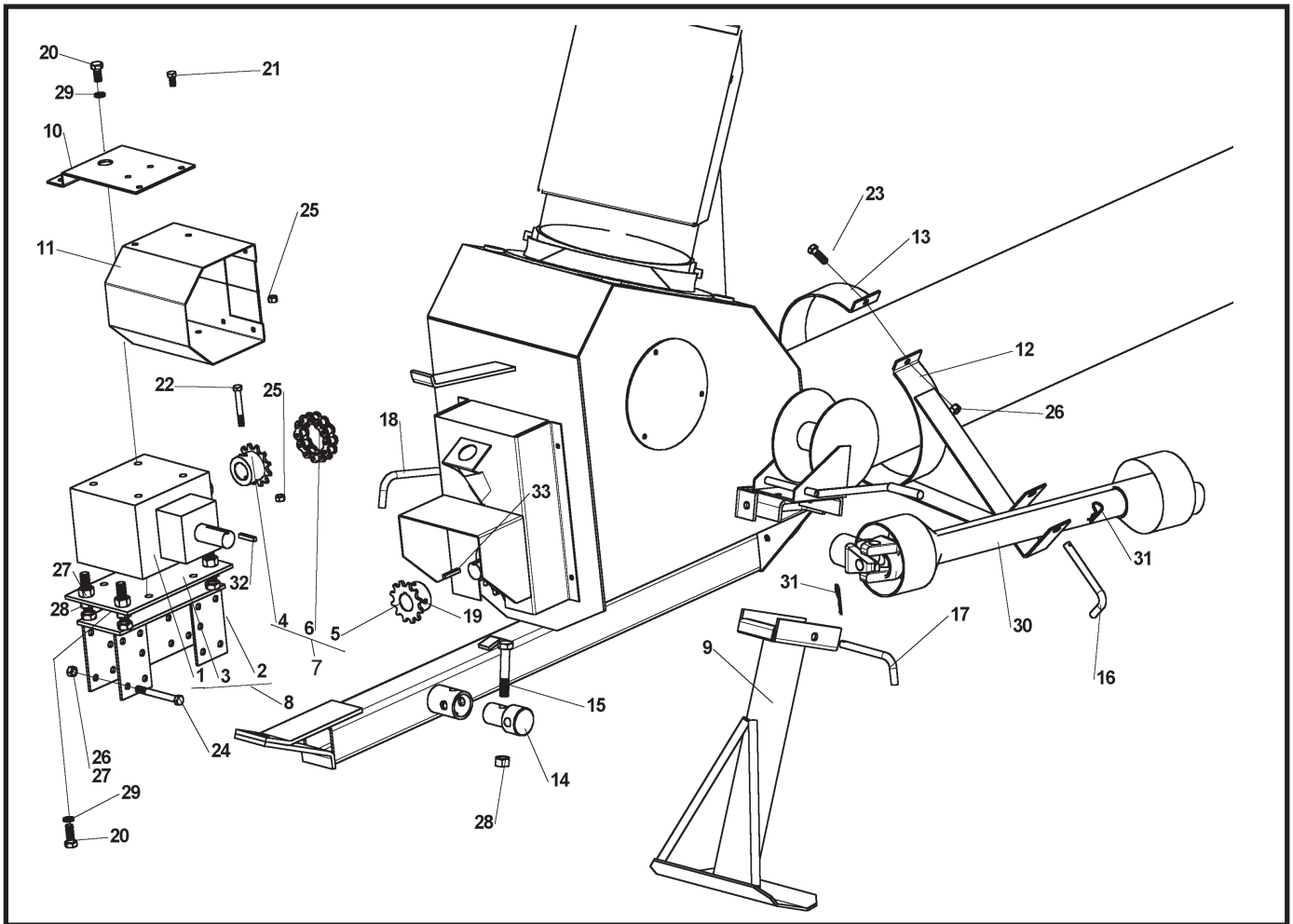

REF NO.	PART NO.			PARTS DESCRIPTION
	MK80	MK100	MK130	
1	19585	19585	17250	Gearbox
2	17594	17594	17601	Gearbox mount weldment
3	17597	17597	17604	Adjust plate
4	17636	17636	--	Coupling spkt, 1-1/4" w/bolt
4	--	--	17608	Coupling spkt, 1-3/4" w/keyway
5	19802	19802	--	Coupling spkt, 1-1/4" w/keyway
5	--	--	17608	Coupling spkt, 1-3/4" w/keyway
6	19559	19559	--	Chain #60 x 12 c/w con. link
6	--	--	17254	Chain #60X16 DS c/w con. link
7	17637	17637	17641	Flex connector
8	17596	17596	17603	Gearbox assembly as shipped
9	17595	17595	17602	Leg
10	17598	17598	17605	PTO shield attach plate
11	17232	17232	17258	PTO shield assembly
12	19461	19804	17259	PTO transport saddle
13	19460	19801	18987	Halfband
14	--	--	28429	Jack mount extension
	--	--	17606	Jack mount extension (Before July 2007)
15	--	--	17607	Jack mount extension bolt
16	19648	19648	19648	Saddle mount pin
17	19648	19648	17181	Leg mount pin
18	18074	18074	18074	Mount pin (leg storage on winch mount)
19	19225	19225	19225	Set-screw 5/16" - 18 x 3/8"

REF NO.	PART NO.			PARTS DESCRIPTION
	MK80	MK100	MK130	
20	19549	19549	--	Bolt, 1/2" - 13 x 1", grade 5 black
	--	--	17261	Bolt, 5/8" - 11 x 1-1/4", grade 5 black
21	19540	19540	19540	Bolt, 3/8" - 16 x 3/4", grade 5
22	17635	17635	--	Bolt, 3/8" - 16 x 2-3/4", grade 8
23	19542	19542	--	Bolt, 7/16" - 14 x 1", grade 5
23	--	--	18698	Bolt, 7/16" - 14 x 1-1/4", grade 5
24	19982	19982	--	Bolt, 7/16" - 14 x 4", grade 5
24	--	--	17632	Bolt, 5/8" - 11 x 5-1/2", grade 5
25	19596	19596	19596	Washer-locknut, 3/8" - 16
26	19598	19598	19598	Locknut, 7/16" - 14
27	--	--	19600	Locknut, 5/8" - 11
28	19864	19864	19864	Hexnut, 5/8" - 11
29	19605	19605	--	Lockwasher, 1/2"
29	--	--	17262	Lockwasher, 5/8"
30	17610	17610	--	PTO driveline, 60"
30	--	--	17260	PTO driveline, 72"
31	19463	19463	19463	Hairpin
32	19606	19606	--	Square key, 1/4" x 1-1/2"
32	--	--	17066	Square key, 3/8" x 1-3/4"
33	19607	19607	--	Square key, 1/4" x 3"
33	--	--	18541	Square key, 3/8" x 3-1/2"